

# **THE POOR MAN'S JAMES BOND**

**Volume 5**

**By Kurt Saxon**



Debunking the Debunkers



FOUR WINDS  
SHOTGUN  
ARMY DETECTIVE  
COURSE  
SUPER JU JITSU  
THE CLARENCE  
CHRONICLES  
M1 GARAND RIFLE  
PRINCIPLES OF  
INTERROGATION  
THE REPEATING  
CROSSBOW  
HIP SHOOTING  
UNSCRUPULOUS  
BOOK DEALERS  
LENZ'S BOMB  
DISPOSAL GUIDE  
WAR TOYS  
THE ROMAN G. I.  
BLOW GUN  
CHEMISTRY  
METAL CASTING  
SILENCERS

"Knock-Out"  
Spots on the  
Human Body

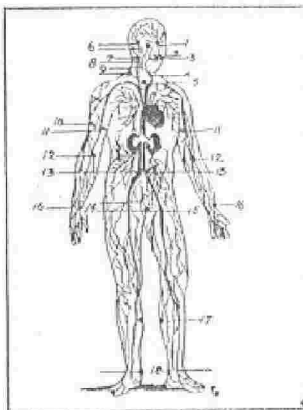

Slide 4

LESSON THREE

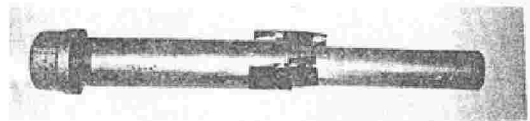

Simplest Pipe Shotgun

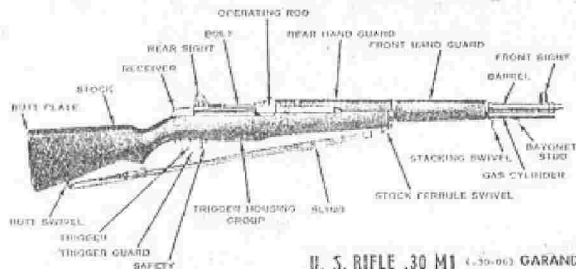

U. S. RIFLE .30 M1 (1-39-00) GARAND



# REPEATING CROSSBOW

By Austin H. Phelps

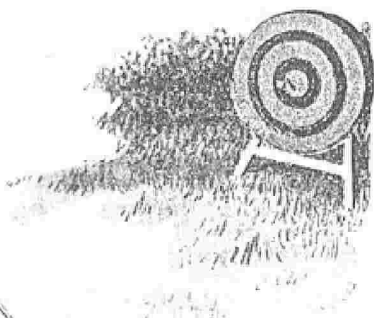

POPULAR MECHANICS  
AUGUST 1951



**T**HIS REPEATING CROSSBOW has all the handling characteristics of a line repeating rifle of the slide-action type. In the hands of an experienced crossbowman it will deliver five shots in five seconds with near-rifle accuracy over ranges up to 40 yards. The steel-pointed arrows, or quarrels, as they are correctly called, are loaded from the top into a magazine just as are the cartridges in a bolt-action rifle. After loading, the bow is cocked by a slide, and the quarrel is fired by pressing a trigger which releases the bowstring. Nocking of the five quarrels in the magazine is done automatically by the repeating mechanism as shown in the lower detail in Fig. 3. The two-piece barrel, Figs. 1 and 2, has a square bore, the groove being cut to full

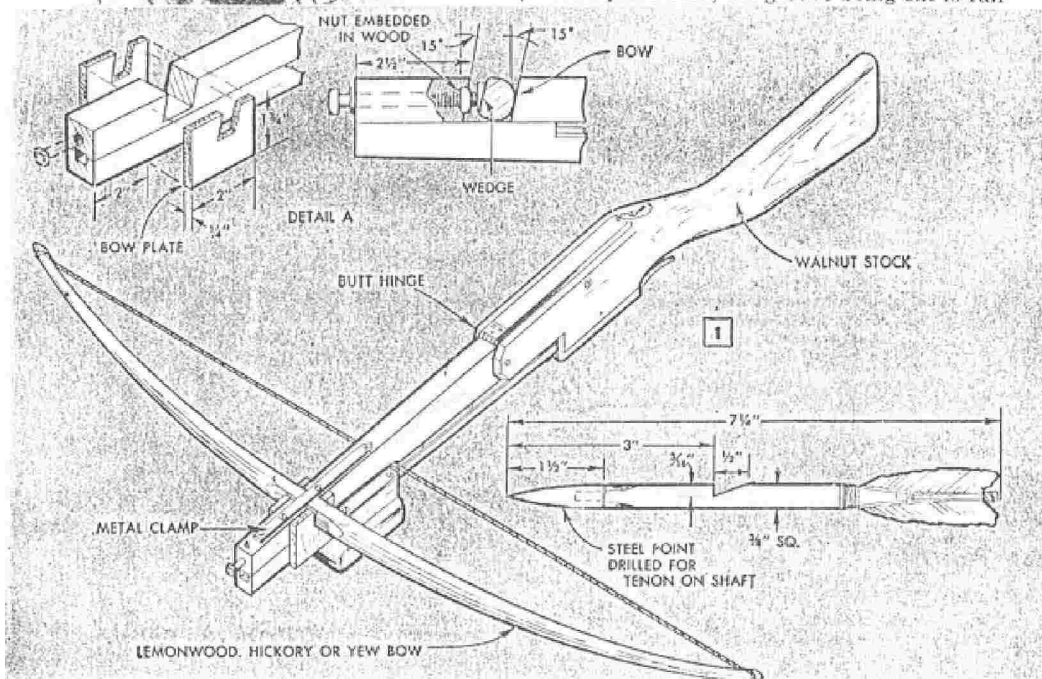

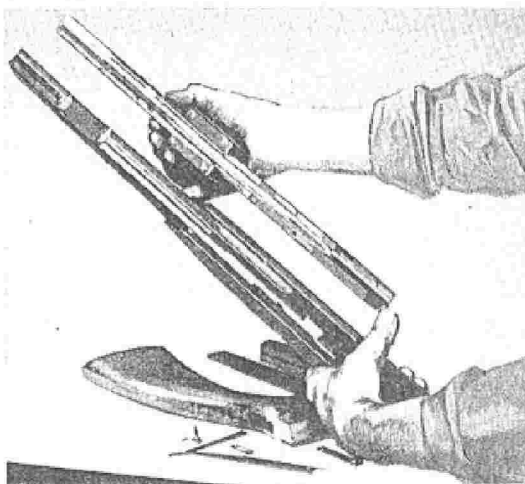

An assembly view of the two-piece barrel showing the pump slide, brass runners, and the top barrel in position. Stock should be handmade to specifications that fit individual user in the same way as a rifle or shotgun stock. Use hardwood for all parts

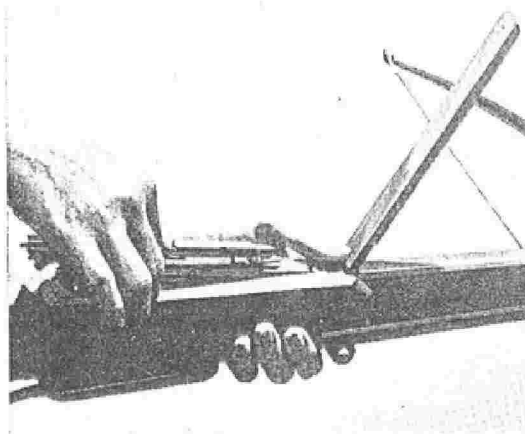

Above, this repeating crossbow is loaded just like a bolt-action rifle, five quarrels being placed in the box magazine at one loading. Below, note the trim lines of the finished job. If desired, you can install either open or peep sights on the barrel

depth in both halves. Then parts of both halves are cut away so that when assembled there will be an offset slot for the bowstring as in the lower detail in Fig. 2. Brass runners, fitted with  $3\frac{1}{2}$ -in. brass strips soldered edgewise to them, are screwed to the lower barrel as in the center left-hand detail in Fig. 2. Care must be taken to space the runner strips so that the inner edges are exactly flush with the inner edges of the magazine liners. After making a trial assembly, it may be necessary to file the slanting ends of the  $3\frac{1}{2}$ -in. strips or the underside of the upper barrel to permit free passage of the bowstring through the offset slot. The purpose of the offset in the slot is to force the bowstring upward sufficiently to release it from the notch in the quarrel, permitting the latter to enter the bore in free flight.

In making the stock, it's a good idea to copy a rifle or shotgun stock that fits you and has a grip and tang shaped to your liking. Bandsaw the wood to the rough outline of the stock selected, then finish to contour with wood rasps and sandpaper. Care must be used in cutting and finishing the magazine slot in the stock, as the magazine liners must be spaced accurately so that the quarrels drop freely into firing position, Fig. 3. The inner rear corners of the liners are rounded to a smooth curve. To assure free movement of the quarrel in firing position, it may also be necessary to round the inner corners of the brass runners. The pump slide, Fig. 2, engages the bowstring as in Fig. 1 when in the forward position. Overhanging brass strips, which are screwed to the guide blocks, Fig. 2, ride on the brass runners. In cocking, the slide is drawn back as far as it will go and the forward end is pulled

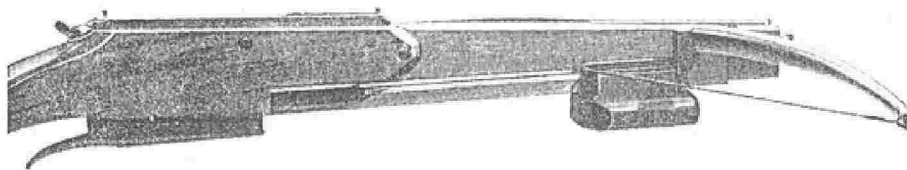

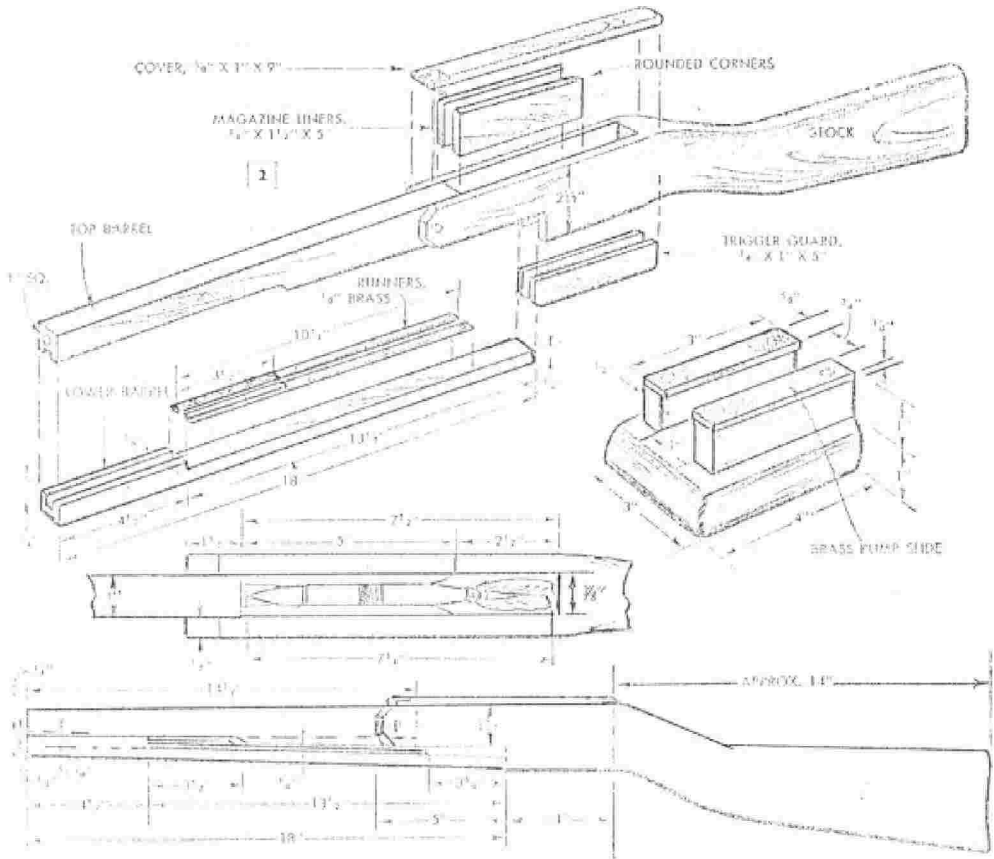

down slightly so that the ends of the brass strips on the slide engage the ends of the runners. This movement locks the slide in firing position and a groove cut across the rear end of the slide engages the trigger sear, as shown by dotted lines in the lower detail, Fig. 3. Simultaneously, the bowstring passes between the first and second quarrels, and the lower quarrel is automatically nocked ready for firing. Provide a hinged cover for the magazine and a trigger guard. Then fit a lemonwood bow of 30 to 50-lbs. pull, using bow plates and a clamp made as in the upper details in Fig. 1. Although the dimensions of the quarrels in Fig. 1 specify that the shaft shall be  $\frac{3}{8}$ -in. square, it is best to finish the shaft slightly under this dimension to allow correct clearance. Practice quarrels should be blunt pointed.

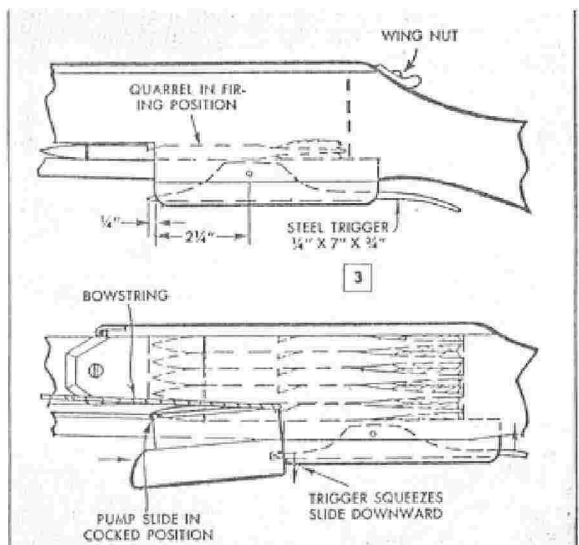

# Notes on Making a Crossbow

THE AMERICAN RIFLEMAN

FEBRUARY, 1933

By EDWARD P. HAMILTON

(LEFT) SHOWING METHOD OF MOUNTING BOW. (RIGHT) END OF BOW, SHOWING SHAPE OF ROCK

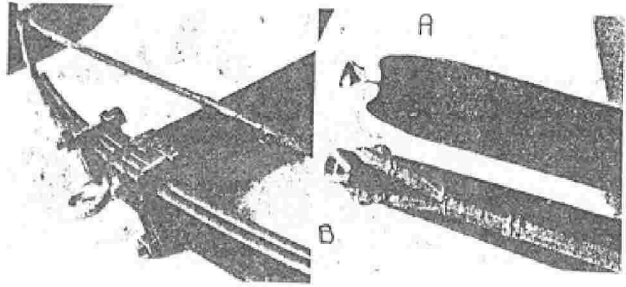

effect this means that in going 100 yards the arrow drops some 14 yards, which is about one seventh of the range. To one thinking in terms of .270 Winchesters and Hornets this is an impossible trajectory, yet we know that a good many deer and other game have been killed in recent years with the longbow. Such a trajectory requires very careful and skillful estimation of the range, and this is one of the fascinating elements of the game, for it really must be considered a game as far as the average man is concerned. Few of us have the time to develop the skill necessary for serious hunting. The crossbow is essentially the same as the longbow, and while its trajectory may be slightly flatter, the question of elevation is just as vital.

Offsetting to some extent the low velocity is the comparatively great weight of the projectile. A crossbow bolt, or arrow, should weigh from 1 to 2½ ounces, depending upon the bow. A weight such as this moving at even 150 feet per second has considerable energy. Blunt-headed arrows have been driven by 75 pound hunting longbows through a 1" pine board. When a broad-headed hunting arrow is used the penetration on animal tissue is very considerable and the wound is certain to cause great loss of blood.

The power of a crossbow is of course determined by the strength of its bow. I have been unable to find any information as to the strength of the old crossbows save in one instance, where a very powerful siege crossbow was found to pull 1,200 pounds. My guess, and it is not a great deal more than a guess, is that the

average old steel-bowed weapon had a pull of from 500 to 900 pounds, depending upon its use. The military bows were the heaviest in order to penetrate armour. Unless one can afford to have a steel bow forged to order, probably almost, such power cannot be readily obtained, and it is best to be content with less.

If it is hoped some day to use the bow for hunting, it should be made as powerful as possible, if only to get a fairly flat trajectory. Old time crossbows were usually adjusted for a point-blank range of from 25 to 50 yards, but even at this range the line of departure of the bolt was at an angle upwards. Since building my crossbow I have twice increased its power, and it could still stand a bit more. The point I am trying to bring home is that if it is going to be any more than a toy your crossbow must be as powerful as possible. This means that very considerable forces will be involved and that everything must be solid and strong. To my mind it is utterly out of the question to consider using an old gunstock; it will be certain to break.

Our first and most serious problem is a satisfactory bow. This could be of wood, but steel is more powerful and much more satisfactory in every way except that of fabrication. For the weapon to be convenient and handy the bow itself cannot be very long, or it would be impractical in the woods. Many old steel-bowed crossbows had bows averaging some 30 inches long. This seemed a

THE crossbow has always fascinated me, but I never got around to making one until last winter. At that time I knew nothing about these weapons, and could find almost no information except a number of excellent photographs of old bows in an arms catalogue. A study of these photographs showed the principle of the slotted nut and gave an approximate idea of the length of bow and the length of draw or pull. With this information and a little knowledge of amateur gunsmithing, I began the crossbow and finally finished it. Some months later Sir Ralph Payne Galloway's admirable book was discovered, and certain refinements were planned for the next model, not yet begun. Any information given in these notes is the result either of my own experiments or of studying Sir Ralph's book. This volume, while of great interest, hardly gives the detailed instructions necessary for one to build a complete bow. For example in the matter of the steel bow itself, Sir Ralph's advice is to send a wooden model to Liege in Belgium and have the bow forged there. Nowhere in the book does he say how powerful a bow should be. I hope that these notes will fill in some of the gaps in the book, and will also give most of the essential instructions for building a crossbow to one who does not have access to this most interesting reference work.

As for tools and equipment, not a great deal is required. A lathe is necessary for turning the nut, and an emery wheel will help in shaping the bow. Beyond this a heavy vise, hacksaw, drills, screwdriver, a wood chisel or two, wood rasp, files and sandpaper are about all that are required. Time of course will be saved if the stock can be roughed out on a bandsaw.

In order to avoid disappointment, anyone planning to build a crossbow should have a clear idea of what performance may be expected from it. Both longbow and crossbow project a relatively heavy missile at a low velocity. The result of course is a very curved trajectory. A heavy longbow with a light flight arrow will, under ideal conditions, give a maximum range of almost 300 yards when elevated at 45 degrees. At 100 yards the initial elevation is about 8 degrees. In

convenient length, and was just the length of the second leaf of a Model T Ford front spring, which was used

for the initial experiment. A new leaf costs very little, and it seemed wiser to use it than an old one, since we wished to bend it in the opposite direction and a secondhand leaf might have developed some weakness. The ends of the leaf were shaped as shown by grinding and filing. A high-speed steel hacksaw blade will cut the leaf however, and save some of the time I wasted in grinding. As I remember, this bow pulled some 150 pounds when drawn 6 inches. This did not give as much power as I wanted, so part of another leaf 16½" long was added to reinforce the first one, bringing the pull up to 215 pounds when drawn 6 inches. Most Ford leaves have a hole in the middle, so it seemed wise to reinforce the center with a 4" strip of ¼" x 1½" steel, held by two yokes. These yokes were also used to fasten the bow to the stock. (Fig. 3.)

The bow still lacked velocity, so the pull was extended to 7 inches by adding an extension to the stock. This brought the pull up to about 280 pounds, which was all that I could manage without resorting to mechanical means for cocking. There is shown a curve of tension versus length of pull for this bow. I have bent the bow as much as 8½" without fracture, but it will be noted that beyond some 7½" the increase in power falls off. This, and the additional chance of straining the steel unduly, point toward a maximum desirable pull of about 7 inches. The old bow makers tended toward 5 to 6 inches, but modern steel springs are probably a little better and a little more evenly tempered than the old ones, so the extra pull is reasonable.

Various materials for the string were experimented with, including one of piano wire, which, while theoretically very strong, snapped on the second shot. With the bow described above, the tension in the string when cocked is about 500 pounds, but it must be considerably more when the ends of the bow are suddenly checked after discharge. You can see that the string must be

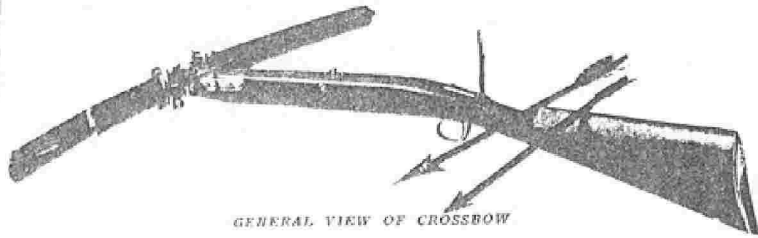

GENERAL VIEW OF CROSSBOW

very stout. The one now in use consists of 44 strands of 18 thread (36 pound test) Ashaway Cuttyhunk fishing line, well waxed and carefully lashed at ends and middle. The photographs will give a good idea as to how the lashings are applied. The string is in one continuous length laid back and forth. All ends are given a couple of half hitches, then a few more turns, and the ends pulled under. The center of the string has two layers of lashing, partly for extra wear and also to bring the string at this point up to ¾", the bolt diameter. My next string will have some seventy strands and only a single lashing at the center, which, however, will have to be watched and replaced at the first signs of wear.

The string should be about ¾" to 1" shorter than the distance between the nocks in order to have initial tension. It could be formed over a couple of pegs the correct distance apart, but I made mine in place on the bow (which was held slightly bent) in order to make sure that the separate strands lay in the nocks evenly; which, however, is probably an unnecessary refinement. If the string is too short, you are out of luck, but if slightly too long a couple of pieces of leather will build up the nocks, as well as furnish a cushion for the string. The leather should be wet thoroughly, and al-

lowed to dry with the string in place. This will mould it to the exact shape of the nocks. My present string has been used considerably but does not yet show any signs of wear.<sup>2</sup>

When strung, the bowstring should be about ½" farther from the center of the bow than was a line between the two

<sup>2</sup> Since writing this, one strand has broken at one of the loops inside the lashing. I shall probably replace this string with one made of heavy linen thread, well waxed, of sufficient turns to give a diameter of just under ¾ inch.

nocks of the bow before stringing. This furnishes a certain amount of necessary initial tension, both in the string and in the bow.

A bow of this strength can be strung and unstrung by removing the short leaf and the yokes, clamping one end in a vise and pulling on the other end. In a heavy bow it is necessary to use what was called a "bastard string." This was a second string temporarily fastened to the bow ends just inside the nocks, by clamps or lashing. When this second string was pulled back to the nut by whatever cocking method was used, the bow was bent sufficiently to allow the regular string to be slipped onto the nocks. The bastard

(LEFT) COCKING LEVER IN POSITION. (RIGHT) BOW COCKED, SHOWING BASE OF BOLT ON STRING

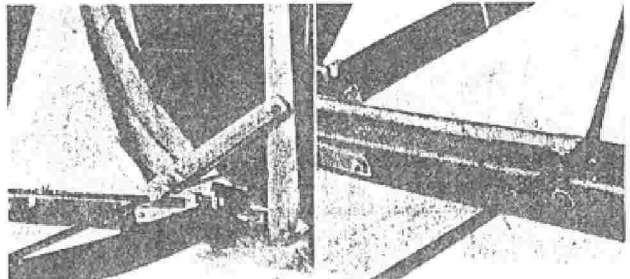

string was then gradually released and removed, leaving the regular string in place. Unlike the longbow, which must be unstrung when not in use, the steel-bowed crossbow may be left strung indefinitely. It can also be kept cocked for hours without loss of power.

The stock must be strong and solid, and it is best made of hard wood. I used a 1 3/4" maple plank, leaving it the full thickness, and about as deep for the whole fore part. Not realizing at the time the fact that initial elevation was required, I gave the stock too much drop. My next bow will have a stock with no drop at all or even a slight negative drop at heel.

The present stock has the following dimensions:

Front of ringbolt to inside of bow	2 1/4 in.
Inside face of bow to nut of lock (including filler block)	9 3/4 "
Nut to trigger	7 "
Trigger to buttplate	13 3/4 "
Overall length of stock	29 3/4 "
Drop at heel	2 "

The front end of the stock should be cut at a slight angle to cant the ends of the bow upward, thus reducing the pressure of the spring down against the stock.

Aslope of 1 to 10 seems about right. The bow must be fastened solidly against the end of the stock. I use two 3/4" x 1/8" string bolts to the yokes and to the stock. Needless to say the bow should be at right angles with the line of the stock, and should lie level when the crossbow is held at the shoulder. The ends of the bow should be equidistant from the center of the stock, or the force on the string will be unbalanced causing irregular flight.

The lock opened up all sorts of interesting possibilities since I had no idea as to how the old locks

were built; moreover, I wanted a short, light trigger pull. The cut shows the design finally arrived at, drawn to scale. The nut, so called, was turned from brass rod, and rotates on a 1/4" machine bolt. It is 1 1/2" in diameter, 5/8" thick, with the groove between the flanges a little less than 3/8" wide to fit the base of the bolt. It would have been wiser to make the two flanges a little thicker, say 3/4", but this would have meant

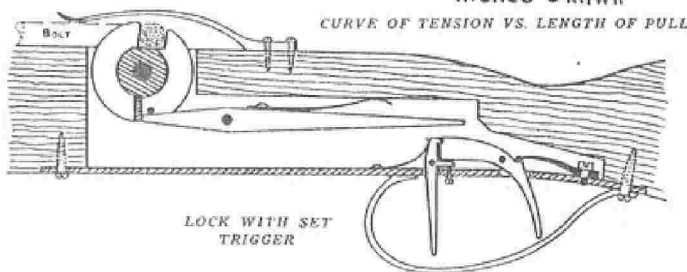
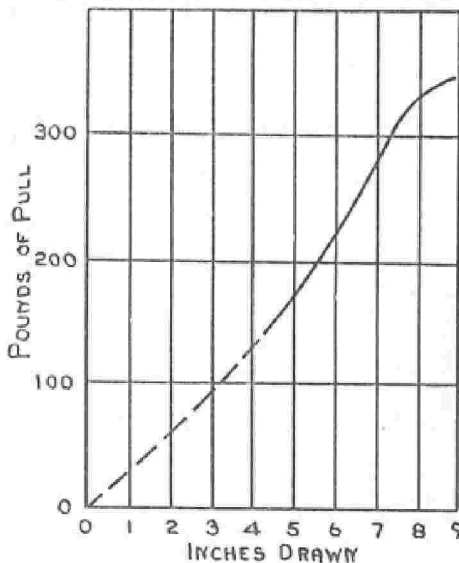

that the wood at the sides of the nut slot would be pretty thin. It would be better another time to use a plank about 2" thick to allow for a wider nut.

The cocking notch is a small plate of steel, set into a slot at an angle as shown, and soldered. The forward end of the sear, where it bears against this plate, is polished. The incline of the plate tends to force the end of the sear out, which, however, is held in place by the second sear. When the second sear is released the main sear drops down allowing the nut to revolve and release the string. The main sear is made of 1/2" square cold-rolled steel, and a small strip of hardened steel is riveted to the rear end for the second sear to bear against. Two little side extensions keep it lined up with the second sear. The second sear is made from 3/8" tool steel, hardened.

The pins should be made of drill-rod, 3/16" for the main sear pin and about 1/8" for the others. The trigger and connecting rod can be anything you wish, as there is not much strength required. This type of lock is quite simple to make, and there are no particular pitfalls. If you get into difficulties, try assembling all the parts on one side of the stock after driving the pins only partly home. This will let you see how the parts work while held in their exact relative positions. This lock holds perfectly a pull of some 300 pounds, and yet is released by a trigger pull of about 6

pounds. At first I had a stop on the nut to prevent its rotating more than was necessary, but the force was such that part of the stock started to split, so the nut was left free to revolve, and rests on the string. A small spring and plunger prevent its falling out when pointed downwards.

The base of the bolt lies between the two flanges of the groove, but a V-shaped piece of steel held by the ringbolt forms a forward rest for the bolt (not shown in the photographs).

The bolts used in the old crossbows were of wood, some 12" long and about  $5/8$ " in diameter. They had a metal head, and feathers or thin wooden vanes at the rear. They probably weighed from 2 to 2½ ounces on the average. The later sporting bows shot a bolt which was really a short arrow. The weight of the bolt must be adjusted to the bow in order to secure best results. This weight must be found by experiment. My bolts are 12" long by  $3/8$ " diameter. I have made them of pine dowel, birch dowel, and brass tubing, and of various weights from 1½ to 3 ounces. At present I am inclined to believe that a 12" birch dowel with two feathers about 3" long by  $1/4$ " wide, and sufficient head to bring the weight to about 1¼ ounces, is the best combination. Bolts made of brass tubing with a short piece of dowel in the rear end to carry the feathers, and weighing some 2 ounces, have greater penetration and apparent energy, but they are driven with less velocity by my bow, and do not have as flat a trajectory as do the lighter ones.

For target work the metal heads of the bolts are slightly rounded, while for small game it is well to have an enlarged tip, such as a  $3/4$ " ball. A large blunt head has the added advantage of quickly arresting the penetration of the bolt in the ground, a great source of lost bolts. It is quite uncanny how a 12" bolt can hide itself completely in the smoothest lawn. Should you decide to try for a deer you must use a hunting

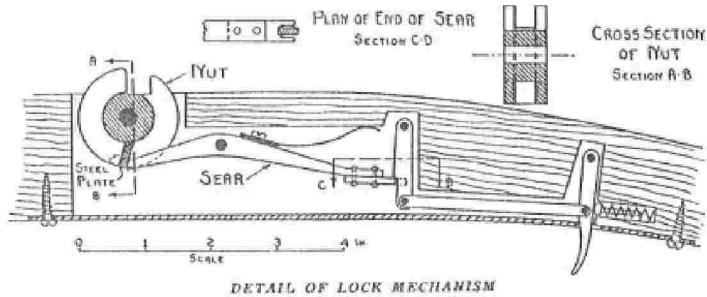

broad-head point, as developed by Dr. Pope. This is a barb-shaped blade cut from 1/32" or 1/16" steel, sharpened on both edges. One such arrow is shown in the cut of the complete crossbow. A short length of  $3/8$ " brass tubing can be flattened and slit for part of its length and the blade fastened in the slit by riveting and soldering, the round part of the tube forming a socket for the shaft. Dr. Pope used blades 3 inches long by 1¼ inches wide at the barb.

The blunt pointed  $3/8$ " 2-ounce arrows will go through a  $5/8$ " pine board, and often through a  $3/4$ " one. At 20 yards the steel broad-head arrows will put the point through a 1" hard pine board. The 1¼-ounce bolts have somewhat less penetration but a flatter trajectory. Shot straight upward it is 10 seconds before my bolts return to earth. Theoretically this means a vertical flight of some 400 feet and a velocity of about 160 f.-s.

Dr. Pope said that a heavy-hunting longbow (65 pounds) gave 150 f.-s. velocity to a light arrow, and could send it into the air for 8 seconds, to a measured height of 350 feet. From this it would look as if my crossbow were about the same in power as a heavy-hunting longbow.

#### FIRE CRACKERS THAT POP TWICE— HOW THEY ARE MADE.

In China there is a fire cracker which pops twice and which is a source of wonderful amusement to the little Chinese boys. It is called the "Twice Sounding" cracker. It has two chambers separated by a plug of clay through which runs a connecting fuse. There is also a fuse extending from the powder in the lower chamber through the side of the cracker. When the cracker is to be fired it is set on end and the fuse is lighted. The powder exploding in the chamber, throws the cracker upward, and while it is yet high

Shooting a 1¼-ounce bolt with a 280 pound, 6¾" pull requires a little over one degree elevation for 25 yards. This means a drop of some 18 inches at this range, and an initial velocity in the neighborhood of 200 f.-s. At 50 yards the elevation is 3¼ degrees, and the time of flight approximately a second. A standard 28" longbow arrow weighing 1½ ounces has been driven 95 yards by my crossbow with an elevation of 11 degrees. The extreme range is probably from 200 to 250 yards, but I cannot say definitely. A range such as this is about all that can be expected from a light to medium weight crossbow.

In some modern crossbows the base of the bolt is struck by the string, but I believe that the bolt should rest snugly against the string before release in order to secure the greatest efficiency. The arrangement of a grooved nut to allow the bolt to rest against the string was used in all the old crossbows, with the exception of some of the later light-target bows.

A crossbow should never be fired without a bolt on the string. It would be very apt to break the bow or the string, or both.

in the air the second charge is exploded by fire from the fuse extending through the plug between the two chambers. In their manufacture the clay is first tamped in with a punch to form the separating plug. The lower chamber is then loaded with powder and closed by turning over the paper at the end. The upper chamber is loaded and closed with clay. A hole is punched in the side of the lower chamber with an awl and the fuse inserted through this opening.



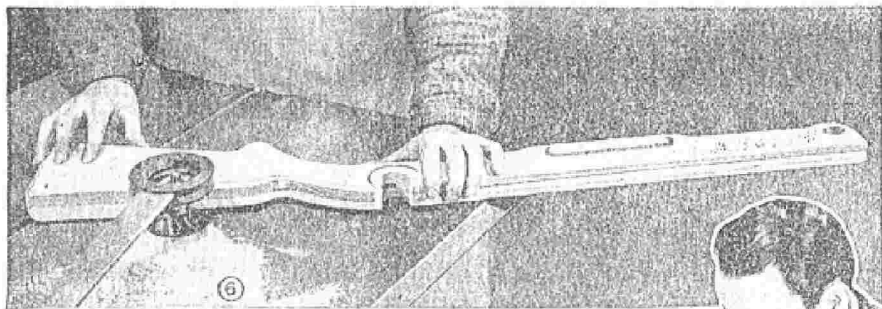

# Modern CROSSBOWS

trigger being cut. Run in the arrow and hand grooves, using suitable shaper cutters. Then, shape all the edges  $\frac{1}{2}$  in. round, stopping about 1 in. from the release hole as indicated in Figs. 6 and 8.

All working parts of the action are made from plastic. Dimensions given will provide sufficient strength for bows up to 60 lbs. drawing weight. Over this weight, the release plates should be  $\frac{3}{16}$ -in. plastic and the trigger should be made from  $\frac{3}{16}$ -in. metal. After fitting the release plates, the top of the stock is sanded down to about the dotted line shown in



*Cocking lever*

is required when bow pulls over 100 pounds. Bows that pull less than this weight can be set by hand

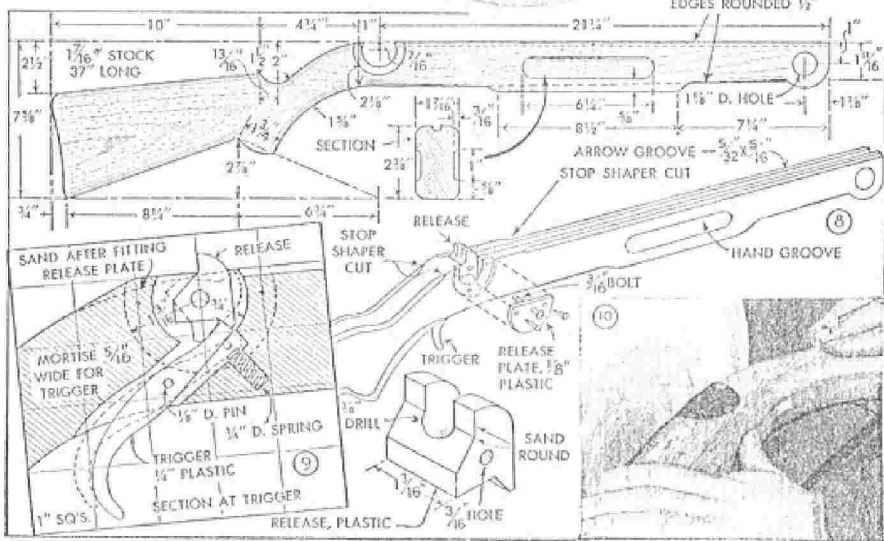



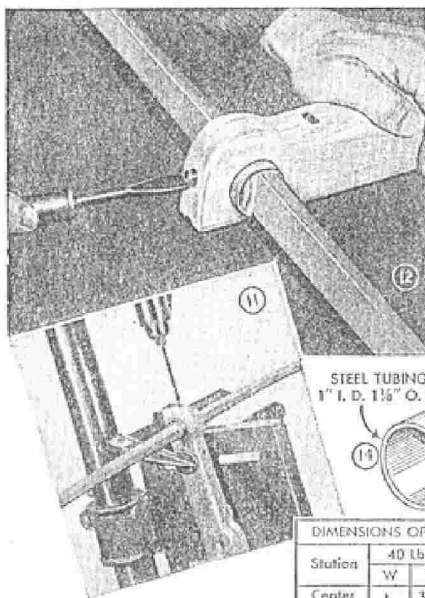
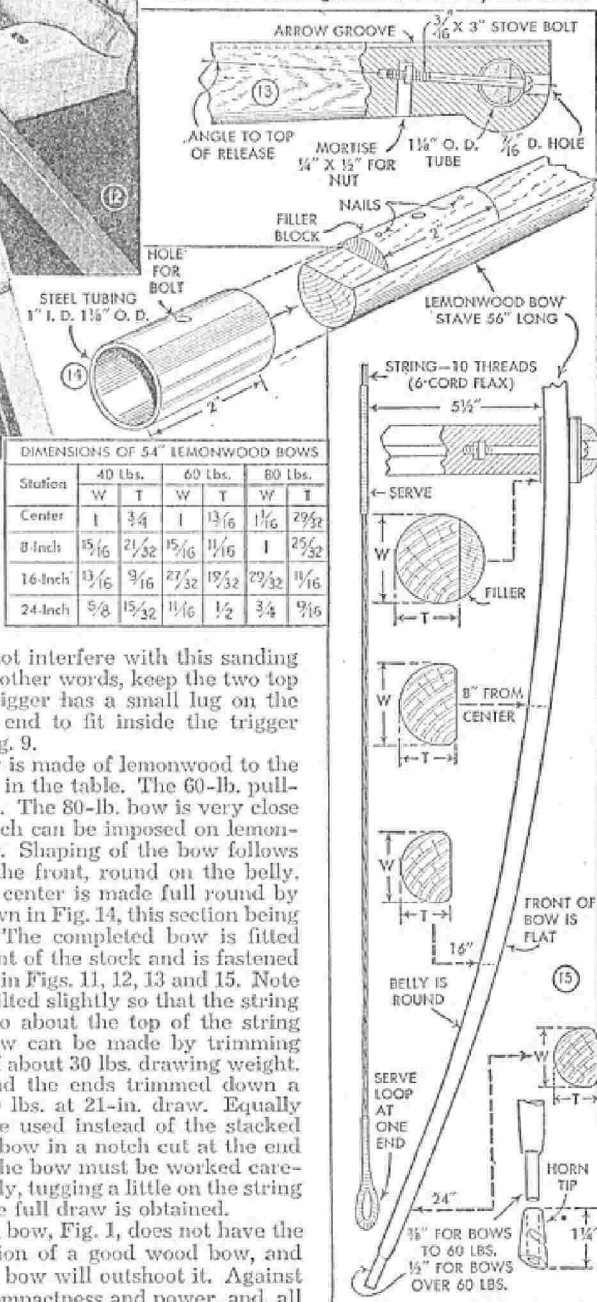

Fig. 9. Fig. 10 shows the operation. The sharp edges are then faired into the shaper cuts. Be careful in fitting the release plates so that screws will not interfere with this sanding and rounding operation, in other words, keep the two top screws low. The plastic trigger has a small lug on the underside near the upper end to fit inside the trigger spring, as can be seen in Fig. 9.

**The wood bow:** The bow is made of lemonwood to the approximate sections given in the table. The 60-lb. pulling weight is recommended. The 80-lb. bow is very close to the maximum stress which can be imposed on lemonwood in this length of bow. Shaping of the bow follows standard practice, flat on the front, round on the belly. A section 2 in. long at the center is made full round by adding a filler block, as shown in Fig. 14, this section being enclosed in a steel tube. The completed bow is fitted through the hole at the front of the stock and is fastened with a 3/16-in. bolt as shown in Figs. 11, 12, 13 and 15. Note in Fig. 13, that the bow is tilted slightly so that the string when pulled back comes to about the top of the string release. If desired, the bow can be made by trimming down a regular 6-ft. bow of about 30 lbs. drawing weight. When this is shortened and the ends trimmed down a little, it will pull about 60 lbs. at 21-in. draw. Equally practical, a flat bow can be used instead of the stacked type shown, mounting the bow in a notch cut at the end of the stock. In any case, the bow must be worked carefully and broken in gradually, tugging a little on the string and then releasing until the full draw is obtained.

**The steel bow:** The steel bow, Fig. 1, does not have the silky, smooth shooting action of a good wood bow, and pound for pound the wood bow will outshoot it. Against this, the steel bow offers compactness and power, and, all

**Wood bow** is 54 inches long, made from lemonwood. Approximate section for 40, 60 and 80-lb. bows are given in table below. Bow is strengthened at center by steel sleeve



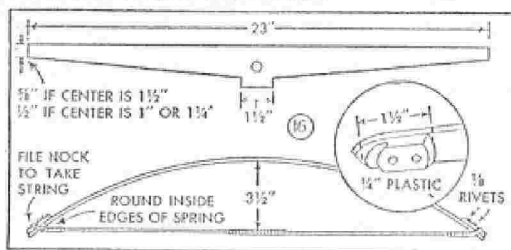

*The steel bow* is compact and powerful. Metal is obtained from a light automobile spring, which is sawed with high-speed steel hacksaw blade to the shape shown above

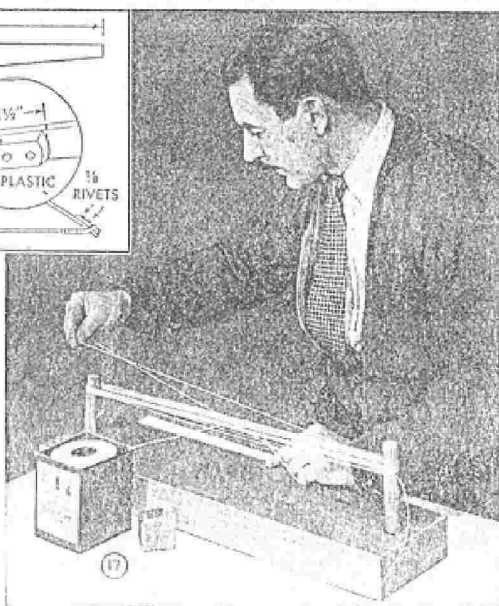
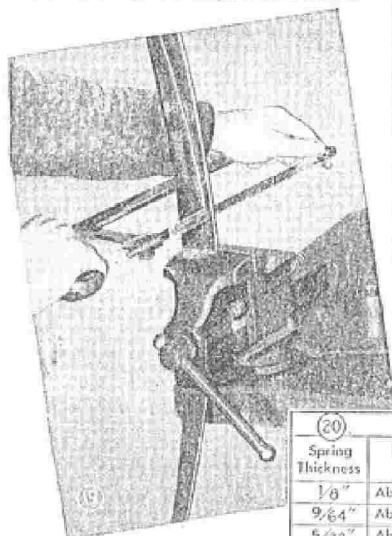

(20) 23-IN. SPRING-STEEL BOWS

Spring Thickness	Initial Set	Brace	Spring to Release	Pull and Threads to Hold		
				1" Wide	1 1/2" Wide	1 1/2" Wide
1/8"	About 2 1/4"	3 1/2"	11 1/2"	42 lbs./12	52 lbs./12	63 lbs./12
9/64"	About 2 1/4"	3 1/2"	11 1/2"	60 lbs./12	75 lbs./16	90 lbs./18
5/32"	About 2 1/4"	3 1/2"	11 1/2"	83 lbs./16	104 lbs./20	126 lbs./24
3/16"	About 2 1/4"	3 1/2"	11 1/2"	142 lbs./28	179 lbs./36	216 lbs./42
7/32"	About 2"	3"	10 1/2"	188 lbs./38	236 lbs./48	285 lbs./56
1/4"	About 2"	3"	10 1/2"	289 lbs./56	363 lbs./70	438 lbs./82

things considered, makes much the better cross-bow. The spring stock can be obtained from a light automobile leaf spring. It will cost you two high-speed steel hacksaw blades to saw it to shape, Fig. 19. If the spring is a little wider than needed, it is a good idea to leave the extra metal intact at the center, as shown in Fig. 16. The bow tips are cut from sheet plastic, riveted in place and filed to take the string. The steel bow will have an initial fixed set of about 2-in. deflection, and should be braced at 3 1/2-in. deflection as shown in Fig. 16. The table, Fig 20, shows approximately what leaf-spring steel will pull in pounds at 11 1/2-in. draw. A 100 to 160-lb. bow is recommended. Extremely heavy bows over 300 lbs. drawing weight make nice exhibition pieces for flight or penetration shooting, but are no fun to shoot as you seldom retrieve the arrow intact if at all. It is prac-

tical, however, to make two or three bows of different weights, all interchangeable on the same stock.

**Bow strings:** Bow strings for wood bows can be purchased or made from 6-cord flax thread. This kind of thread is used in stitching machines by shoemakers. Twelve threads will hold wood bows to 80 lbs., the loop at the end being made by turning the whole string back on itself. The string for a 23-in. steel bow is made on a simple wooden form, as shown in Figs. 17 and 18. In this case, the string is divided into equal parts to make the loops. Both loops and a distance of 4 in. at center are wrapped, and the completed string is waxed with beeswax. The string can be shortened by giving it several twists before fitting to the bow. The triangular-boxed figures in table



# Electrical Trimmer Shapes Arrow Feathers

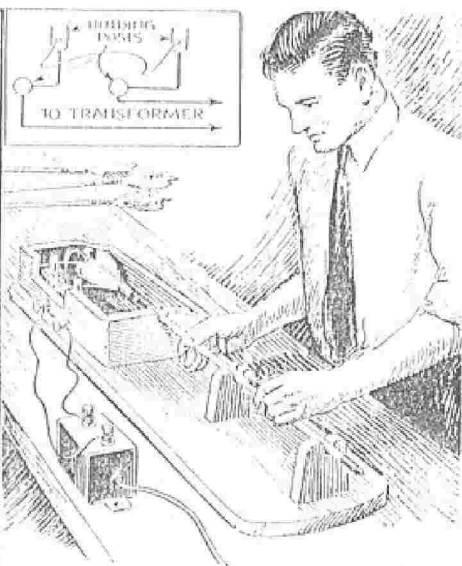
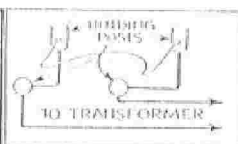
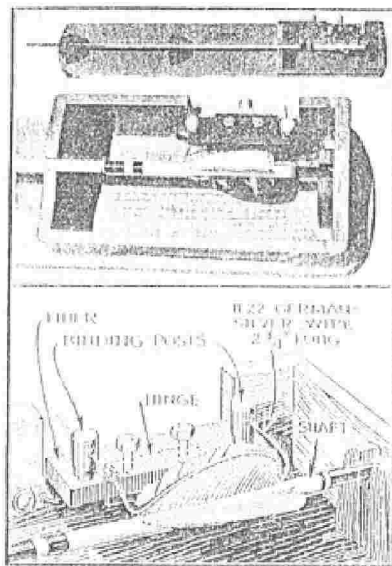

Popular Mechanics June 1938

An important point in producing good arrows is accurate trimming of the feathers, which is often neglected because lack of experience or proper tools makes the job difficult. The electric trimmer shown above enables anyone to do the job in a professional manner. The trimmer consists of a hardwood base carrying notched supports in which the arrow is laid so that the feathered end can be rotated against a hot resistance wire shaped to the correct contour. The base is 5 by 21 in., and the inside dimensions of the bedlike end are 3½ by 7 by 2 in. This allows the full, uncut feathers room to turn and fall, and also allows cradling the entire pointed part of the arrow without fear of snagging. The notches in the box ends and in the support pieces are ⅜ in. deep with the back sides cut straight. This permits one side of the arrow, regardless of its diameter, to be a constant distance from the trimming wire. At the back of the box, a 2½ by 3-in. section is cut out and a piece of fiber the same size is substituted. This is hinged at the bottom so that it may be dropped to a horizontal position or left straight up out of the way when not in use. Binding posts

in this piece hold the resistance wire and are connected to posts at the rear of the box. Clearance between the shaft and the closest points of the wire should be about ½ in. Operating temperature of the wire must not be too hot or too cold. Using a 6-volt transformer, a No. 22 German silver wire between 2½ and 3 in. long will give excellent results. The wire must be almost white hot, otherwise the feathers will merely melt and gum the wire.

## Tin Cans Threaded on Taut Wire Serve as Rifle Targets

Inexpensive rifle targets can be provided by simply stringing a number of tin cans

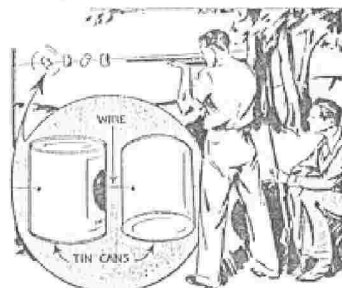

on a wire stretched tautly between a couple of posts or trees. If the cans are attached so that they are balanced, they will spin when hit from a suitable distance.

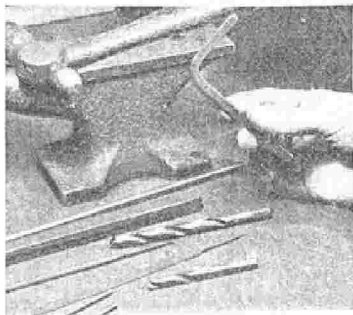

Old files, drills, wrenches can be transformed into good gun tools. For a bottoming tool, select an L-shape wrench for hollow-head bolts

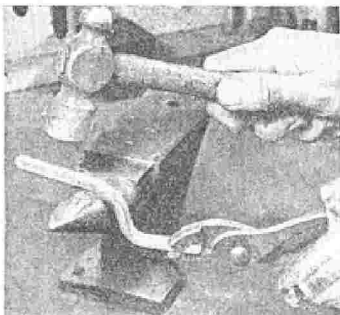

In making the bottoming tool—used to smooth the bottom of the gouged-out slot in a rifle stock—first heat the longer leg and bend it

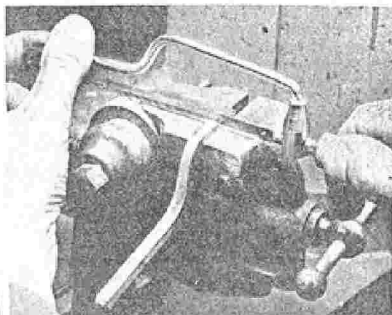

Now start to form the teeth by making a row of shallow saw slots, about  $\frac{1}{8}$  in. apart, on the surface of the short leg of the tool

OUTDOOR LIFE  
SEPTEMBER, 1943

## YOU CAN MAKE FINE GUN TOOLS

THE quiet, lanky craftsman who does restocking work for a large Midwestern arms dealer was showing me his shop. The part of it that caught my eyes was his work bench, and the battalion of odd-looking hand tools that marched, single file, along the back of the work area.

"Quite a collection of tools you have there," I remarked.

"Yes," he agreed. "Just about every kind of chisel, gouge, and checkering tool I need—until the next tricky job pops up."

"Must have cost you a lot of dough."

"Oh, not much. These things are made from scrap stuff, chiefly old files."

"You mean all of them?" There must have been a hundred tools in all.

"Mostly. That's usually the only way to get a special tool when you need it. There's nothing difficult about making such things. Take this checkering tool, for example. I made it from a worn-out triangular file in about 30 minutes, stuck it into a file handle, and have been using it for three or four years. Most gunsmiths and restockers make many of their own tools."

I examined the collection more closely, and marveled at the workmanship. Each of the tools looked as if it had come from a factory—was, in fact, even more carefully made and finished than many a factory-made tool I have seen.

The restocking artist, further conversation revealed, is convinced that any craftsman who is capable of heating steel to redness, and who can wield a hammer and file with reasonable skill, can make his own special tools for tinkering with guns. It's a fascinating hobby in itself, and excellent relaxation from more serious duties, this tool making; and with present-day war restrictions and scarcities, it often is the only way to acquire a much-needed piece of equipment. A few ounces of scrap steel will provide a gun tinkerer with a good

assortment of tools for working on both wood and metal. In many cases, by making his own tools from scrap, the craftsman can release manufactured items for more important duties.

There is virtually no limit to the types of small hand tools that can be fashioned from scrap steel with little more than a hammer, an anvil, and one or two files. A power or hand-driven grinding wheel is handy, but not essential. Some means of heating steel to redness is necessary. A blowtorch, a gas burner, or even a bed of coals in a wood or coal stove will do.

The kind of steel used is tool steel, which means that it contains enough carbon to cause it to harden when heated to redness and plunged into oil or water. The wise craftsman never throws away a worn-out file, for the high-carbon steel from which the file is made can be reworked into some useful tool. Old twist drills and auger bits are almost as useful, though not usually so plentiful in the shop as files. Other scrap sources of tool steel include plane bits, broken chisels, wrenches, screw drivers, heavy springs (such as those used on automobile starters), and random lengths of drill rod. Bolts, nails, and other articles made from cold-rolled or similar steel cannot be used for edged tools because they will not harden when heated and quenched.

SUPPOSE you are hollowing out a stock blank so it will accommodate the action of a rifle. With chisels and gouges you've excavated a rather deep hole in the blank, and are trying to smooth the bottom reasonably well. You find this difficult to do with ordinary tools; but if you have a bottoming tool the job becomes a cinch. The process of making such a tool is similar to that followed in making practically all the other tools you will need.

First, dig around in your junk box

until you find a suitable piece of steel. The tool shown in the photos was made from an L-shape wrench of square cross section, which originally was intended for use with hollow-head bolts. It measures  $\frac{1}{4}$  inch on a side. A square file or rasp of similar dimensions, or a round file of slightly greater diameter, could have been used equally well.

WHEN you find a piece of steel that looks O.K., test it to see if it will harden. Experienced handlers of steels can do this by touching the piece against an abrasive wheel traveling at normal speed. A generous shower of brilliant, much-branched sparks indicates a high-carbon steel. A better way for the tyro is to use a file. If the piece is already hardened, the file will slide over the metal without "biting." If the file does cut into the steel readily, heat the piece until it is a moderately bright cherry red, then plunge it quickly into water or oil (about three parts linseed oil to one part automobile engine oil). Try the file again. If the steel is still easily filed, it is not suitable for tool making. If the file doesn't bite into the steel, the piece is O.K. Of course, if you are going to use an old file, you won't have to make a test, for all file steels are capable of being hardened and tempered.

If you start with a file, or have hardened a piece of steel to test it, you have to anneal (soften) it before attempting to cut, file, or otherwise work it. To do this, heat the piece to a uniformly dull red, then let it cool slowly. If you use a coal or wood fire, bury the piece in ashes while it cools. After this treatment, you can saw, file, turn, or drill the steel easily.

The L-shape wrench had to be bent to the shape indicated, and the end of the shorter portion of the L cut off. A small backsaw did the cutting; a cold chisel could have been used instead. To

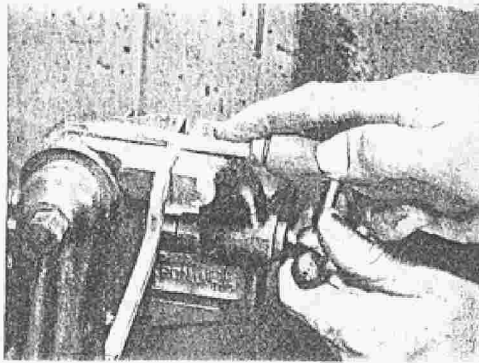

Shape the teeth with a triangular file, giving the front surface of each tooth a backward rake. [See sketch 5-B, on next page.]



After filing, teeth are evened by rubbing on an oilstone. A final bit of filing may be in order, to sharpen teeth that were too long



To harden the finished tool, heat to redness and dip it in oil or brine; then temper it by reheating and quench in water, as above

## From JUNK

By

WALTER E. BURTON

make the bend in the longer section, the steel was heated to redness, and the bending was done with a hammer and anvil, as shown. Instead of a regulation anvil, an old flatiron, section of a car rail, or any similar chunk of iron may be used.

Next the teeth were cut. First, a row of shallow saw slots, spaced about  $\frac{1}{8}$  inch apart, was made on the surface of the leg that was to become the head of the bottoming tool. Then, with a triangular file, the teeth were formed. As seen from the side, these teeth resemble those on a saw. A slightly backward rake of the front surface of each tooth produces a somewhat smoother cutting action because it prevents the tooth from digging into the wood excessively. (See sketch on next page, Nos. 1 and 2, for variations.)

You may fit the handle after the teeth are formed, or wait until the cutting end of the tool has been hardened and tempered. The handle illustrated was one intended originally for use on a file; you used to be able to buy them at any dime store, but the war apparently has strangled the supply. Making such a handle is easy, even without a wood

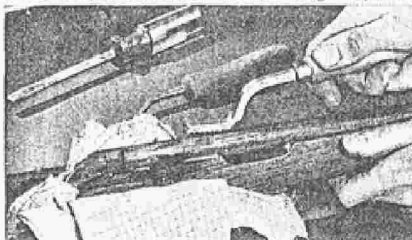

The bottoming tool, equipped with a wood handle, in use. Such tools may be shaped to suit, depending upon the job at hand

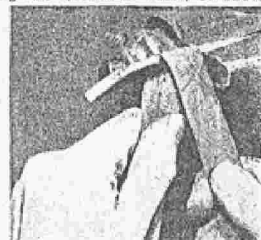

For polishing, use abrasive cloth. This tool, for laying out checkering grooves, was made from a worn-out triangular file

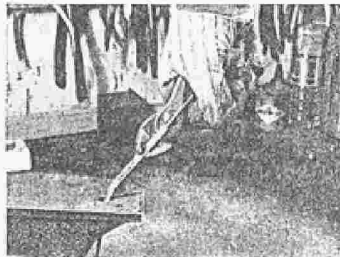

To make a checkering tool, either for lay-out or for smoothing grooves, first heat a file or drill rod and bend it near the tip

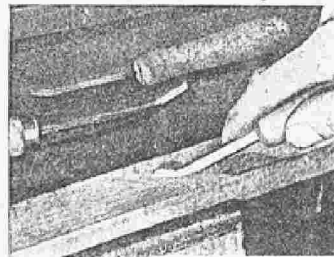

Use scrap walnut to test out your newly made checkering tools—and to develop skill—before tooling a blank stock

lathe. A piece of broomstick makes an excellent handle when properly shaped. A wood rasp, sharp knife, sandpaper, and perhaps some scrapers (made by cutting scrap window glass into 2-inch squares) are used in shaping handles. A ferrule around the tool end of the handle will discourage splitting. It may be made from a short length of pipe or tubing, or can be several turns of moderately heavy wire, the ends of which are secured in some convenient way.

**B**ORE a hole slightly smaller than the shank of the tool, and drive the handle into position while the tool is held in a vise. In the case of tools that are straight or nearly so, all you have to do is to rest the ends on a block of

wood while you drive the handle home.

To harden the cutting end of a bottoming or other tool, heat it until it becomes a uniform cherry red. Plunge it into an oil bath or into strong salt water. Many toolmakers prefer oil for hardening because it is less likely to cause cracking of the steel. The mixture of linseed and engine oil already mentioned is suitable for practically all carbon steels you will encounter. After immersing the steel, keep it moving for several seconds, to insure uniform cooling. Use at least a quart of oil or water.

After the steel has cooled, polish a portion of the hardened area until it shows a bright surface. Then heat the steel again, but very slowly this time. Soon you will observe a change on the



polished surface. It will show a light yellowish tinge. This changes rather quickly to bronze, and then, if you continue heating, will exhibit in succession a considerable range of colors, including brown, light blue, and dark blue. For most woodworking tools, the place to stop is at the reddish-brown point. This is just beyond the dark-yellow or straw-colored period in the steel's color-changing cycle. When the polished surface becomes a reddish brown—usually displaying a spotted effect—plunge the tool quickly into cold water. Polish the discolored areas of the tool with fine abrasive cloth or paper, and it is ready to use.

**REMEMBER**, in tempering tools, that the more you heat the steel after hardening, the softer it becomes. If you want considerable hardness, heat the tool in tempering until a light yellow color appears, then quench in water. Tools such as screwdrivers, in which too much hardness and consequent brittleness is undesirable, should be heated until a rather dark purple color appears.

That, in general, is the way to make a useful tool from a piece of scrap. Here are some other tools that the gun tinkerer will find useful:

**Carving chisels and gouges, and wood chisels of various shapes and sizes:**

Old files and drill bits provide excellent material. It is easy to twist a twist drill after heating it to redness. Clamp its flutes in a vise and grasp the point with pliers or a wrench. Straighten the flutes with a twisting motion.

Cutting ends are usually formed roughly by forging. Heat the metal to a fairly bright red, then shape it by hammering. Be sure to hammer in more than one direction. That is, as you thin down the end of a piece of steel into the semblance of a blade, turn the piece on edge and hammer the edges too. This compacts the metal uniformly. Do not hammer steel too long after the redness disappears with cooling, or you may cause cracking. Finish shaping the cutting end by filing or grinding, or both. Likewise shape the shank,

and other parts of a tool. Finally, polish out at least the more unsightly tool marks with abrasive cloth or paper.

Many carving tools for wood have curved cutting edges. That is, the edge of the tool, when pressed against a surface, makes an arc, a "U," or some similar form. Tools that have V-shape cutting edges are useful too. To form such shapes, first bend the metal while forge-

teeth somewhat like those on a saw, and in cross section (sketch 4-A) has a V-shape bottom whose angle is approximately 60 degrees. The second tool is similar, but has two (sometimes more) rows of teeth. The angle between the rows, likewise 60 degrees, is sharp (4-B).

For English-type checkering, in which the diamonds have flat tops, the cross-sectional shape is as shown in 4-C.

To make either of these tools, start with an old triangular, round, or square file, or a piece of drill rod. Grind or file a flat surface where the teeth go, and shape the head as shown. At a point just behind the head, make a bend so the handle can be held at a comfortable angle while the head is being pushed over the wood. Form the 60 degree angle or angles by filing, and finally cut the teeth by making notches or grooves as shown in sketch 5. The teeth are spaced about 1/16 inch apart. Usually by giving the fronts of the teeth a slight backward rake (as shown in 5-B), a smoother cutting action is obtained. If filed as in 5-C, there is a tendency for them to dig into the wood. Also, by shortening the first tooth or two, as in 5-D, a smoother cut is produced. The exact length and shape of the head of such checkering tools may fit your personal tastes.

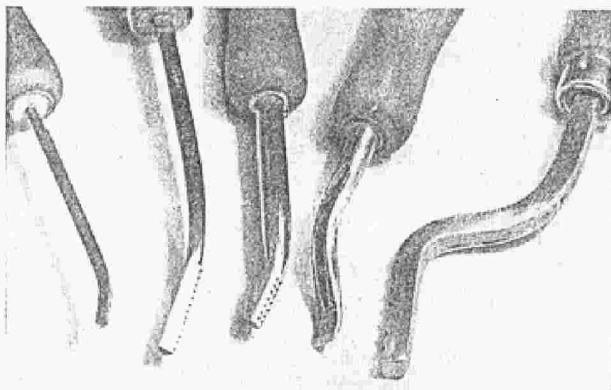

Business ends of homemade gun tools. Left to right: bent-file smoothing tool for checkering, checkering layout tool, two-row checkering tool, carving gouge, and bolt-taming tool

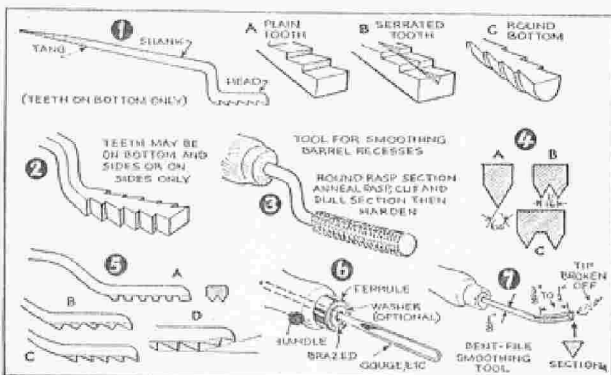

1 and 2. Bolt-taming tool, with four varieties of teeth. 3. For smoothing barrel recesses. 4. Cross sections of checkering layout tools. 5. Checkering layout tools, side view. (C—how not to sharpen teeth!) 6. Detail of carving-tool assembly. 7. Smoothing tool

ing, by testing it on a curved support. Then work out the final shape by filing and perhaps grinding.

**Checkering tools:** Checkering, usually in the form of a collection of small, raised diamonds covering the surface of the pistol grip and fore-end of a stock, has two purposes. One is to provide a nonslipping surface. The other is to improve the appearance of the stock. For the checkering the average craftsman will do, three tools are adequate. One of these, used for making the starting or layout lines of a design, has a single row of

**THE** third checkering tool (sketch 7) is made simply by heating a triangular file and bending the tip slightly so that one of the edges becomes convex. This permits the file to be run along the grooves made by the other checkering tools, to smooth them. Use a file measuring about 3/8 inch on a face. After bending, reheat it and harden in oil or water. If the bend is made about 3/8 inch from the tip and 3/8 inch is broken off, the shape will be about right. If you can obtain no file suitable for making such a smoothing tool, try working down an old one and cutting new teeth with a sharp chisel; it may prove to be easier than you think!

Other tools will occur to you as the need for them

arises. For instance, you may need a special screw driver for working on a gun action. Try forging one from an old file. After hardening, heat it to a dark purple color to temper the steel. Sometimes an annealed file is about right for use as a screw driver without hardening or tempering. A screw driver that is too hard may damage the heads of screws.

A useful tool for smoothing barrel recesses is shown in sketch 3.

Still another tool that you may need is one for checkering metal butt plates,

or plates made of plastic or other material. Usually such a tool takes the shape of a long file with two rows of teeth; it is, in fact, an elongated edition of the second type of checkering tool already described. For cutting the starting grooves, a triangular file may be used.

Carving tools and other "push type" implements, such as a slender veining tool you might make from an old straight-flute drill bit, are somewhat more rigid in their handles if a washer or other disk of metal is attached to

their shanks, as in sketch 6. The best way to attach such a disk is by brazing or hard soldering, and its position is such that, when the tool is in place in the handle, the handle end rests against the disk.

You may have trouble deciding whether it is more fun to make your own gunsmithing tools or to work with them. Anyway, the process often is, these days, the only way to obtain a much-needed chisel, gouge, or checkering implement.

## NEGRO INSURRECTIONS

*Harper's Weekly, Jan. 10, 1857*

The following account of the negro insurrections at Dover, in a Kentucky paper:

"Tuesday morning I went to Dover, and arrived there about two o'clock. The people had hung four negroes at 11 o'clock that morning, and two more were then in town to be hung. I got to the place of execution in time to see the last one go off. Of the six that were hung, three were preachers. They were all proved to be ringleaders. I learned that the men at the forge were at work whipping the truth out of their negroes, so I rode out there that night, and was up with them all night. I never had such feelings in my life. I saw a list of negroes that had been whipped, and was told what they all had stated, and then I heard the balance examined - some taking five and six hundred lashes before they would tell the tale; and when they did tell it, it was the same that all the others had told. Some told the whole story without taking a lick. Those that were examined were not permitted to see those that were not; they were kept entirely separate, and a guard over each. One of the negroes at the forge died from whipping that night, several hours after the operation.

"The substance of their testimony was, that Christmas-eve night they were all to rise. Old Hal, Amos, Anderson, Grey, and Ishmael were to murder Parish, the manager, and his family, except his wife, and she in future was to be the wife of Ishmael. They were to kill young Pepper next (brother of Judge Pepper), and other whites that might be about the place. They were then to meet the Mill negroes at the forks of the road, at Pidgit's, near Long Creek, and were to make a joint charge upon Dover; after they had cleaned up Dover, and provided themselves with arms and ammunition, they were to scatter out over the country generally. At the mill, the negroes, or, rather, Bob Murrill, was to kill George Lewis first, then Henry Erwin, and then the balance indiscriminately. Lewis and Erwin whipped Bob Murrill to death.

"At the old Dover furnace, Charles Napier was to kill brother George first, Mat Hutson was to kill young Tom Buckingham next; and Bill Blair was to kill Edwin, George's son, and Henry and Willie Wynus, and then go to the mill. Brother George hung Charlie Napier one day about 11 o'clock, and let him hang till next day about 1 o'clock - 26 hours.

"I have no doubt but that it is a universal thing all over the Southern States, and that every negro, fifteen years old, either knows of it or is into it; and the most confidential house servants are the ones that are to be the most active in the destruction of their own families. The negroes, every where they are examined, all agree that the men, women, and children are to be slain, and that the young women are to be kept as wives for themselves, and a good many of them about Dover and the furnaces went so far as to select their

future companions."

## HORRIBLE MURDERS

The examination of the negroes charged with the murder of the Joyce family, has taken place at Louisville, Ky. Bill (one of the murderers), made a confession that he and Samuels' George and Jack met, each provided with a club, and went to Joyce's house late on Thursday night; that Jack opened the house, and George said he wanted to get two licks at him (Joyce's brother); that George struck Joyce twice and Mrs. Joyce once with a club; that Jack struck Mrs. Welch with a club; that they then ransacked the house, and set it on fire under the bed, and scattered the fire in the bureau drawers. Mrs. Joyce and Mrs. Welch, who had been only stunned by the blows they had received, had crept out of the bed and were sitting before the fire-place, praying and moaning. The child, who was in bed with young Joyce, awoke when the fire commenced, and seeing it said, "Jack, oh! what a pretty night." The negroes then left, but after having proceeded a short distance, George said it would not do to leave the women alive, as they might tell on them, and they then returned, and Jack struck Mrs. Welch with a meat hatchet, and killed her, and then tossed Mrs. Joyce in the fire-place. The child was left in the bed and burned alive. The hatchet belonged to Jack's master, and it was found there with blood and a particle of brain on it. Jack made a confession that neither he nor his brother George had any participation in the matter, but from what he had heard from one of the Bills, they had committed the deed.

At the examination before the Justice, Mr. Joyce was called to the stand and answered a question. As he stepped from the stand he said, very loudly, "I want all who are my friends to come on and take these negroes and burn them." Almost instantaneously every man in the room was on his feet; from the passage between the benches on the east side the sounds of "Burn them" resounded, and some of those occupying the front tier of benches tried to jump over the railing to get hold of the negroes. Joyce attempted to rush toward the negroes, but was repulsed by Captain Rosseau. The hammer of the Court could not be heard and the voices of the sheriff and his deputies were drowned. The excitement was intense for a minute or two, and every one present participated in it. It was soon made evident, however, that the law-abiding citizens were far in the preponderance, and the tumult was quelled. The accused were committed for trial.

## CONVICTION OF HUNTINGTON AND TUCKERMAN

These two culprits have been disposed of. In the case of the latter, Mr. Choate has filed a bill of exceptions; but the former has been sentenced to four years and ten months' imprisonment, the utmost the law would allow. When he was informed that the



deputy-sheriff was waiting to take him to Sing Sing, he heard the announcement with an air of indifference, and continued smoking his cigar. In a few minutes he came down and stepped into the warden's room, where he had a conversation with three or four of his friends. As he passed the grated door leading into the outer passage he shook hands with three or four of the keepers, with whom he had become acquainted, and having bid them a "good-by, boys!" as his farewell, he went into the street. He displayed great unconcern on leaving, and also on his arrival at the prison. On the day after he arrived an officer rapped at his door and signified that his presence was desired in the physician's apartment, where he was provided with the usual striped wardrobe. He was then conducted to the barber's shop and he submitted to the loss of his beard. This occupied till 11 o'clock, a.m., and when the usual dinner-hour arrived, he was ready to join his confederates in the dining-room.

It will be remembered that the Clerk of the Court asked Huntington, after Justice Capron had pronounced his sentence, the usual question if he had any mechanical trade, and was answered in the negative. It seems that he was formerly engaged, for three years, in the furniture business, somewhere in Hudson Street, and on the strength of this he has been assigned to the cabinet shop at the prison, under the contract of Mr. C. H. Woodruff. He is engaged in the simple operation of sawing and planing boards. His constitution is said to be much run down, and his countenance looks care-worn and haggard.

## Popular Mechanics June, 1902

### MAKE LEATHER NOVELTIES FROM HUMAN SKIN.

**Ghoulish Fad of the South Making Its Way to the North—  
May Become a New Industry.**

Gloves, hand bags, belts and watch fobs made of human skin are possessed by many people in the South as curiosities. The articles are nearly all made of negro's skin artistically tanned. Mr. A. H. Lockwood, of Chicago, recently received the following message from Louisville, Ky., inclosed with a most beautiful piece of leather:

"I send you a small piece of leather made from the hide of a Kentucky negro. I tanned some pieces for students and I hope you will accept the piece I send you as a novelty."

Mr. Lockwood, who is an authority on leather, says: "A man's work may live after him, why not his hide. There are some who have been making a great fuss about this pretty work on human skin as if preservation were a crime."

The skin makes a thin but soft and substantial leather. In quality it is nearly equal to kid. There is no difference between the skin of a white person and a negro as far as the quality of the tanned leather is concerned. It is reported that the practice of making articles from human skin is making its way to the North and that the hides of white persons are now serving as pocket books and leather cases. Soon it may be so that our cuticles will live on in the form of slippers to make merry in the dance halls, or may be to protect the "mit" of a prize-fighter, years after the breath has left our bodies.

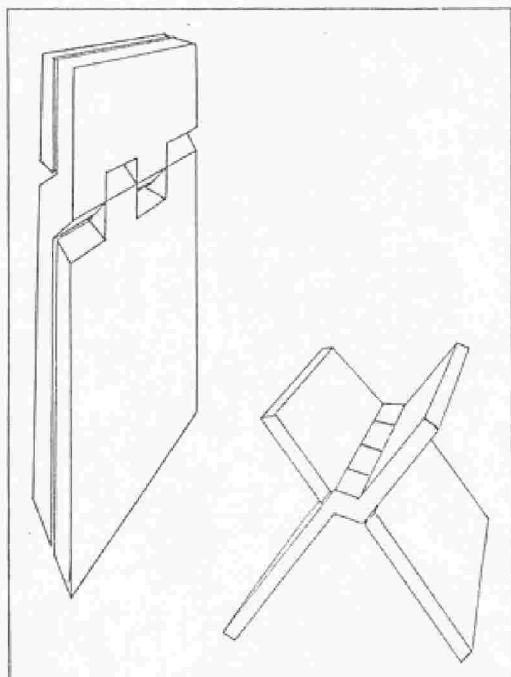

## SIMPLE RIFLE REST

By A. HARNETT (England)

THE AMERICAN RIFLEMAN, MAY, 1940

HAVING made use of many helpful suggestions in this journal, may I offer its readers the design of an easily made rifle rest which has the advantages of portability and no cost, and can be used on soft grass or hard concrete.

Take a piece of hard wood about 8"x2 $\frac{3}{4}$ "x1", draw a line across the face 2 $\frac{3}{4}$ " from one end, and lines on either side of that line half the thickness of the wood distant. Across these lines divide the width of the wood into four, making eight rectangles.

Cut out wedges to a depth of half the thickness of the wood from alternate rectangles, sloping away from the centre line.

Do the same on the back of the wood, cutting out wedges from the rectangles uncut on the face.

Halve the thickness of the wood with a saw cut from each end until the wedge-cuts are reached, and divide the edges of the wedge-cuts with a thin knife.

The piece will then open to form a X rest.

Although it sounds rather complicated it is a very easy job, and a rifle stand which can be carried in the pocket is the result.

I should have sent you one of these stands to try but, not knowing your import laws, I am loath to cause you to pay duty on a small piece of wood.

## BEWARE UNSCRUPULOUS BOOK DEALERS

Several years ago when I began getting a lot of publicity warning of civilization coming apart, a particularly corrupt branch of the sucker-book field was established. The "suckers" these books are directed at are those who know things are bad and are getting worse.

To such book dealers as Delta/Desert, Paladin Press, Loompanics Unlimited and Butokukai, those who would prepare for an uncertain future are fair game. They reasoned that since this class of suckers was only fantasizing, it was all right to just feed those fantasies.

They needed no real knowledge, accuracy was unnecessary and any material which could be passed off as secret, underground, classified, dangerous, was sucker-bait. Books on destructive devices are falsely advertised as CIA, Frankford Arsenal, real super stuff! Most of their material on improvised weaponry is not CIA, etc., but simply from military manuals.

Actually, I already have all the better material from the military manuals in the Poor Man's James Bond series. What they advertise as real Terminator material is mostly what I rejected as uninteresting or impractical in light of better methods. But this same uninteresting, unimportant and impractical material can still be sold to suckers. Then there is that material written by ignorant jerks who don't know their subjects and couldn't sell their material to ethical publishers. But if it reads well to a child, the suckers will buy it.

Other books, or booklets, as most of them really are, are just plain silly. Like Desert's "Improvised Batteries and Detonating Devices." This is a hodge-podge of impractical information, some even unrelated to the title. Page 2 has "GELS: Oil Gelation in automobile engines causes permanent damage to moving parts due to oil starvation. The most successful gelling agent among those tested is N-coco-y-hydroxybutyramide. This substance can be added to the engine oil pre-synthesized, or it can be formed in situ by the reaction between coco amine and butyrolactone.

"A Polyacrylamide gelling agent was used to completely gal an automobile engine cooling system."

Why would the scientist who could understand that and get it be messing with people's car engines? I've never heard of it. But the clincher is that the stuff doesn't even work before 18 or more hours.

The parts on batteries are extremely technical and require a much higher education in chemistry and electronics than the line soldier or average man possesses. It wasn't tailored for just anyone who can

read, as books on anything improvised should be. In short, unless you have a really good background in science and have access to materials even I would find hard to get, the booklet is worthless.

ANOTHER example is "Improvised Munitions Black Book Vol. 3." Pages 13-15 describe a grenade made up of a short piece of pipe threaded on both ends and capped. It's filled with dry potassium chlorate, sulphur and ball bearings and will explode on impact. The reader is cautioned not to use it after five days. Bad!

When sulphur is exposed to oxygen, molecules of sulfuric acid are formed which can explode potassium chlorate. Pure sulphur doesn't react spontaneously with potassium chlorate.

Pure sulphur is that which has not been exposed to the air. Raw sulphur is burned and the fumes are condensed in a large hood. The "flowers of sulphur" are scraped off and packaged airtight when meant for fireworks or explosives makers. They know it has not been exposed to air. But how do you know the sulphur you're using has not been exposed to air for who knows how long before being packaged as garden sulphur or uses other than for explosives?

It's still fine for gunpowder or most any fireworks not using dry potassium chlorate. Still, you don't know if it's dangerous for a grenade, even if you've just opened the package. The device is stupid and extremely dangerous to its maker. At any rate, never mix dry sulphur with dry potassium chlorate.

That book is filled with seemingly clever items but hard to get ingredients. It's dangerous, impractical and filled with overly complicated processes.

Then there's Paladin's "Hit Man." I think the writer meant to discourage any reader from actually hurting anyone. The main emphasis is on not getting caught, making the hit man so paranoid and overly cautious that the job would never get done. If anyone tries to kill me, I hope he goes by that book.

A real clunker is "The Anarchist Cookbook." Its author was a real anarchist and just wanted to cause trouble. But he had no knowledge of the material. The book is a mish-mash of useless formulas and outdated weaponry. Also, he filled about half the book with instructions for making drugs. Weapons and drugs don't mix and any reader would have to be high on LSD to be stupid enough to shoot a molotov cocktail from a shotgun.

I read the silly book years ago and reasoned that if anyone could sell such trash I could do better. So I wrote the Poor Man's James Bond. The rest is history.

Now for the Ninja books. Lies grown from myths. If you want to be a ninja warrior I'll tell you what to do. Take off your shoes and socks, put a bag over your head and bounce off your walls for at least an hour per

After a few sessions you'll be as good at ninja as anyone who has ever depended on those idiotic ninja books to learn martial arts.

You don't learn martial arts by reading. Get with a buddy and practice the moves and holds of the Ju-Jitsu and the Army Marine hand-to-hand combat in PMJB I and U.S. Militia. A few weeks practice in your spare time will make you more than a match for any undisciplined punk you meet.

But if you want to go on to make martial arts a part of your life, you'll have to join a karate, kung-fu or tae-kwon-do school near you. In the real world of martial arts it's instruction by a professional and practice, not fantasizing through books written for suckers.

Then there are the detective books for super spies and secret squirrels. I challenge anyone to find a real private investigator who got his start by reading even the best of those books. If that's your interest, look up "Private Investigator" in your phone book and visit a real private detective.

It's mainly drudgery, not really romantic, and very down-to-earth. The person you talk to will tell you the real way to become a detective and he may hire and train you if you're needed. If he's a good guy, and he probably is, he'll set you straight one way or the other.

Then there are the lock-picking books. Think. If you want to get in someplace, isn't it easier to kick in the door, break a panel, jimmy a window? Of course, your fantasy is to pick a lock, enter and get valuable papers, and leave without anyone knowing you were there. How many books, how many sets of lock picks will you buy and how many hours of practice on your own common locks will you waste learning this useless pursuit.

Several years ago I took a locksmithing course I saw advertised in Popular Mechanics. The first lesson showed how to make a key for one of those locks made up of layers of metal. The idea was to hold a blank key over a candle and cover it with soot. When the key was pushed in the lock and twisted the insides would take off the soot at the right points. After using a thin, flat file to file those places the key would open the lock. It worked.

The second lesson came with a practice lock and I learned about it but it was too involved. Since I didn't really want to be a professional locksmith I sent the lessons back, telling them I didn't want back what I'd paid but I didn't want any more.

If you're serious and want to be a locksmith, get a professional course as I did. By the time you've finished it you'll be locksmith. You can set yourself up or hire out to an established locksmith. Other than this is just silliness.

Now about those revenge books. Some of the ideas are clever but too few are practical to make the books worth their cost. You could get the same quality of practical jokes and dirty tricks by inviting a few guys over to kill a keg of beer.

While researching my article on Clarence's visit to Washington I learned the glories of Super-Glu. Treat your enemy's car and door locks to a squirt of liquid Super-Glu. Fifteen seconds and the lock has to be replaced. Just think of the possibilities. And it's available in most stores and supermarkets.

Choose your victim. While at work, find his car and Super-Glu his locks. Then while he's deciding to break a window to crawl through or call someone to take a door off, you drive to his home and Super-Glu his door locks. You might even stop off at the Post Office and close his box.

This would be an awful way to treat a guy but you could turn his life around, undetected, with one small tube of glue. A tube of such glue could also disrupt businesses of all kinds as they couldn't open up in the morning.

For a pure practical joke with Super-Glu, follow your victim around until he sits down. Of course, this would mean going with him to a bar for drinks or to a restaurant, or in the office as you accompany him to his desk. Naturally, this would mean he's not a blood enemy. Of course, you don't want him to make the connection of you being nearby when it happened. But you've got fifteen seconds, remember?

A few seconds before you know he's going to sit down, squirt some Super-Glu on the seat. It's thin and there wouldn't be enough of it for him to feel through his pants. Now, he's going to have to get out of his pants, maybe even his shorts, to get up. Imagine and enjoy.

Super-Glu is terrible stuff. In Houston, a woman couldn't get the top off a tube she'd used. She put the cap in her mouth to hold it tight so she could twist it better. The tube split and it squirted all over her lips. She had to go to the emergency ward where they actually slit her lips open with a scalpel. Super-Glu is not to be fooled with.

If you have any good practical jokes or dirty tricks you know would work and aren't complicated, send them in.

Getting back to the subject of bad books—the titles and categories I've listed are not exceptions, they're typical. You're safest by not buying anything at all from dealers who will sell such books, regardless of whatever else they sell. A Canadian who called said he'd bought a bunch of books from Paladin Press and was so angry and disappointed he threw them away. I'd have sent them back.

You ought to realize that the people who publish such trash don't care if the books are inaccurate.

They rely on your lack of understanding to make you think you just bought something you weren't ready for.

There are two reasons you may not understand a book you get from such dealers. The book may be good but very technical. Of course, the ad for it leads you to believe it was written just for you. That's deceptive advertising.

You may buy the book and decide to study up on the subject later. It's unlikely but you might. But what if the book was written by some phoney who counts on you to think you're too dumb to understand it, when actually, you don't understand it because it simply doesn't make any sense? If you don't realize this you may be in danger. This can come about when you think you have what you need on a subject, only to find out it's garbage when you or your friends use it. That's too late.

Incidentally, if you find any errors in my works, I want to know about them. I'll print the corrections here and also put the corrections in the next printing.

## THE BEST KING EVER

By Kurt Saxon

A man went to a far land and was delighted. The place was so clean, the people were so happy, productive and industrious. The man commented to a native what a well-run country he had. The native was pleased and said the king would be glad to hear that.

"In fact," said the native, "would you like to dine with the king? He loves to entertain people who think well of his country."

The man said he would enjoy meeting the king and they went to the palace. The king greeted him warmly and they had a fine dinner and talked well into the afternoon.

When the man figured it was time to go the king smiled and said, "You seem to be an intelligent fellow. How would you like to replace me as king?"

The man was astonished but had always been quick to grasp an opportunity. "Sure, I'd like to be king. What do I have to do?"

"Well," said the king, "you just take hold of this medallion on my chest. It's very complex, very scientific. I don't really understand it. Anyway, once you grasp it my vibrations are cancelled out and yours are in it."

The man grasped the medallion and after a minute the king took the chain from around his neck and hung the medallion around the man's neck.

"Now, you're king," said the ex-king. "Just make sure you never let this medallion get more than two feet from your body or it'll explode. It's very scientific. It'll blow you to bits. And don't tinker with it, either. That would set it off."

The new king just about collapsed. "You set me up. I'm going to die," he said disappointedly.

"Nonsense," said the ex-king. "Just keep the medallion on and you'll be safe. I've been king for three and a half years. Came from Iowa. Just see that the country's run right and nothing can go wrong. You'll have advisors and the constitution says the government does just as you want."

"And what if I don't want to be king and what if I don't run the country properly?" asked the new king.

"Well," said the ex-king, "you're king until you pass on the medallion, probably to another tourist. And if you don't run the country properly, some angry citizen will go to the square and push the button by the fountain and your medallion will explode. It's very scientific."

The new king was getting angry. "But what about some crazy person or moron coming along and pushing that button?"

"Not likely," said the ex-king. "Our people are tested early as kids. Any who are slow are sterilized and watched over. The ones who are likely to become mean are put to sleep. Besides, in the last three generations since the system's been in place, less and less defectives are born. We have hardly any crime. No jails, little sickness, no poverty and no taxes."

"Then you must have political enemies, people who want power," said the new king.

"No," said the ex-king. "If the king were killed, everyone in the government would be replaced and everything they owned would be forfeited. Any replacements would be subject to the same rules. The system works. Everyone has all he needs and more. Even me. I've got everything the country has to offer—wine, women and song. I haven't wanted for anything since I took the medallion from the last king."

"Then why do you want out?" asked the new king.

"Because," said the ex-king patiently, "perfection is boring. No challenge. Now I'll get a hundred acre farm. The last king got a roller skate factory. Besides, you never can tell, someone might push that button."

The new king saw the ex-king out of the palace. He looked around the throne at the smiling girls in attendance. He smiled, too. He thought to himself, "Who wants a skate factory? I think I just might be the best king ever."

### Popular Mechanics June, 1903

According to a technical paper very good "lemonade" can be made from sea water by the use of citric acid, which precipitates the salt, the remainder being harmless mineral water. Seven ounces of citric acid will supply one man with marine lemonade for one week. Persons about to be shipwrecked should provide themselves with this prescription.



In the camp at Sagan, Major Orris and his fellow prisoners provided for their needs with homemade equipment described on the following pages. At the right is their symbolic version of AAF wings.



# Yankee Ingenuity Licks Prison-Camp Hardships

POPULAR SCIENCE JULY, 1945

By VOLTA TORREY

MAJ. WILLIAM ORRIS bailed out into captivity five weeks before D-day, was a prisoner for over 11 months.

FOR Maj. William Orris and hundreds of other American airmen, being captured by the Germans was like being stranded in an incredibly weird and inadequate world. They were always hungry. They had no tools, and scarcely any material except tin cans. Yet they re-equipped themselves with nearly as many things as a novelty store sells—and they pulled through.

Orris is a tall, bright-eyed pilot who parachuted into the enemy's custody five weeks before D-day and escaped three weeks before VE-day. His B-24 was hit by flak in a bombing run over Toulon. Blinded and nauseated by gasoline fumes, he went out



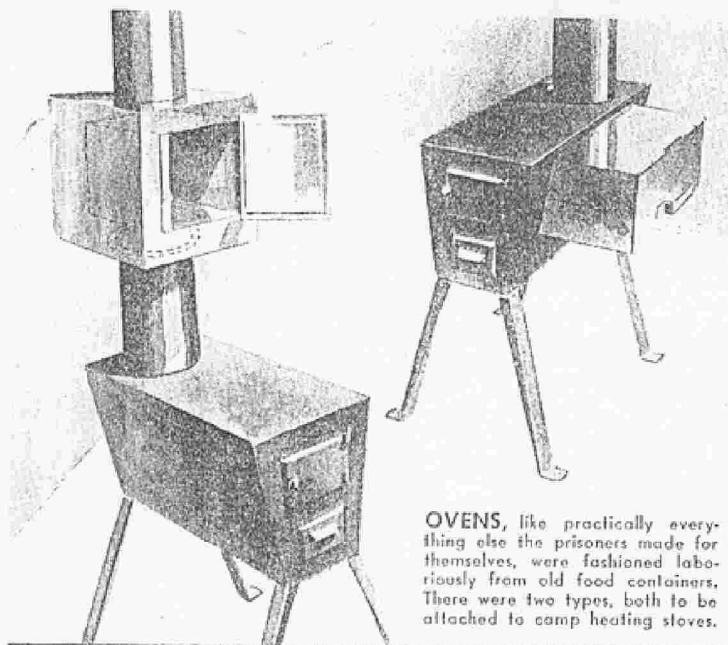

**OVENS**, like practically everything else the prisoners made for themselves, were fashioned laboriously from old food containers. There were two types, both to be attached to camp heating stoves.

**ICE-CREAM FREEZER** was one of the most elaborate kitchen utensils produced by the "kriegies." Tin paddles attached to a tube were rotated by pushing the bow to and fro. Ice cream was enjoyed only in the winter, when ice was plentiful—outdoors. All the tin used came from containers no bigger than coffee cans, cut and joined as shown below.

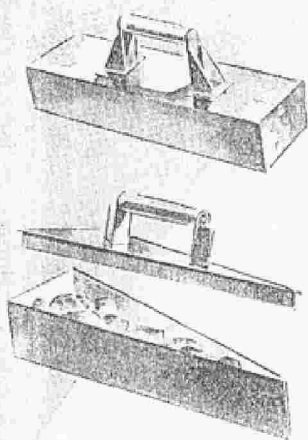

**FLATIRONS** were tin boxes which were filled with hot coals. Two styles are seen above. The prisoners had such clothes as they were captured in, plus some "booty" garments of various kinds that the Germans seized and issued to them. They did their own washing and pressing.

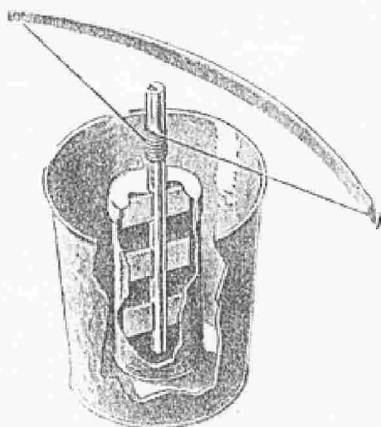

through the bomb bay and lit in a tree beside German headquarters. Looking back, he saw his own plane explode and the rest of his squadron disappear beyond the horizon. "Boy," he says, "I sure felt lonely."

But the Major was luckier than many kriegies (war prisoners of the Nazis). He learned the next morning that his crew was safe. He was questioned cunningly and paraded before French and German civilians. But he was not tortured, and he believes the Luftwaffe's prison camp at Sagan, southeast of Berlin, in which he was confined for the next eight months, was one of the best in Germany.

Even so, the food at this camp was neither good nor sufficient. But at first each man got a Red Cross parcel once a week, and Orris received one of the two dozen packages that his family sent, and about a fifth of the mail addressed to him from America.

With tin cans as shovels, the boys leveled two baseball diamonds for themselves and cleaned out a water tank to swim in. But they soon talked and dreamed more about food than about sports or home or girls. Planning future menus was a favorite occupation, and Orris is carrying out those plans now. While talking to **POPULAR SCIENCE MONTHLY'S** editors, he lunched on a fruit cocktail, two helpings of roast duck with all the



trimmings, and a strawberry shortcake smothered in ice cream.

On a typical day while he was a PW, his breakfast was a cup of poor coffee and two slices of toasted but sour black bread, as thin as Melba toast. Lunch was another slice of bread and a bowl of barley soup as tasty as dishwater. And the day's big meal was half a bowl of potatoes and cabbage with just enough meat to whet a soldier's appetite.

The kriegies were required to punch two holes immediately in every can of food they received from the Red Cross. This was to keep them from saving some for attempts to escape. Another result was that much of the food spoiled, and many men had dysentery.

When a rabbit came through the barbed wire, 70 or 80 of the imprisoned airmen would chase it like dogs. Even three cats that were pets of the prisoners were sacrificed after days of discussion and planning. One man was detailed to stun each cat with a club, another to skin it, and so on. The first man did not hit his cat hard enough, and it got away, but finally the disagreeable job was done, and the men who ate the cat meat said it was good.

The Germans let them have gardens, which they spaded and raked with tin cans. But the soil was miserable, and American officers solemnly followed the horses whenever a wagon entered the camp, waiting for manure. They even built a trap to jolt the cart that carried waste away from the latrine, and salvaged the stuff that spilled out as fertilizer.

When a kriegie found a nail, he kept it in his watch pocket and took it to bed with him, because it was a precious tool. They had table knives, forks, and spoons, but no pliers, screwdrivers, or hammers. Yet, in addition to doing their own cooking, they had to improvise the utensils.

Their cooking was economical. They saved prune pits, for example, extracted the seeds, and cooked them in margarine to make a dessert. "It tasted like almonds," says Major Orris. Coal was so scarce that they dug up stumps and roots from the prison grounds for fuel, and made "kriegie burners" out of tin cans. These were tiny contraptions that enabled them to get the maximum heat from leaves and twigs.

These PW's could not buy anything, but they ran a store where they swapped whatever they happened to have. The storekeepers set point values on everything, and some men soon learned to play the market. When smokes were fairly plentiful, they stocked up with cigarettes, held them until the point value rose, then traded them for soap or whatever else was offered.

Others turned to handicrafts. Some saved metal from the tops of cans, made moks fromAAF insignia, and cast new badges for those who had lost the wings from their shirts. A popular variation was an insignie with one wing clipped off and a tiny eight ball hung on a chain in its place.

Some men made knit-

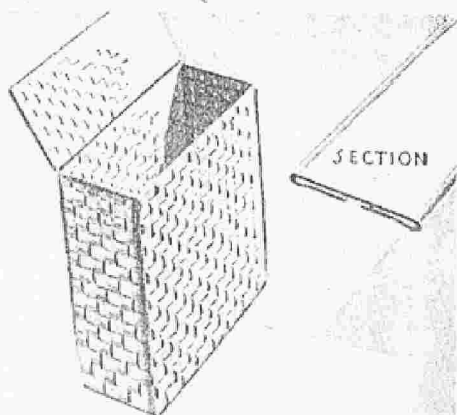

**CIGARETTE CASES** woven of tin strips were among the fanciest products of kriegie handicraft. Tin was cut into narrow strips, turned over at the edges as seen in the sectional view, and woven.

ting needles out of bucket handles, then knit scarfs, sweaters, and gloves, to have something to swap. One man made himself a tin suitcase, and another built a toy steamboat that ran on a spoonful of margarine.

Desperate amusement seekers made kites out of toilet paper, until the Germans declared this sport *verboten*. Then, lying in his bed one day, Major Orris saw a fly come in his window with a glider in tow. It was a tiny piece of paper, folded the way schoolboys fold sheets into toy airplanes, and attached to the fly by a thread. From then on, the imprisoned airmen had glider contests with the flies as tow planes.

During his year in Hitlerland, Orris saw only two movies. One was from Hollywood, "The Male Animal," and the other a propaganda film about the beautiful scenery in Germany. "You can imagine how we felt about *that*," he grins. But the kriegies made a curtain by sewing blankets together and put on stage shows for themselves. A loud-speaker blared German broadcasts at them, and they published two camp newspapers, lettering them by hand and posting them on the wall.

At Christmas, the kriegies scraped wax from the paper wrapped around food and made candles. Major Orris thinned the paint from a box of children's water colors and decorated his window. Soon, nearly all the windows in the camp were gaily painted, but the prisoners got no "bash" (extra big meal) on the holiday.

By January, they could hear the guns on the Eastern Front. The camp was near the Oder, and the Russians were coming that

way. On an hour's notice, in the middle of the night, the kriegies were marched out into a snowstorm, with the temperature 10 below zero.

All the rest of the night, led by a horse and wagon, they marched three abreast in a column more than a mile long. Trails of blood were left by the bleeding feet of the horses and the guards' dogs. When a plane swooped low as though about to strafe the marchers, some men dived toward the woods, and the guards opened fire on them. Stragglers, whether guards or prisoners, were just left behind. One guard carried his police dog in his arms for warmth; other guards fell in the snow.

Polish women enslaved by the Nazis looked out of a factory window that dawn and wept when they saw the bedraggled, motley line of prisoners tramping down a side road. The men were billeted that day in a barren, dusty room over a pottery works; other days they slept in barns, and once on a woodpile. The snow turned to rain, and the crude sleds on which some of them dragged their packs had to be discarded.

**CRACKER MILL** provided flour for making pies. Crackers were pressed against a rotating cylinder on which teeth had been raised with a nail. Flour dropped into the bottom section.

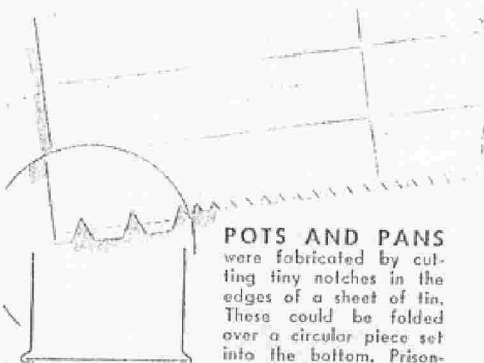
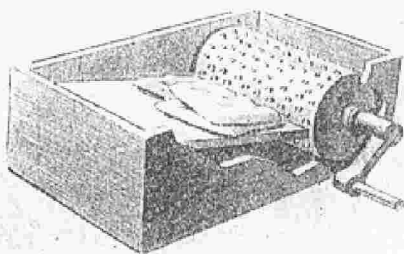

**POTS AND PANS** were fabricated by cutting tiny notches in the edges of a sheet of tin. These could be folded over a circular piece set into the bottom. Prisoners' only tools were table knives, forks, and spoons.

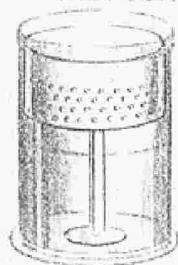

**PERCOLATOR** fashioned in this manner gave Yanks their breakfast coffee. A nail was used in punching the holes for the basket. Nails were treasured. If a prisoner found one, he put it in his watch pocket and took it to bed.

Many had fatigue visions of rosy sunsets, fireworks in the sky, and beautiful green pastures. Eventually they were herded into cattle cars. The 50 men in the car with Orris found they could all lie down at once if they carefully knit their bodies together, and they jolted on across Germany to Nuremberg.

There the weary, underfed, sick, and dirty men were soon covered with vermin and bites, because the cells into which they were dumped had not been cleaned. They received fewer Red Cross parcels, and the soup was often full of weevils. "The more weevils we got," says the Major, "the better we liked it. That was our meat ration." Some of the men became so weak they seldom left their bunks. "They blacked out," Orris explains, "if they stood up quickly."

American planes bombed the big railroad yards just beyond the prison fence. At Sagan, some men had been shot for rushing out and showing enthusiasm during air raids. But here they were allowed to sit on the sandbags and watch the fireworks while the guards ducked into slit trenches.

Major Orris and another kriegie escaped while being marched out of this camp, fled to the woods, built themselves a lean-to, and waited. They were afraid they'd be caught if they moved on—and Patch was coming toward them.

For two weeks they waited, listening to the guns, and living on scraps of food left by German troops who camped near by. They found other escaped prisoners in the woods, and played bridge two evenings with a couple of Englishmen. But the days seemed endless, so they risked moving on toward the northwest—and almost ran into a tank concealed in the brush.

Neither of them had ever seen that kind of a tank, so they supposed it was German and backed away fast. But when they peeked out farther on at an autobahn, they saw a long column of such tanks rumbling toward them—and the faces beneath the helmets of the men on the first tank were black.

"We just about cried," says the Major, "because when we saw that they were Negroes, we knew we were free."



# Military Issue Kevlar Frag Vest

by Christopher Maxwell

Current issue U.S. military fragmentation protective vests are made from Kevlar rather than the nylon material of earlier models. This has attracted much interest from those who live and work in areas which may be subject to civil disturbances or violent crime.

Military reports from Grenada, Panama, and the Gulf War all agreed that the new vest is far superior for military purposes. Our question was whether it has any civilian application.

Commercial soft body armor which offers equal coverage area to this vest is priced anywhere from \$400 to \$1000. Surplus frag vests are much less expensive if the vests will stop bullets from the weapons commonly used by criminals, looters and rioters. Surplus frag vests might be a real bargain for those who can't afford the commercial armor or don't need body armor on a daily basis.

After a little shopping around, I found the best prices at Sierra Supply, Box 1390, Durango, CO 81302. I obtained used vests in good serviceable condition for under \$100. That lot will be sold out by the time you read this, but more lots of surplus vests will be available. Call Sierra at (303) 259-1822 or write for current prices and availability.

My first impression of these vests was that they are much more comfortable and better designed than the old lace-up nylon frag vest we had in Nam. The sections are connected by elastic straps and overlap at all joints, providing full side and shoulder protection. The shoulders are separate sections, connected to the front and back sections by elastic straps, which provide much greater freedom of movement. The whole mess is still heavy, 8 to 10 pounds depending on size. But the distribution is very good and it doesn't feel that heavy.

The vest only extends to just below the belt line. This is good for mobility and wearability, but leaves some of your favorite parts unprotected, as well as the femoral artery. Body armor which protects down past the groin would make it very difficult to sit or crouch 90% coverage on your body works better than 100% coverage in your closet.

The shell of the vest is water repellent nylon and there is a row of drain holes around the lower inside. The Kevlar inserts are sewn in place inside the shell by numerous bar tackings to reduce the possibility of the material "bunching up" and leaving an area unprotected. The front sections overlap 2 inches and close with multiple velcro closures.

The front, back and shoulder sections of the vest were found to contain twelve layers of kevlar fabric. The collar sections contains six layers. Three layers of kevlar are sewn together over the edges to prevent unraveling, then two or four of these three ply pieces are sewn into the shell together.

Commercial body armor usually contains ten or more layers of Kevlar, except for the lightweight Nashville vest which contains seven. The vest used by the Metro Nashville

Police has been found to be very effective and has saved many lives. In addition, most commercial vests do not cover the entire torso as the frag vest does.

There are external bellow pockets on each side of the vest 5" wide by 6" deep with a velcro closure on the flap the label also forms a pocket on the inside in the center of the back. An instruction booklet was found in this pocket. It offers the following information.

"The vest does not protect you against small arms fire. It may tend to decrease the severity of wounds from rifles and machine guns and will sometimes stop small arms fire if hit from an angle or if the slug has low velocity."

When the Army says small arms fire, they mean 7.62mm rifles and machine guns with FMJ bullets. Center fire rifles account for a very small percentage of shootings in the U.S. Commercial body armor which is intended to stop high power rifle bullets weighs from 30 to 50 pounds and contains steel armor plates along with Kevlar and other materials. Since most criminal shootings in the U.S. involve handguns and shotguns, that is what I tested for.

Despite all the media nonsense about assault weapons the most criminally used firearms among criminals are still 25 autos, and 2" .38 revolvers. Small calibers like .22, 32, and .380 are more common among street criminals than 9mm and .357. When a rifle or shotgun falls into the hands of a criminal, the barrel is usually sawed off at the end of the forend. While this may make the weapon easier to transport and conceal, it reduces the power and accuracy as the front sight is also removed.

In my test, the sections of the vest were separated and set upright against a backing of telephone books. Those who are unsatisfied with this procedure are encouraged to volunteer for the next round of tests.

The handguns were fired at ten feet and the rifles and shotgun were fired at twenty feet. This should provide a realistic evaluation of how these vests might perform in typical civilian self-defence incidents.





Even the .357 Magnum had to be fired from a rifle for complete penetration. I did not have a 9mm carbine available for testing, but I think we can make some valid estimates of how it might perform.

9mm ammunition only gains 10 to 15% in velocity when fired from a 16" barrel, unlike the .357 which may gain 40% or more. The revolver cartridges are loaded by the factories with slower powder than the 9mm, so the extra barrel length really allows more burn time for the powder to push the bullet. That's why you get such a flash with the .357 revolver. That's the rest of your powder burning after the bullet is gone. Plus, there is no cylinder gap to close up with the 9mm. Firing a .357 from an unvented test barrel the same length as a revolver barrel and cylinder produces velocities up to 100 feet per second higher.

So I think it safe to say the improvement in performance of the 9mm in a carbine would not be as great as the improvement seen with the .357 Magnum. The expanding bullets would probably not penetrate much more than they did from a pistol, and the FMJ bullets might just barely make it through the vest. At any rate, the vest would reduce the injury considerably.

Repeated impacts were found to reduce the ability of the vest to resist subsequent shots. The reduction is not enough to make the vest useless, but does indicate you should not test a vest you plan to wear, and any vest which is shot should be replaced and put away as a reserve.

The fourth round of 9mm ball fired into a 2" circle went through the vest. The phone book was shredded for 3" deep and 3" in diameter. The bullet which finally penetrated went 4" into the phone books.

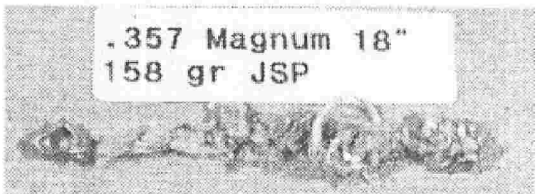

From the result with the .357 Magnum carbine we see that most center fire rifle cartridges will penetrate this vest even with soft point bullets, at least at close range and straight on shots. In the unlikely event of being confronted by a criminal with a high powered rifle with the barrel still at its original length, this vest won't stop his bullets. It may reduce the severity of any wound received, and may stop an angled shot.

I made no attempt to assess "blunt trauma" because to the best of my knowledge and belief, no one has died of blunt trauma caused by a non-penetrating impact on soft body armor. Some of these impacts would hurt and others would cause internal injury, but you would live to complain about it.

I don't know what the federal standards are for backface deformation for bullet protective vests. I know I would rather have bruises or broken ribs than a sucking chest wound.

Even in cases where the vest is penetrated, the injury would be much worse without the vest. Getting shot is not a good idea, even while wearing body armor. But if you are in a situation where you might get shot, body armor can make the difference between life and death.

I conducted stabbing and slashing tests on the remains of the vests with very encouraging results. Slashing at one of these vests is a complete waste of time. Stabbing is little better. The only thing I was able to stab completely through, without using enough force to push a standing man away, was with an ice pick. I was also able to push the point of a dagger through, but anyone trying to stab through one of these vests with a knife, would knock you down before the knife went through.

The sizes allow for wear over normal clothing. If you want to keep one of these around to throw on over your jacket and/or as a concealable vest when things get exciting, then one size larger should give you plenty of room.

If you want concealable body armor but can't afford the commercial variety, you can take one of these apart and make your own. I sewed the Kevlar panels from one of these vests into a nylon windbreaker to make my own "raid jacket".

I also molded the remains of the shot-up sections of the 2 vests used in this test into a panel of resin plastic to make my own riot shield. After separating the layers and overlapping to cover all holes and edges, I ended up with a 24" x 48" plastic shield with 18 to 20 layers of Kevlar imbedded. This should stop any standard handgun bullet, and even some rifle bullets.

The Australian outlaw Ned Kelley had a suit of steel armor which was proof against the lead bullets and black powder loads of his day. He was brought down by buckshot to the legs. We'll never know if that was good thinking or bad shooting by the deputy who got Ned, but the results were the same either way.

This vest won't make you into superman, but it can give you an edge if your adversaries don't know you are wearing it or don't know what it is. If you are attacked by someone wearing one of these vests, and you are not armed with a high-powered centerfire rifle, you better shoot for the head or thighs.

I try to stay out of the type of places and situations where I might need body armor. Since my crystal ball isn't working too well, one of these has a permanent home in my closet and another in my car trunk. You can have body armor which will protect your entire torso from the weapons commonly used by criminals for less than the cost of a few magazines or a few boxes of ammo. It's a lot of protection for the price.

CARTRIDGE	BARREL	PENETRATION
.22LR HV	2"	bullet stuck in surface
	5"	5 layers penetrated
	22"	6 layers penetrated
.22LR Viper	22"	5 layers penetrated
.22LR Stinger	22"	4 layers penetrated
.32 S&W Long RNL	3"	bullet bounced off
.32 ACP 71gr FMJ Silvertip	3.5"	4 layers penetrated 1 layer penetrated
.380 95gr FMJ Silvertip	3.5"	3 layers penetrated
		2 layers penetrated
.38 Special +P 158gr SWC-HP 125gr Nyclad 125gr Kinetic High Impact	4"	1 layer penetrated
		1 layer penetrated
		pulled layers through shell, 1" into phone book
9mm NATO 124gr FMJ-RN 124gr FMJ-FP 115gr JHP	5"	8 layers penetrated
		8 layers penetrated
		5 layers penetrated
.357 Magnum Revolver 4" 125gr JHP 158gr JSP	18"	7 layers penetrated
		10 layers penetrated
.357 Magnum Carbine 125gr JHP 158gr JSP	18"	pulled layers through shell, 2" into phone book
		complete penetration, jacket separated, core pulled strands of kevlar and 3" into phone book
.45 ACP 230gr FMJ-RN 200gr JHP	5"	bounced off
		4 layers penetrated
12 GAUGE 00 BUCKSHOT	20"	Some pellets penetrated 3, 4 and 5 layers, two penetrated 6 and one 7. This is as close as I can tell from the mess it made of the impact area. Phone book was shredded for 2" deep & 6" in diameter. OUCH!

many cases. This doesn't mean four layers would have been enough. Many rounds which were stopped in the sixth layer of the twelve layer sections, did penetrate the six layer collar section.

Full jacketed bullets were deformed as if they had been fired into a hard target. In most cases the FMJ bullets penetrated more than the hollow points.

Longer barrels and higher velocities did not cause significant improvement in penetration for the .22 LR cartridge in this vest. The higher velocity caused the bullets to expand more, spreading their impact over an even larger area. The .22 LR fired from a rifle penetrated the six layer collar section, but did not have much energy left after that.

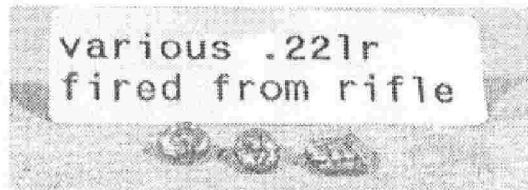

The .22 Magnum fired from a rifle might penetrate this vest if the bullet is considerably harder than the bullet used in the 22 LR. I don't think the soft bullet used in the .22 LR could be forced through all twelve layers at any velocity, it would disintegrate first.

The Winchester Silvertip has proven to be the most effective stopper in .32acp and .380acp. In .38 Special, the two most effective loads on the street have been the 158gr +P lead hollow point and the +P 125gr Nyclad hollow point. None of these would even penetrate the six layer collar of this flak vest.

While no .38 special ammunition penetrated the vest, the Kinetic High Impact came close. It did more damage to the vest and phone book than the .357 Magnum from a 4" barrel. This ammunition comes from a small company (Kinetic PO Box 765, Tavernier, FL 33070) and the manufacturer states it will penetrate a type IIA vest. Unlike many "armor piercing" bullets it is a lead alloy, so it is legal. I don't know why it works, but it does. The two stage bullet is patented and somehow provides both penetration and expansion. Get yours now, before they're banned.

9mm automatics are becoming more common. At least on TV, but this vest performed quite well against the 9mm also.

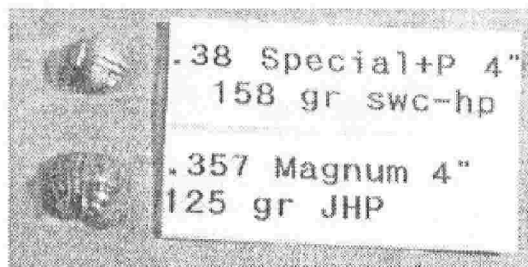

Expanding bullets tended to expand in the first and second layers, spreading their impact over a larger area of the remaining layers. The third or fourth layer stopped them in

THE MECHANICAL PACKAGE MAGAZINE

# Army Type Air Pistol Easy to Build

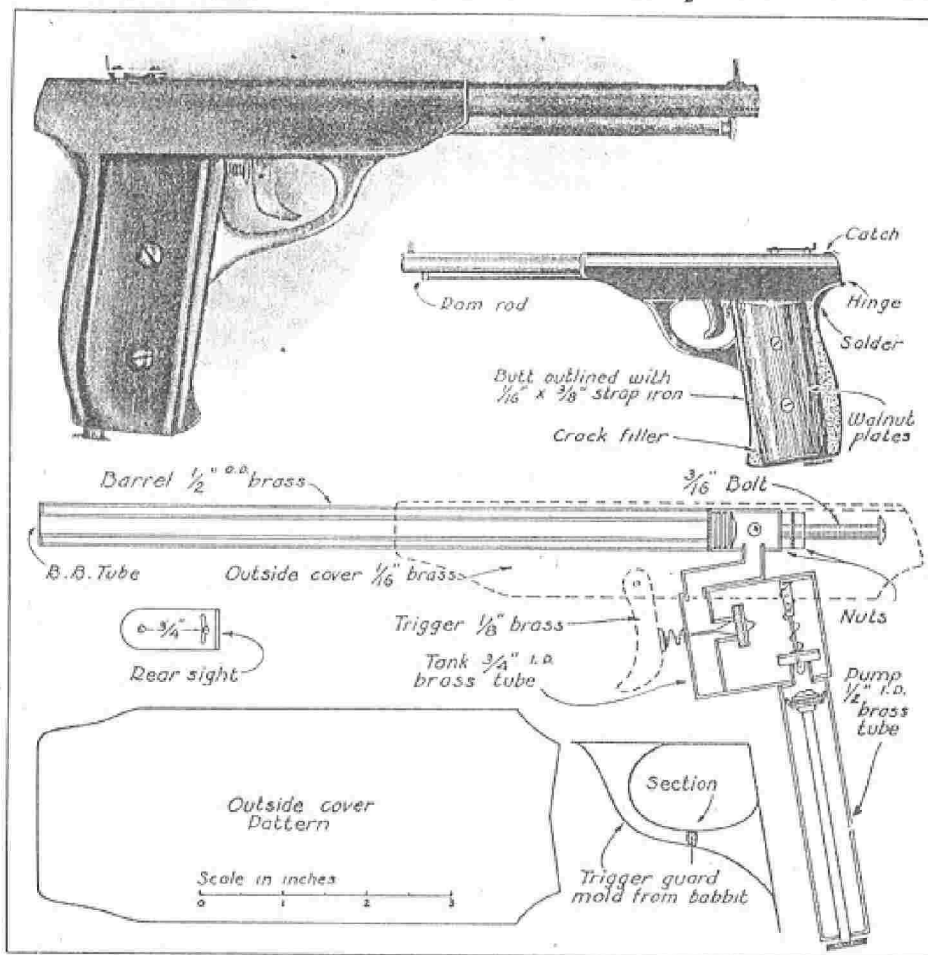

Built of tubing and odds and ends of strap metal, this air pistol will be found to be quite powerful. One was actually built at the Packmag Experiment Station as pictured and gave good results. Gun is muzzle loading.

**S**ERIOUSLY surprising are the shooting qualities of this home-designed, home-made air pistol.

The idea for the gun came to Slide Rule Sam through a piece of mail addressed to him, and in turning it over to the editors, we quote the note he attached to the script: "It works. When I saw the idea and the sketch Eugene Amstus forwarded the Station the other day, I said it ought to make a good bunny-buster for that big jackrabbit that inhabits the neighboring Bar-Circle Bar-Circle Bar-Circle cabbage patch. He's been thumping around under the Exp. Sta. shack a lot these winter nights, and I aimed to get him. We built this

little gun according to Amstus' sketch and yesterday had rabbit stew. The thing is simple—just brass tubing thrown together with a soldering iron as the sketch shows. Run it. Great fun!"

As may be seen the barrel is of  $\frac{1}{2}$ " outside diameter brass. A  $\frac{3}{16}$ " bolt clamps in through a rabbit seat in the breech for ramming out refractory shot when jammed.

The BB tube will have to be hand picked, and ought to be hard brass, just big enough to swallow a BB without trouble or friction. You'll have to adjust this to the shot you are using, as BB shot is never definitely standard.

## COMPRESSED AIR PISTOL

The pump barrel and the tank or concussion reservoir for storing air, are of brass tube. Use stiff springs for the valves, and cover them with oily leather, pounding them to a seat.

Outside cover pattern and trigger frame are of sheet metal. The stock is of walnut screwed to an outlined butt made of  $\frac{3}{8}$ " by  $\frac{1}{16}$ " strap iron.

A BB is rammed down, eight or ten good strokes taken, and the gun can then be shot. Muzzle velocity is controlled by the number of pump strokes.

Shoot at a pine board to test the pistol. If a BB sticks in this board at 25 feet you have plenty of power for target shooting and for bringing down small game like Slide Rule's jackrabbit.

This will be found a practical and useful little weapon if carefully made. A relief valve can be fitted limiting its power for use in the hands of the youngsters.

## PARACHUTE PROJECTILE.

This toy comprises a sphere in two parts hinged together and containing a miniature parachute, trapeze with figure of a man attached. A string is fastened to one of the halves of the sphere and wound

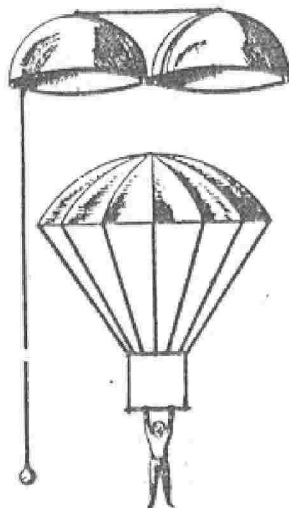

Parachute Bomb.

about it several times. The other end of the string is fastened to a small weight. The sphere is fired from a mortar, and when high in the air the string unwinds, allowing the ball to open and release the contents.

## NIGHT VOLCANO IN OPERATION.

Take ordinary black powder, place it in a dish (must not be a metal one) and pour in just enough turpentine to form a dough when it is mixed. A soft pine stick of clean, new lumber free from grit, or a green branch should be used to stir the mass gently. When mixed take about as much of the powder as will fill a teacup and with the hands compress it and mould to a point at the top, the sides sloping about equally all around. In the top insert some dry twisted paper extending about two inches above the volcano. Cover the outside of the mountain with a coating of damp stiff clay (not mud) leaving an opening one-half inch across for the crater. Through this the paper extends. Light the paper with a torch and the result is a shower of beautiful sparks playing like a fountain. A volcano four inches high should burn one minute or more. It is best displayed at night, although it makes an interesting day piece.

## Knock-Down Target Is Replaced From Shooting Position

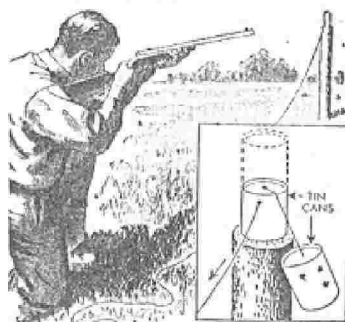

You can knock this target over and then pull it back in place without so much as moving from your shooting position. Two tin cans are required for this setup, one for the target and one for the base. Holes are punched in the end and side of the base, which is attached to the post. Then a cord is fastened to the bottom of the can used for the target and run through the end and side of the base. Whenever the target is knocked off the base, it is returned to its original position by pulling on the string. When setting up the target, be sure there is a suitable backstop for the bullet or other missile that is fired.

# ELECTRIC Cannon Uses No Gunpowder

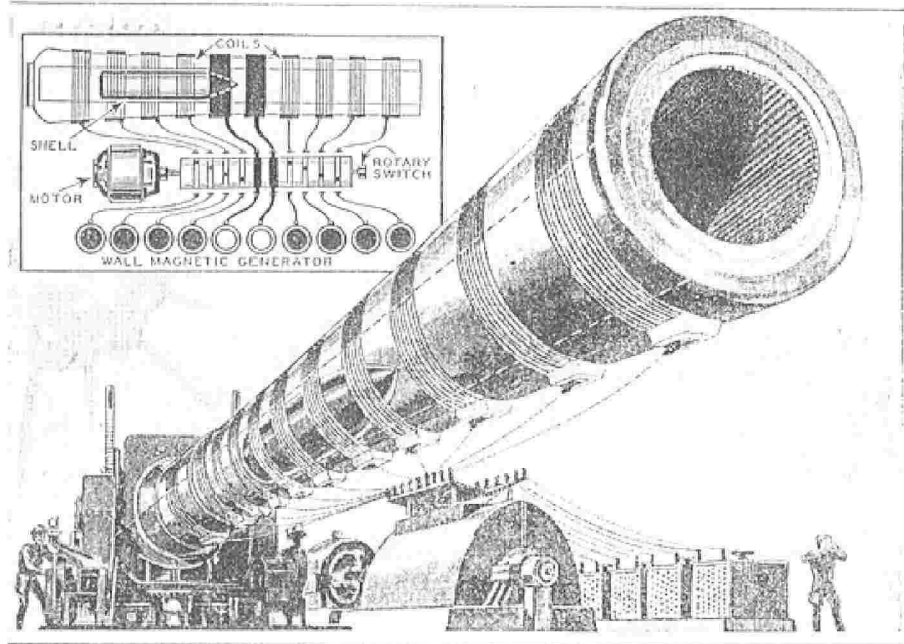

The magnetic gun, pictured on this month's cover, is foreshadowed by achievements of two English experimenters. Powerful currents working through coils around the gun barrel exert a magnetic effect on the steel shell, pulling it through the barrel at tremendous speed. Each coil has its own generator, and the shell advancing through the barrel will automatically energize the coil just ahead of it. A rotary switch could be employed to adapt the idea to machine guns.

*Modern Mechanix June 1932*

**SILENT** guns sending their whistling messengers of death into the sky at speeds far beyond those now attained by powder-driven shells seem likely for the next war, using for propulsion magnetic fields so powerful that when they are short-circuited they produce miniature earthquakes.

Dr. Kapitza, F. R. S., working at the Cavendish Laboratory of Cambridge University, England, in his attempts to disrupt the atom has produced magnetic fields so powerful that they "explode" the coils that produce them. This man has finally revealed the secret of the magnetic gun so long anticipated by ballistic experts. Dr. Kapitza accomplishes the electric firing of a shell by short-circuiting powerful dynamos for periods of one one-hundredth of a second.

Another English experimenter, Dr. Wall, seeking the same thing, produces ultra-magnetic fields with a more simple apparatus. Dr. Wall simply charges electrostatic condensers and permits them to discharge their powerful currents into specially made coils immersed in oil baths. Here also magnetic fields so powerful that they tear the coils to pieces have been produced. So great are these magnetic fields that they are capable of pulling iron nails out of shoes.

While the magnetic effects produced by

both of these experimenters are of very short duration, they could be employed to impart their terrible energy to steel shells. The time limit, which cannot exceed one one-hundredth of a second, is imposed because of the powerful currents used. If these currents were permitted to flow through wire for a greater period of time, the wire would melt and temperatures greater than those existing in some of the hottest stars would be produced.

To produce a magnetic gun—a silent Big-Bertha—it will only be necessary to arrange a series of powerful coils within the gun barrel. Each coil will have its own generator and the shell advancing through the barrel will automatically energize the coil just ahead of it. By the time the shell reaches the end of the barrel it will have attained a speed far in excess of the speeds now attainable with even the highest explosives known.

Owing to the entire absence of internal pressures these guns may be made of ordinary iron or even of purely non-magnetic materials. The "magnetic explosions" will be initiated by the simple closing of a switch which will energize the first coil and snatch the shell from the breech in the first leg of its journey of destruction.



## THE FOUR WINDS SHOTGUN

by Kurt Saxon

This is the simplest, safest, cheapest 12 gauge shotgun ever devised. It was used in the Philippines against the Japanese and was known as the "Slam-Bang." Anyone can get the parts and make it in a couple of hours.

If used outside the home it can be disassembled in seconds, its parts thrown in every direction, hence the name, "Four Winds." It can be fired several times a minute and has a moderate kick. Loaded, it weighs about 2 1/4 pounds. Basic cost, under \$5.00.

It is made of common, galvanized plumbing pipe, bought from any large hardware store, plumbing supply or even junk yard. To make it you need a 1 inch cap, 6 inches of 1 inch pipe, threaded on one end and 10 inches of 3/4 inch pipe. Then you need a 1 inch dowel, a No. 16 nail, a 1 1/8 inch circle of thin cardboard and some duct tape.

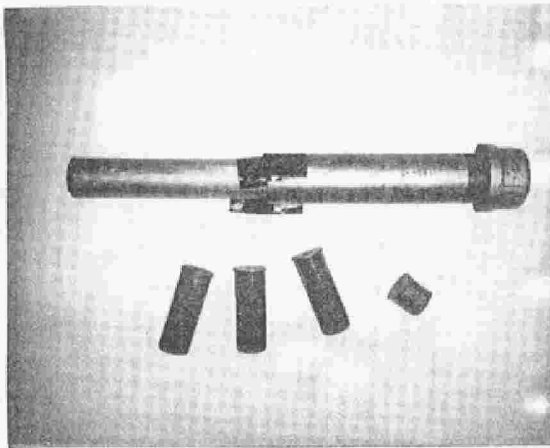

Gun with safety tape. Shells. Primer section.

Tools and various items you need are a metal cutting hacksaw, a sheet of coarse emery cloth, and some Super-Glu Gel, all gotten at any hardware store, cheaply.

First buy a foot of 3/4 inch pipe. If you buy only a foot you should cut the two extra inches off, yourself. It takes only about five minutes per cut. Having them cut costs 75¢ per cut.

1 inch dowel

Thin cardboard

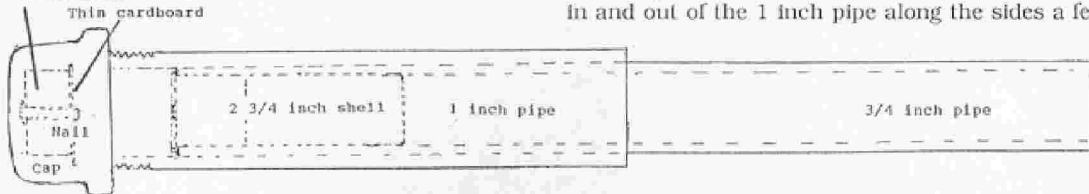

Then buy 6 inches of 1 inch pipe. If it is scrap pipe it may already be threaded. If not, have them thread it, but only at one end. Then buy a 1 inch pipe cap.

There's no reason anyone should suspect you of anything, even if you buy everything at one hardware store, although you might buy the 3/4 inch pipe at another store. But if you should buy even four feet of 3/4 inch pipe, four caps and have four 6 inch lengths of 1 inch pipe cut and threaded and the clerk should ask what it was for, you might tell him your brother-in-law is making some sort of metal table.

If the pipes are cut for you, make sure they are reamed at the cuts. Otherwise there will be a heavy lip at the cut, which doesn't happen when cut with a hacksaw. You can get this lip off with a rounded file or just cut 1/16 off with your hacksaw. You don't want a deep ream at the shell end. The 12 gauge lip should rest on the natural lip of the 3/4 inch pipe. Otherwise it might sink into the reamed portion and be a little harder to get out after being fired.

When you have the two pipes of proper lengths, insert the 3/4 into the 1 inch pipe. It will probably stick. You want it to slide through every time with no sticking or slowing. For this you need to make your own reamer.

Cut 7 or 8 inches from your 1 inch dowel. Then cut a piece 5 x 3 1/16 inches from the sheet of emery cloth.

The 1 inch dowel I bought was actually 15/16 of an inch thick and my 1 inch pipe had an inside diameter of 1 1/16 inches. When you buy your dowel take the 6 inch pipe and make sure the dowel goes in with some space to spare. If the dowel fits exactly, it's too big and you'll have to choose the next size down.

Regardless, wrap the emery cloth around the dowel and mark it where it meets. Then cut off about 5 inches. Next, take the Super-Glu Gel and quickly squeeze a line down the length of the emery cloth. Quickly put the emery cloth along one end of the dowel and press evenly. Use gloves, as any glue on the fingers will make them stick. After about 30 seconds the cloth will be stuck tight and you can wrap it around until it meets. Then quickly squeeze another line of glue down the unglued side and press it up against the other side. You might quickly put several large rubber bands the length of the emery cloth to make it set evenly.

Now you have a reamer without peer. Just rub it in and out of the 1 inch pipe along the sides a few

times to get rid of any burrs or uneven areas. Try the 3/4 pipe and if it won't fall through without slowing, do it again until you have it fail-safe.

If the fault is with the 3/4 inch pipe, a few good rubs with the emery cloth on the dowel on any outside protruberances will even it off.

When it's done its job the reamer makes a dandy knife sharpener. Put it in your kitchen drawer. A couple of swipes down each side of the blade will keep your kitchen knives as good as new.

When you have the 1 inch pipe properly reamed, you make the hammer. First cut a half inch piece of the dowel. Choose a drill the same width as the No. 16 nail and drill a hole through the exact center of the dowel piece.

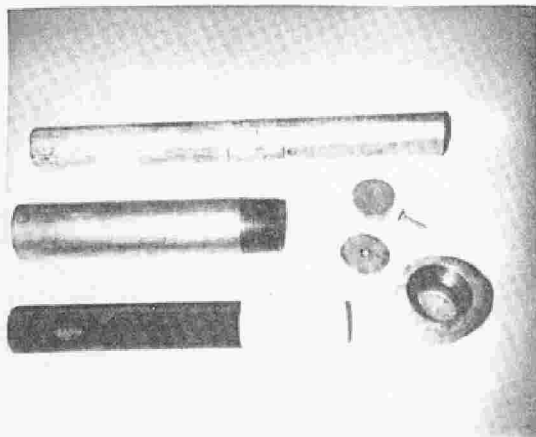

3/4 inch pipe, 1 inch pipe, Reamer, 1 inch dowel, hammer, Cardboard, Cap.

With your hacksaw, cut the nail 5/8 of an inch past the head. Then cut a 1 1/8 inch wide circle of thin cardboard and with the nail point, punch a hole in its middle. Push the nail section through the dowel hole and push the cardboard over its end with the rough side on top. Then push the hammer unit into the cap, cardboard side up. The cardboard is to keep the dowel and hammer in the cap. When you've fired it, if you feel the need to disassemble, just pick the unit out by the nail with your fingernails and flick it away.

Screw the cap on, put a 12 gauge shell in the 3/4 inch pipe, put the 3/4 inch pipe in the 1 inch pipe and it's ready to fire. Well, not quite ready, maybe. If you load it in your car and put it under your seat or load it in your home and put it near the door, fine. But if you're going to carry it around before using it, you need to make it fail-safe.

First, cut a piece of Scotch Tape a little over 1 1/2 inches down the middle. Take one half and put it across the middle of the shell over the primer and down both sides of the pipe. This will keep the shell

from sliding out of the pipe when it's pulled out preparatory to firing.

Next you have to make sure it doesn't go off if you drop it. To make it fail-safe for a klutz, cut four inches of duct tape. Then fold one inch onto the tape to make a finger hold. Next, pull out the 3/4 inch pipe so the gun is 12 inches long. Then put the tape over where the two pipes meet and press it down firmly. This doesn't go all around but it doesn't need to. I held it 6 feet off the floor and dropped it and it held. When ready to fire, just grasp the folded over section and pull it off. Less than a second.

I'll bet while reading this you've been worrying about testing the gun. And testing is critical. You should never make a weapon and expect to test it when the time comes. Anyhow, testing this, or any other improvised firearm can be done safely and simply.

You just cut through the shell, past the metal part with your hacksaw. Then pick out the wadding over the powder and pour it out. Next you put the primer part in the 3/4 inch pipe and put that in the 1 inch pipe. Then rest its mouth on a pillow and slam it home. There will be a pop that may be heard across the room, but not through the walls.

If it's a regular bullet you're making a test with, just pull out the bullet and pour out the powder. There's no need for noise or danger.

So here's a weapon, handy, concealable, devastating. In the event that you should use it in a semi-public place and might be caught with it, get rid of it immediately after firing. First take out the 3/4 inch pipe, strip off the Scotch tape and throw the pipe and shell in opposite directions. Then unscrew the cap and toss the 6 inch pipe. Now pick out the hammer unit and throw it and the cap in opposite directions. Follow this drill a few times and you can do it in five seconds. Then go on about your business.

If you should be found at the scene after you've disposed of the weapon, just say it was a drive-by shooting. There is no possibility that anyone would look for, find, or connect the loose parts to any shooting. There are no ballistics or powder residue on the hands, as with a revolver. If used to defend your home, the disassembled parts spread around your home would not be noted. No weapon, no charge.

Just in case you recently came here from the moon, ownership of this weapon is illegal. But having the various components spread around your home, ready to be put together when the time comes, is not actionable. Also, it's better to be judged by 12 than carried by 6.

When choosing a box of shotgun shells at a gun show, sporting goods store or Wal-Mart, you have a choice of several lengths of shell and loads. The most



common is 2 3/4 inches long. Common lethal buckshot loads are: 00= .32 caliber, 9 in the 2 3/4 inch, 15 in the 3 inch, and 18 in the 3 1/2 inch. Buckshot 0= .30 caliber, 12 in the 2 3/4 inch. For the No. 1 buckshot, which I think has .22 caliber pellets is 16 in the 2 3/4 inch.

I would choose the 2 3/4 inch shell with 12 .30 caliber pellets, but any of the above would be fantastic. This is a close-up weapon, but then again, has a hell of a spread, due to the shortness of the barrel. One shot toward several opponents would be better than any semi-automatic.

## A "POTASH VOLCANO"

How you can make it:

*Popular Mechanics, June 1902*



Shooting forth flames and spouting ashes and lava the "Potash Volcano," is a miniature likeness of the great Mont Pelee eruption that destroyed St. Pierre. Any child can make a "Potash Volcano," and it is not more dangerous than firing a firecracker. It is the only toy volcano that will emit lava which flows down its side in realistic streams.

To make the volcano build a mound of sand about one foot high. Dig a hole in the top 5 inches deep and 1-1/2 inches in diameter. Roll up a piece of stiff paper to form a cylinder and place it in the hole making the paper form the wall of the hole. Also place a piece of stiff paper at the bottom of the hole. Make the paper hide the ground in all parts of the hole so as to keep away the moisture of the ground. Now your volcano is built. The next is to load it.

You are supposed to have at your side 10¢ worth of potash, which may be bought at any drug store. Be sure to tell the druggist the purpose for which it is wanted as there are numerous kinds of potash that will not do (if potash is unavailable try saltpeter). Mix your potash with an equal amount of sugar. Now it is ready to be put into the hole. But first arrange the fuse by which the volcano is to be lighted. For this a fire cracker stem will do, but you may make a better fuse yourself by winding powder in tissue paper. Place one end of the fuse down in the hole leaving the other end resting on the side of the volcano. Now place the mixture of potash and sugar in the hole. On top of this place a layer of pure potash unmixed with the sugar, and on this pour some gun powder. Light the fuse and the volcano will do the rest. There is an explosion which sends fire, smoke and sand upward. Then follows a flame lasting for about a minute and the lava pours down the sides of the mound.

*Popular Mechanics March 15, 1902*

**WORLD IS GOING CRAZY, SAYS DR. HOYT.**

**Present Rate of Insanity and Criminality Gives Cause for Alarm.**

Dr. Benjamin R. Hoyt of Detroit has figured out that the

world will be mad within three centuries at the present rate of increase of insanity. He says:

"During the past fifty years the number of insane persons and fools has increased 300 per cent. During the last decade the increase of population has been 30 per cent, and the apparent increase in the defective classes has been a little more than 155 per cent.

"The United States census of 1890 showed the total number of persons in prisons to be 82,329; number in juvenile reformatories, 14,846; number in almshouses, 73,045; inmates of benevolent institutions, 111,900; number of insane, 106,445. Total number belonging to defective classes, 403,615.

"In 1850 one person in every 3,500 was a criminal. In 1890 there was one criminal for every 786 of population, an increase of 445 per cent, while the population increased only 170 per cent.

"We are rushing toward an abyss that will engulf the world unless something is done to check immorality and neglect of the laws of nature."

### Mercury Fulminate

1. 100 grains of Mercury is dissolved in 1 1/2 drams of Nitric Acid (1.3 specific gravity) and allowed to sit for 30 min after dissolving
2. Solution is cooled and added to 2 oz of alcohol (.849 sp grav) in a glass vessel. A little heat is applied until effervescence is started - do not apply more than is needed, Allow the reaction to continue to completion
3. Cool the reacted product, filter out the crystals that form and wash at once with water and allow to dry at room temp or in the shade in sunner.
- 10 NOT allow these crystals to get any more than warm, and keep away from everything & everyone.

Fumes produced in the reaction are very toxic and flammable.

This process should produce a product that is slightly gray with a possible yellow tint in a crystal form. These crystals may be crushed while wet if need be but VERY CAREFULLY and slowly - with no impact.

Product is best if mixed with 20% Potassium Chlorate to produce more heat on detonation and as such becomes a better cap to set off some of the harder main explosives with more authority. This mix can be pressed into the container at approx 2-3,000 psi. A standard fuse will make this go as well as a hot wire, but it also seemd to be more stable when made up in this manner. A 308 rifle casing worked very well when ever it was tested even on the "Difficult List types".

## Electric Pistol Fired by a Small Dry Battery



Electric firearms may displace the present-day rifle and revolver just as they outmoded the old flintlock gun. Dr. G. W. Thiessen of Monmouth college has developed a target pistol whose .22-caliber bullet is fired by a four and one-half volt radio battery. Hammers, extractors, ejectors and the metallic and paper casings now used for shells are eliminated. Instead, cartridges which burn completely are used, and Dr. Thiessen believes gunpowder will be supplanted by a better explosive, perhaps liquid. His first model employed the jump-spark principle requiring a coil and miniature spark plug, but this method was discarded in favor of a "hot wire" to fire the charge at the trigger pull.

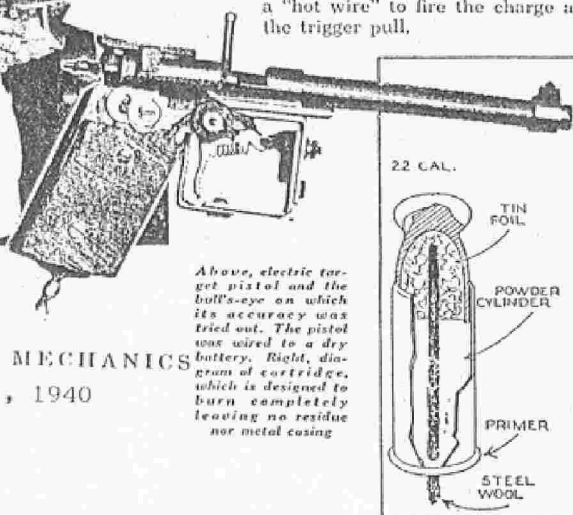

Above, electric target pistol and the bull's-eye on which its accuracy was tried out. The pistol was wired to a dry battery. Right, diagram of cartridge, which is designed to burn completely leaving no residue nor metal casing

POPULAR MECHANICS

August, 1940

Modern Mechanix January, 1934

### Soldering Block Resists Heat and Acid

**I**DEAL for soldering is this little plaster of Paris block which keeps your workbench free from acid burns and charred spots. Consulting the drawing at the right, you will see how the trick is turned.

A frame of wood, not very deep, is filled with plaster of Paris, with which salt has been mixed for quick drying. On this block you can solder any job that turns up, and the acid won't have the slightest effect. Likewise with the heat of the iron.—James Flug.

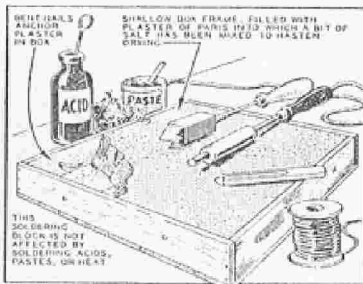



## THE ROMAN G.I.

THE COMPACT, CONTROLLED, MEAN WORLD OF HISTORY'S  
MOST EFFECTIVE COMBAT SOLDIER BY JAMES R. SILKE

If any combat soldier was 'government issue', it was the Roman legionary. He fought, marched, bled and died on command. He conformed to the military mold for twenty-five years of his life and did so for a good reason. He was the best. The Roman legionary literally didn't need good officers. He fought in essentially the same way for over three hundred years. He could make the weakest of the emperor's favorites look good as an officer and just how he did it is one of the most fascinating explorations in combat history.

In the year One A.D., war was a close, mean, desperate, slow and painful hand-to-hand struggle. Defeat or victory, life and death, were

measured in seconds and inches. The legates (generals) and their staffs of tribunes (officers) were all born to wealth and command. War, for them, was a temporary and often quick means to a successful political or financial future. The officers measured war in loose terms of borders, provinces and prestige, but for the Roman G.I., it was far more precise. The legionary wanted the enemy close enough to destroy, but not so close that he would slip in his sweat or be momentarily blinded by his spurning blood. An inch or a second literally made the difference between the welcome jar of a bone crushing, life ending, sword thrust and the flashing pain of the legion-

ary's first and fatal mistake. While the legates and tribunes rode on proud chargers over the world they ruled, few ignored the fact that the legionary made it possible. The maps of England, Gaul, Spain, Africa, Greece, Egypt, Judea and the Near East were remade by the men who marched rather than rode. The great Roman military ge-

### RANK AND PAY CHART

(Early Empire)  
(yearly wages)

#### CENTURIONS

Primus Pilus, senior centurion of the First Cohort	15,000 denarii	\$1,200
Primi Ordines, centurions of the first cohort	7,500 denarii	600
Ordines, centurions of cohorts two through ten	3,750 denarii	300

All centurions were further graded as HASTATI (youngest), PRINCIPES (junior) and PILANI (senior or oldest) centurions.

#### OPTIONS

Understudies of the centurions. Apparently there was one for each centurion. Their pay is estimated at 1,800 denarii, but ranged widely from cohort one through ten and from job to job.

#### LEGIONAIRES

Praetorian, honor guard of the emperor stationed in Rome	750 denarii	60
Members of the First Cohort	450 denarii	36
Members of Cohorts two through ten	225 denarii	18

#### ADDITIONAL BENEFITS

Augustus gave his legions gratuities of 2,500, 500 and 250 denarii on separate occasions. Other emperors gave similar amounts.

On discharge each veteran received 12,000 denarii and in many cases a plot of land.

#### DEDUCTIONS

Compulsory loans of one half of all gratuities and pay were taken by the state to pay for bedding, boot and strap, the annual camp dinner and, most important, food and the burial society.

niuses, Marius, Julius Caesar, Pompey and Caesar Augustus, shaped and reshaped their military tactics and organizations to support and sustain the men who risked their lives in the narrow, fragile limitations of combat.

### THE LEGION

The Republic of Rome was founded in 509 BC and the army during that time was formed into legions with the tactical unit being the maniple of approximately 120 men. The maniple, however, was both too small and too large. Too small to withstand barbaric hordes

which infiltrated the gaps between the maniples and too large for one man to properly command. The legion was reorganized, probably under Marius in approximately 112 BC, into a cohort structure of 600 men. The cohort was made up of six centuries for smaller tactical operations and for the sake of efficient command. For administrative details, the maniple, now of two centuries, was maintained, but the century was the essential combat unit. Much like the platoon of today, its strength varied from the 100, for which it was named, to around 60. This size unit has proved to be the most effective combat strength for various successful armies throughout history. One man can command it with maximum effect if he is able. The Roman generals after Marius all put their personal and national ambitions into the hands of the men who commanded the centuries. From the beginning of the Empire in 27 BC up the closing years in 395 AD those centurions led the Roman Legions and formed their own distinct structure for a truly G.I. army.

**ORGANIZATION**

The Roman Army was essentially a non-commissioned organization. It's strength, its tactics, and its pride began with the **Primus Pilus**, the number one centurion of the First Cohort of each legion, and moved down to the raw recruits, the seventeen year old boys just beginning the first year of their twenty-five year hitch. This fact was so imbedded in the military system and the military system was so much a part of Roman life, that in time the Emperors would come from the ranks of the centurions.

Each legion carried with it an Eagle (Aquila) and the **Primus Pilus** carried the eagle or had his understudy, an Aquilifer, carry it. The Aquilifer came from the **Optiones**, the rank just below the centurions. The Eagle itself was more than a symbol. A religious cult, the 'numen legionis' was built around it. Every Roman G.I. believed in it and knew that the loss of the Eagle

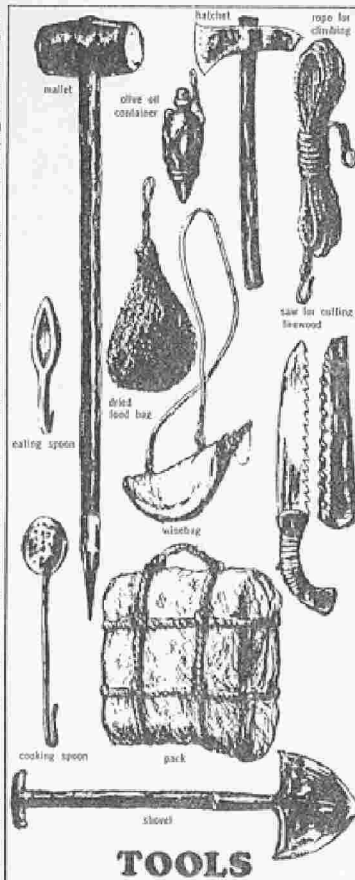

**TOOLS**

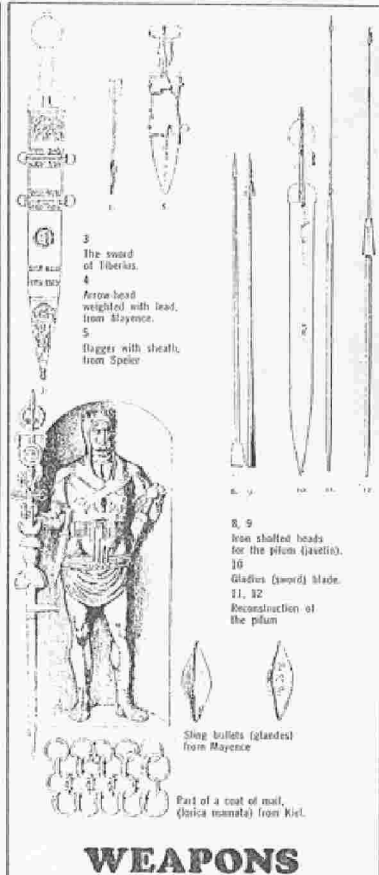

**WEAPONS**

meant the loss of the legion. For the legion to continue, for their lives to continue, the Eagle must be sustained, protected. Loss meant banishment and sometimes death by the hands of comrades in other legions.

The ideal manpower of a legion and the varying ranks and pay of the non-commissioned officers who commanded them is shown in the accompanying chart. A century, however, often didn't have its full complement of men, and, just as the strength of an army platoon in Vietnam will change in combat on a minute by minute basis, so did the century change during combat.

The Roman Army organization presented opportunity for advancement to the G.I.s who wanted and

sought it. The **Primus Pilus** was equivalent to a U.S. Army Major. He was responsible for the tactics of the legion in combat and its conduct in camp or on the march. The organization made it possible for the best men to reach that rank in as few as nine promotions. And, he reached it because of experience and success in military combat. For the 'ranker,' and most Roman G.I.s were that, it took as many as fifty-nine promotions to move to the rank of **Primus Pilus** and most never made it. Promotions were made from Cohort to Cohort and the quality of the centurions and the men got better and better moving from Cohort Ten to Cohort One.

The Roman always knew where

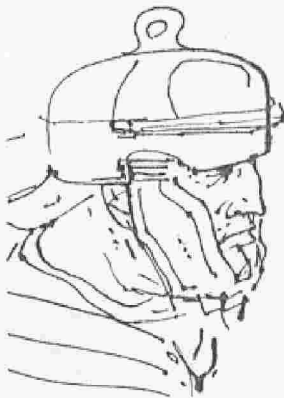

## HELMETS

the best men were and designed their method of attack to take advantage of them.

### TACTICS

The Romans took the close, mean, desperate, style of warfare of their time and made it closer, meaner and gave the desperation method and precision. And, they did it expertly. For over three hundred

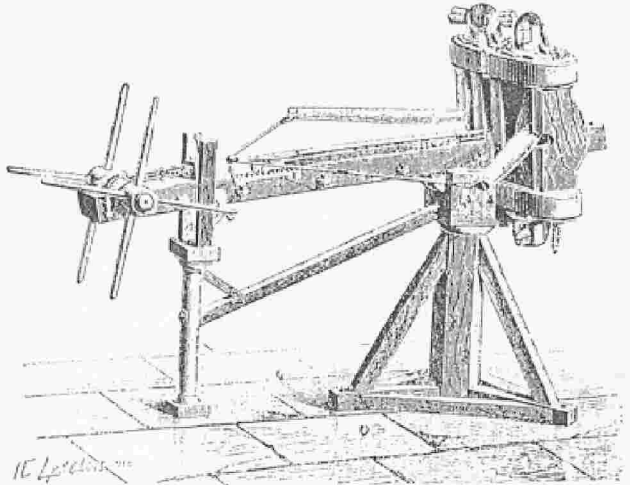

A smaller catapulta in the museum of Besancon. The Romans possessed the art of making rope skeins of hair and gut which, when wound tight and suddenly released, threw the stones and javelins upwards of 600 yards. The art was lost and Medieval warriors used a counter-posed weight system with half the range.

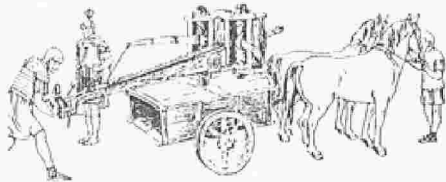

The catapulta, here on wheels and horse drawn, threw a large heavy spear.

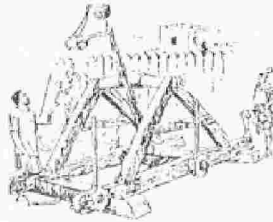

The Onager threw large stones.

## HEAVY WEAPONS

years there wasn't much of a contest. Roman G.I.s moved like tight ends or pulling guards on a professional football team. They were big, rough, quick, sometimes awkward, explosive and, when required, slow and painful. They moved into and over the enemy, not around it, and they came in waves or platoons. It was like the Green Bay Packers against East Tulare High.

Meticulous attention was given to each detail . . . to the seconds and inches. The pattern of attack was fixed and remained for three centuries. Little was left to chance.

The Roman G.I. was equipped like a small fort. He was part of a unit of one hundred that was designed to fight like a single individual and they were, in fact, actually linked together on occasion

**ORGANIZATION OF THE LEGION**

**LEGION**; consisted of 6000 men when at capacity strength, but ranged in actual strength from 3,000 to 6,000.

**COHORT**; there were ten cohorts to a legion with each consisting of 600 men. The quality of men ranged from cohort one (the best and most experienced) to cohort ten (raw recruits). In combat, the cohort was drawn up in centuries two deep and three across. Centurions were designated prior (front) and posterior (rear).

**MANIPLE**; there were three maniples to each cohort and each contained 200 men. The maniple under the early empire was strictly an administrative division and had no tactical purpose.

**CENTURY**; there were 60 centuries to a legion, 6 to every cohort and 2 to every maniple. Each consisted of 100 men.

**ANTESIGNANI**; a picked squad, lightly equipped, which was chosen by the Primus Pilus from the front line of the first cohort for scouting duty.

**CAVALRY**; there were 120 horse soldiers to every legion which were used primarily for scouting and dispatches. As a cavalryman had to supply his own horse, the horse soldiers came from the ranks of the Roman knights, the social and economic order just below the senatorial class.

**AUXILIARY**; the Roman policy was to draw supernumerary troops from the native peoples they conquered. The strength of the auxiliaries attached to each legion varied with its duties, locales and needs. Caesar had with him Baleric slingers, Cretan archers and Numidians. Note; slingers and stone throwers were almost invariably left handed as the Roman had little use for southpaws.

distance of 360 feet was selected after careful experimenting as to just what distance allowed the legionary to attack at his most effective condition.

Due to the weight he carried and due to the fact that he fought as hard as he could every moment in combat, the peak effective length of combat time was measured at fifteen minutes. All combat tactics were based on that fact. The six centuries of each cohort came in six waves of between sixty and one hundred men. Each wave fought fifteen minutes and rested for seventy-five. Almost daily practice was given to making the maneuver of replacing an entire century in the middle of combat. With fresh troops arriving every fifteen minutes, the pressure could be kept on the enemy for a total of ten and one half

hours. It was more than enough.

When the correct distance of 360 feet was reached, the front rank Cohorts (1, 2, 3, and 4; see illustration) moved quickly forward to within 200 feet. At that point, the first two rows ran at the front rank of the enemy with their javelins (pilum) in throwing position. Just before closing with the enemy, they threw their javelins at the front rank, drew their short swords and hit hard, jabbing and hacking.

As the front rows hit the enemy, the next three rows had moved up and were hurling their javelins at the rear of the enemy to create confusion and to make it difficult and dangerous for them to bring up reserves. These three rows then immediately hit the front rank of the enemy choosing either to support their comrades in trouble or add-

**THE G.I.**

by their shields. But the Roman G.I. was also designed individually. Weight, speed, protection and striking power were the primary factors in his design. The illustrations included here show just what he wore and what he looked like. It is obvious he carried in excess of eighty pounds into combat and, naturally, he tired quickly.

The Romans were a patient, a stable people. They could wait for the right conditions and did. Avoiding the danger of fatiguing their men, the Primus Pilus only gave the order to attack at precisely the correct moment. If the enemy was in a defensive position, the trumpets sounded when the front (prior) ranks were exactly 360 feet away. If the enemy was advancing, the attack signal was given when there was 750 feet between the front rank and the enemy. In both cases, the distance to be covered by the charging Roman G.I.s was the same. The



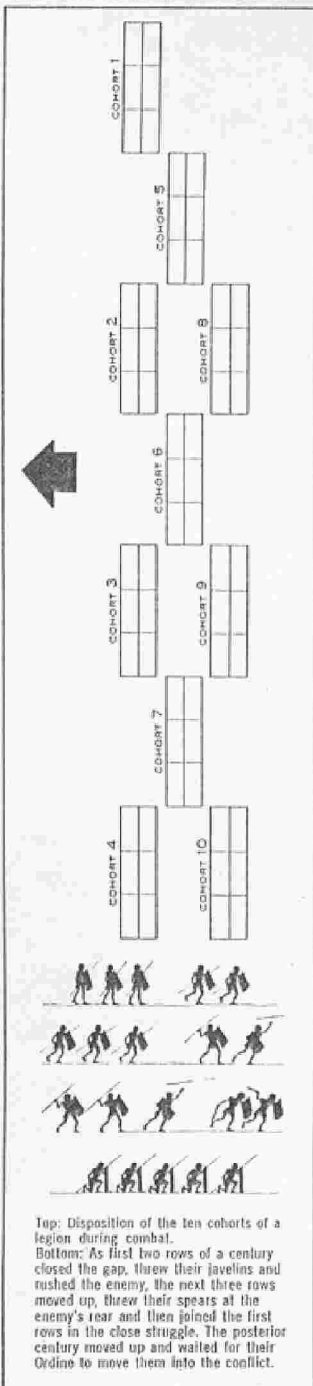

ing to the weight of impact where they were gaining an advantage.

Simultaneously the second rank (posterior) of Cohorts 1, 2, 3, and 4 advanced one-third of the distance to the enemy and took positions to cover emergencies and to take advantage of success.

If the first or second attack seemed to promise success, Cohorts 5, 6 and 7 rushed into combat hurling their javelins at the enemy's rear ranks and pressing hard into the weak areas. The remaining three Cohorts, 8, 9 and 10 were held in reserve, in case the enemy rallied or in case they were faking retreat and drawing the legion into a trap.

The Romans went about their warring systematically, carefully and in a manner that indicated they never had a hope, a thought, or a desire for it to end. For the G.I. serving twenty-five years, and in

many cases more, it simply never did end. It was his way of life, his children could follow and for the most part, did. Combat certainly brought the fear of death, but the legionary had other problems he often considered more important and many that were more constant.

## WEAPONS

Weapons were a primary concern. The G.I. had to supply his own on entering the service, but the opportunistic centurion no doubt made it possible for the raw recruit to obtain weapons at the standard unreasonable loan rate if a civilian speculator hadn't done so. Maintenance of the weapons, however, was a government responsibility and armourers were designated for each cohort. The offensive weapons consisted of a pilum



PRIMUS PILUS



or a lancea, both were throwing spears, javelins, with the *pilum* being the heavier of the two. The *gladius*, or Spanish short sword, was the principal weapon. Its short length is a clear indication of just how close the legionary got to the enemy before he was able to destroy him. The *pugio*, dagger, was more of a tool than a weapon, but was no doubt put to use by the G.I. when it served him to use it against the enemy. The *scutum*, shield, was also considered a weapon because of the manner in which the Romans attacked and its edges found their way into many a Celtic, German and Parthian ribcage and groin.

The *pilum* is of particular interest as it shows how the Romans slowly and carefully developed their weapons. Over a period of 100 years the *pilum's* construction changed from being made by simply driving the shank into the handle to having the shank driven into the handle and then attached by metal rivets. It further changed when one of the rivets was made of wood so that the handle of the *pilum* would break off after making impact with an enemy shield and make it impossible for the enemy to reuse the *pilum*. Yet another perfection was made at a later date. The metal beneath the point was left untempered so that the impact of the *pilum* on an enemy shield bent the iron and made it impossible for him to draw the spear from his shield and thus hampered his movement.

### BURIAL

Scholars often comment that the Romans had a great fear of being forgotten and built monuments, left inscriptions and fashioned gilded graves to perpetuate their memory. Most of these efforts, however, pertain to the wealthy Senatorial class, the officer class. The G.I., however, had the same feelings and beliefs as his leaders. The impulse to be remembered went far deeper than individual pride.

The one thing the Roman G.I. wanted most from the army, was a proper burial. He was guaranteed

that and a stoppage in his pay was automatically taken for the "soldier's burial club" (ad signa). These burial clubs were more than traveling mortuaries. They were a religious unit and in time became the political structures around which discharged legionaires gained civil control in the many provinces they settled for the empire.

The fear of not being buried was nearly five hundred years old by One A.D. It began with a strange and still obscure Etruscan belief that found its ritual in the family structure. The priests of the religion were the living male leaders of the Etruscan households. The religion was perpetuated by the worship of the deceased who were buried on the home plot. Improper burial, burial in other than the homeplot and improper worship of the dead caused the deceased to travel in torment through the 'shades,' a nether world no one has properly defined. The Etruscan influence pervaded the Roman religion and, with time and change, the worship of the dead male members of the household became the worship of the dead members of the tribe and eventually the dead citizens of Rome. Every aspect of Roman life, in fact, was built and developed with the idea of preserving what was, of maintaining the Roman order rather than planting the Roman order. Even the empire grew and spread with this idea. Wars were fought to protect the borders of Rome rather than to spread its influence much in the same spirit as the United States is at war in Vietnam.

For the Roman G.I., however, it was not a philosophy he understood, but a practice, a fear and a necessity.

### CULTS

In addition to the worship of Rome and the Pantheon Gods, the legionary indulged in and welcomed other religions and practices. It was a time when the wisest of men would examine the bloody entrails and bones of a freshly slaughtered bull in order to determine whether or not to make war, marry, buy a

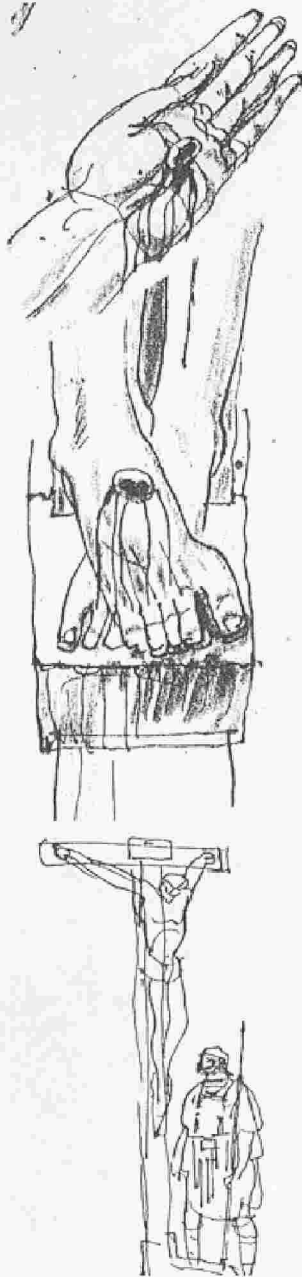

## EXECUTION

new slave or body lotion. Flights of birds were also studied in detail and intricate charts were made and examined to determine whether or not the Senale should meet. The G.I. adopted all the bastardized versions of such beliefs. His was a gutter religion and he practiced it with the same enthusiasm and diligence the China Marine gave to his gambling and liquor.

## WOMEN

Foreign lands and foreign women introduced most of the new beliefs and new practices to the men of the legions and provided the few creative comforts the Roman G.I. had. The legions were usually located in the same general geographic areas during the lifetime of a soldier and most eventually settled where they had served. The women, more available than attractive, found their way into the camps and forts and eventually into the beds and lives of the men. A legionary was a good catch, for, while he was not allowed to marry, the offspring of his illegal marriage were offered Roman citizenship upon enlisting in the army. Roman citizenship meant success in the Roman world and for the less ambitious woman, the fact that the G.I. got a salary, when 99% of the working class didn't, was enough inducement to make herself available. The option was slavery or starvation.

## SECURITY

In addition to the army offering a tomb and honorable burial, the G.I. was made secure in many other ways. Most of the legionnaires were, naturally, rankers, men designed by the gods to do little more than follow and survive. The army offered, as it does now, a relief from the responsibilities of existence. The pay was good, there was medical help available to cure with hot iron or emetics the humors that prowled the body after being stricken by a foul weapon or a fouler woman. Food was bought with stoppages in his pay and consisted of soup, bread, vegetables, lard, vinegar mixed with water, in the East olive

oil, and on occasion, wine. Beef was seldom found on a legionary's knife, but fowl and pork were his when he could catch it.

## DUTIES

During periods when there was no combat, and there were all too many for the G.I. bent on adventure and booty, the legions were set to building roads, aqueducts, cities, arenas and bridges. That many still stand testifies to how carefully they were built and to the philosophy of preserving and maintaining Rome rather than dominating the world.

Besides duty in combat, there were the normal, easy details; orderly room clerks and sergeants; the **Aquifers** who carried the Eagles in and out of combat; **Signifiers** who carried the emblems of the Maniples; **Optios** who took command when the centurion was gone; **Tesserarius** who received the watchword and trumpeteers, buglers, armourer-sergeants, doctors and vets, pickets, baggage details, those in charge of letting land to veterans of their century, and members of various tribunes' staffs.

## PUNISHMENT

If a legion, cohort or century deserted, mutinied or was insubordinate, it could be decimated (decimatio), which meant that every tenth man was beaten or stoned to death by his comrades. This seldom happened under the empire, but it indicates that the Roman G.I. was an integral part of a unit, if his partners failed, he failed, and every G.I. knew it.

## COMRADESHIP

Although it is not written down anywhere, perhaps the one aspect of Roman military life which was most vital was the relationship of each man for those on either side of him. Roman historians, all who came from the Senatorial class which was the only class taught how to read and write, only write of what the officers meant to each other. Anyone who ever went on patrol with other men, or played any kind of ball on a team, knows

how vital it is to have the best, the roughest, the toughest, the bravest of men on either flank. There was a man six feet to either side and one six feet to the rear of every Roman G.I. All were equipped with the best weapons, food, pay, fortifications, ordnance, transport, armor and tactics of their time. It is only logical that the men were also the best and if they weren't, were discarded long before a century of one hundred went into combat. It was better to go with ninety-nine, or for that matter sixty men, than to go with cowards. It was, in fact a necessity and it was inevitable that deep, strong relationships were made and kept.

Certainly corruption, stupid anger and pain were part of Roman camp life. The centurions, at least many of them, could be bought off and light duty obtained. As with all armies, the dreamers and the sensitive got the worst of it and a good woman, even a slightly reasonable woman, was fair game for your best friend. There was laughter, death, murder, good times and hatred in the camps of the legions. The camps were rich with the best and worst of life, but in the field of combat, only the best was acceptable. For the Roman G.I., anything less was not government issue.

## NEW GANGSTER WEAPON FITS PALM OF HAND

Popular Science Monthly  
— September 1935

A TINY but deadly automatic, recently found by Federal men in a thug's possession, bears witness to the ingenuity of gangland's inventors. Squeezing the gun in the

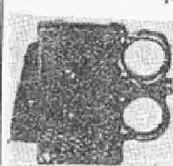

palm of the hand depresses a trigger bar, and the gun fires through a barrel between two finger loops. The weapon also serves the purpose of brass knuckles.

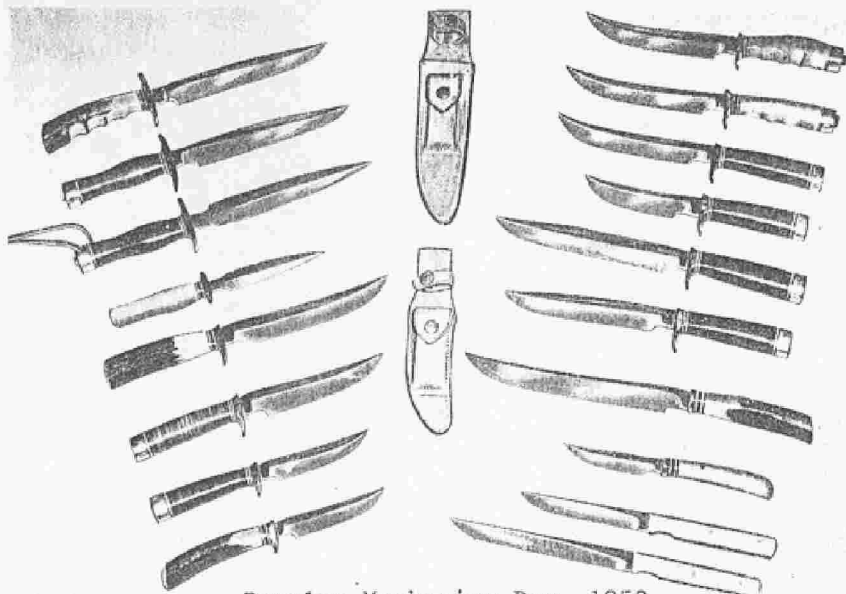

Popular Mechanics Dec. 1952

## Custom-Make Your HUNTING KNIFE

WHEN PREPARING for long and difficult trips afield, hunters, trappers and explorers often discard other less essential equipment in favor of the all-purpose hunting knife. An experienced camper alone in the woods would rather lose his tent than the hunting knife in his belt sheath. He can get along without the former; the latter is indispensable.

Although knifemiths usually select Swedish steels because of their stability and extremely fine grain, for the finest hand-forged custom blades, you can make a reasonably good hunting knife from a large mill file. Probably the next best material is an oil-hardening tool steel, as it has a better response to tempering and a more uniform soundness of structure than does the average file.

Photos on these pages showing the essential steps in knife making were taken in the workshop of W. D. Randall, noted knifemith who began making knives as a hobby and now is in the business of hand-forging them in various styles that class among the finest made. In the photo above Randall-made knives are shown in styles



Above, one of the first steps in making a knife is heating the blank in a blacksmith's forge. Below, after heating, the blank is hammer-forged on an anvil to draw the blade to the rough form for grinding

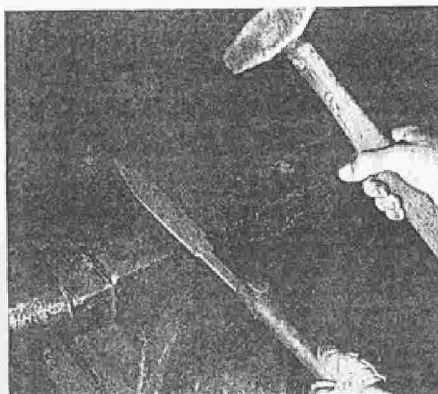





tempered the blade appears a straw-blue color and can be cut with a file. From this point on, special care must be used to avoid drawing the temper. True the bevels by slow, light grinding on a medium-fine wheel, checking the results continually by eye until all surfaces of the blade show a true reflection when viewed in oblique light. Before honing and buffing, the reflections will be rather dull, but they will enable you to spot irregularities in the surfaces. While grinding the blade to final contour, true up the tang and fit the hilt and butt piece. In the knives pictured and detailed, the hilt is of brass and the butt piece of aluminum. The hilt is filed to the rough shape before fitting to the tang. Final finishing of the blade is done on a hone as in the lower right-hand photo, and the fine scratches left by the final grinding are removed by buffing on a stitched buff as in the lower photo on the opposite page. The buff should be charged with polishing rouge of the type specified for steels.

Although ivory, staghorn and even certain metals are used for handles, ordinary top-grain cowhide is recommended for hunting knives. The lower center photo at the right compares the rough with the finished leather handle. Details below and on the opposite page give sizes of the leather disks. Note that the latter are oval in rough shape and that the center holes are cut rectangular to fit the tang snugly. Five 1/2-in. fiber squares in three colors are fitted on the tang next to the hilt. Then follow with the leather disks and three or five fiber squares. Cement each disk and square to the one preceding. Then attach the butt piece firmly in place by peening the tang projection. Rough to size and shape with a coarse rasp as in the upper center photo at the right. Then finish the hilt and the entire handle with a medium emery wheel and finally bring to a high polish with a stitched cloth buff charged with polishing rouge. When buffing be careful not to heat the leather handle unduly. The shape of the handle is optional. Grind it to a form that suits your finger grip. ★ ★ ★

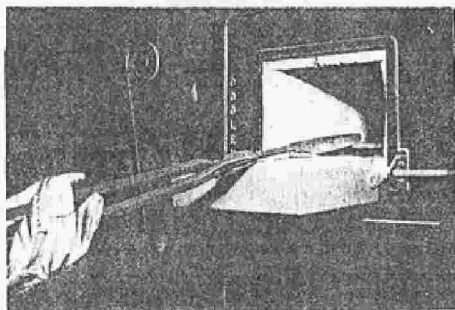

In the tempering process the blade is heated in an electric furnace which permits close control of temperatures so essential to proper tempering of steel

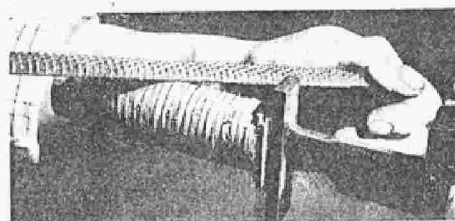

Leather handle is roughed out with a coarse rasp and the hilt and butt piece are filed to the rough shape. Finish with emery wheel and a stitched buff

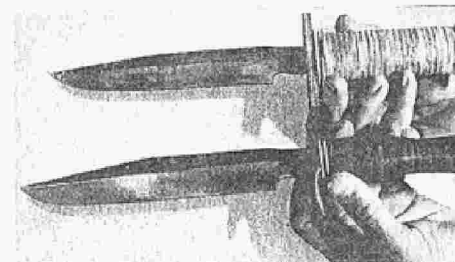

Above, the rough and finished handles of the all-purpose knife. Below, honing the blade by hand on a three-part professional-type hone. Note blade angle

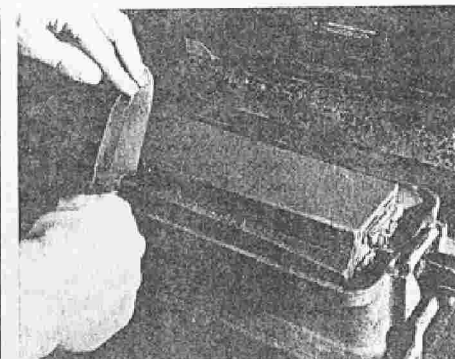
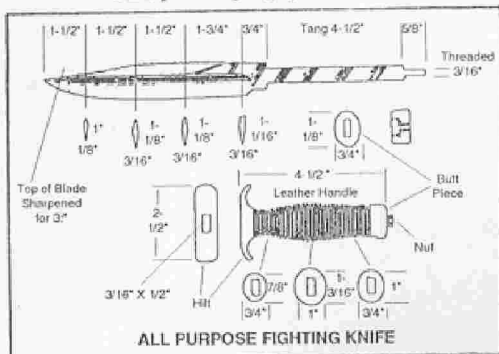

## Teach Soldiers to Shoot Straight

**This, the Problem of Most Vital Importance, Says Col. W. P. Hall**

This article is from Popular Mechanics, Feb., 1904. When you can shoot a rifle as well as our soldiers did during the Spanish-American war, your unit can defend its territory from any aggressor, especially if the aggressor is armed with modern semi-automatic weapons. Between the marksman and the "sprayer" there is simply no contest. So get your M1 30.06 Garand and practice to win.

By Col. W. P. Hall, Acting Adjutant General, U. S. A.

The future of the military establishment of our country seems to be very bright. The harbors which it is considered best to fortify against naval forces are rapidly being put in condition to make easy their successful defense. Our land forces, our regular army and militia are being trained on lines to make them quickly available for any emergency and to give them efficiency on the field of battle. The problem of the concentration of troops at certain points is, on account of the many railroad lines and other wonderful carrying capacity, quite a simple one, while the field maneuvers, practice marches and camps of instruction give the valuable lessons required for their disposition and handling in action and teaching the soldier how to shoot his arms and hit what he shoots at.

With the long range, high power military weapon now in use it becomes of more vital importance than ever before that the shooter should be a good marksman. If the all-round military efficiency be designated by ten points, at least eight of them are excellence in marksmanship.

In shooting a rifle at long range, if the shooter misses the object he intends to hit, the shot is generally lost and he is something like the quail shooter who fires at the flock when the covey gets up.

The value and importance of high efficiency in military rifle shooting on the field of battle was never so forcibly illustrated as during the Santiago campaign. For eighteen years previous to this our little army had received an excellent and thorough training in target practice and was as a class fine military rifle shots. They had been trained, with other things, to shoot at an object the size of a man's head and shoulders between five and six hundred yards, and many of them would hit, firing rapidly nine times out of ten.

At Santiago our troops marched over an open space from four to six hundred yards to attack an enemy in well constructed rifle pits upon the other side; our loss was comparatively small, and it is acknowledged that our opponents were very poor shots, and it is said they had received little or no training in rifle shooting.

In conversation with a number of our fine rifle shots who were in this campaign, I have gathered these facts, and one very sensible man remarked that if our men had been in the trenches they could easily have destroyed ten times their number of an attacking force. These remarks are not intended to and cannot cast a reflection upon any soldier opposed to us.

It is like a fine tennis or golf player engaging in a game with one who cannot play a little bit; the result is inevitable.

In conclusion, I will add that rifle shooting can be easily taught by proper training in the gallery and does not require a large expenditure of ammunition or much practice upon the range.

The responsibility of teaching soldiers how to shoot rests with the captains and lieutenants, and in order to teach it correctly they must know how to do it themselves.

I am glad to say that Congress is disposed to be liberal in appropriating for shooting galleries and ranges, and it is hoped our regular troops and militia and the various rifle and revolver clubs will soon be engaged in friendly shooting competitions all over the country.

In this way we will soon have an army ready to take the field on short notice, and their efficiency for effective work on the line of battle will be second to none.

---

A publisher has discovered that a bushel of wheat contains 869,720 grains.



BULL RUN.

## Southern Chivalry

Harpers Weekly, Feb. 7, 1863

In vindication of the picture illustrating Southern chivalry, we present below a few extracts from the history of the war. Jeff Davis, in his proclamations, has constantly endeavored to make it appear that whereas the war was waged with chivalry and gentleness by the South, it was carried on with every circumstance of atrocious savagery by the Union troops. Here are a few examples of the chivalry of which the rebel boasts.

### BARBARITIES AT MANASSAS

The Senate committee, appointed to inquire how the rebels had treated our

dead on the field of Manassas or Bull Run, say in their report:

The rebels manifested a fiendish spirit in their treatment of our dead. Bodies were pried out of their graves, and Mrs. Pierce Butler, who lives near the place, said that she had seen the rebels boiling portions of the bodies of our dead in order to obtain their bones as relics. They could not wait for them to decay. She said she had seen drumsticks made of Yankee shinbones, as they called them. She had seen a skull that one of the New Orleans Artillery had, which he said he was going to send home and have

mounted, and that he intended to drink brandy punch out of it the day he was married. Many of the bones had been manufactured into finger rings.

The outrages upon the dead will revive the recollections of the cruelties to which savage tribes subjected their prisoners. They were buried, in many cases, naked, with their faces downward. They were left to decay in the open air, their bones being carried off as trophies, sometimes, as the testimony proves, to be used as personal adornments; and one witness deliberately avers that the head of one of our most gallant officers was cut off by a secessionist, to be turned into a drinking-cup on the occasion of his marriage. Monstrous as this revelation may appear to be, your committee has been informed that during the last two weeks the skull of a Union soldier has been exhibited in the office of the Sergeant-at-Arms of the House of Representatives, which had been converted to such a purpose, and which had been found on the person of one of the rebel prisoners taken in a recent conflict. The testimony of Governor Sprague, of Rhode Island, is most interesting. It confirms the worst reports against the rebel soldiers, and conclusively proves that the body of one of the bravest officers in the volunteer service was burned. He does not hesitate to add that the hyena desecration of the burned corpse was because the rebels believed it to be the body of Colonel Slocum, against whom they were infuriated for having displayed so much courage and chivalry in forcing his regiment fearlessly and bravely upon them.

### HORRIBLE TREATMENT OF THE WOUNDED

A dispatch from Murfreesboro, dated December 31, says:

The enemy during yesterday harassed our rear with their cavalry, and captured some of our wounded men near Nolinsville. Rebel guerrilla bands attacked and burned our army wagons, ambulances, etc., and acted most out ragoonously, throwing the sick and wounded into the roads to die.

Major Slenner and Captain King, who were being conveyed away wounded from the battle field in an ambulance, were captured by the rebels, taken four miles away, and then paroled and thrown out on the road.

The Medical Director of General Grant's army, in an official report dated at Holly Springs on 30th December, says:

I received the assurance by Gen-

eral Ban Dorn's Adjutant that the Armory Hospital should not be burned, but that it should be protected by a guard. Satisfied with this, I returned to my quarters, but had not been there an hour when I was informed that the building was in flames; and thus this fine structure, with two thousand bunks, an immense lot of drugs and surgical apparatus, thousands of blankets, sheets, and bedsacks, was soon in ashes.

This proceeding, in violation of an express promise, and of all rules of civilized warfare, is an evidence of the barbarity and want of principle in the Confederate officers. But this was not all. An attempt was made to destroy the General Hospital, located on the main square, and which at the time contained over 500 sick.

A quantity of ordnance stores had been deposited in a building on the next block to the hospital, and by the order of General Van Dorn, as stated by the officer who had charge of the matter, the barrels of powder and boxes containing shell and cartridges were taken out and piled up nearly in front of the hospital and set fire to.

Two medical officers protested against this wanton act, but their requests were treated with contempt, and before there was time to remove the sick the walls and windows of the hospital were riddled with flying balls and shell, and finally a terrific explosion took place which shook the entire building, destroying almost every window and door in the establishment, wounding about twenty men, and creating a scene of the wildest confusion.

A large number of buildings on the public square took fire from the explosion, and it was only by the utmost efforts that the hospital was preserved as a shelter for the men in the night air.

Together with the medical officers who assisted me in caring for the sick and wounded on that trying day, I thought that the rebels had now done us all the harm in their power, but to injury insult was to be added in a manner I hope never to witness again. A rebel cavalry officer named Brewster, who stated he had been detailed by General Van Dorn to "march off every sick man that had not been paroled, collected together, pistol in hand, about 150 sick soldiers, forced them to rise from their beds and fall in line, threatening to shoot the medical officer who expostulated with him, and actually made the poor fellows, suffering from typhoid fever, pneumonia, and diarrhea, start

with him on the road. The men fell down in the street and had to rise again for fear of being shot, when they were so weak that the slightest motion was agony. On being impudently if there was any thing in the name of humanity that could be done to stop his brutal proceedings, he finally consented to let them alone on receiving a paper, signed by all the surgeons present, stating that the men were too sick to walk, and their removal was an impossibility.

#### A NEWSPAPER CORRESPONDENT WRITES

One of the enemy's cavalry rode up to a wagon containing a wounded German soldier of Captain Langworthy's company, Second Wisconsin regiment, and, dragging him out by the hair of the head, piercing him through the body with his sword, yelling, "I'll teach you d-d black abolitionists to come down here to fight us." The trooper then rushed upon the driver of the wagon, and, with a back cut of his sabre, nearly severed the man's head from his body, and he fell lifeless among his horses.

At the battle of Bull Run, an Ohio surgeon detailed for duty in a hospital, testified that it was assiduously shelled by the rebels while the wounded of both armies were being cared for in it.

The Philadelphia Inquirer contained the following, shortly after the battle:

A lieutenant of an Ohio regiment, now in this city, and who was at the battle of Bull Run, states that he saw several of our wounded bayoneted and having their throats cut by the members of the Alabama and Georgia regiments. The poor fellows begged for their lives, but their pleadings were disregarded, and with an oath the death wound was inflicted.

#### MURDERS OF DEFENSELESS MEN

The following account of the murder of General Robert M Cook is in point:

On Tuesday last General Robert M Cook, who was at the time very sick, was in an ambulance near Salem, Alabama, on his way to his brigade. The ambulance was traveling over the usual military road, and about ten o'clock in the morning it arrived at a plantation where there was an abundance of water. After refreshing themselves they passed on with the wounded General. Intelligence of his whereabouts and condition was quickly spread, it is supposed, for before the ambulance had proceeded three miles the driver discovered that he was pursued by guerrillas.

It was impossible to think of flight, and Gen. Cook's condition prohibited any idea of rescuing him. The guerrilla leader ordered the ambulance to stop, the assassins at the same time surrounding it. The vehicle was then upset, and the sick officer tumbled into the road. While on his knees, helpless and sick, he was fired at by a ruffian, and shot through the side.

The wound was fatal, General M Cook surviving it but a few hours. He bore his sufferings heroically, and to the last manifested an undaunted spirit. His last words were: "Tell Aleck (alluding to his brother, General Alexander M Dowell M'Cook) and the rest that I have tried to live like a man and do my duty."

Commissary Packham, of Piatt's Zouaves, communicates the following narrative of the murder of two members of that regiment by rebel guerrillas in Western Virginia:

A few days ago John Costallo and John Cerve, Company D, with a loyal Virginian named Collins, attached to Company G as guide, were sent after a detachment of the Second loyal Virginia Cavalry, whom our colonel desired to be nearer our lines. When about 16 miles from camp they suddenly came upon a party of rebel militia, who fired, wounding the Virginia guide. Costallo and Cerbe instantly returned the fire, but before they could reload they were overpowered and taken to Mrs. Gilkinson's. Next morning the rebels consulted upon the disposal of their prisoners. Some were for sending them to Richmond, some to their own head quarters at Logan Court House, some for killing them, and Mrs. Gilkinson, to the eternal disgrace of Southern female friends, wished one to be killed on her porch, so that she could dance in his blood.

The killing was done in the following manner, communicated to me by H. Mays, in our hospital, a short time before he died, from a wound he had just received while attempting to escape from the guard house.

These are his dying words:

In the morning we took one up the run, a quarter of a mile from Mrs. Gilkinson's mill, tied his legs, and fixed him to a tree. Bill Pritchett, Lew Pritchett, Isam Miller, and Stevens, walked off a piece, and shot at him till they killed him. Question. Did you shoot? Answer. No; I and three others stood by; we all went back to Mrs. Gilkinson, got the other Zouave, brought him up the run,

and he was killed? Q. Did you try to prevent them being shot in that manner? A. Yes. Q. Did either of the poor fellows say any thing while they were being so slowly and cruelly murdered? A. Yes; for as we took the last one up the run, past the first one shot who lay at the tree, he stopped, looked at the dead body, and said, O God! don't murder me that way; I can die like a soldier, but, for God's sake, don't murder me; shoot me here! And he unbuttoned his Zouave jacket, and tore open his shirt. Q. Did you not persuade your men to have mercy, and grant the poor fellow his wish? A. Yes; I said I would see him safe to Logan; but they fixed him to a tree, and shot him. Q. How many times was he hit before he died? A. They had about three shots apiece at him. Q. Did they shoot at him after he was dead? A. No. Q. What became of Collins, the Virginian? A. They kept teasing him at Mrs. Gilkinson's till near noon; then took him away up the run, and killed him. I did not shoot once; all the shooting was done by the two Pritchets, Miller, and Stevens. Pritchet said they were to see who could hit nearest his heart without killing him. Q. How many times do you think the boys were hit? A. All the men shot three times; they hit every time. My name is Mays. I live on the Beech Fort. It is true.

The wretch soon died. Since writing the above our scouts have returned. They have killed Lew Pritchet, and got 13 prisoners, among whom we are in hopes to find all the abettors in the above horrible affair.

Yours respectfully,  
A Packman, Piatt's Zauaves,  
Commissary Thirty fourth Regiment O.V.  
OUR DEAD SCALPED

A correspondent from the West says:

The committee under the resolutions of inquiry are receiving testimony from Pea Ridge, showing insensibility that there our dead were not only scalped by the rebels' Indian allies, but in other respects outraged.

Another writes:

You will of course have heard of the fact that the rebels had some three thousand Indians under the command of Albert Pike. Also that some twenty of our men who fell in the engagement under Colonel Osterhaus on Friday, and under General Davis on Saturday, and had the misfortune to be left on the field, were foully and fiendishly scalped, murdered, and robbed by these red skinned wretches.

### CONTRABANDS DRIVEN SOUTH OR SHOT

All "contrabands" captured by the rebels on the Federal wagon trains are immediately shot. Twenty thus killed are lying on the Murfreesboro Pike.

While at Aldie, on Thursday last, two citizens, named Moore and Ball, came within our lines and were detained as prisoners. The first named is a son of the proprietor of Moore's flour mills, at Aldie, on a branch of Goose Creek, and the latter is a large planter in the same town. They had "done nothing," so they said, and were neither bushwhackers nor soldiers, and were surprised at being detained within our lines when so near their homes, from which they had been absent some time. Upon being questioned closely they admitted that they had just come from the James River, and finally owned up that they had been running off "niggers," having just taken a large gang, belonging to themselves and neighbors, southward in chains, to avoid losing them under the emancipation proclamation. I understand, from various sources, that the owners of this species of property, throughout this section of the State, are moving it off toward Richmond as fast as it can be spared from the plantations, and the slave holders boast that there will not be a negro left in all this part of the State by the 1st of January next.

The rebels in Secession are busily engaged just now in running off to Richmond and beyond negroes and conscripts. A Union man, just from below Culpepper, says that he saw droves of negroes and white men on the road at different points, all strongly guarded. He does not exactly know which excited his pity most, the white or black men.

### MISCELLANEOUS BARBARITIES

The following are a few extracts culled from army letters:

"Every day new barbarities perpetrated by the rebels come to light. This week two soldiers who had straggled from the ranks on the march from \_\_\_ were found, it is reported on credible authority, by the roadside with their throats cut from ear to ear.

"Here the rebels were guilty of barbarous atrocities. Many of the dead had their throats cut, and presented a horrible spectacle. One man was brought in who had had his eyes picked out by their bayonets. In short, they evinced the most unrelenting fury on finding this way of retreat cut off to them.

"Numbers of our men were found

with their throats cut, and some had their eyes picked out. One was found tied to a tree. But enough of those horrors. I must conclude. "To what depths of inhuman wickedness men, or fiends, can descend! Prisoners taken by the rebels were after ward deliberately murdered, and the fingers of our dead cut off to secure rings. We grow wiser every day.

One man says: "They kept bayoneting me until I received fourteen wounds. One then left me, the other remaining over me, when a Union soldier coming up shot him in the breast, and he fell dead. I lay on the ground until ten o'clock next day.

"The fellow at first made no reply, but, stooping down, seized the dead man by the hair and dragged him partially out of his grave, in order to get at the buttons on his clothes for trophies.

"Another saw the brains of the wounded being beaten out by clubs, thus confirming the previous newspaper reports.

There is enough in these extracts to bear out the picture, horrible as they are, and to serve as a complete refutation of Jeff Davis's claim to superior chivalry. Will the foreign journals, who have made such an outcry about Butler and M'Neil, be so good as to let their readers hear of a few of these cases?

### Popular Mechanics

April 1954



### Slingshot With Sighting Ring Shoots Arrows or Pellets

Arrows or steel balls are shot from a metal slingshot designed for hunting and target practice. Steady aim is assured by a sighting ring and a balanced pistol grip. Powerful and accurate, it will kill foxes, coyotes and deer.



# TIPS FROM GERMANY

by Philipp Rauch

In spite of your wonderful "CYANIDE SMUDGE POT" I researched some other loads for this type of grenade. The following I found were:

## CARBONMONOXIDE

Carbonmonoxide is a strong and malicious poison, because it has no warning effects on man. The somewhat peculiar odor cannot be smelled by everyone. The toxic effect depends on building carbonmonoxidehaemoglobin in the blood, where it blocks the oxygen absorption, and on a specific poison effect onto the nervous system. The poison effect begins very late, at large concentrations those poisoned notice it first, when the deadly dose is already exceeded. Unnoticed breathing of CO in a concentration of 0,05% during several hours will cause death. Concentrations of about 0.5% will be deadly in five to ten minutes! For further information over CO read SURVIVOR 1 page 413. To produce it you must add strong sulfuric acid (H2SO4) to formic (ant) acid (HCOOH) and lots of carbonmonoxide (CO) will be generated. I would use it only in closed rooms, so there is a bigger chance to get a deadly dose. An even better idea is to use it where an old coal fired stove is, so the police may think that they died of smoke inhalation.



## CHLORINE

Chlorine, a yellow-green, poisonous gas, belongs to one of most reactivitiest elements. It reacts with nearly all metals gently under intensive illumination, at which humid chlorine acts more violently than dry chlorine gas. Very dangerous are mixtures (Mol 1:1 mix) with hydrogen. It will almost explode under the influence of light. Chlorine has got a characteristic, pungent odor, which will be smellable in a concentration of 01 mg/l. Chlorine is a strong irritant gas, which, even in a situation of 1:200 with air, will attack the respiratory organs so long suffocating follows in a short time period caused by burns of the respiratory organs and the lungs (95 to 100% of respired chlorine are absorbed by the body). The poisoning will start instantly after breathing the chlorine gas. The symptoms are irritation of the respiratory organs, thereto shortness of breath, emoptysis and little pulsation. Add strong hydrochloric (muriatic) acid (HCl) to potassium permanganate (KMnO4), or sodium hypochlorite (bleach) (NaClO) and hydrochloric acid (HCl), or sodium bisulfate (SANIFLUSI) (NaHSO3) and sodium hypochlorite (NaClO). Further Information in GWBC page 110 (Medical Student's Chemistry page 55).

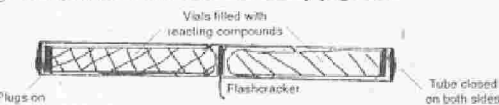

## HYDROGEN

Hydrogen is a very inflammable, explosive gas (even in conjunction with CO or Cl). It is produced by adding to zinc (powder) (Zn) some strong hydrochloric acid (HCl) page 105 GWBC (Med. Stud. Chem. page 37)

## AMMONIA

50 grams lye (sodium hydroxide) (NaOH) ammonium nitrate (NH4NO3) or ammonium sulfate ((NH4)2SO4) is brought into contact with water (16 (MSC page 72).

## OXYGEN

Add strong sulfuric acid (H2SO4) to manganese dioxide (MnO2). GWBC page 106 (MSC page 40).

I think you would make a sort of explosive with use of acetylene produced by carbide. Try to wrap some wet ANTI into aluminium foil and fasten it inside to the cap. Don't forget to put some grains of rice into the ANTI. Maybe it won't function at all, because the gas produced by the carbide will most times ignite by itself. I've made such a similar device a time ago. But instead of using acetylene from carbide I used a butane/propane lighter refill cartridge with a flash-cracker fastened to it's thin sheet metal or plastic body. The flash-cracker is made out of a plastic tube, filled with DET-X (or any other flashing compound).



## MATERIAL REQUIRED

A piece of plastic tube - min. 10cm X 1cm; Knife; Hot glue gun or ribbon epoxy; Wooden rod - max. outside diameter of tube; Cotton wool or strips of an old wig; Friction tape; Fuse; Butane/propane lighter refill cartridge; DET-X or any other flashing compound.

## PROCEDURE

1. First cut the plastic tube into a 10cm piece and fill one end at least 0,5cm with some glue or epoxy.
2. Then fill, a bit at once only, and tamp with the wooden rod until 2cm away from the open end.
3. Stop filling and tamping, insert fuse, fill loosely with DET-X until 1cm from top.
4. Next, get the cotton wool, place it on the powder and fill with epoxy.
5. Take the flash-cracker and tape it tightly to the cartridge.

Your bomb is now complete!



## THE JOYS OF SOLDERING SQUIBS

by Kurt Saxon

### SOLDERING IRON (Kit) 30 WATTS, 120 VOLTS

- Light Duty, intricate soldering
- Electronics, radio, TV, kits, fine wiring, hobbies

#### Features

- Develops 920°F. tip temperature to make better solder joints.
- Efficient mica-insulated, nichrome heating element provides more stable tip temperatures and longer element life.
- Pencil type handle is cooler to use and provides better handling and control.
- Tips are interchangeable.

On page 45 of Poor Man's James Bond New Improved you'll see a diagram of a typical pipe bomb with watch timer and a flashlight bulb as a detonator. I was never satisfied with that sort of detonator. It costs and unless great care is taken the delicate filament will break when you break the bulb. Also, it might break when you put it in and pour the powder in around it. Undependable but the best I knew twenty one years ago.

Since then, electric squibs have been sold in every hobby shop selling rockets, for about five for a dollar. These squibs are made of two eight-inch lengths of 22 gauge insulated wire. The business end has a hard plastic oblong holding the ends apart. Across the ends is a bit of hair-thin nichrome wire. Covering the wire is a flammable compound.



COMMERCIAL SQUIB

When the contact is made the current heats the nichrome wire and the compound ignites with a flash, instantaneously. The current is supplied by a 9 volt battery or two AAAs. Probably two AAAs would also work.

I wanted to reproduce the squibs. I had bought ten rolls of 35 gauge (hair thin) nichrome wire some time back. I think you can get small rolls of such nichrome wire from the same hobby shop selling rocket-firing squibs. If you can't, I'll sell it to you for \$1.00 a yard (10 yard minimum) with any order.

In a pinch, you can use the coil from one of those coffee cup warmers. It's just a little thicker than what I have. Thicker still but still thin enough is the coil from a hair dryer. Thicker than that and maybe the AA or 9 volt batteries wouldn't be strong enough. See for yourself.

The tools you need, aside from the soldering iron, are a razor knife and maybe a pair of needle-nosed pliers.

I went to Wal-Mart and bought 50 feet of 22 gauge insulated wire for \$4.00 and a soldering iron kit for \$6.97. The kit comes with soldering iron, one ounce of rosin-core solder in a coil and three soldering iron tips.

I had never soldered before and made every mistake possible. Soldering is so simple I don't think there are any instructions on it. But to the beginner, the solder runs every which way but where you want it. The flux in the middle of the solder drips all over and seems to keep the solder from sticking. The solder rolls away from the target in a most aggravating manner and you might want to throw the whole mess in the garbage.

As a child I had watched my older brother solder the crystal radio set he was always playing with. So I knew it could be done.

#### Caution

- Hot irons can cause severe burns.
- Use carefully. • Always rest iron on holder.
- Keep away from combustible materials.
- Unplug after use.
- Not a toy. Store out of reach of children.

#### How To Solder

1. Use the correct iron. Wattage and tip size should be sufficient to thoroughly heat the parts being soldered.
2. Use the proper solder. Solder having higher tin content (i.e. 50% tin) is preferred.

Solder	Uses	Metals
Rosin* Core	Electrical Work, Electronics, TV, Radio, Appliances, Motors, Generators.	Copper Silver Plate Tin Plate Gold Plate
Acid* Core	General Purpose, Toys, Crafts, Copper Tubing, Gutters, Plumbing	Copper, Steel Galvanized Iron Nickel Alloys, Tin Plate, Plate Brass

\*For electronics and electrical work use only rosin core solder. Use acid core solder only where flux residue can be washed away.

3. Clean the work thoroughly to ensure good bond using steel wool, fine sandpaper or file. Clean printed circuit boards gently.
4. "Tin" tip of iron. As iron heats up, apply solder to tip surfaces.
5. Heat the work surface thoroughly using entire tip surface. Then apply solder to heated parts at the point of tip contact. Don't over solder.
6. Allow solder to cool & set before moving parts.
7. **MAINTAIN IRON FOR LONGER LIFE**
  - a. Clean tip with steel wool or file. Flatten tip.
  - b. Always keep tip well "tinned".
  - c. Always loosen tip with pliers after use to prevent tip from "freezing" in position. Applying graphite powder to threads before using is recommended. Tighten tip prior to using again.

My first ignorance was in melting the solder for it to drop down on the work. Wrong. You must put the tip of the iron on the point you want to solder and then melt the solder around it. Even so, it took many tries before I got the hang of it and got the solder to cling to the wires I meant to connect. You develop a kind of feel for it. You might think you just can't do it and finally you find yourself just doing it.

Before you can solder, the ends of the wires need to be stripped of their insulation. If you don't have a wire stripper, just use a razor knife and hold it about a half-inch from the end and slanted. Press gently and pull the wire and

the insulation will peel off, exposing the wire. Then pull the remaining insulation back and cut it off.

Anyway, follow the diagram on page 45 and start with two AA batteries. It helps to use Scotch tape to hold the wires to the contact points. Tape the wire alongside the battery and bend the bare wire so it rests on the contact point. Prop it upright. Use the needle-point tip for this work. Put the tip on the wire and hold it a few seconds to heat the wire. Then put the end of the solder to the tip of the iron. As soon as a drop rolls over the wire, lift the tip off and see if both the wire and contact point are joined. If it isn't, try again. You may be able to use the tip of the iron to roll the bead of solder in place.

When you've fiddled around until you've gotten both ends of the batteries soldered to their wires, lay one wire down on a board. Lay a three-inch wire about a half inch from the longer wire and Scotch tape both wires to the board so they lie flat. Then lay about an inch of nichrome wire across the two exposed wires and Scotch tape it down as in the diagram.

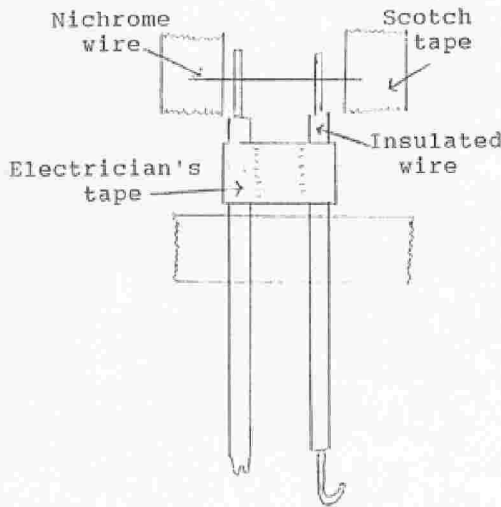

HOMEMADE SQUIB

Put a bead of solder on each copper wire, covering the nichrome wire at those points. Bend the two ends of the copper wire into hooks, to test the squib. It only works one time, as the heat usually melts the solder and breaks the connection. Once is enough, as that instantaneous burst of heat also detonates the powder.

When you know how to solder the nichrome wire to the copper wire, and have the excess nichrome wire cut off, put a pinch of match-head powder (Issue 1, page 16) over the nichrome wire. Then connect the hooked ends. You don't really need to connect the hooked ends. Just a touch of the copper wires causes the nichrome wire to instantly deto-

nate the powder in a satisfying, almost explosive flash. Glorious!

To keep the copper wires separated so they stay in place after the soldering, wrap a half inch wide strip of electrician's tape about a half inch below the nichrome wire and around the two insulated wires.

The commercial squibs have a flammable tip. These don't really need one if the squib is buried in powder. Even so, if you want flammable tips, you can put on your own. To do this, get some mucilage from an office supply store. That's the amber colored glue everybody used before Elmer's white glue came into use. I don't trust the white stuff but you can try it.

Anyway, mix half mucilage and half water and then mix in enough match-head powder to make a stiff paste. Dip the end of the squib into the paste and let it dry. The paste-covered squib doesn't ignite as quick as powder laid over the wire. This is a difference of a fraction of a second, but would be important if used for a trip-wire where the contact might be broken before ignition of the paste covered squib.

Therefore, when the bare squib is used in dry powder, a looped wire, activated as shown is good. For a longer contact needed by the paste-covered squib, a permanent contact, such as a clothespin is best.

d. Open loop. The open loop arrangement shown is the ONLY break in an otherwise complete electrical circuit. A wide variety of actions on the part of the victim could result in pulling the two bare ends of the wire together.

III-12

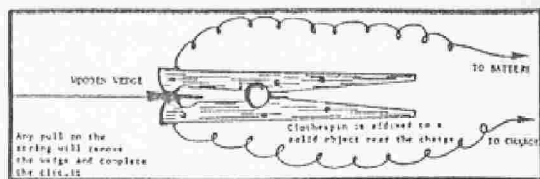
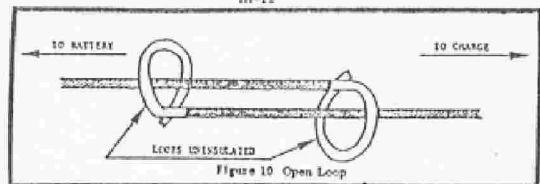

When used with a watch timer, the connection shown in PMJB New Improved, page 45 is used.

**SANI-FLUSH TOILET BOWL CLEANER (GRANULAR)**  
(Boyle-Midway)

Sodium bisulfate *	62%
Inerts including Sodium carbonate, Sodium chloride, Colorant, Fragrance	38%

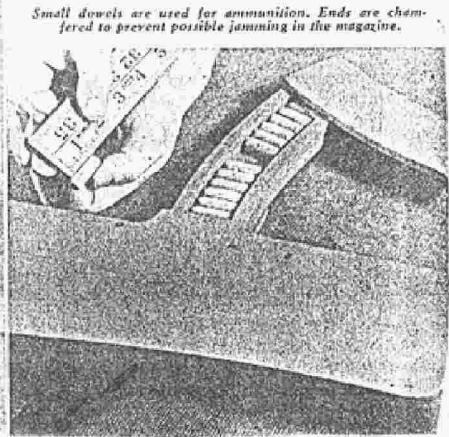

Small dowels are used for ammunition. Ends are chamfered to prevent possible jamming in the magazine.

## MODEL SUBMACHINE

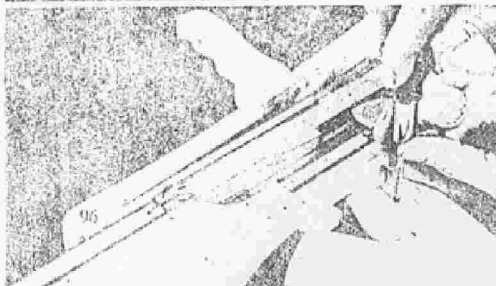
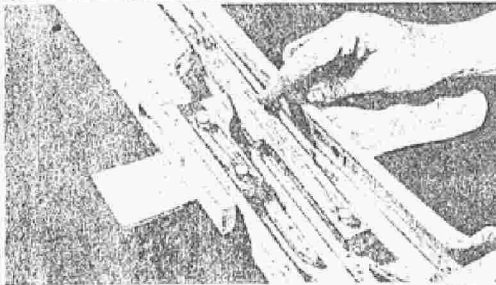
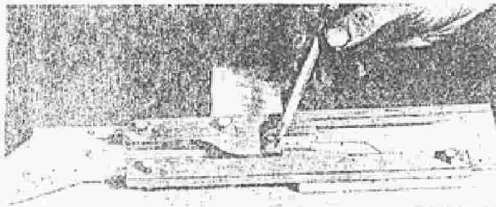

Here Is A Repeating Action "Sub-machine Gun" That Will Delight That Boy Of Yours. While Certainly No Lethal Weapon It Will Knock Over Toy Soldiers Quite Easily. Holds Fifteen Wooden "Bullets" Firing As The Front Handle Pumps Back And Forth.

*Mechanix Illustrated December, 1941*  
by Reginald O. Lissaman

ANY small boy will want, and be delighted with this toy submachine gun, which holds fifteen shots in the magazine and fires continuously, until empty, as the "tromboning" action is worked. Made entirely from wood, simple of construction, and employing no "hard to get" parts, this gun would make an excellent mass production product for any guild club doing such work for gift or sale.

The body of the gun, housing the mechanism, is built up on the side plate having the projection to which the magazine is secured. If the modeler makes up a set of full sized

*Top left: Cocking bar and firing pin are in place on side plate. A small screw eye (next to pencil point) is used for attaching spring or rubber band for power. Center: Attaching magazine to gun. Leave room for loading bar to slide freely beneath. Bottom: Cocking bar and firing pin are guided by short projecting dowels which slide in "tracks" formed by tracing small rings to side plate. Finger points to wooden spring causing cocking bar to engage firing pin.*

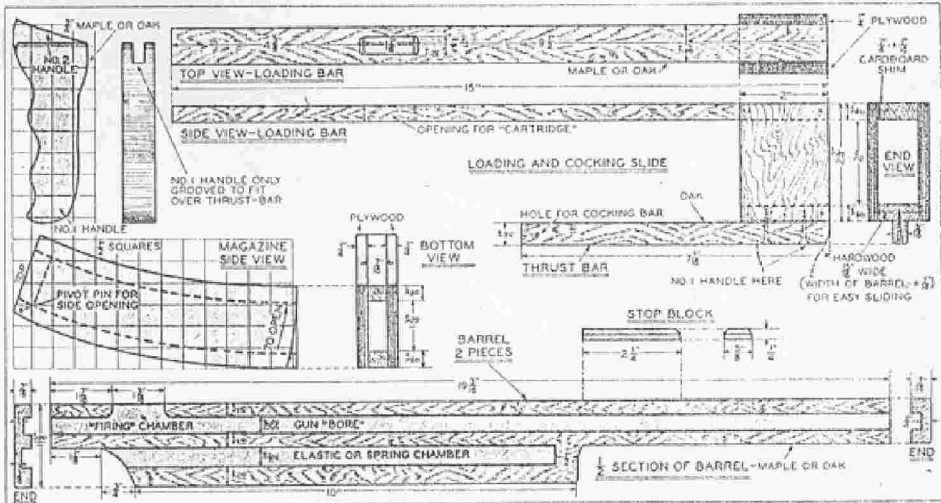

# GUN Performs Realistically

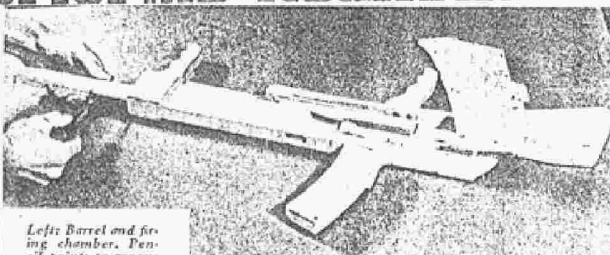
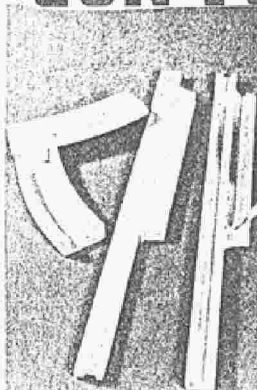

Left: Barrel and firing chamber. Pencil points to groove for placing rubber band "power." Above: Small block screwed to barrel stops forward sliding action. Right: Two or three rubber bands are pulled in place with stovepipe wire.

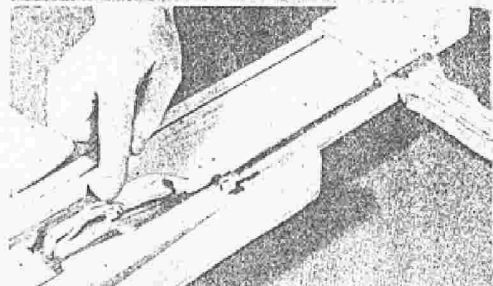

drawings of all the parts on light card or heavy paper and makes cut-outs from them, much of the fitting and adjusting may be done before actually cutting the parts from wood. This minimizes the chance of error caused by working from small drawings.

The short dowels which project through the firing pin and cocking bar should slide freely, but not too loosely in the tracks formed by the small rippings, which are



Right: While casein glue may be used at points in construction where removal will be unnecessary, do not use any when attaching covering side plate. Small rivets hold it down and permit removal for adjustments, fire power renewal, etc.

### Jamming In The Firing Chamber

First be sure that sufficient room is allowed to permit the bullets to fall easily into place. If it is not cured by the above the trouble will probably be caused by the firing pin not being drawn back far enough to give the bullet time to drop completely into place. *Cure:* Shorten firing pin. If the barrel is made of soft wood the striking shoulder of the firing pin will bruise into the rear end of the barrel, having the effect of lengthening the firing pin. If such occurs it may be found necessary to provide something harder for the firing pin to strike on, such as a little piece of metal or hardwood block. However, if the barrel is made of hardwood trouble is unlikely. When the gun is used out-of-doors where excessive ammunition loss is likely, it is suggested that the "bullets" be not used, instead, peas or small stones should be used. This will necessitate single shot loading. Each individual shot should be placed directly into the firing chamber for single shot fire.

bradded and glued to the side plates. Punch pin holes through the full sized drawing of the side plates, at the exact location of these rippings so both plates are identical.

The barrel is made as shown in one of the photos, both sections being glued and bradded together. Avoid surplus glue that might foul the bore.

In the "tromboning" assembly, the box-shaped part immediately over the handle grip is made to slide freely over the barrel of the gun, plus a little extra clearance for the two coats of paint used in finishing. The mechanism is powered with two or three good weight office rubber-bands.

All in all construction is simple, as will be seen from a little study of the drawings and photographs. Should any trouble in operation be found, the cure will lie amongst the following.

### Jamming In The Magazine

This will occur if the gun is shaken enough to cause the "bullets" to drop down vertically, instead of horizontally. *Cure:* Swing cover open and re-stack the bullets.

The simple but excellently working wooden mechanism will be a delight to the youngster who must see "why it works"—that is if Dad ever gets through playing with it.

*Full sized patterns of the various parts can accurately be laid out in squares from the drawing below. Transfer patterns to wood and cut out.*

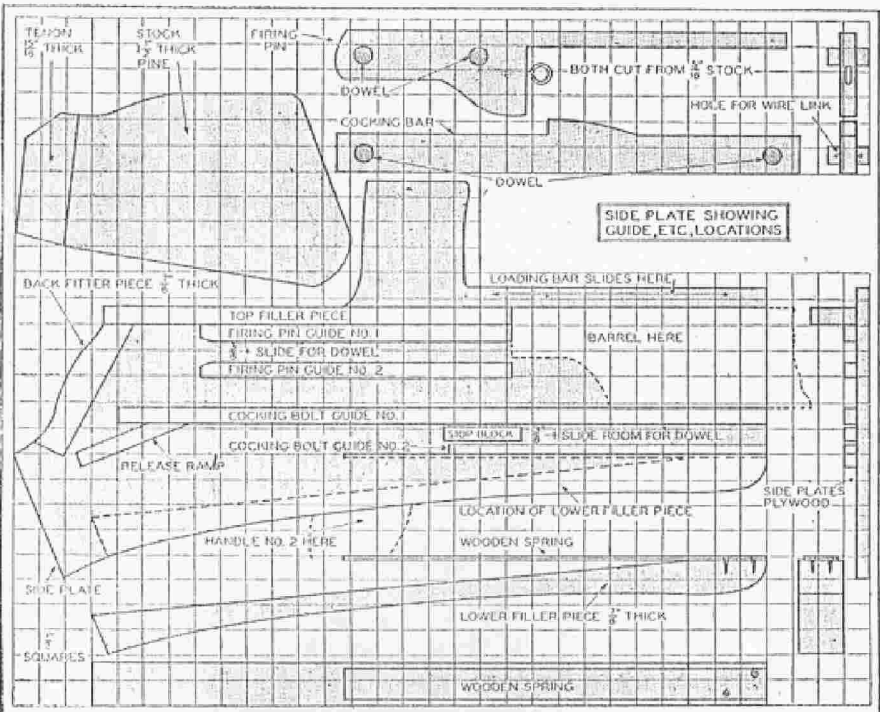

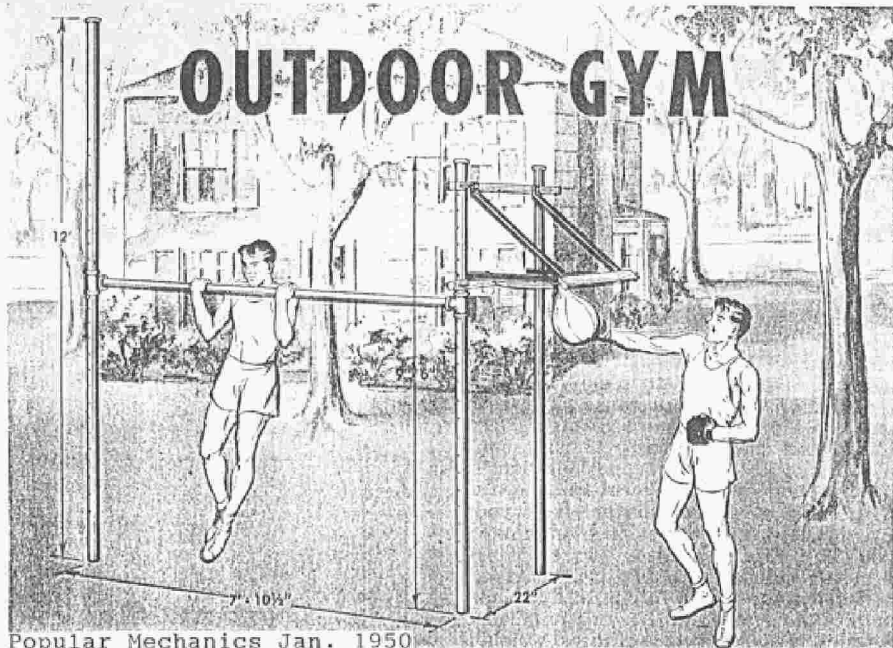

By Thomas Trail

This simple, sturdy outdoor gym can be built in the yard with several pieces of pipe and a few fittings. Both the horizontal exercise bar and the support for the striking-bag platform are adjustable for height. Three uprights of 2-in. pipe, one of them a 12-ft. climbing bar, are anchored in concrete. A series of 1/2-in. holes are drilled in two of the uprights on 3-in. spacings, and each upright is screwed into a coupling on the upper end of the length of pipe which is embedded in concrete. Use 2 1/2-in. pipe tees with reducers on the ends of the 1 1/2-in. exercise bar. The detail at the right shows the assembly of a bolt which supports the bar at each end. The striking-bag frame, which is attached to the uprights with U-bolts, is detailed at the lower right

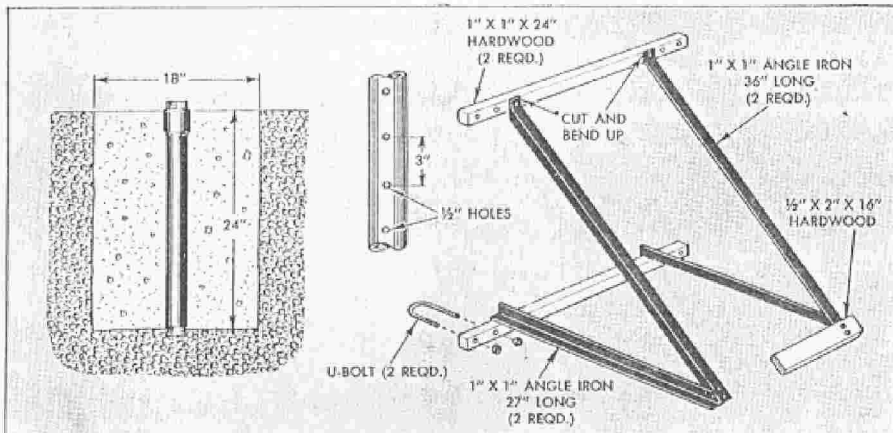
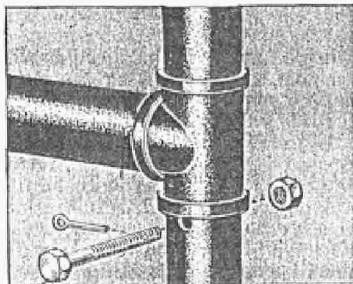



Charles Ford funnels a charge of black powder into his muzzle loader.



*The muzzle loader was one way. Now smart shooters save money and gain accuracy by reloading their fired shells.*

*By Raymond R. Camp  
Gun Editor, N. Y. Times*

*Mechanix Illustrated October, 1949*

## Why Not Load Your Own?

**W**HEN you consider the labor, precision and materials involved in the production of a metallic cartridge, the present market price of this commodity is reasonable, but it is still a stiff outlay for the shooter who likes to get out and burn powder.

There is a solution to this problem. During the past few years thousands of shooters have found it, and have discovered that its practice provides a new and interesting angle to the shooting hobby. The answer is—reloading. Through the medium of a moderate outlay for equipment, and the purchase of lead, powder and primers in bulk, you can turn out from five to eight loaded cartridges for the price of one factory round. What's more, the shooter with an urge toward experimentation can increase his shooting pleasure, provided he keeps within the bounds of normal safety procedure.

Any shooter whose rifle employs center-fire cartridges finds that his sport has in-

creased greatly in cost since the war, and the majority are faced with one of two courses: either they must cut down their shooting, or take up reloading. Those unfamiliar with the situation assume that the production-line machinery of the modern arms companies can produce ammunition much cheaper than the home reloader. These shooters fail to consider the fact that cartridge production is slanted toward the one-shot load, and that the cartridge case, the big expense item, can be reloaded many times with complete safety.

Many of the real gun cranks have turned to reloading not to save money, but because by this means they are able to obtain real uniformity and precision, and the same thing has influenced many match shooters. No two rifle barrels are the same, and by experimenting with varied loads and bullets you can determine the load which your particular barrel handles best. This can mean everything to accuracy.

Upon reading the list of steps to be fol-

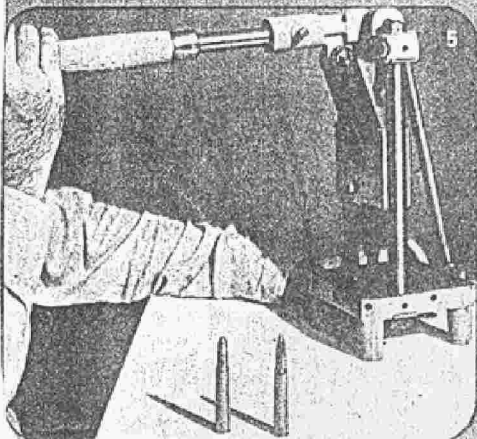
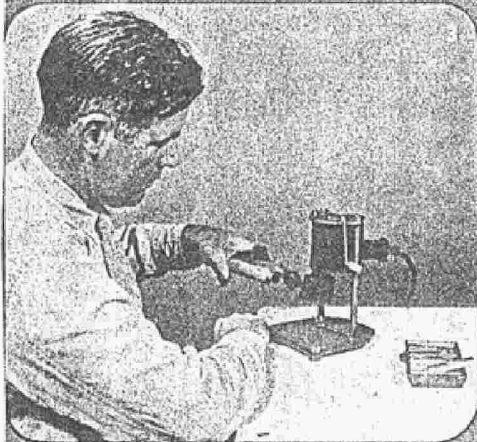
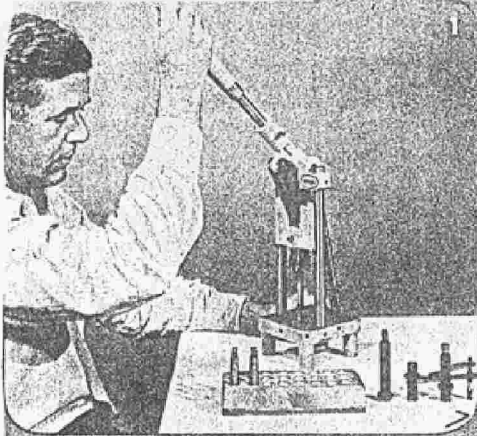

- 1 RELOADING TOOL** has a number of dies for removing old primer from shell, resizing neck, inserting new primer and later, seating bullet.
- 2 WEIGHING** each individual charge of powder by scale is still the most accurate method, although inexpensive measurer simplifies the job.
- 3 LEAD** can be melted in an iron skillet, but this electric pot is nicer. Handle lifts to pour lead into mold, in left hand in photo.
- 4 BULLETS** are ready after a few seconds. Cutter slices off their ends, then handle is opened and tapping with wooden mallet jars them loose.
- 5 SEATING** is done by reloading tool. Jacketed bullets can be purchased ready-made if desired. Compare reload, left, with factory load, right.

lowed, you may feel that the time involved is not sufficiently short to justify the saving. However, it is not difficult to turn out 100 reloads in the course of an evening, and if you are using a caliber for which factory loads are 12c each, you have saved about \$10. At the same time, you have spent an enjoyable evening, and have provided yourself with 100 rounds of accurate ammunition.

Another factor which many do not realize is that even with the modern precision machine, highly-skilled labor and a considerable amount of hand work is still required. Others, having read occasional articles on reloading in some of the outdoor magazines, are awed by the technical knowledge apparently required. This also is a fallacy, for any individual with sufficient technical skill to drive a nail in a board without smashing his thumb can learn to reload his own cartridges in one easy lesson.

The equipment required may seem rather elaborate, but the man who really enjoys shooting and would like to do more of it will find this equipment pays for itself in a couple of months. One tool, with the half-dozen inserts or dies will do most of the work, and you do not have to buy the most expensive one to do a good job.

The majority of home reloaders use lead bullets which they cast themselves, but if you prefer jacketed bullets, these can be obtained at your gun store in large lots at a slight increase in cost. For ordinary shooting, or for most varmint shooting, the lead bullet will prove just as satisfactory and you can always buy a few jacketed bullets for your big game hunting, eliminating a few of the steps normally followed in the reloading procedure.

Let's run through the routine. You have on hand in addition to enough empty cartridge cases, your reloading tool, a few simple, home-made items of equipment which we'll mention as we go along, and the materials required for the job: primers, powder, lead, wax, etc.

First we have the casting of the bullets. An iron skillet will serve for melting the lead, or you can buy an electric unit. If you employ old lead pipe as your source of lead, be sure you skim off the dross and dirt on top of it when molten. Then add one part of tin to every 14 or 15 parts of lead. With a small ladle pour the molten metal into the single or double bullet mould. Count five, then tap the sprue cutter with a wooden mallet; this cuts the base of the bullet to a flat face. Open the mold and tap it with the mallet, letting the bullet or bullets drop on a cloth pad. When you have

a sufficient stock of bullets, begin the next step.

This is the lubrication. You can make your own lubricant, using equal parts of paraffin and beeswax thinned lightly with vaseline, or you can buy a prepared lubricant. Take an old pie tin, stand your bullets on their bases in it and pour the melted lubricant into the tin until it is just over the top groove in the bullet. When lubricant has hardened and cooled, you are ready for the next step. Take a cartridge case, cut off the base, and ream the neck with your reloading tool and the correct die, until a bullet passes through it without too much pressure. Press this down over each bullet as it stands in the lubricant until you hit the bottom of the pan. The next bullet will push the first one out of the neck, and so on. This will trim off the excess lubricant.

Those who are planning to use light loads will be able to skip the next step, but if you are using high velocity loads, a gas check should be tapped on the base of each bullet, protecting it from the hot gasses. These are tiny copper cups which fit the base of the bullet. To attach them, merely bore a hole the size of the bullet and half as deep in a block of wood. Drop the bullet in this hole nose first, affix the gas check and give it a light tap with the wooden mallet, then shake out the bullet.

Next is the bullet sizing, to make sure it is the correct diameter. An inexpensive tool can be purchased for this. It is merely a hollow tube with a plunger. The bullet is placed in the tube base-first, and pressed through with the plunger. Once the bullet is started it may be necessary to strike the plunger with the heel of the hand or with the wooden mallet.

Now for the preparation of the case. First insert the decapping die in the reloading tool and begin feeding it fired cases. One operation of the lever removes the old primer. When your primers have been removed, clean the rim of the primer pocket by scraping it with a small knife blade or screwdriver point.

The next step is to "chamfer" the rim of the cartridge case neck. This is quick and simple. A small reaming tool is used, which creates an inside bevel and permits the smooth entrance of the bullet.

Then the priming unit or recapper is used in the reloading tool. Most of these resize the neck of the case at the same time the primer is inserted in the base. The cartridge is now ready for the powder. For a few dollars you can buy a powder measure that

will save you considerable time, but for really exact measuring, the majority of reloaders stick to the balance scale, which weighs the load to a fraction. A small funnel in the neck of the case will simplify this task.

Once loaded, the cases should be placed in a block. This can be turned out at home. Get a piece of two-by-four and bore twenty or thirty holes, slightly larger in diameter than the bullet base and an inch deep. These will hold the loaded cartridges upright and make them easier to handle.

The final step is the seating of the bullet, for which a die is provided in the reloading tool. The important step in this procedure is the adjustment of the bullet seater to the exact depth desired. For the novice a little trial and error will supply the correct answer.

You now have a cartridge of your own creation, and like the angler who finds greater sport in taking trout on flies tied by himself, you will get a bigger thrill when you touch off a round of your own loading.

Reloading tools can be obtained today for almost any caliber, and if you are interested in experimentation, you can get several moulds providing different bullet weights and designs for the same caliber. Also, through reloading, you can experiment with velocities. This, however, can be a dangerous procedure

if you fail to heed the charts on maximum loading. Your rifle is designed to withstand only certain maximum pressures, and charts are available which give you the maximum powder loads for the various calibers and makes.

You can obtain catalogues and handbooks from most of the makers of reloading tools, and if you are planning to take up the activity with real interest, it would be well worth your while to invest in *The Complete Guide to Handloading*, written by Captain Philip B. Sharpe, and published by Funk & Wagnalls. Most materials can be purchased from Stoeger Arms Corp., 507 Fifth Ave., New York City.

Those who are frightened at the thought of keeping powder in the house have no more cause for anxiety than they have at the idea of having gasoline in the tank of their car. Store the powder in a cool, dry place, be certain the cork sealing disc is present in the cap, and stop worrying. Don't make a habit of picking up the powder can and shaking it violently to determine how much you have left, however. This shaking might build up static electricity, and when the smoke clears away you may be holding a harp instead of the can. •

### SILENCERS MADE EASILY

by A.P. Holmes

There are many designs and blueprints of silencers available for sale. The most effective of these designs incorporates the usage of baffles within the silencer. These baffles have to be painstakingly welded, one by one. Some designs require as many as 17 such baffles. If these baffles are not welded properly, the silencer could blow up in your face. Upon examining the best of the baffle-type silencer designs, I discovered that they are nothing more than modified automobile mufflers.

The smallest, yet still effective, muffler available for such modification is the Briggs and Stratton, M 110, 5-8 horsepower, lawn mower muffler, with 3/4 inch I.D. and 1 inch O.D. See the illustration. This muffler is constructed of heavy gauge metal that helps to quiet the noise. It also has a very sophisticated network of baffles. Plus, it's already threaded on the inlet side.

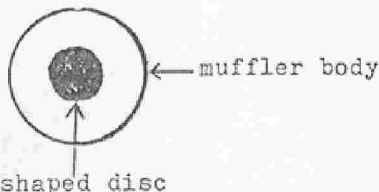
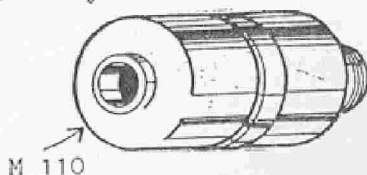

Looking inside either end of the muffler, you will

see a coin-shaped disc, in the center, preventing you from looking through one end to the other end. At this time you must decide on the caliber of gun you wish to silence. The silencer inner barrel will fit through this coin-shaped disc, after the disc has been properly drilled to allow the silencer inner barrel to fit snugly through it.

Most silencer experts agree that a revolver allows too much gas to escape around the cylinder, to be effectively silenced. The gas escaping is equal to noise. They also agree that the automatic is much better for silencer applications, because of the lack of a cylinder, from which these gases can escape. The automatic confines these gases better than a revolver does. Automatics without a rear thumb hammer are even better for silencer applications than automatics with a rear thumb hammer, because they don't allow gases to escape out the rear where the hammer is located.

Bolt-action weapons, without a rear thumb hammer, are best, because not only don't they allow gases to escape from the rear thumb hammer location, but they also remain closed at the discharge chamber, until opened manually by the shooter, when ejecting. Therefore any gases in the gun are allowed to dissipate out the barrel and not out the chamber, when the chamber opens to eject the spent shell and load the next round. This is the problem with some automatics.

Also you must take the speed of the bullet into consideration. A super sonic bullet with a speed of more than 1100 feet per sec. will produce a sharp sonic crack, regardless of what you do. A speed of no more than 1000 ft. per sec. is much better for effectively silencing a weapon. A .45 automatic has a slow enough speed, but because of it's size and the amount of gas it generates, it would require too large a silencer to be practical. The .45, .44, .41, and .32 auto-mags, along with the 11 mm., 10 mm., 9mm., 8mm., and even the .22 auto-mag, all have speeds in excess of the 1100 ft. per sec. They can only be effectively silenced with the use of toned down, under loaded bullets. Then any silencer will be effective. The .38, .380, .32, .25, and the .22 automatics in regular bullets, not magnum loads, can all be silenced with great satisfaction. Their speeds are all below the 1100 ft. per sec. The exception is the .22 long rifle, which sometimes comes in super sonic, high power loads.

As stated earlier, bolt action weapons are best for confining exhaust gases because they don't allow gases to escape at the chamber after the shot. The chamber stays closed until opened manually. We also stated that automatics without the rear thumb hammer contain gases better than those with rear thumb hammers. These two facts do not mean that a .38, .380, .32, .25, or a .22 auto, without bolt action and with the rear thumb hammer, cannot be silenced effectively. They can be silenced quite satisfactorily. The facts simply state what is required for near perfection in silencing a weapon. There are many levels of satisfaction less than perfect.

We experimented with a 9 mm. German Luger, with specially, down loaded shells. The Luger had no rear thumb hammer and the shells were loaded down to 950 ft. per sec.

This weapon was then effectively silenced, while retaining considerable stopping power. We also used a .38 Super auto. We had to use a barrel extension on this weapon in order to screw the silencer on the gun. Originally the slide overlapped the barrel of the .38 Super. The .38 had the rear thumb hammer. It's shells were clocked at 850 ft. per sec. The weapon, when fired with the silencer, was a little louder than the 9 mm. that had the special shells, but it was a good second placer. We tried two .380 automatics. One had the rear hammer and one didn't. The .380 with the rear hammer had noise levels similar to the .38 Super, while the .380 without the rear hammer was even quieter than the 9 mm. with the special shells. This was quite a surprise since the 9 mm. was very quiet. The .32 automatic had no rear hammer. It was similar in noise levels to the .380 without the rear thumb hammer. This was very good except for the fact that the .32 didn't have nearly the stopping power of the .380. The .22 automatic was also without the rear hammer. This weapon was frighteningly quiet. I had to check to see if it had misfired because it was so quiet. However, .22s have no stopping power and require several shots to get the job done. We didn't do any tests on any rifles. If you wish to use a rifle, you will have to make sure of the bullet speed. Any caliber can be silenced if you reduce the bullet speed. In some cases where very large calibers, such as the .45 or .44, are used, it is possible to join two silencers, end to end, to deal with the large amount of gas. Perhaps you can find a larger muffler.

In summary, the .380 without the rear thumb hammer is the best compromise. It is as quiet as the 9 mm., without having to use special shells in it. It has similar stopping power. No need for the 9 mm., .38 Super, or the .32 automatic, if you use the .380 without the rear hammer. The .22 auto is fine if you don't mind using several shots. After all, it is super quiet. The same silencer was used on the 9 mm., the .38 Super, and both .380 automatics. All of these weapons have the same bullet diameter.

#### BACK TO THE ACTUAL CONSTRUCTION

We selected the .380 automatic as our most popular model, since it can be used on the 9 mm., .38 Super, and the .380. The .22 is our second most popular because it is super quiet, even though it requires several shots for effective stopping power. For the .380 silencer we chose a 1/2 inch O.D. piece of plumbing pipe, 8 inches long, and threaded 1 inch on each end. The plumbing pipe had an internal measurement of .345 inches. This matches the internal measurement of .343 for the gun barrel, itself.

We drilled 3/16 inch holes through both walls of the pipe, starting at the threads and continuing to the other end. Make sure to drill only the portion of pipe between the threaded portions. Do not drill the threaded ends themselves. The holes should be spaced every 1/2 inch.



After doing that, turn the pipe on its side so that its undrilled face or side is facing you. Drill this side the same way. Drill all the way through both walls at 1/2 inch intervals, the length of the pipe. Be careful not to drill the threads themselves. This second set of holes should be perpendicular to the first set. See the illustration on the next page. Note that the first and second set are perpendicular.

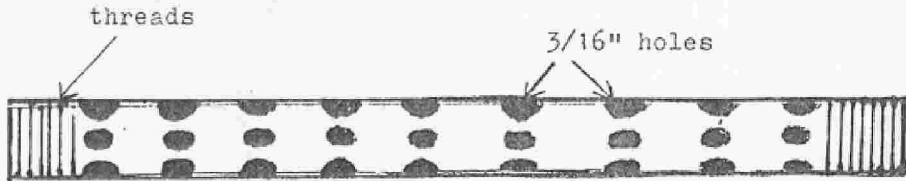

The lawn mower muffler itself was drilled through the center of the coin-shaped disc with variable sized bits, until we carefully approach the size of the plumbing pipe. The plumbing pipe is approximately the same size as a 1/2 inch drill bit, but be careful, the plumbing pipe must fit snugly through the coin-shaped disc. Do not oversize the hole in the disc. Check as you go with the pipe to insure that you don't over drill the disc. If you over drill, too much gas will escape the baffles and the silencer will not be as effective. If you under drill, you will end up forcing the plumbing pipe through the disc and this may break the tack-welds holding the disc in place. Snug is enough.

Once the 1/2" pipe is fitted snugly through the coin-shaped disc, it is time to remove the pipe from the disc so that you can fit the 1/2" to 1" adapter onto the 1/2" plumbing pipe. This adapter connects the 1/2" pipe to the 1" inlet neck of the muffler. Screw one end of the 1/2" plumbing pipe through the wide end of the adapter until it extends out the small end of the adapter by 1/2".

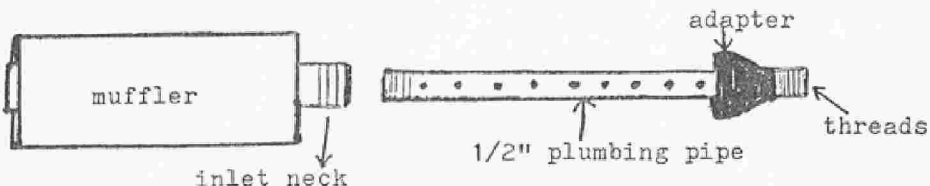

Now insert the long end of the 1/2" plumbing pipe through the inlet side of the muffler, through the hole in the center of the coin-shaped disc, until the wide mouth of the adapter touches the threaded end of the muffler body. Use Locktite Stud and Nut Retainer and screw the adapter as tight as you can onto the threaded end of the muffler. Use a pipe wrench, vise, vise grips, pliers, or even an oil or filter wrench if you have to. Tighten it, but be careful not to collapse the body of the muffler with too much force. Some protective cloth or tape around the muffler will keep your tools from

scarring up the muffler. Once the adapter is tightened onto the muffler, further seal the threads at the big mouth end of the adapter with Super Glue, where it attaches to the muffler.

Get a metal soft plug from your local auto parts dealer. You will need a soft plug approximately 1 and 1/4", outer diameter. Drill a hole through the center of the plug. Slowly and carefully enlarge the hole, until it fits snugly over the exhaust end of the plumbing pipe and the muffler body ridging lip. Get an end cap made of forged steel from your local plumbing supply store. This end cap is for the threaded exhaust tip of the plumbing pipe. It will be for 1/2" plumbing pipe. Screw the end cap onto the pipe end.

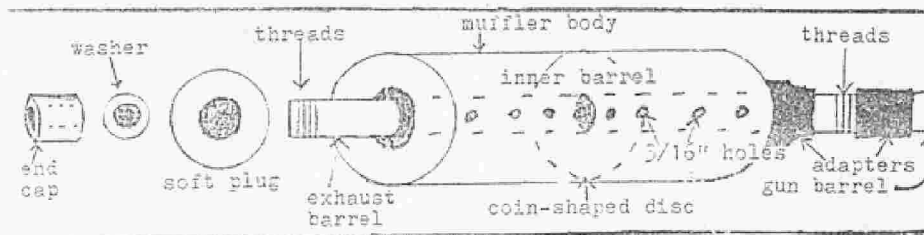

Run a rod, pencil, drill bit, or anything that is long enough to reach from the inlet side of your silencer through to the end cap attached at the exhaust end. Whatever you use should fit snugly in the barrel inside your silencer so that you will be able to align and find the center of the end cap in relationship to the barrel itself. Whatever you use, turn it several times, while forcing it against the end cap, so that it leaves an impression that will determine the center in relation to the barrel. We used a metal pushrod from a car that fitted the barrel snugly and was long enough to reach through the silencer to the exhaust end and mark the center of the end cap.

Once the end cap is marked, remove it. Now that it is removed from the exhaust end, it is easy to drill it at its marked center. Start with a 3/16" bit and proceed slowly and carefully. Drill into the very center of the mark you made on the end cap. Enlarge with various bits until you get a tight fit when you insert the backwards end of a 21/64" drill bit as a measurement tool for clearance.

Secure the soft plug, that you drilled earlier, with epoxy ribbon. It simply fits over the exhaust tip and against the muffler body. Use plenty of epoxy to make sure that there are no leaks where the soft plug touches the muffler body. If there is a gap or any space where the barrel and soft plug meet, epoxy that too. Place a small washer over the soft plug and force it down on any epoxy that may be there and the top of the soft plug. The washer should fit snugly onto the exhaust end of the plumbing pipe.

Place the end cap, that you drilled the hole in, onto the exhaust barrel and use Loctite Stud and Nut Retainer and tighten it down. Now go around the end cap, the soft plug,

and the washer with Super Glue to seal any cracks or leaks.

Let everything dry for a couple of hours, then blow pipe or cigarette smoke through one end while you hold your finger over the other end. If you see any smoke leaking, patch the leak with Super Glue. A 1/2" to 1/2" pipe adapter will screw to the inlet side of your silencer. All that you have to do, then, is to thread your barrel of your gun and screw it on. If you donot have an external barrel on your gun, that you can thread, then you must use a barrel extension or another barrel or possibly an adapter.

Any caliber can be used, so long as you are cautious about the bullet speed. In addition to that, you must find piping close to the diameter of the original gun barrel. In addition to that, you should also know that, whatever the caliber of the gun, always make the end cap of the silencer .030" smaller than the actual gun barrel. Thus causing a pinching effect on the tip of the bullet as it goes through the end cap of the exhaust barrel of the silencer. This pinching prevents gases from escaping around the end of the bullet, out the barrel, and making noise. The pinching causes the silencer to be temporarily sealed and forces the exhaust gases outwards, into the baffles of the silencer. Silencer mufflers can be doubled to handle the most extreme of situations and calibers. A larger muffler can also be used.

All parts are available from your local plumbing supply and automotive parts stores.

## SCALPED ON THE PLAINS

*Harper's Weekly, Nov. 7, 1857*

A Red Bluff paper tells the following thrilling story: "An instance of the most remarkable fortitude and heart-rending cruelty we ever heard of, is related to us by a black man by the name of Scott, who has recently arrived here from Missouri, by the way of the Plains. He informs us that, a short time before he arrived at Stony Point, on the Humboldt River, the Indians attacked a train of six men, one woman, and a child. The men were all killed but one, who made his escape. The child was also killed, and its mother shot in several places with arrows, scalped, and left for dead.

"All the while they were scalping her and stripping the clothes from her body she was perfectly conscious of what they were doing, but feigned death, and let them tear the skin from her head without even giving signs of life, knowing that if she did they would either dispatch her at once or take her into hopeless captivity. At one time, when they had left her for a moment, she ventured to change her position, in order, if possible to relieve herself from the uncomfortable posture in which she was lying, but on their return they very soon discovered that she had moved; and, for fear that life might not be extinct, they took hold of the arrows that were still sticking in her body, and worked them about in the wounds, and pushed them deeper into her flesh, and stamped upon her with their heels.

"All this she endured without uttering a groan, or drawing breath that could be perceived by the savages, and in that condition was left as food for the wolves. Fortunately, however, a train came along before she had lain long in that condition, and dressed her wounds and brought her along with them; and not the least remarkable fact attending the whole matter is, that she is fast recovering from her wounds. Her head, we are told, is nearly well, and the arrow-wounds doing better than any one expected."

## FAMED POISONERS OF ANCIENT DAYS.

Famous poisoners of ancient days seem to have reaped as great a harvest as do the patent medicine manufacturers of the present time. Like them, their success was in the credulity of the people. There were those who sold the wonderful poison rings of Pompeii, whose touch to food or drink, they claimed, was sufficient to cause death. There was the preparation of arsenic, tasteless, colorless, odorless, that might be smeared on one side of a knife with which a peach was cut, the poisoned half being given to the victim, while the murderer could eat the other half with impunity. Then we are told of the drinking cup that turned wine into venom, and the looking-glass with the magical power of killing any one who looked into it. There were poisons whose action could be timed to a nicety; poisons whose evil influence would be exerted not immediately, but after months or even years; poisons that left no trace, and many others. It was to the interest of those who pretended to deal in poisons to magnify the wonder-working qualities of their remedies. Their credulous customers could make no public reclainer if the drugs failed to accomplish their purpose. Like the vendors of the wonderful drugs that in our day are sold so commonly to change the course of nature or to develop the form, the presumed poisoners of former generations had little to fear from legal prosecution if their recipes proved unavailing. Such stories, says the Journal of the American Medical Association, are like the fairy tales, for advertising purposes, of the remedy that put in coffee cures the tobacco habit without the victim's knowledge.



## POPULAR MECHANICS

July, 1937

# "HUL-CHE"

*a Re-discovered American Sport*

By  
EARL B. POWELL

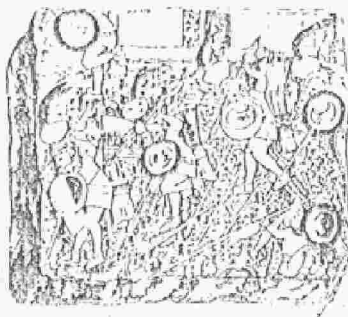

REMINISCENT of the ancient Mayas who could throw a 4½-ft. javelin with the speed and accuracy of a bullet, hul-che is the rediscovered method of throwing short spears and darts for sport's sake. Copied from specimens dredged from the Sacred Well at Chichen-Itza, the dart and thrower shown are made of hardwood, shaped and highly polished.

For an ordinary man-sized throwing stick or hul-che, such as shown in Fig. 3, take a round piece of hardwood about 7½ in. in diameter, or it may be elliptical in cross section, say about 1 by ¾ in. Set the beak or hook piece, Fig. 4, in the end edgewise and the crossbar, Fig. 5, which is about 2½ in. wide, is set in a slot near the other end and is fastened with wooden pins and glue. It is a good idea to lash the stick as shown in Fig. 6 to avoid splitting. Slot the end at right angles to the cross-piece and set in the beak piece in the same

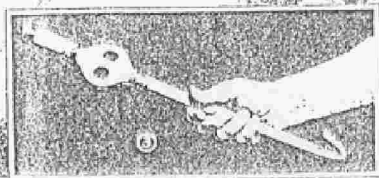
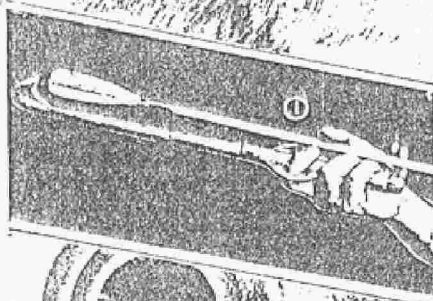

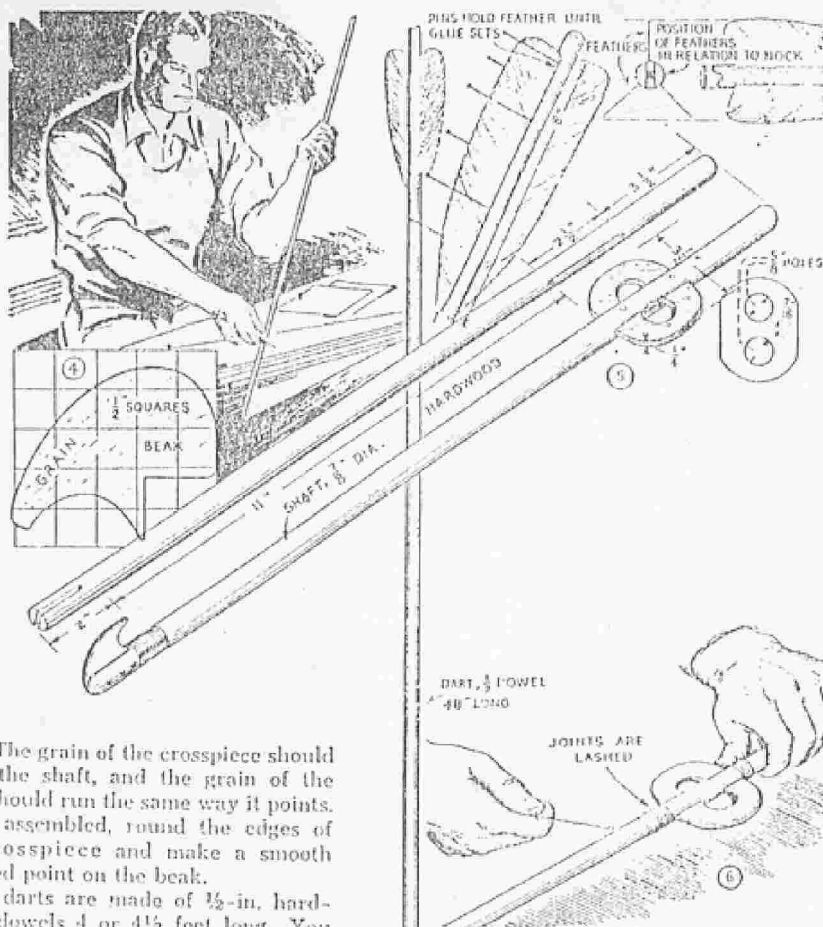

way. The grain of the crosspiece should cross the shaft, and the grain of the beak should run the same way it points. When assembled, round the edges of the crosspiece and make a smooth rounded point on the beak.

The darts are made of  $\frac{1}{2}$ -in. hardwood dowels 4 or 4 $\frac{1}{2}$  feet long. You can use regular arrow heads or ferrules of tubing on one end for heads. A semi-circular depression is made in the other end to take the hook of the throwing stick. Or, you can slot it in the same way an arrow is slotted for a nock. In this case, one side of the slot is cut down about  $\frac{1}{4}$  in. to take the hook. In feathering the dart, set one feather in line with the slot and space the other two equally around the dowel. The feathers should be about 6 in. long, very high and as stout as you can get them.

To throw a dart, take a throwing stick in the right hand with the palm up, putting the first and second fingers

through the holes in the crosspiece. Wrap the third and fourth fingers firmly around the handle with the thumb hanging loosely. Then engage the end of the dart with the depression or slot, laying the shaft on the nails of third and fourth fingers and fold the thumb over the shaft

snugly, but not tense, as shown in Fig. 1. Now swing the right hand up and back so that it is over your right shoulder as in Fig. 2. With your body balanced on your right foot, use the left leg as a counterpoise, and bring the right hand forward with an overhand swoop, at the same time lunging forward and twisting the body so that the right shoulder comes to the left. This following through with the hand makes throwing accurate. With a little practice, you will be able to hit the target at 60 yards, time after time.



# The Little Top

JULY, 1946

# That Aims a Gun

How the gyroscope, once just a curious scientific toy, has been harnessed to guide ships and planes and make their fire deadlier.

A TINY, fast-spinning wheel that used to be nothing but a child's toy has been transformed overnight into one of the deadliest of our war weapons. The gyroscope has finally come into its own, and we are putting

full use of its uncanny power. It virtually saved the battleship from the junk pile by giving us gunsights that could knock down Jap planes before they got close enough to dive-bomb or launch torpedoes. It made the devastating B-29 raids on Japan possible without fighter escort. The Superfortresses can take care of themselves because of two spinning wheels no bigger than a baby's fist that give their guns accuracy never known before.

Drawings by STEWART ROUSE

## WHAT IS A GYROSCOPE?

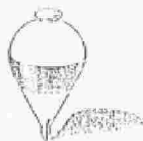

A spinning top is a simple gyroscope. Obeying the natural law of inertia, it always maintains its own steadiness in space.

Put that spinning top in a ring, with bearings at top and bottom, and you have the basis of a gyroscope.

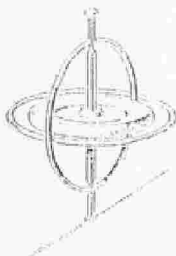
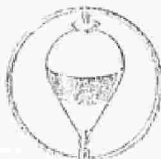

In this familiar gyroscope toy, a top has been given free balance. This plaything inspired Ulmer Sperry's work.

For practical use, continuous rotation is needed. The rotor can be part of an induction motor.

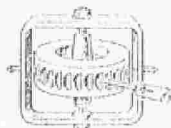

... or it can be kept spinning by a jet of air blown against its notched rim by a vacuum created inside the instrument.

The turning point in the Pacific war came when U. S. "Battleship X" virtually annihilated a force of attacking Jap planes on October 26, 1942. That was the first major tryout of the new gunsights and the first clear-cut victory of seapower over airpower in many a day. When the reports of that battle came in, it was apparent that something new had been added since Jap planes sent the mighty British warships *Repulse* and *Prince of Wales* to the bottom in a few minutes. The Navy was so thrilled about the new gunsight and attached such importance to it that even the name of the battleship was kept a secret for a long time afterward. Now we know that it was the *South Dakota*, and the Navy has also revealed the fact that its ability to smash attacking planes was due to the gyroscope sights newly installed on its anti-aircraft guns.

Many thousands of the gunsights have been made since then. They are now in control of practically all American and British naval anti-aircraft guns, and they have shot down Jap planes by the hundreds. That is one reason why our Navy was not afraid to go within range of Japanese land-based planes. The Jap navy was chopped down to near impotence by a succession of defeats. Some of these were administered by our surface ships and some by our planes, but in either case the superior protection of our fleets against attack from the air gave us a mighty advantage. Jap pilots knew it was literally suicide to attack our ships, but they kept trying. Very few lived to try again, although a few got through to inflict damage on light naval units.

American inventive genius has given us these important new weapons, and several

**"RATE GYRO" COMPUTES LEAD**  
 for anti-aircraft guns. Pulling a brake on a gyroscope makes it a "rate gyro," so that the amount of its precession (tilt to resist turning) is determined by the rate at which it is moved from its original plane of rotation. In the model below, the arrow represents line of sight to the target; the rod, direction in which gun barrel is pointed and path of the bullet.

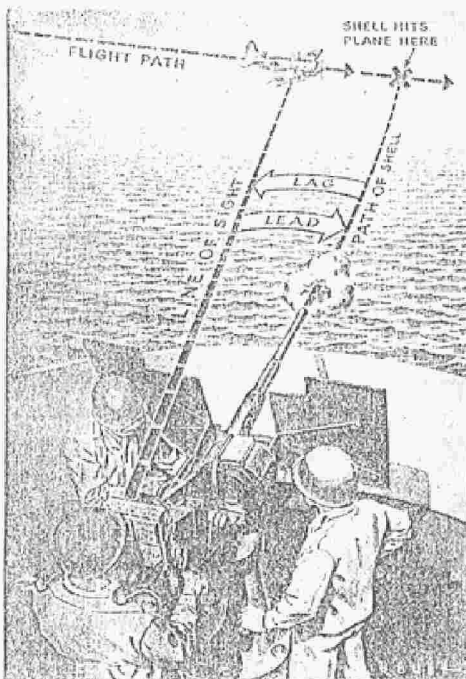
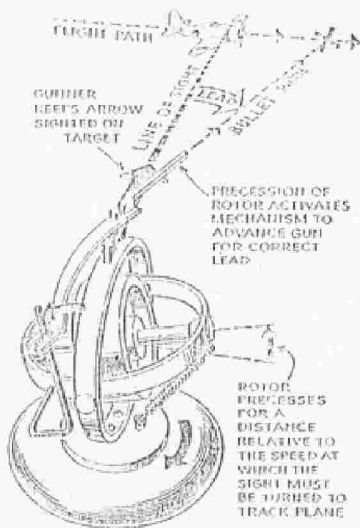

As the gunner follows the target with his sight, the precession of the gyro causes the gun barrel to "lead" the enemy plane. The faster the gun is swung, the greater the precession becomes and the more the barrel leads the sight, so that shell and plane reach the same point simultaneously.

others, by harnessing the peculiar power that scientists have long known to reside in the spinning gyro wheel. The principle of the gyro is a simple one and as old as the world itself. The inertia of a spinning mass is what makes a top stand upright, and this

is the basis of all gyroscope uses. Though scientific men have known this for more than 100 years, they made no practical use of it until early in this century. Their first use was in a weapon of war, the torpedo, as a stabilizing agent.

**GIMBAL RINGS ALLOW ROTOR TO SWING FREELY**



Starting with a well-balanced rotor, an inner ring is provided for its bearings. X-X is the spinning axis.

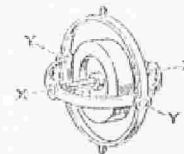

A second ring is attached by free-turning bearings. In it, the rotor can swing on axis Y-Y, at right angles to axis X-X.

Only a half ring is needed to complete the gimbal mounting. On this third axis, Z-Z, the inner rings turn, enabling rotor to swing in any direction. Ball bearings are used in all axes of the gimbal rings.

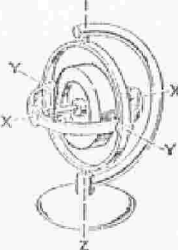

Tolerance of some elements had to be as small as one ten-thousandth of an inch to make the gunsight accurate. Months of diligent effort under high pressure brought success. Engineering brains and ingenuity had written another brilliant chapter in the history of American invention.

Almost ridiculously small are the vital parts that give this gunsight its ability to shoot speeding planes out of the air with regularity. The rotors—two to each sight—are two inches in diameter and weigh less than a pound each. They are turned by an air jet shot into slots around the perimeter. At a speed of 10,000 to 11,000 r.p.m., they have the necessary inertia to remain independent of all influences except those deliberately and carefully brought to bear upon them in order to perform the function of

giving the gun a correct lead in front of the moving target.

When a spinning wheel, nicely balanced, is properly hung in gimbal rings, it is entirely independent of all its surroundings—as if it were a thing apart from the earth. Its own inertia is its only law, but that law is absolute. All gyroscopic instruments obtain their peculiar abilities from calculated efforts to make the spinning rotor violate this law, a thing the scientists know it will not do. What the gyro does to preserve its inertia is to "precess," that is, to move at a 90-degree angle away from a force applied against its axis of rotation. Since this movement can be counted upon absolutely, the inventors employ it to do whatever is desired—to open and close valves, apply and cut off electric current, and so forth.

The type of instrument employed in the gunsight is called a "rate gyro." That is,

it is a gyro controlled by springs so that the faster it is made to precess, the greater the force it exerts on the springs. In the gunsight, this force is determined by the rate of movement given by the gunner to the gun in following the target. Fast movement gives greater force than slow movement. This force is instantly transmitted to a mechanism that offsets the line of sight from the line of the gun bore so that when the gunner is aiming his sight at the target, the gun is actually pointing ahead of the target by the right amount so that the enemy will fly into the bursting shell. All the gunner has to do is to follow the target steadily with the sight and pull the trigger.

When the B-29's were being designed for the special mission of long-range bombing raids on Japan, it was obvious that they would have to go without fighter escort, so the efficiency of their guns in protecting them from enemy fighters was a matter of greatest concern. Gen-

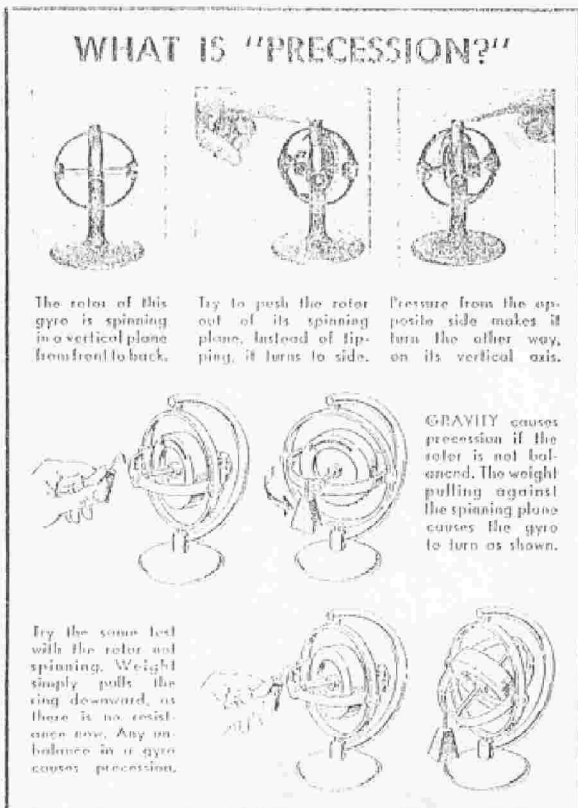

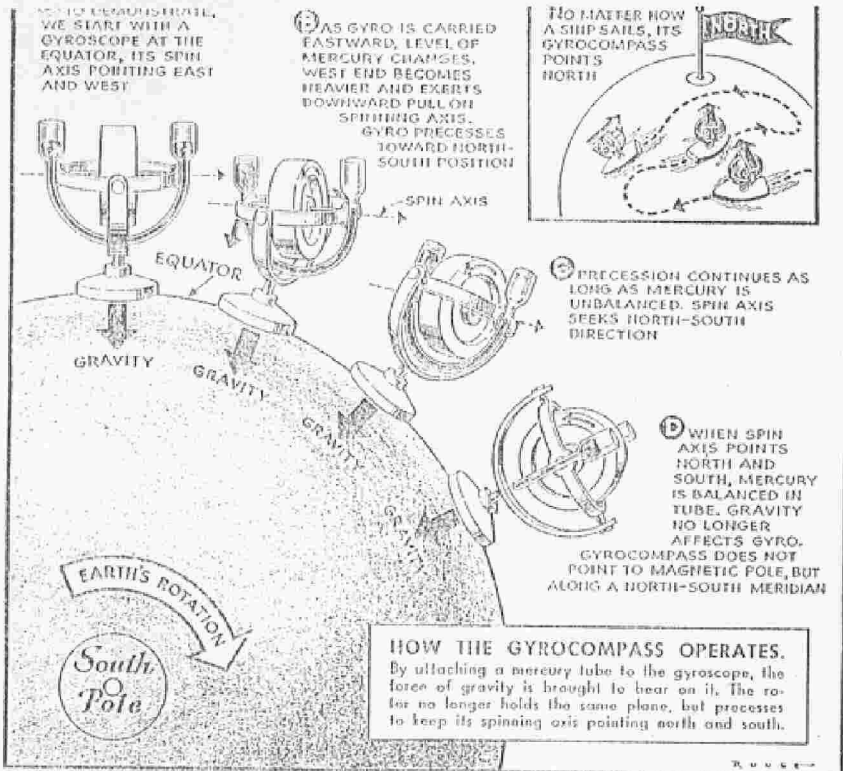

**SPERRY GYROCOMPASS** uses a 10-inch, 55-pound rotor, seen in lower part of cutaway view at right. A slender tube extending around the rotor holds 12 ounces of mercury. Such instruments are now used on most big vessels, including warships.

**AN EARLY EXPERIMENT.** The familiar gyro toy is used by Elmer Sperry in the old photo below to show how he applied outside forces to make it a compass.

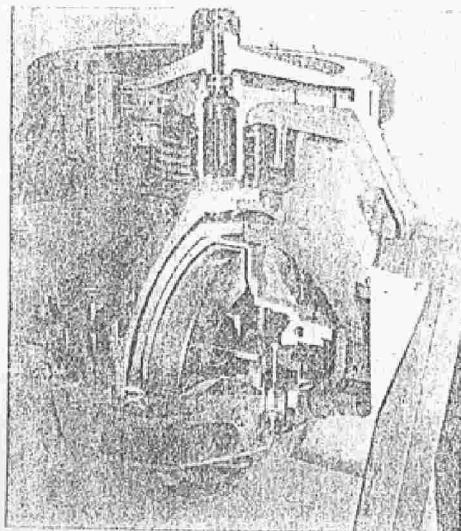
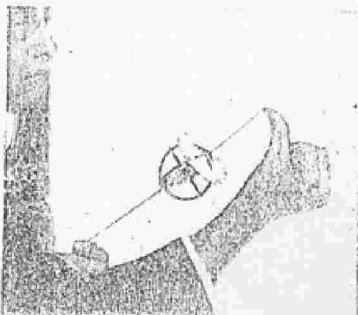

eral Electric was given the vitally important task of designing the controls for these guns. The central gunnery system invented for this special purpose is a combination of electronic, mechanical, and gyroscopic devices that has spelled disaster for the Japs. (P.S.M., Feb. '45, p. 38.) Here again, the prodigious task of computing the speed of an attacking plane relative to that of the bomber was turned over to two tiny spinning rotors, electrically driven in this case. It makes no difference to these magical wheels whether the speed of the fighter must be added to or subtracted from that of the Superfortress; it is done instantly. The gunner sits in a warm, pressurized cabin, follows the target with his sight, and pulls the trigger that may fire one, two, or three sets of guns at once. All calculations are automatic and instantaneous. The guns lead the target by the correct angle at all times.

These are the defensive uses of the gyroscope in war—important enough, surely, but only a fraction of the gyro's contribution to winning this war. Gyros are on the offensive, too—in planes, tanks, ships, submarines, and torpedoes.

When the big bombers—the B-29's and all the lesser ones—arrive over their target area, the whole ship is turned over to gyroscopes that make the automatic pilot

work. The bombing runs must be straight and true, and this is managed by the spinning wheels more accurately than any human hand could do it.

And now the bombing run is on; the vital moment has arrived for which the great machine and its crew have made the perilous journey. Again the gyroscope is called upon to make the bomb hit the mark. The Norden bombsight is put to work—and two more of the spinning wheels are doing their stuff as essential parts of that famous weapon. (P.S.M., June '45, p. 70.)

There has been a lot of controversy about the relative potency of our tanks as against those of the enemy, but in one respect there is no question of our superiority in this department: our tanks can shoot straight on the run. Here, again, the secret is the gyroscope—just one 14-ounce rotor that holds the biggest tank gun on a true horizontal line, no matter how much the tank pitches and rolls over rough terrain. This was an achievement of Westinghouse (P.S.M., Sept. '44, p. 82). General Patton, who ought to know about tanks, gave high praise to the gyrostabilizer in telling how he had been able to beat the larger German tanks for sensational victories. 'The Germans could shoot straight only when they stopped dead, and then they were sitting ducks for targets,

## THE GYRO IS THE BRAIN OF THE SUPERFORTRESS' GUNS

At the left, below, is the central control gunsight that aims the guns of one to three turrets of the B-29 Boeing Superfortress. With its combination of gyroscopic, electronic, and mechanical devices it automatically computes lead angle, gravity, windage, and parallax in a split second. All the gunner has to do is hold his sight on an enemy plane and pull the trigger. At right, separate units removed from the plane show a gunner using the sight while a turret obeys electrical impulses carried by a cable.

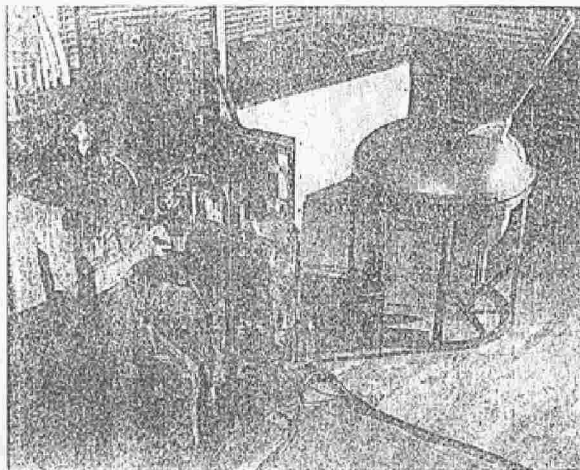
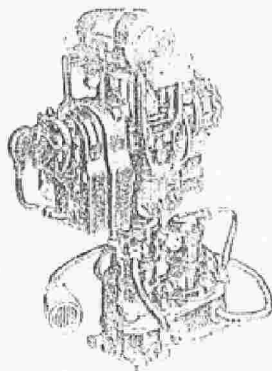

GYRO'S STABILITY IS USED IN AVIATION INSTRUMENTS

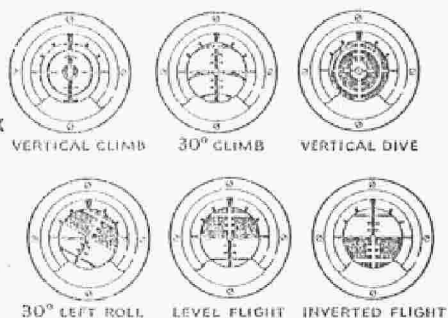
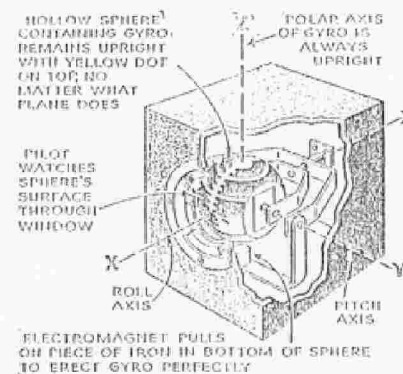
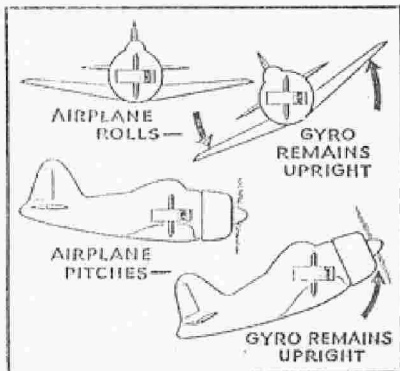
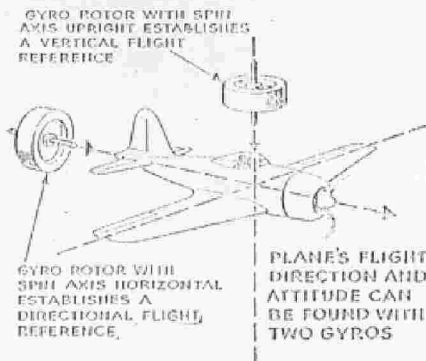

WHAT VARIOUS PORTIONS OF THE SPHERE'S SURFACE MEAN TO THE PILOT WHEN SEEN

ATTITUDE GYRO SHOWS PLANE'S RELATION TO THE EARTH

while our tanks kept on the move, firing with deadly accuracy.

It should be kept in mind that a small gyroscope, such as those in planes, gun-sights, and gun stabilizers, has no great power. A man can move one of these rotors out of its plane of rotation with his hand. What it does have is formidable accuracy when it is nicely balanced and freed from the element of friction to the degree made possible by precise manufacturing methods. The gyro in the tank, for instance, merely opens and closes magnetic valves, an operation that takes practically no power. It is just a matter of making electrical contacts. Oil pressure, kept up by an independent pump, does the work of pushing the gun breech up and down, counteracting every movement of the tank. The gyro tells it when to push and when to pull.

Let's not forget, either, that it is the same meekly gyroscopic power that gives the biggest guns in our fighting ships a true vertical reference at all times so they can fire with accuracy regardless of roll and pitch. This is certainly an offensive use of utmost importance. So is the work of gyros that guide our torpedoes to send Jap ships to the bottom. The gyroscopes in torpedoes did us plenty of damage in the Atlantic, but in the Pacific they have been largely on our side.

And these are not the only important uses we are making of gyroscopes to speed this war to a conclusion. How that our scientists have really tackled the problem of harnessing the gyroscope to man's purposes, there is no telling; what important new services they may find for it in the years to come.

GOLD V. SANDERS.



# A "Bomb Hitler" Game

By DICK HUTCHINSON

POPULAR HOME-CRAFT DECEMBER, 1943

**A**FTER all of the suffering that Hitler has brought upon the world, everyone here in America would like to take a shot at this master criminal. We feel that it would relieve our pent up hatred for this monster if we could hear at least one bomb in his direction.

Here is a simple game that is a lot of fun and all can play. The little time spent in the construction of this new "Bomb Hitler" game will more than compensate you for your effort, and will at least give you a chance to show what you would do if you had the chance.

The floor, or bottom of the box, is made from  $\frac{1}{2}$ " plywood. The opening for the door is sawed out, and the trap door set in as illustrated. This is hinged in place, and a  $\frac{1}{4}$ " strip of any spring metal may be used to throw the door open. A coil spring may be used if desired, however, coil springs are hard to get at the present time.

The floor is cased in with  $\frac{1}{4}$ " boards, which are put together with wire brads.

Coat the surface of the floor with liquid glue, then sprinkle over with fine sawdust. Let dry, then dust off, and paint green, either with oil paint or show card colors. If the latter is used this should be followed with a coat of shellac.

Paint, or stain, the frame to give it a finished look. Outline the figure of Hitler on a piece of the plywood, and saw out.

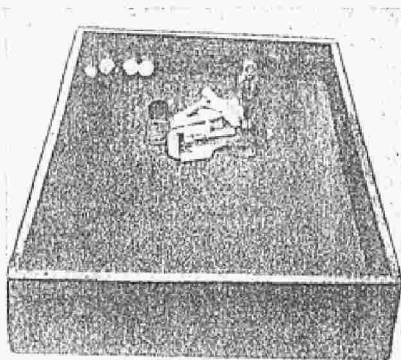

The "Bomb Hitler" game set up ready for a test of your skill at throwing a few marble hand grenades.

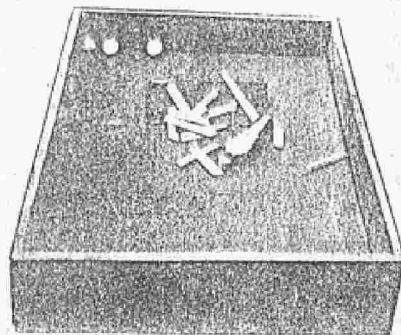

Someone scored a direct hit, in the "Bomb Hitler" game.

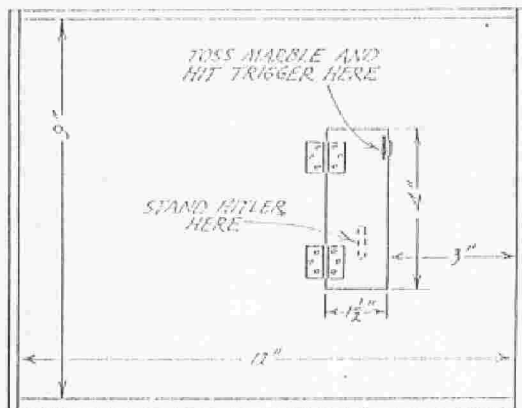

TOP VIEW

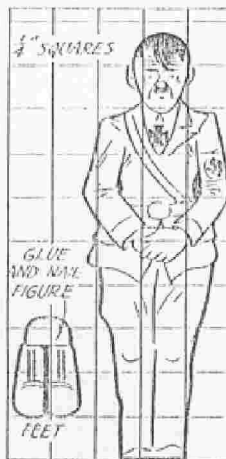
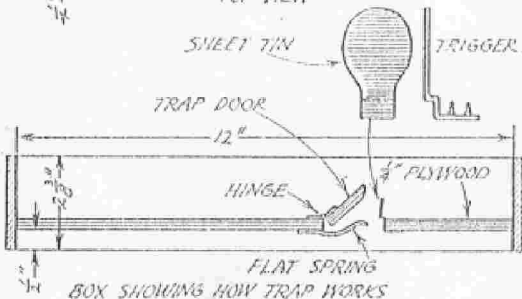

separate piece for the feet is necessary to place Hitler in a standing position. Glue, and nail the feet to the bottom of the legs of the figure representing Hitler.

Paint face a flesh color, uniform an olive gray, and trim in black, include a swastika on the left arm, and a black mustache. This may be done with water colors, followed by a coat of white shellac.

## "BOMB HITLER" GAME

Close the trap door so that the thin metal trigger will hold it down. Place the figure of Hitler in a standing position on the trap door, along with several match sticks or anything that will make it look more like a real explosion when the trap is sprung. Now you are ready to bomb Hitler.

Stand back about three feet from the set-up, and using marbles for hand

grenades, try to hit the little trigger which, when hit, will release the trap door, throwing Hitler and everything that is on the door into the air just like a real hand grenade would do if we were to land one very close to Hitler himself.

German soldiers, guns, etc., may be purchased at any dime store, and may be substituted for Hitler if desired.

+

# Rubber Band Pistol

LOOKS LIKE REAL "GAT"

Popular Science Jan., 1935

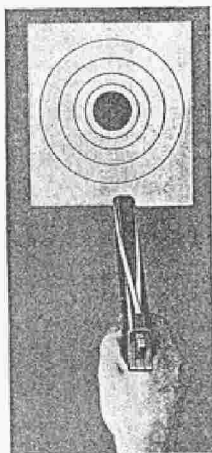
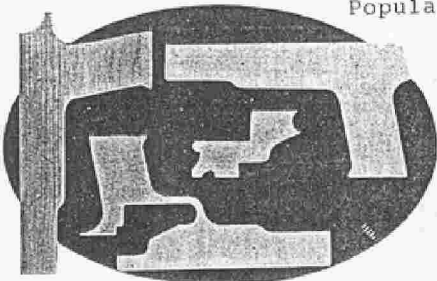

Pulling the trigger moves the hammer back and lets the end of the rubber snap forward



**H**ERE is a wooden automatic pistol that looks like the real thing and shoots rubber bands with surprising accuracy.

Obtain three pieces of clear white pine  $\frac{3}{4}$  by 5 by 10 in. and fasten them together with a few brads. Lay out a full-size plan of the pistol and transfer the drawing to the top board with carbon paper. Saw all three pieces at one time on the outside lines. Then separate them, and from the top and bottom pieces cut away the trigger guard and hammer.

Lay out the combined trigger and hammer on the center piece and saw it out. Also saw out the trigger guard, taking great care not to break it. If the trigger guard is shellacked as soon as it is sawed out, it will be less likely to break. Rub the trigger-hammer combination flat on a sheet of fine sandpaper, thinning it down from both sides so that, when assembled, it will move freely between the other pieces. A small coil spring from a baby battery clip, sold in the ten-cent stores, or from any other source, is used

The pieces that have no hammer or trigger guard form the side plates. Between them is set the piece with the trigger guard. In the opening of this part is placed the combined trigger and hammer. At right is the gun ready to shoot

as shown to hold it in the forward position.

Glue the center section, without the trigger-hammer combination of course, to the right-hand piece and let it dry under a weight.

Now assemble the pistol, attaching the left-hand to the other two with three small screws. Then round, shape, and smooth the weapon to its final form. Give it a coat of shellac and, when dry, sand it to a very smooth finish. Mix a little lampblack with some blue paint until about the color of blue steel and paint the gun. The handle plates may be marked out and painted brown, if desired.

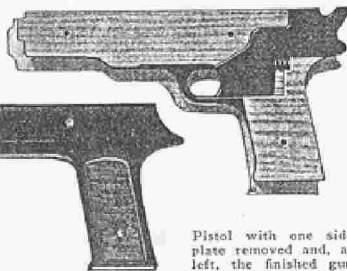

Pistol with one side plate removed and, at left, the finished gun

To load, pull the trigger to raise the hammer and insert the doubled end of a rubber band in front of the hammer. Let the hammer down on it, then draw the other end down over the muzzle end. A pull on the trigger will shoot the band a good distance.—CLARK H. RUTTER.



## BLOWGUN

provides exciting sport and will give you an eagle eye. Its accuracy is unbelievable.

by Bertram Brownold

*Mechanix Illustrated October, 1943*

Dart is propelled by quick, sharp puff.

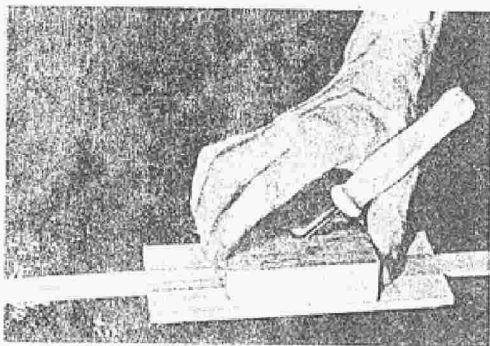

Improvised rabbit plane made with gouge and wood block is used to groove barrel.

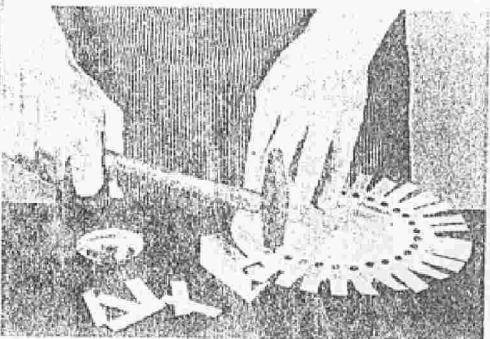

Groove-cutter can be used if desired. Made of plywood, sandpaper, it goes on saw.

**T**HE blowgun, a primitive weapon for warfare and hunting, can be used as the main piece of equipment in a very novel and enjoyable sport.

It is a lightweight tube varying in length from 6' to 10'. Through this tube a dart with a needle-sharp point at its forward end and with a tuft of thistle-down or feathers at the other end is propelled by a blast of air from the lungs of the hunter. The native hunters poisoned the points of their darts, various savage tribes using different poisons including "curare," a powerful vegetable poison, and snake venom.

The blowgun used in the Malay Peninsula is made by smearing resin on the outer surface of a hollow reed and then inserting the reed into a bamboo tube. When the resin dries, the reed and the bamboo form a unit that is light and strong. The reed alone would be too fragile for practical use while the bamboo has too rough an interior. The reed furnishes the necessary smooth bore.

Another method used by the savages in constructing blowguns is to scrape a groove in each of two slim straight-grained pieces of wood of suitable length. The two pieces are then bound together forming a tube. The scraping tool used is the tooth of an animal mounted in a wooden handle.

With modern tools at his disposal the civilized craftsman can make a blowgun far more quickly and easily than can the savage, and his will be more accurate also.

Cut a half round groove lengthwise down the center of the flat surfaces of each of two

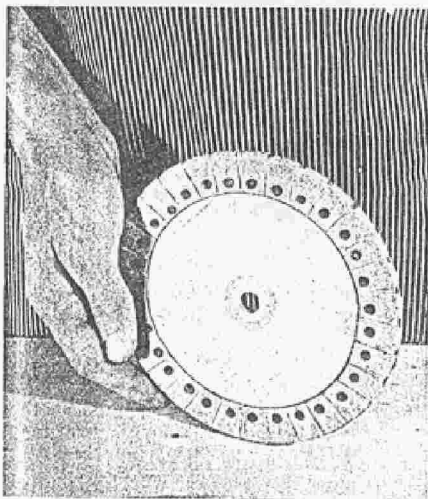

Tack sandpaper to a plywood disk.

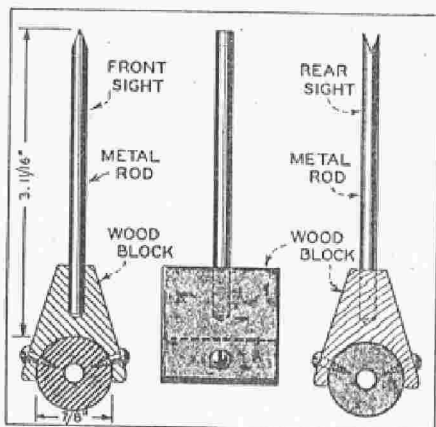

The sights are made as shown above.

6' pieces of 1" half-round molding. Glue the two flat surfaces together, taking care that no glue obstructs the central tube thus formed. Each groove should be  $\frac{3}{8}$ " deep and  $\frac{1}{4}$ " wide so that the tube is  $\frac{1}{4}$ " inside diameter. Sand the bore of the groove to a glassy smoothness with fine sandpaper wrapped around a dowel stick. This is important because the darts will catch on any rough spots.

The grooves can be cut in a number of different ways. If a circular saw or drill press with the correct routing attachment is available, cutting the grooves is the work of but a few minutes. If the

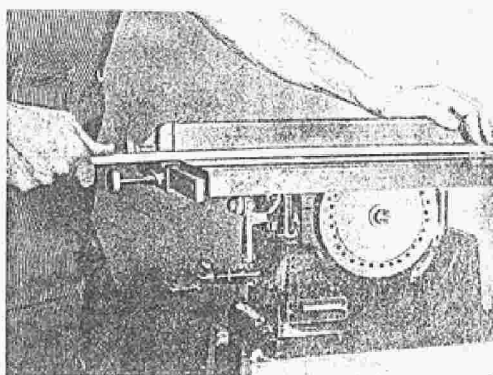

Use groove-cutter on circular saw.

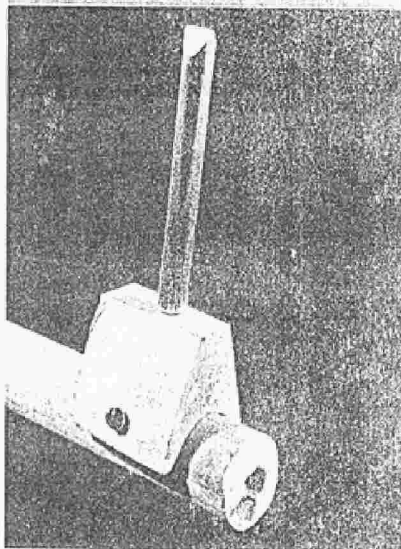

Forward sight is placed one inch from muzzle. Needle dart is shown below. Darts can also be made from dowels, with points rounded.

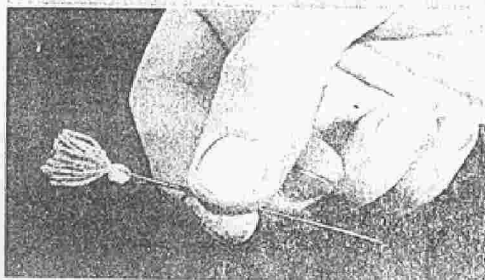

craftsman does not possess these tools or in view of war conditions finds it impossible to buy them, he can improvise others that will do the job handily and which will also be useful for similar jobs in the future. One such improvised tool is a rabbet plane made by forcing a gouge through a hole drilled at the correct cutting angle in a hardwood block. Another is a groove-cutter made by tacking strips of sanding cloth to a circular disk of plywood in the manner shown in the photos. Such an improvised groove-cutter can be used on the spindle of a circular saw in place of the blade.

A word or two about the construction of these improvised tools may be helpful. For the groove-cutter cut a sufficient number of small pieces of sanding cloth about  $\frac{1}{2}$ " wide and 2" long. About forty-two of them are needed for a disk having a diameter of 7". Tack them to the plywood with tacks long enough to penetrate about  $\frac{1}{8}$ " on the other side of the plywood, first having applied glue to the disk. Then turn the disk over, apply glue to the other side, fold the slips of sanding cloth around the edge of the disk, pull them tight and press them down on the points of the tacks which are then clinched.

The improvised rabbet plane has screws to its under surface two strips of wood spaced so that the flat surface of the half-round molding can slide between them. These strips act as guides, keeping the gouge centered on the molding. Set the gouge fine so that it will cut only a very shallow groove and, when the cut is finished, set the gouge to make a slightly deeper cut and so on until a groove of the desired depth is achieved. Setting the gouge is accomplished by tapping it through the hole with a mallet when a deeper cut is desired, and pulling it back with a pair of pliers when it is desired to reduce the depth of the cut. The shavings come up through the hollow

of the gouge and it will cut better if this space is kept clear with an awl.

To make the darts use ordinary sewing needles about  $1\frac{1}{2}$ " to 2" long. Thread a few strands of knitting wool through the eye of the needle, trim

the strands evenly so that they make a tuft about  $\frac{3}{8}$ " long and bind the tuft in place with strong, light thread. Be sure that the tuft is loose and easily compressible otherwise it will not slide easily in the bore of the gun. If it fits the bore too snugly clip away some of the wool with scissors. In making a number of darts use wool of several colors so that when using the gun each participant will have darts all of one color. This facilitates scoring on a target.

Sights can be added to the gun and they will be an aid to accurate aiming, although the primitive originators of the weapon apparently knew nothing about sights. Use two pieces of scrap-metal rod each about  $3\frac{1}{2}$ " long and set each piece in a block of hardwood. File the upper end of the forward sight to a point and file a V in the upper end of the rear sight. Fix the gun in a vise and shoot a dart into a board placed about 6' or 8' from the muzzle. Then line up the sights on the dart and screw the blocks to the gun. In doing this be sure that the trajectory of the dart has been flat. It will be found that the darts have a tendency to drop about 1' in every 25' of flight. Thus in shooting, it is necessary to aim above the mark, and practice will tell how much. The forward sight is placed about 2" from the muzzle, and the rear sight is placed about  $1\frac{1}{2}$ " from the other end of the gun. When the gun is at the mouth of the user, the tips of the sights should be at the level of his eyes.

Taper the rear end of the gun for convenience in blowing.

Using the blowgun is an interesting and fascinating sport. Practice will soon teach the marksman how to gauge and allow for wind direction and velocity. It will be found that best results are gained by blowing a short, sharp blast of air.

It is suggested that any target used be pinned to a large sheet, or tacked to a wall. The reason for this is obvious. If it is tacked to a pole or tree, darts that miss the target will fly beyond it and be hard to find.

DECEMBER, 1940

POPULAR MECHANICS

## Air-Powered Machine Gun Fires 10,000 Shots a Minute

Instead of firing its bullets with noisy explosions, a silent machine gun, invented by William B. Hale and Durand Beam, shoots with compressed-air power. In recent tests the rifle, which resembles a sub-machine gun, discharged 10,000 shots a minute, reducing three-inch oak planks to kindling and turning airplane armor plate into steel mosquito netting. As firing starts, the barrel cools, instead of heating, due to use of air as the propelling power.

*Silent rifle powered by compressed air instead of gunpowder is shown at right with steel target riddled by bullets in test*

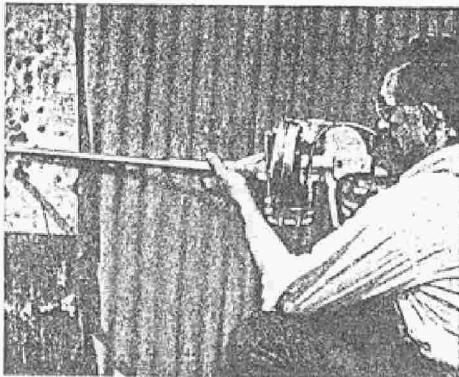

## THE SLING

By Richard W. Williams



The sling is one of man's oldest weapons. It is so simple to use; yet so misunderstood by most people.

The best way to demonstrate its principle is to imagine you were throwing a baseball. As you let go of the ball, consider that it would have gone several times as far and with much more force.

Now you know how to use the sling, which is merely an extension of your arm. But people persist in thinking the sling must be swung around the head, with the quite logical apprehension that the pouch and its missile will crack the stinger's own skull.

Don't forget David swings for effect and no mist. In actuality he is actually hurled. In reality, it's just the ordinary overhand throw that works best.

With one cord tied around the wrist and the end of the other held in the hand, the pouch simply opens as the end of the other cord is released. The force often makes a sound like the crack of a whip. And if a stone is the projectile, it will often hiss as it goes through the air.

How long your sling should be depends on how tall you are. Hold the sling down by your side

with both cords as if ready to use. The pouch should reach about mid-calf. That's a good rule of thumb but not mandatory. You can make it longer or shorter, depending on what feels right to you. Actually, the cords can be as short as six inches if you have a naturally hard throw in the first place.

The shorter the sling is, the easier it is to control. I suggest you begin practice with a relatively short sling and lengthen it as you grow proficient. At any rate, you'll soon find that a stone will hit with deadly force with a bit of practice. Once you've got the hang of it you'll wonder why you hadn't learned this deadly skill sooner.

## Mousetrap Supplies "Firepower" for Simple Toy Cannon



In assembling this toy cannon, which uses shells cut from wooden dowels, you won't have to worry about fitting a trigger and spring mechanism, as firepower is provided by an ordinary mousetrap. After

screwing the trap to a solid wood base, a suitable barrel is turned, bored and mounted so that the trap jaw strikes the center of it when sprung. Loading is accomplished quickly by setting the trap and inserting a shell, leaving the end of it project slightly as shown. Then the trigger is pressed to spring the trap and "fire" the cannon.

—Thomas M. Stradley, Jeffersonville, Ind.



# Debunking the Debunkers

By E. B. MANN

THE AMERICAN RIFLEMAN  
JANUARY, NINETEEN FORTY-FOUR



IT IS THE FASHION to doubt. "If you believe it you're naive," might well be the slogan of our time, and professional cynics have exploited this fad of upsetting respected appercarts by "debunking" (at so much per word) everything from Santa Claus to spinach, including such national figures as George Washington, Abraham Lincoln—and the old western gunman.

It is a healthy trend, within proper limits. Much worthwhile fact is hidden or distorted by lies, and any delving that reveals the truth is good. But honest debunking leaves the truth untouched. Too many "debunkers" forget that! They forget that not all history (or legend either) is bunk. Their object is to shock; and if the truth is not sufficiently shocking, they doubt that too! Or, worse still, they alter it.

To doubt everything is just as naive as to believe everything. And the man today who believes the grifter who offers to sell him the Brooklyn Bridge is no more naive than the man who says, "The old western gunman is a myth!" and tries to prove it by the specious argument, "I can't do it, therefore it can't be done!"

The old western gunman is no myth. His skill was real, and proof is available to any who will seek it.

Why, then, do men who should know better, even men whose own skill with guns has earned them national fame, seek deliberately to discredit the men who are the heroes of the boys and girls whose interest must be maintained if the game is to live? Why label "impossible" the skill of those old-time gunners—when there are men living and shooting today who can equal or surpass anything they ever did or anything any sane person ever claimed they could do?

I don't know why they do it—but they do. Witness two articles, taken more or less at random from the bulk of such material published in recent years: "Gun Philosophy," by Chauncey Thomas, and "Wild West Gunmen Were Not So Hot!" by Charles Askins, Jr.

Mr. Thomas says, "One of the most widely-circulated myths of the frontier is that of the 'two-gun man'; the man with two guns which he used simultaneously. Such a man never existed."

Mr. Thomas pins the lie also on "fanning"—that much-

"There were no second prizes, no re-entry rules for those old-timers. A man shot straight and fast—or else! Alibis had no weight; the pallbearers carried that. It was the day of the quick and the dead. The quick lived; the others went to Boothill."

discussed and frequently-misunderstood business of holding a single-action revolver in one hand and firing it rapidly by knocking the hammer back with quick brushing blows of the palm of the other hand. Mr. Thomas says, "Fanning is a myth. I've written this subject up thoroughly and posted a certified check of \$1,000 reward for anyone who could demonstrate it. . . . In the same class come shooting from the hip and shooting by instinct. . . . All ways of shooting either rifle or six-gun other than by aiming through the sights are pure bunk."

Beware the man who makes flat, categorical statements! A man once looked at a giraffe and said, "I must be crazy! There ain't no such animal!" He may have been crazy, but there are giraffes. And the two-gun man did exist and does exist today, Mr. Thomas to the contrary notwithstanding.

James Butler "Wild Bill" Hickok was a two-gun man. So was Bill Longley, John Ringo, John Wesley Hardin, Billy the Kid, Sam Bass, Dallas Stoudenmire—to name but a few. So was Wyatt Earp.

Earp was one of the great gun-fighting peace officers of the Old West. He served in many of the wildest and toughest of the rail-end, trail-end towns of Kansas, and in Tombstone in its heyday. He fought with and against the best (and the worst) of that gun-toting era and was one of the few of his kind who lived to die of old age in a less dangerous decade. He knew the great gunmen of that day, good and bad; and he lived so recently that his testimony can be taken practically verbatim.

Earp says, "I wore my pistols in open holsters, one on each hip. . . . They wore two guns, most of the six-gun toters did; and when the time came for action they went after them with both hands."

Perhaps, in fairness to Mr. Thomas, I should quote Earp a bit further. Perhaps Mr. Thomas pinned his

statement on the one word, "simultaneously." If so, Earp says, "They didn't fire them simultaneously. Some men could shoot equally well with either hand and in a gun-play might alternate their fire. Others exhausted the loads from one gun, then shifted guns."

Two guns can, however, be fired simultaneously, to hit the same or even widely separated targets. That is a subject we'll take up a little later. . . . But the old-timers did wear two guns; and they did use both guns at the same time. Maybe they didn't pull both triggers at the same split second (and maybe they did); but firing two guns alternately in rapid succession is being a "two-gun man" for my money! Is a man necessarily one-legged because he walks one step at a time?

What about "fanning"? Mr. Thomas says it can't be done. Earp says, "A skillful gun-fanner could fire five shots from a .45 so rapidly that the individual reports were indistinguishable."

True, Earp goes on to say that fanning wasn't generally used for serious business. It was a trick. "Ad" Topperwein and many others can hit targets by sighting through mirrors; yet I don't suppose that Topperwein, or anyone else in his right mind, would choose to use mirrors for sighting against a shooting-back target. But is that an adequate reason for saying that such shooting is impossible—or that "fanning" is a myth?

"Fanning" is no myth. Many men now living can "fan" a gun, and throw lead with reasonable accuracy by that method. Not because he is the only man who can do it (he isn't), but because his records are applicable to more points in this discussion than are those of any other shooter—take Ed McGivern. Ed McGivern is certainly one of the (if not *the*) leading exponent of fast and fancy handgun shooting; a man who has devoted most of his life to careful experiments to determine exactly how fast and how accurately he (and other men) could fire a handgun. "Ed McGivern's Book On Fast and Fancy Revolver Shooting and Police Training" is a textbook and "Bible" for handgunners. There can be no question about the authenticity of McGivern's feats. His times are checked by highly accurate electrical timing devices and his accuracy has been proved before thousands of unimpeachable witnesses.

The two-gun man who "never existed"? Ed McGivern is a two-gun man. McGivern has demonstrated thousands of times his ability to draw and fire two guns fast and accurately. One of his "stunts" is to draw and fire two guns, five shots out of each gun, all ten shots scoring vital hits on a man-target at fifteen to twenty feet; time, two seconds. He varies this on occasion by using two targets ten feet or more apart. This is more difficult! Time for ten shots, all hits, including the two-gun draw—three seconds. Not counting the draw, McGivern fired ten shots, two guns, in one and two-fifths seconds, scor-



ing ten hits in a six-by-eleven-inch group on the chest of a man-target at eighteen feet. McGivern's exhibitions also included firing two guns on aerial targets. He scored doubles regularly, even on targets thrown at wide angles. . . . McGivern can not only do these things himself; he has taught, and is teaching others to do likewise.

"Fanning is a myth"? Ed McGivern has repeatedly fanned five shots out of a Colt Single Action revolver—the famed "Peacemaker" of frontier days—in times ranging from one second to one and one-half seconds for the five shots, all five shots grouped in a space coverable by a man's hand (often by a playing card) at ten- to fifteen-foot ranges! McGivern says that fanning is the fastest known way of firing a single-action revolver. "Fanning is not a myth; a very successful method which gives good results, properly performed and controlled. *Fanning would be practical for one man against several.*"

(Too bad Mr. Thomas's thousand-dollar check wasn't posted where Mr. McGivern could shoot for it!)

But what about "point-shooting"—shooting "from the hip"—without "aiming through the sights"? Mr. Thomas says, "It's bunk!" Wyatt Earp names "Wild Bill" Hickok as just about the deadliest man he knew with a six-gun and says, "Wild Bill held his gun as almost every man skilled in such matters preferred to hold one when in action, with a half-bent elbow that brought the gun slightly in front of his body at about or slightly above the level of the waist."

Mr. Hickok couldn't very well have "sighted" the gun, in that position, yet he killed many men. How many is a question that will probably never be answered, but you can take my word for this—he didn't miss many that he shot at! And he was a point-shooter!

McGivern can point-shoot five shots, all hits covered by a playing card at fifteen to twenty feet, in less than a second! Several of his five-shot groups, hip shooting, can be covered by a dime! (Impossible? If you think it's impossible, let McGivern point-shoot a gunful at your watch! But when you miss your trains, later, don't say I didn't warn you!)

But let's leave Mr. Thomas and his "Gun Philosophy" for the moment and look instead at that other example of expert "debunking," "Wild West Gunmen Were Not So Hot!" by that fine pistol man, holder of several championships, Charles Askins, Jr.

The principal fault in Mr. Askins' article lies in its title; for what Mr. Askins actually does is to refute, not the actual skill of actual old-timers, but the tall tales that have been told about them!

Now, I have written my share of western stories; but I would never quarrel with Mr. Askins had he written his piece under the title, "Wild West Writers Are Not So



Hot!"—for I know what crimes have been committed in the guise of "western" fiction. But what has that to do with the actual deeds of men who actually existed?

Of course Mr. Askins does, infrequently, refer to actual old-timers. For example, his reference to Wild Bill Hickok's feat of shooting at the "o" (or "o's") in a certain sign. Mr. Askins, with much rather ponderous amusement, quotes this badly shopworn tale in the words of a Mr. Alsike, who infers that the episode occurred in Abilene, Kansas, and states positively that the sign advertised a blacksmith by the name of Jim Cooley, that Hickok fired both guns simultaneously, so fast that the separate shots were indistinguishable, ending the performance split seconds later with six holes in each of the twin "o's" in the Cooley name! The distance, Mr. Askins relates, was later established as "187 long steps."

The best that can be said for that is—it is not good reporting!

Oh yes, the thing did happen. It happened in the summer of 1871. Plenty of reputable witnesses attest it. But—it didn't happen in Abilene, Kansas; it happened on the Market Square in Kansas City, Missouri. Hickok didn't fire both guns simultaneously; he emptied one, at about Timed Fire cadence, then changed guns and emptied the other. He didn't fire twelve shots; he fired ten. There weren't two "o's" in the sign; there was one. And the distance was not "187 long steps"; it was just under eighty-five yards.

It was still good shooting. But what is so incredible about it? Signs then, as now, were made to be read at a distance. Is it unreasonable to suppose that a sign made to be read across Kansas City's Market Square may have carried thirty-inch letters? Give that "o" a thirty-inch diameter, strip the story of the obvious hokum that has grown up around it, and dozens of men today (including Mr. Askins himself) could equal Hickok's feat, or better it. Why say Hickok couldn't have done it?

Mr. Askins says Hickok couldn't have done it because the guns and ammunition of that day wouldn't do it. Mr. Askins tells of two guns he tested, guns of that era, that threw groups 7.3 inches to 8.7 inches wide at fifty yards. Frank Wyman, writing for *THE AMERICAN RIFLEMAN* of September, 1936, records his own test firing of a gun of that era (an ancient Remington, Model 1858,

rescued from a pawn shop) which threw one-inch groups at twenty-five yards, using what Mr. Wyman himself described as "a misfit load."

Maybe Mr. Askins was unlucky in his choice of revolvers. But even *bis* groups, carried out to eighty-five yards, would nestle comfortably inside that "o" with a thirty-inch diameter. Even those guns would make dead men out of live ones at fifty (or even a hundred) yards. Which was the ultimate object of the men Mr. Askins is "debunking."

Mr. Askins says the tales of old-time accuracy are lies for still another reason. He says that the guns of that day which he has examined are not properly sighted and that "the old gun-fighters had never been to the Camp Perry School of Marksmanship, so they did not know anything about sighting-in a six-gun!"

Of course, under the circumstances existing, I suspect Mr. Askins of sarcasm. Nevertheless, I'm sure that the NRA and the Army are grateful for that tribute to the Camp Perry School. However, there is also a school called "the school of experience"—a school in which those old-timers made passing marks in "triggernometry" or else they died! They didn't know as much as we know today about trajectories and ballistics and high velocities and internal pressures; but they had hammers, and they had files, and they had the sense to use them! I know, for I have seen the marks of those tools on guns of that era that I have examined! They weren't so dumb, those old-timers, that they couldn't re-set a simple iron sight. They could, and they did. At least some of them did. Perhaps some of them didn't. Some of them were strictly point-shooters and, to them, the sights may not have mattered.

Mr. Askins goes to considerable pains to refute a story which he says is credited to John Wesley Hardin; a story to the effect that Hardin "used to draw his twin .41's and, fanning both guns simultaneously, ignite a dozen matches with as many bullets." (Leaving the business of match-lighting out of it entirely, it takes two hands to "fan" one gun. Hence, as Mr. Askins points out, this story is obviously impossible.)

Far be it from me to say that that story has not been told; no doubt it has. But—and this is the point I hope to drive home—that story is not a part of any claim seriously made for the record of Wes Hardin, or any other gunman. It is not even a good "tall tale." It is a stupid lie; stupid, because no one with even the faintest idea of what "fanning" is would tell it. As such, Mr. Askins does well to refute it. But refuting it does nothing at all to the tall figure of John Wesley Hardin as a gunman! Hardin's fame is sufficiently well grounded in fact to need no such lies to enlarge it.

Mr. Askins scoffs, too, at such tales as: rescuing a comrade from hanging by shooting the rope in two; shooting guns out of men's hands; shooting the spots out of playing cards tossed in the air; shooting from the saddle, at

a gallop, with two guns, hitting an endless succession of fence posts on both sides of the shooter. Mr. Askins says he built a dummy "villain" who was hanged, shot at, and otherwise maltreated in the course of lengthy experiments to prove or disprove these legends, winding up with the conclusion that since he can't do these things, therefore they can't be done.

Mr. Askins says he couldn't hit the rope in his attempt to rescue his "villain" from hanging, because it was a windy day and the rope was swinging! I ask—why didn't Mr. Askins shoot at the rope where it crossed the limb; where it was motionless?

But let's not quibble; let's suppose, for the sake of argument, that the rope wasn't visible where it crossed the limb and that Mr. Askins had to shoot at a section of the rope that was in movement. "Ad" Topperwein, "Fitz" FitzGerald, and plenty of other exhibition shooters hit aerial targets with pistol bullets; targets smaller than the diameter of any rope likely to be used for a hanging. Ed McGivern could hit dimes tossed in the air; hit them either broadside or edgewise, as requested. Hitting a rope is not impossible!

But, even if it were impossible—cutting a rope with bullets to save a man from hanging is not a part of the history, or even of the legend, of any actual gunman, to my knowledge. It is a figment of fiction.

Mr. Askins tells quite humorously how, when he tried shooting a gun out of the hand of his dummy, the gun was smashed and the dummy was punctured by flying pieces. . . . Well? Shooting guns out of men's hands is not a part of any skill ever claimed for any real gunman. Those old boys, when they drew, shot to kill!

(Just the same, guns have been shot out of men's hands, leaving the man unscathed—or nearly so. I saw one such gun after it happened. It wasn't smashed into shrapnel, either. It wasn't hit by intention, however; it was merely in the line of flight of a bullet intended for a larger and a softer target.)

As for shooting the pips out of a playing card tossed in the air—nobody in his right mind ever said seriously that anybody, either in fact or in fiction, could do it! Nobody who ever saw such a card spin and flutter and dart and dive *would* say it! It is not a part of any gunman's legend. Like the story of fanning two guns, if it is told at all, it is told by fools, for fools' consumption.

(But Ed McGivern can *split* a card tossed in the air. It's a much stiffer card, like the cardboard coasters used under glasses; and it is expertly thrown. But it's a thin target!)

Mr. Askins tried shooting off a running horse. This story of two-handed shooting at fence posts off the back of a running horse is, I believe, the only story in this sequence of tall tales that is seriously accredited to any old-time gunman. Billy the Kid is said to have done it.

Well, targets can be hit from a running horse. United States Cavalrymen do it, regularly, in firing the Mounted

Ed McGivern, dean of fast and fancy revolver shooting, shows how to "fan" a Frontier Model Colt Single Action. Impossible? Take a look at the playing-card-size group below, fired by McGivern by this method.

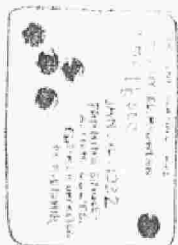

each other? I don't think so! I think Mr. Thomas would have been hit a little more than one full second before his own shot could have been fired! . . . And I think, too, that when Ed McGivern makes that half- or quarter-second draw his hand may reasonably be said to "blur with speed!" I really do!

McGivern, Groff, and others, using guns and holsters and targets carefully connected with split-second electrical timers, have recorded draw-fire-one-shot-and-hit times as low as one-fourth of a second.

McGivern has, many times, drawn and fired five shots from a double-action revolver, all hits in groups the size of a man's hand, at ranges of from twelve to eighteen feet, in times as low as one second flat.

McGivern has, at least once, fired five shots out of a double-action revolver in two-fifths of a second.

McGivern has demonstrated countless times, and has taught many others to do the often-told and frequently-called-impossible stunt of dropping a target from shoulder height, then drawing a gun and hitting that target before the target hits the ground.

McGivern, and McGivern's pupils, and scores of men not connected with McGivern, can shoot better than any cowboy I ever wrote into any of *my* stories; well enough to prove that all claims ever seriously made by any sane historian for the skill of the old western gunman are possible. Why should we doubt that men whose lives depended on their skill with guns, had it?

The handgun has a very definite place in the world of today and in the probable world of tomorrow. No other weapon has, so far, replaced it as a weapon of self-defense and of law enforcement. It has a real place, too, in sport. Let's not low-rate it.

Let's not low-rate, either, the old western gunman whose colorful legend breeds a fair share of the interest from which is born new pistolmen. We still have need of pistolmen, on the firing lines at our matches, in our armed forces, and behind the shields of law enforcement.

Debunk the old time gunman, yes; but let's stick to the truth in our debunking. And the truth is, the old timers shot right well! They did—or else!

Popular Mechanics Oct., 1902

Could the Russians have built the first tank?  
RUSSIAN MACHINE OF DEATH.

At the Russian war maneuvers at Kursk a new and remarkable death dealing machine made its appearance. The English term for the device is "land cruiser." It is a great steel clad vehicle that runs along the ground faster than any man-of-war in the water. It is capable of sweeping down whole regiments of horse and foot, and artillery could do it little harm.

Pistol Courses. True, they shoot at man-size targets which are bigger than fence posts; but Billy the Kid was probably a better gunman than the average cavalryman. . . . And suppose the story does exaggerate the Kid's skill: would Mr. Askins care to meet Billy the Kid in a shoot-out? I wouldn't! . . . And why say that Billy the Kid never existed, that his skill with guns is a myth, merely because a lot of tall tales have grown up around him?

Of course, that mention of meeting Billy the Kid in a shoot-out brings up the question of *speed*; and that is the point on which the "debunkers" pounce! We writers, seeking the apt phrase, tell how our hero, reaching for his gun, rips it from the holster so fast that his hands blur with speed! . . . And the "debunkers" chortle in the belief that they've caught us with our rhetorical pants down.

Mr. Askins went further than do most "debunkers": he tried it. He says that he and his pal, Ike Akard, practiced the draw at least a hundred times a day for a month, at the end of which time "so far as witnesses could tell, our hammers fell exactly together. We'd have killed each other dead as hell at each exchange."

But suppose Mr. Askins or his pal met a man who had practiced for *more* than a month? Or a man whose reaction-time was just naturally a bit faster than theirs?

Mr. Askins doesn't commit himself, in this article, as to his best time (in seconds or fractions of seconds) "on the draw." Mr. Thomas, in his article, did. Mr. Thomas says he found by long experimentation that "to pull a belt-gun and hit anything man-sized at ten yards and under averaged about one and two-thirds seconds."

Ed McGivern has, thousands of times, drawn and hit—not only man-sized targets but often playing cards—in one-half of one second, or *less*! The best quick-draw time mentioned in his book is one-fourth of a second.

Does Mr. Askins think that, if Mr. Thomas and Mr. McGivern had met in a shoot-out, they would have killed



# HIP-SHOOTING

By ELMER KEITH

AMERICAN RIFLEMAN September 1939

VERY fast and accurate hip-shooting with a sixgun is not the myth that many would have us believe. With enough practice the automobile driver knows exactly where each front wheel tracks, and can dodge very small rocks with ease, even though he cannot see the front wheels. The baseball player learns to swing a bat with sufficient accuracy to hit a straight-thrown ball each time, even though the ball is simply burning the breeze. The tennis player learns the same things through practice. Likewise, the typist can hit any key on the typewriter without looking, and do it instantly. The small boy soon learns to throw a rock or snowball with sufficient accuracy to hit a man every time up to ten yards. The flycaster does not aim, or see his fly until it sails toward the target or spot where he wishes to place it, yet the fly can be cast accurately enough to hit even a grasshopper floating on the water. Why, then, should so many shooters deem it impossible to hit things with a sixgun from the hip in average quick-draw time?

Almost anyone can point his forefinger at an object with reasonable accuracy, and hip-shooting with a sixgun is not nearly as difficult as many of the things above mentioned. It is simply the result of careful, conscientious practice—no more difficult to learn than any other sport, if as difficult as some. In time the sixgun merely becomes a prolongation of that pointing index finger. Men who have habitually carried and used a sixgun over a long period of time, especially in the open Western country, will automatically reach for their gun if they step on a snake, or something startles them. It is just force of habit. Many of them can also use those same guns swiftly and accurately, even though they do not take time to raise them much higher than their belt. They well know by the feel of the gun where it is pointing. They can also point it instantly at any object by the age-old poking method, the instant the gun clears the holster. This is the most accurate method of hip-shooting, and only one hand is necessary. Many who have never seen such shooting class it with the mythical dodo bird, yet there are plenty of men right in this country who can do very fast and creditable hip-shooting. Simply because a person has never himself seen a thing done is no proof that it cannot be done, or that it has not been done, perhaps many times.

As in all other forms of shooting, the more one practices, the more proficient he becomes. Hip-shooting is not nearly as difficult as standard target shooting with a sixgun. The main thing is to get the right equipment, and then practice—a little each day, if possible; and if this is continued over a couple of years, almost anyone can become proficient at the game. And it is not just a game, but one of the most valuable phases of sixgun work, once properly mastered. True, it makes a spectacular stunt for the

exhibition shot, when performed with either one or two guns, but the real value in one's ability to plant a sixgun slug where he wants it in the least possible interval of time, lies in the confidence it gives him, be he officer, soldier, or civilian. If he knows he possesses this ability, he is much more apt to act sensibly in an emergency, while if his life is at stake he will give a good account of himself.

As in many other forms of shooting, after this stunt is practiced long enough, the subconscious takes control over the muscles in an emergency. I remember once when a friend and I were walking down a cow trail in the sage brush in Montana, our bridles on our left shoulders, looking for a couple of hobbled, but strayed, cow ponies. Though it had been a hot, sultry night and the morning was already warm, the sun had not yet peeped over the low-lying hills to the East. Neither of us was paying much attention to the trail, as the tracks of our horses were as plain as a newspaper. We were watching the breaks off to our left toward the Missouri River, where we thought the nags would feed and finally keg-up for a snooze. Suddenly I felt the squirming of a big, heavy rattler under my right foot, and simultaneously heard the warning buzz of his rattles. With a yell to my partner, I jumped high in the air and to the left. I remember the jar of my .43 S. A. Colt in recoil at the second shot after my feet hit the ground, but was not conscious at the time—nor did I remember later—of drawing that gun and putting a slug through the coiled reptile while I was still in the air. However, my partner swore that I drew and hit the snake in the middle while still in the air, and the bullet holes through the snake, as well as the two small billows of gun smoke on the still morning air, proved that the subconscious part of my mind had taken care of things in that emergency.

Another time, when still a small lad, I was running a line of coyote and bob-cat traps. On a steep ridge I had built a trap pen for a cat, at the base of a big fir tree. The pen had been arranged with two walls of rocks extending out from the roots of the tree, and covered over with fir boughs. Then, with a jack rabbit for bait and a No. 3 Newhouse carefully concealed in the entrance, the set was complete. One day, on one of my trips over the line, the trap pen was conspicuous by its absence. A pile of boughs, badly chewed up, and some scattered rocks, were all that remained of my cat set. I had nailed and stapled the ring of the chain to the heavy root of the tree, and covered it with fir needles; but no chain was in evidence. The tree stood on the edge of a steep cliff to the west, while the mountain sloped away gradually to the east. Naturally thinking that the cat had broken the chain and gotten away with the trap, I knelt down and began digging in the fir needles at the base of the tree, to locate the remaining portion of the chain. Then I heard something just over





*At left: The three stages of a two-gun quick draw*

*Above: In action*

*Below: Working on the stump*



the ledge, and, kid-like, I poked my head over to see. A big tom bobcat sat there on a narrow ledge, with his head little more than a foot from my face. He jumped right in my face as I threw myself backwards. I landed flat on my back, full length, with the kicking cat on my legs and belly. Again I have no remembrance of either drawing that old .45 S. A., or shooting. But the 255-grain slug, propelled by 40 grains of black powder, struck the cat in the right side of the neck, and emerged back on the left side near the shoulder, shattering the spine of the neck. The cat was dying when he landed on me. Again the subconscious had automatically taken care of things, and I had drawn the old gun and shot from the hip even as I threw myself backwards. Had I not done so I would have had my tummy and legs scratched up some, no doubt, as the cat was caught by one hind foot, and there was some four or five feet of chain on that particular trap.

On still another occasion I had trapped a big cougar that later proved to weigh 200 pounds with nothing in his stomach but a few wilted porcupine quills and the soles of a porcupine's feet. The big tom was hooked by only two toes of the right forepaw, and had traveled down the canyon about half a mile from where the set was made, on a deer kill. He had chewed off numerous small aspens, and finally tangled the short, light toggle and extra trap around a snow brush. The toggle was a section of dry and very light aspen some 2 or 3 feet long and about 3 inches in diameter, and the two traps had their rings wired together and then to the toggle. One trap was a No. 14 Newhouse with offset jaws and teeth, and this had hooked the cougar. The other trap was a standard No. 4 Newhouse. I had covered both traps with deer hair that the old boy had licked from the deer carcass the day before, and he must have hit the No. 14 trap on his first step near the carcass, for nothing had been disturbed. The only evidence was the two holes in which the traps had been concealed, and from which they had been jerked in the first wild leap.

When I first spotted the cat he was tugging silently at the trap, and had not seen me; but when I purposely stepped on a dry limb in the snow, he looked my way, stopped trying to free himself, and sat down to await my approach, just like a house cat. I determined to get some good pictures of him, and, walking up to within eight feet, took a couple of snaps. When I would yell at him, or stamp my foot, he would lunge toward me, open his big mouth, and hiss and growl. Seeing that he was very lightly hooked, and that the toggle also was only lightly caught, I was afraid to get him riled up too much. I was very anxious to get a picture of him with his mouth open and growling at me, but each time I looked down into that cursed indirect finder, he would close his mouth and lie down in the willows. I was snapping the pictures with my right thumb while I held a cocked S. A. Colt .44 Special in the same hand. Finally I got a good exposure of the cat lying broadside and snarling at me. Then he turned away, after lunging toward me and growling, and lay down with his rump toward me, and looked off up the canyon. I knew that he could not then see me, but by the way his tail

twitched I knew also that he was up to something. Nevertheless, knowing that gun, I determined to take one step nearer and get a snapshot that would fill the picture with cat.

I never got that picture. When I raised my left foot and took that one careful step forward, the first thing I was aware of was the big cat in the air and headed my way, with his tail sticking straight up and his left fore paw spread wide and reaching for me. He came on a level with my head. Both gun and camera were held belt-high, so I flipped up the barrel of the sixgun and shot from the hip, at the same time throwing myself as far down the mountain to the left as a prodigious jump would carry me. At that, the cat went right over my right shoulder, but I noticed his teeth snap shut and his head drop down on his chest as he flashed by. He landed flat on his belly, with his left fore paw still stretched out in front of him, and the right one back along his side with traps and toggle. His tail was still sticking straight up in the air, and came down slowly behind him in the snow. He was evidently completely paralyzed except his head and neck, for though he bit at everything within reach of his head, he could not move a leg. So I did not shoot again, even though I landed down the hill with the gun cocked and on his shoulders. I had only light loads in the gun (the Keith-Lyman 250-grain solid bullet and 9 grains of duPont Shotgun), but the big flat-pointed slug had struck square in the chest and ranged upward, cutting the aorta and lodging in the spine between the shoulders. It had cut a half-circle of skin from the cat's lower jaw before hitting the chest. I dragged him out into the open, using his tail for a handle, and took another picture before he died.

That was one more time when good hip-shooting saved more than my hide, for that cat would have made short work of any man. It is one thing to tree a cougar with dogs, when he can be shot out with a .22 rifle, and quite another to trap him, have him fight a trap all night, and then tease him to get a good picture when he is already in no amiable mood. In such cases cougars will fight a buzz-saw, though ordinarily they are the greatest cowards on earth. I will never forget the sight of that big cat in the air, a few feet from my face and coming amid a flurry of snow and flying traps. A movie camera could have recorded some interesting facts about the big cats then.

All hip-shooting practice should include quick-draw work at the same time, for accurate hip-shooting is of no value without the ability to get the gun instantly in an emergency. And hip-shooting is only for an emergency at close range—say ten yards or less; then it is a very valuable asset if the shooter can draw the gun and get the shot off in a very short space of time. In all hip-shooting practice a good holster must be used to obtain any definite results. For big, heavy guns there are two types of holster: the cross-draw (with the gun butt resting just to the left of the belt buckle—for right-handed shooters—and the holster set on a slant with the gun butt tipped down toward the belt buckle); and the old cowboy holster slung on the right hip (for right-handed shooters) with the gun butt

about on a level with the top of the hip bone, the butt leaning forward. For either the cross draw or the hip draw, the gun butt, hammer, and trigger should be fully exposed. On double-action guns the trigger guard should be open at the forward end.

There are two exceptions: the Berns-Martin Speed holster, open at the front with the gun held by a spring clip; and the King Gun Sight Co. Speed holster. With the Berns-Martin holster the gun butt is rocked forward out of the spring clip, with pressure downward on the gun butt; then the muzzle is flipped upward in line with the target, and the gun fired (if the range is very close and utmost speed important), or else the gun is poked forward toward the target and fired at the same time, much as you would poke your finger at anything. With the King holster only the forefinger is used to release the gun. When the forefinger is pressed against the back of the holster through the trigger guard, it releases a catch, whereupon the whole outside portion of the holster opens at the front and flies back out of the way. The gun can then be flipped upward and fired, or poked forward and fired at the same time. The poking method is always the more accurate, though not quite so fast.

For the S. A. Colt, the best hip type of holsters are made by the George Lawrence Co. of Portland, Oregon, and by S. D. Myers of El Paso, Texas; while any number of saddle and holster makers produce good, reliable cross-draw holsters. For the Colt Single Action, nothing is as good as the hip holster, but for the double-action gun, when used double-action (as it should always be in such work), the cross draw is very fast indeed, and for some shots is faster than the hip draw; for example, when the target is to the left of the shooter (or vice versa if he be a southpaw). However, with the target in front of the shooter, the hip draw will prove the faster of the two.

I have thus far found only one shoulder holster that will permit of fast quick-draw work, and that is the upside-down Berns-Martin Speed holster for two- or three-inch-barreled guns of the Detective Special type. Intended mainly for plain-clothes men and civilians, this is a very fast draw with a concealed gun and using the right hand, while the gun can be reached readily with the left hand in an emergency. This holster holds the little gun muzzle-up, top of gun toward center of chest, the gun riding about over the left breast shirt pocket, with muzzle on a line with top of pocket.

So much for holsters. But do not attempt quick-draw and hip-shooting without such an outfit, for to do so is dangerous. For example, two friends of mine were practicing hip-shooting and quick-draw, using the front pants pocket as a holster for a .45 S. A. Colt. When one of them was drawing and cocking the gun, the front sight caught on the top edge of his pants pocket, spinning the gun butt forward out of his grasp and elevating the muzzle in line with his side, and pressure of the trigger finger fired the gun. The heavy slug penetrated cleanly through the man's right side above the hip, and out of his back, then struck his friend in the left arm, ranging back and lodging behind

the elbow. Happily, they both made nice recoveries in a short time.

And now, with the necessary equipment at hand, let us take up this hip-shooting business, and lay down the fundamental principles that must be followed in order to become expert at the game. It would take a small volume to completely cover all phases of the subject, but the following should prove useful and convey a general idea of the whole thing.

First and foremost, make no attempt at fast work to begin with. Practice with the gun filled with *empty cases*. Begin by practicing reaching for the gun and grasping it exactly the same each time. With S. A. Colt guns, practice placing the thumb on the hammer-spur and the forefinger either on the front edge of the trigger guard or just inside of the guard, as you grasp the gun. Then, if you are using a closed type of holster, slowly cock the gun as you pull it up out of the holster. Keep the thumb on that hammer-spur, even if it is full cocked, until the gun muzzle clears the leather and is flipped upward toward the target; then, and then only, drop the thumb to the side of the frame, and tighten up on the trigger as you poke the gun toward the target. Do not hurry at all during the first several days of practice—just reach for that gun and go through the procedure each time, slowly and methodically, until it becomes a habit and you automatically do it right. Then, and only then, are you ready gradually to increase your speed as you practice daily. In time you can get the draw-and-hit on a man-target at close range down to around one-fourth of a second, which is about the limit with any type of arm. With double-action guns, always use the double action, and practice grasping the gun exactly the same each time, with the finger on the trigger. Apply little pressure until the muzzle comes up and is flipped toward the target by a turn of the wrist, then operate the double action as you poke the gun at the target. For fast work in the hip draw, always tie the holster down with a leg strap or thong. With the Berns-Martin Speed holsters for the Single Action, you grasp the gun in the same way, with thumb on hammer-spur, and push the gun butt forward, pressing downward on the gun as well. As the gun is pushed forward the thumb draws the hammer back to full cock, but remains on the hammer-spur until the gun muzzle starts its upward swing.

You cannot be too careful at any time, but if you go slow during the first several months of practice, acquiring speed gradually after you have fully mastered the safety end, you will succeed.

In all so-called hip-shooting, never look at the gun. Focus your eyes upon the target—whatever it happens to be—and keep them there, paying no attention whatever to the gun, which is the business of your hand and arm, not your eyes. Stand loosely, with feet fairly far apart to avoid body sway and give you a firm stance. Under no circumstances should you ever tense the muscles of your gun-arm. The more loosely you can hold that hand and arm, the more quickly they will react to the mental impulse to draw the gun. In a gun fight, any such visible stiffening of the

muscles would only be a warning to your opponent of your intended action. Take plenty of time at first, and after you have thoroughly mastered the mechanical end of things, and are snapping with the gun always pointing on or very close to the target, practice for a time with a friend standing at one side to check the elevation of your gun barrel, and tell you if you are too high or too low. It is easy to throw a slug in line with any object, but it takes time and lots of practice to acquire the knack of getting elevations right.

The grip of the gun is also a very important item in this matter of elevations, the Colt S. A. having the best-shaped grip, as well as the best angle of grip, of all guns for hip-shooting. Next come the double-actions, either S. & W. or Colt, the former fitting my hand much the better of the two. Also, the hump at the top of the S. & W. grip suits me much the better, as it keeps the gun from rolling upward in my hand in fast double-action shooting. Stick to one gun, and practice with it until it almost becomes a part of you and you can easily and instinctively point it at any object in a minimum of time.

Practice with loaded ammunition should always be done outdoors where you are sure of having plenty of room for safety; and at first practice with just one cartridge in the gun and one shot for each draw. Never try to fire more than one shot until you are able to hit relatively small objects at from five to ten yards most of the time with one shot. Then—but only then—try two loads in the gun. Using the S. A. Colt, when the gun recoils upward, hook the thumb over the hammer-spur, and as you bring the gun down on the target again, you automatically cock the hammer. Do this each time, whether you use just two cartridges for each draw, or five.

When using double-action guns, always fire them double action; and you will soon find that this requires a firmer grip on the gun. In firing two shots after a draw, the double-action pull for the second shot is begun while the gun is pointed upward from the recoil of the first shot. Again you employ the poking method, and the heavy double-action pull helps you to bring the gun back on the target. I believe that with practice the double-action guns are the fastest of all for such shooting—when one wishes to put six shots into an object in the least possible time. For me, at least, they are much faster than the automatic, as with the latter the trigger pull is too light to assist in bringing the gun down on the target; and while perhaps you can actually shoot the automatics faster, I have yet to see them perform as accurately in very fast work. It is always best to fire just one shot at a time with the double-action guns at the beginning, then go to two shots, then to three, then to all six in two strings of three each. Finally you will become so adept that you can fire all six shots very fast, and yet closely group them at any close range.

After becoming proficient with one gun, you may wish to use two guns at the same time for exhibition purposes. In this case get good holsters; also the guns should be as nearly alike as possible. Begin at the beginning again, and use both guns with empty cases until you have trained

that left hand to duplicate the performance of the right. When this has finally been accomplished, try always to fire both guns together; that is, pull both triggers at the same time for each shot. Two heavy double-action sixguns create quite a disturbance if drawn and fired fast at some object on the ground.

I once put on a couple such exhibitions, shooting at a gallon tin can at some six yards at the start; but that can was twenty yards away, and torn to ribbons, in a very short space of time. A set of pictures (two of which are shown here) covering a similar stunt, but shooting at an old rotten stump some 18" high by 8" in diameter, at ten yards—using both guns very fast from a Berns-Martin two-gun quick-draw outfit—clearly shows the stump going to pieces under the rain of lead. For this series of pictures I used a S. & W. Outdoorsman in the left hand and a S. & W. Triple Lock Target in the right, both with heavy loads. The lighter recoil of the .38, however, constitutes a serious handicap in this stunt. The first shot from each gun registered low, but the ten other shots all went through the stump.

In all hip-shooting practice it is best to shoot first at objects on the ground in front of you, so that the bullet splashes in the dirt can be instantly noted, and a change in elevation made with the gun-hand if necessary. Shooting at small objects on the water is equally good. A gallon tin can is about as good a target as you can find to begin with. Place the can, say, five yards from you, and after you can hit it at each shot with certainty and fair speed, gradually increase the distance. I have upon a few occasions hit small objects from the hip at considerable range, but this is just a stunt, and whenever the object is more than ten yards away, one will usually have time for aimed fire—unless the object happens to be another man who is shooting at you. I much prefer large-caliber guns for this work—not less than .38, as the .22 calibers very often fail to throw up enough dirt to be instantly noted and allowances made for the next shot.

As with all types of sixgun work, the more you practice the better you will become; and the man who will conscientiously train himself along the lines suggested here would be a valuable asset to any police organization. Furthermore, he will have a much better chance of living to a ripe old age should he become a peace officer, or be called upon by our Uncle Samuel to defend our country.

### Candle Stubs Will Start Fires

Short ends of candles are useful when starting a fire with damp kindling. Light one or several candles and place at various points in the stack of kindling. In a short time it will dry sufficiently to burn. As soon as the wood ignites, remove the candles and save them for future use.

Margaret Talroe, Edmonton, Alta., Can.

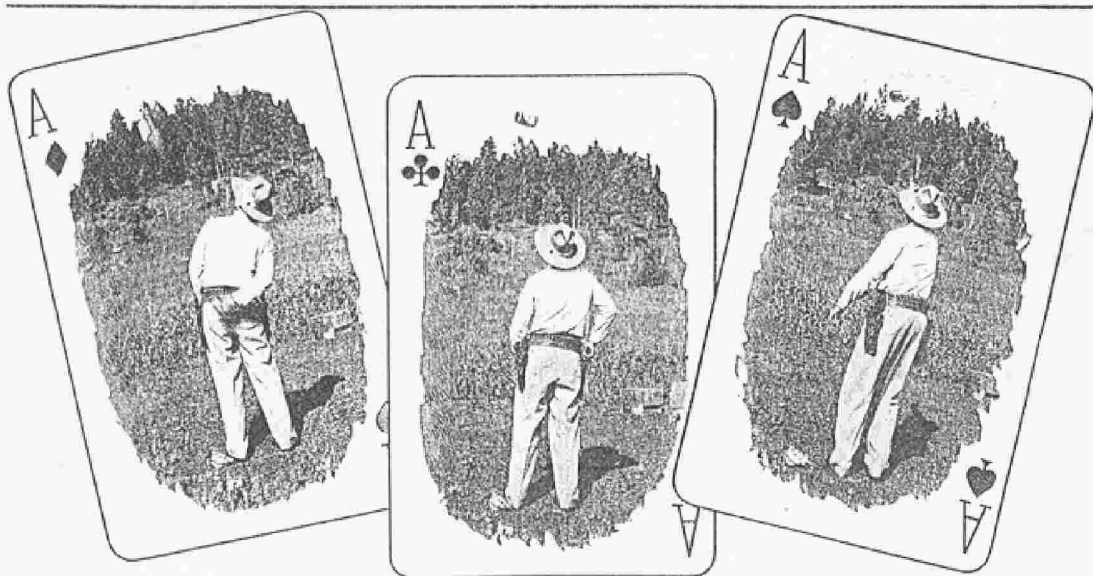

Like card tricks, fast gunplay proves the hand is quicker than the eye

THE AMERICAN RIFLEMAN FEBRUARY, NINETEEN FORTY-TWO

## "PRACTICE DOES IT!"

By CHAD WALLIN

"NO MAN IS A 'BORN GUNMAN'." "Anyone can become adept at double-action fast and fancy shooting and aerial target work if he will concentrate on the three things which mean success—patience, attention to detail and *Practice!*"

I'd heard Ed McGivern make those statements time and again. I'd read the same declarations in his book, but I never had quite believed them. Not after tossing buckshot in the air and watching them disappear before the blast of Ed's Smith & Wesson .38 and then trying unsuccessfully to get hits myself on a quart can only six feet over my head.

No sir! I was thoroughly convinced it took some subtle form of magic which either is or is not born in a man. It is because I think there are a lot of others like myself that I am writing this story. Ed McGivern showed me this summer where I was wrong.

I bewail the fact that this isn't the story of my training. Work took me away from Lewistown, Montana,

where Ed holds forth, too often to permit steady practice. But it didn't take me away so often that I was unable to observe the training of two other handgunners. It is of these and Ed that I write.

Dick Hulme, six feet of transplanted Texan now living outside Oklahoma City is one of them. Dick rolled into Lewistown with the blue birds to learn the McGivern stuff. He had no other purpose and was able to devote his full time to the task. Dr. Jack Cox, Lewistown osteopath, is the other. Doc's case is more like yours and mine. He does not have full time to devote to practice but must get out when he can. He's just a gun-smoke enthusiast.

There we have two cases—the man who can devote full time to practice and the man who must practice catch-as-catch-can. Come along into the field with me and see them and McGivern at work and learn how Ed proved his point.

When Dick Hulme arrived in Lewistown he was strictly a single-action target shooter. He shot cards running



from 85's to 98's at 25 and 50 yards—taking his time. He never had shot double-action. He was familiar with and owned a variety of handguns which he had brought along. They included everything from .22's to Magnums.

Dick had been training daily under McGivern for a week when I set out late one afternoon for the lower end of the Lewistown Rifle Club's range. I could see neither car nor men when I arrived but after cutting my car's motor I was able to pick up the "spak" of spaced shots. I headed toward the sounds and found Ed and Dick down in one of the coulees which traverse the range.

"Hiding out?"

Ed's reply bit. "Ever hear of safety?"

I then got a McGivern lecture on the first principle of shooting. It is "Be Safe!"

Concluding his lecture McGivern sat on the car's running board. "Throw a few cans for Dick," he said. "Stand about two feet to his right and slightly in front of him. Toss the can about six feet over his head. Throw with your whole arm in a smooth movement so that the can hits the same spot nearly every time."

I practiced a few throws and then Dick resumed practice. It was single-action work. He stood with the gun raised and the hammer back, and sighted for the general spot into which I pitched the can. As the can crossed that area he tried to hit it. In twelve tries he got two hits.

"I'll never do it, Mistuh Mac," he mourned. "Never; if I can't hit 'em single-action and close how can I ever shoot double-action?"

"You're doing all right," Ed replied. "Let's take a rest. Besides Wallin here is one of those writers. I want you to show him something. I have a story here by a writer saying a man shooting a .38 did the handkerchief

drop trick from his wrist and put five shots in the handkerchief before it hit the ground. Will you show him how it's done?"

Dick grinned. He extended his right arm shoulder high with his gun in his right hand at full cock. On his right wrist he placed a loosely balled handkerchief. With a twist of the wrist he dislodged the handkerchief, deflected the .38 at it and blasted.

The muzzle blast on the first shot smacked the handkerchief into the ground in a flash. "Would you like to try to put five shots in the handkerchief before it gets to the ground?" Ed asked. "Listen, if you write like the gent who said it was possible, never write anything about me."

I got the hint but I had to grin. Ed's bark is always so much worse than his bite.

"Well," Ed continued, speaking to Dick, "you've been wanting to learn to draw so let's start now. No use waiting time."

Dick was wearing an open-top, single-drop Myres holster of well-worn leather tied down with a thong to his right leg. He placed the .38 carefully in it, placed his hands center on his belt and at Ed's signal went for the gun.

"You could have taken off your pants and shaken the gun out of a pocket a little faster," was Ed's comment.

"Look here," he went on, getting up from the running board. "You're like a lot of other would-be fast draw men. You put a gun in a holster where it seems to be comfortable and then you try to get it out of there as fast as possible. You depend on muscular speed alone.

"Fast draws are as much a matter of eliminating unnecessary movements as they are a matter of making the right movements at top speed. Every individual is different and he must, by trial and error, work out gun and holster positions so that the draw is one smooth movement.

Excepting for some draws from under coats or in concealed positions, it is not a reach and pluck which means a change of muscular effort.

"Now let's move that holster down a little. Drop your hand naturally so that it reaches the butt. Now, let's slant it forward a bit."

For half an hour Dick and Ed went about the business of finding out what was the best position for that particular type of holster. Then, without a shot being fired, Ed called a halt. Satisfied, he sketched the position of the holster and he and Dick agreed that a new belt and holster were needed.

I then got an example of the McGivern teaching psychology.

"You were talking about shooting double-action," he said to Dick. "Practice a few dry shots. Let your trigger finger run out with the return of the trigger each time so that it has smooth rhythm. Just

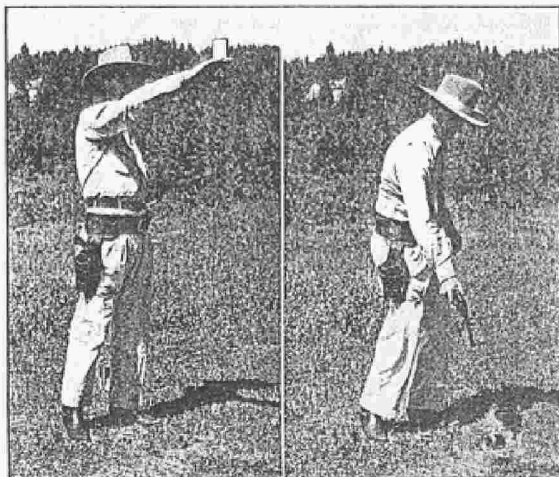

The can drop. It looks easy until you try to unhitch that six-shooter before the can hits the ground. Notice in this picture of Dick Hulme that the can is still off the ground



the tip of your finger on the trigger."

Dick complied and Ed said, "Well, there's just time for a few more single-action shots." He asked me to throw the can again.

Dick got set in his single-action pose. I tossed the target. "Crack!" It missed.

"Get it!" Ed's command almost blended with the first shot.

"Crack! Ping!" The can went whirling.

"I got it!" Dick cried. "Got it double-action!"

"I thought," said Ed, peering over his spectacles, "that you were the man who never could shoot double-action."

\* \* \*

Three weeks later I joined another McGivern shooting group. This time we were gathered on an open flat at the lower end of the rifle range. Dick was resplendent in his new two-gun belt made by Al Furstnow of Miles City, Montana. The low-hanging hand-tooled open-top holsters were beauties. Dick also had a new .22 Colt made to match his .38 Colt. Both guns were on .41 frames with six-inch barrels. Dick also had a new coat of confidence. Doc Cox produced a set of matched Smith & Wesson's. His .22 was mounted on a .38 frame while the .38 itself was standard.

Dick, who had warmed up by shooting at a stationary target, began with simple, single-action work on a quart can. Ed and Doc watched while Ed explained.

"Wait until the can gets up. Get your sights on it and stay on it. Go forward with a coordinated movement of your body. Don't try to follow it by bending your wrist. Get your shots off before the can comes down to shoulder height. While the can is above your shoulder you have two diameters at which to shoot but when it drops below your shoulder your target size steadily decreases."

Three weeks had made a definite improvement in Dick's aerial work and the new holsters had slicked some kinks out of his draw. He was eager to learn the "can-drop" trick, the real test of a handgunner's draw speed. I listened while Ed explained.

"The can is on the back of your hand, arm out at shoulder height," he stated. "First get so you can drop the can in approximately the same line every time. Then forget about the can."

"Start to shoot the moment you start your arm down. It will take a lot of practice but your shot really starts the moment your hand goes for the gun. Your trigger finger must be curved and ready to meet the trigger as it clears the holster. The squeeze goes right on through."

"Get your shot off so the bullet at first traverses an area the size of the can about six inches off the ground. You don't think about the can because when your draw is fast enough the can and bullet will meet. The shot is double-action."

Remember, fellow beginners, Dick had had a month of

training. He had shown improvement. He was no stranger to guns. He had been hitting aerial targets double-action. Yet now, as he entered another stage of training, the pressure was on. He fumbled the gun. He caught the sights on the holster. He could not even get his gun out, much less a shot off before the can hit the ground. This isn't related to belittle Dick Hulme. It is stated as fact to show that every time you attempt a speed stunt you don't need to get discouraged. Dick didn't. He kept right at it.

There was a pause for lunch and then practice resumed. Dick alternated between fast draws and aerial work on three-inch rosin balls. Double-action, Dick was getting four out of five. But you don't stop at four out of five with McGivern. With big targets like three-inch rosin balls it is five out of five.

Doc was beginning to get hits and Ed worked with him correcting his position, his grasp on the gun, his sighting. It was late when once again the McGivern psychology

The first stage of aerial training. Doc goes after a can tossed by Dick Hulme. Note the forward sway of Doc's body and rigid arm as he "leans" on the shot



moved in to give Doc a boost. Doc was more than a little skeptical of his future in the aerial game. "Get your .38," Ed ordered. To Dick he said, "Get a rosin ball and make the toss."

Doc, who had been missing quart cans, eyed the three-

inch target. "Sure you can hit it," Ed told him.

Doc lined out his gun. "Relax. Never tighten up," Ed advised him. Doc's muscles let go a little. Dick made the toss.

"Wham!" Doc got a dead center hit.

"Easy, isn't it?" Ed asked.

Doc smiled agreement. There is nothing quite as satisfying as the way a rosin ball flies apart when hit.

\* \* \*

Dick Hulme started to learn in May. Doc Cox started in June. Throughout the summer I now and then joined the shooters and, possibly because I was away and then returned, could notice improvements in their gun work. It was not until late September, however, that I came in for the finale, the proof that every man can learn. Walter Groff, McGivern's understudy and a finished handgunner, came out from Philadelphia enroute to his ranch near Winifred, Montana. Ed made a party of his visit. We went to an ideal pistol range on the McEweney ranch in the Judiths. There a small flat for aerial work ran up into a gulch where there were secure natural barriers for other shooting.

I'm not going to write much about how that day proved that practice does it. I'm going to let the pictures tell that story.

After a warm-up on stationary targets the real shooting of the day began. (A tip—don't ever try any fancy stuff cold. Consider that every athlete warms up before he enters an event and that real shooting demands the tops in muscular coordination.) Walt opened by placing six large blue rocks against a plank, making six fast draws and breaking all targets. He used a Smith & Wesson .38 and wore a Myers Buscadero belt made to his personal specifications.

Aerial work started with quart cans, worked down to Blue Rocks, then Mo-Skeet-Os and then to shooting at the brass cases of shotgun shells from which the paper had been cut away. Targets were tossed directly overhead, over the gunner's head from behind, thrown in toward him and across in front of him. Since Walt had not had much practice for two years Dick and Doc were right after him. The competition was keen and Dick and Doc, who early in the summer had not been able to hit one of a dozen, were smacking the smallest targets right along with Walt.

#### THE AMERICAN RIFLEMAN

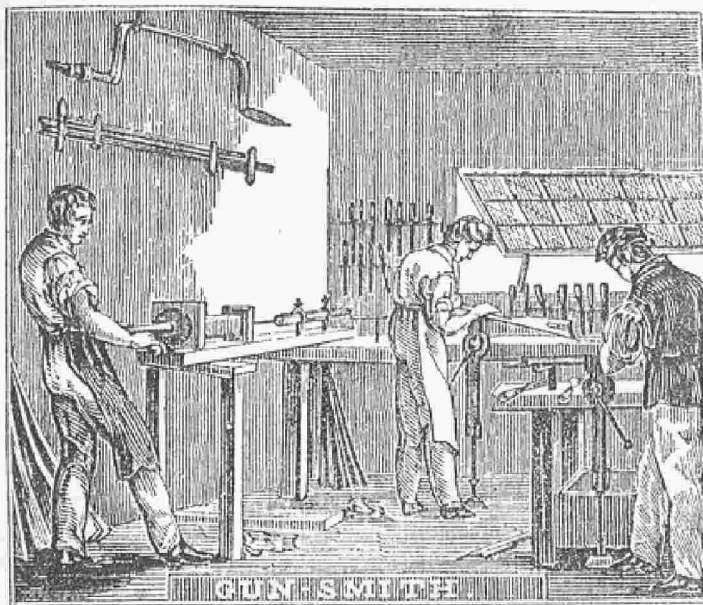

THE PICTURE FROM WHICH THE INTERESTING CUT AT THE LEFT WAS MADE WAS SENT TO US BY MR. FRANK A. TAYLOR, CURATOR OF THE ENGINEERING DIVISION OF THE U. S. NATIONAL MUSEUM, SMITHSONIAN INSTITUTION. THE PICTURE WAS MADE FROM AN OLD WOOD CUT APPEARING IN THE BOOK, "PANORAMA OF THE PROFESSIONS AND TRADES," BY EDWARD HAZEN, PUBLISHED IN PHILADELPHIA IN 1877. THE BOOK WAS LOANED TO THE MUSEUM BY MR. J. E. COLEMAN, A CLOCK MAKER OF NASHVILLE, TENN., WHOSE HOBBY IS THE OLD-TIME CLOCKS WITH WOODEN MECHANISMS

**THE DAY MARS INVADED****WASHINGTON****By Kurt Saxon**

Clarence hated Martians. He had hated them since he'd watched a science fiction story on Martian invaders a few weeks before on the ward's TV. This hatred and then fear was reinforced by a re-run of the old Kevin McCarthy version of "Invasion of the Body Snatchers". He was the only person in the State Hospital who realized the Martians were getting in just like plant pods, growing bodies occupied by the souls of Martians.

To Clarence, movies were true and on purpose. They were made and shown to alert him to the dangers to those he loved, which was everybody. He retained them and called up incidents from them in flashbacks whenever he was uncertain. His guides saw to that.

So Clarence knew all about the Martians. But his doctor would not believe him. Not even when he told him, in great detail, the explanations given to him by the voices who counseled him and warned him of the danger to the country from the Martians. The attendants wouldn't listen and some even laughed.

Then his doctor had a stroke and had to go on indefinite leave. About that time, orders came to release the non-violents to make room for more patients. Overcrowding and understaffing made Clarence a good candidate for release. He was a gentle, caring person and his voices had never encouraged any troublesome conduct.

Had his doctor been there he would have warned the board. But he wasn't there and his scrawls were hard to read. Anyway, all those psychiatric terms were Greek to the social workers on the board. This amiable schizophrenic would be no problem, even if he did hate Martians.

One of the social workers read from Clarence's chart, as best she could, "...pathological hatred of Martians... spirit guides may direct him to.. potential..." She put the chart down, saying, "I can't read this."

Jackson, senior board member said, "A lot of malarky, if you ask me. I don't care if he hates Martians. He's got no record of bothering people. I vote we process him out of here."

Clarence's landlady in a rundown apartment house in downtown Washington was a sweet old redneck. As she opened the door to the little kitchenette she told him she was glad to rent to "one of us," tossing a glance over her shoulder at a black tenant. Clarence didn't follow her glance. It wouldn't have mattered, since Martians came in all colors to the unknowing. But he saw them as they were, gray, with

great dark eyes, as the flying saucer contactees described them.

She added, "I don't mind saying I'm afraid of 'em. They're taking over. It seems like only yesterday when just our kind were here."

"Only yesterday," Clarence repeated. "Don't worry, though. Help is on the way."

Just then there was a commotion as a little girl pushed a small boy down the stairs. The landlady handed Clarence the keys and bustled off to see if the child was hurt.

"So she can see them too," Clarence said aloud to his guides. "But she's too busy with unimportant things to be of use."

He then went inside and looked around. "It seems all right," he said to them. "You heard her say it was only yesterday. We'll have to get to work."

As he unpacked his suitcase he answered one of his guides, "Yes, I can do it if you point out the targets. I don't want any Earth people to get hurt, unless they're pro-Martian. But now I have to go out and buy the stuff we talked about. Of course I know what to buy. I had chemistry all through high school. You know that."

As he opened the door to leave, he said, "I'll talk to you when I get back. I have to concentrate now."

His strategy was to make and use ammonium nitrogen tri-iodide. This is a substance which, when dry, will explode at any vibration—the touch of a feather, a breath, a rise in temperature. The undefusible bomb!

He walked to the nearest drugstore and asked the pharmacist for a bottle of iodine crystals but he had none. He went from one drugstore to the next until he neared a large hospital. That pharmacy stocked it for hospital use. The pharmacist asked Clarence what he wanted it for.

Clarence was a smooth talker and had a cover story ready. "I rented this old house and it's a mess. The landlord gave me cheap rent to clean it up. But it smells like eight people died there. What you do is put a teaspoonful of iodine crystals in bowls in every room and it dissolves in the air and fumigates the place. Kills all the germs, too."

"My grandma did it that way. Of course, you shouldn't be in the room for twenty-four hours while it's working."

The pharmacist commented that he'd heard of that and sold Clarence a four-ounce bottle.

Next, Clarence went to a supermarket and a hardware store and bought lots of odds and ends. There was cleaning ammonia, four cartons of book matches, four four-foot lengths of one-half inch PVC tubing, a package of thirty #7 Water Gremlin split-shot fishing sinkers, coarse sand paper, rubber tape, two half-inch dowels, Super Glu-Gel, a hacksaw

blade, etc.

When he got back to the little apartment, Clarence set about making a simple still from quarter-inch plastic tubing, a light bulb, two tin cans. Goop, a No. 6 cork, a Tums bottle and a two-quart plastic container. When he got it set up he quickly distilled two ounces of very strong ammonia from the weak and soapy mess sold as a cleaner. While he worked he gleefully explained aloud to his guides every step and the impact of the project on the Martian invaders.

Then he cut off all the match heads from the four cartons. He put them in a shallow bowl and poured boiling water over them. Next he stirred them until the potassium chlorate and sulphur making up the heads dropped away from the cardboard. He then scooped out the cardboard and put the bowl in the oven at its lowest heat to evaporate the liquid.

Then he proceeded to cut the PVC tubing into 128 one and a half inch lengths. Next he sanded the edges of both ends of the dowel before cutting off one-quarter inch at each end. This was so they would go into the tubes easier. He repeated the process until he had over 200 tube stoppers.

Clarence was fortunate that his landlady was health conscious and had chronic indigestion and that she saved everything. He had seen rows of plastic bottles of Tums, Roloids, and vitamins in her office. When he asked if she had any empties she was happy to give him a sackful. He took them to his apartment and chose thirty which would hold just over six ounces.

His next step was a visit to two different gas stations with a gas can. He had decided on thirty gas bombs and was vexed that he had to make two trips. He was short fifty-four ounces and so had to make that extra trip, and to another station so as not to be noticed. Weren't twenty-one gas bombs enough? But orders were orders.

When he got back he put six ounces into each of the thirty bottles. Then he upended them to test if the lids could be screwed on tight enough to prevent leakage. They didn't leak.

His next job was to put Super-Glu-Gel around the inside of the PVC tubes and press in the stoppers.

By the next day the water was evaporated from the match head mixture and he scraped it off the bowl and powdered it with the bottom of a spoon. He put the thirty sinkers in tubes and filled them two-thirds full with the powder and set them aside. When these were done he put the same amount of powder in the other seventy.

Then he crushed a half ounce of iodine crystals to a powder, poured it into a pill bottle and poured in an ounce of the strong ammonia. After snapping the lid on tight he let it set for a half hour. He then poured the liquid and mush into two piles onto a newspaper and

let most of the liquid be absorbed. He scraped one pile up while it was still quite moist and left the other pile alone until it showed little moisture.

"You see," he said to his guides, "I have to put in just enough crystal to ignite the powder. If I put in too much and it breaks the tube so the gasoline floods the powder, the powder won't explode and vaporize the gasoline. Also since there will be more vibration on the bus the moisture in the crystals will dissipate and dry quicker. So the moister crystals will go in those twenty for the buses. Since there will be no vibrations in the mail boxes except for maybe bunches of letters hitting, the dryer stuff will go in those ten gas bombs. The seventy for the car gas tanks will be dryer since they'll just be lying in there until the cars are well on the road.

"Of course mail boxes. We agreed we should disrupt communications. I don't care; don't argue with me. I'm not going to argue about it.

"The sinkers? Oh, they're to make the gas bombs explode up instead of down, like it would if the tube was floating."

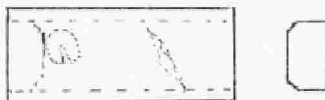

Clarence had to test the product, so he used a razor knife to pick up a bit of the dryer crystal and set it aside while he filled a spare tube three-quarters full with powder. Then he dropped in the crystal and sealed the tube with a dowel piece smeared with Super-Glu-Gel. Next he put it in a small cardboard box, wrapped the box in a blanket and put it in the oven.

Before his guides had taken him over in his last year of high school, Clarence had been an A student in chemistry. He loved novel chemical reactions and was quite a practical joker then. He had played with iodine bombs and other stunts so often he knew within a half hour just how long it would take for one to dry and then explode.

After a little over an hour he opened the oven door slightly and jiggled the bundle with a stick. There was a muffled bang and a couple of PVC particles came through the box and blanket and hit the sides of the oven.

After the testing Clarence proceeded to load the tubes for the car gas tanks. He put in three-quarters powder and measured out a piece of the least moist paste about the size of a quarter grain of rice. When it was in he put Super-Glu-Gel around the bottom of the stopper and pressed it flush with the tube. After doing ten he put them into the freezer compartment of the refrigerator to keep them from drying. When the seventy were done he began the gas bombs.

Clarence then started on the thirty gas bombs. He dropped a sinker in each and put in the two-thirds powder. He set ten aside and dropped in a bit of the moister crystal in the twenty and put in the dowels. Then he put them in the freezer compartment and started in on the ten for the mail boxes.

Since these would not be jostled much and needed to dry faster he used the dryer crystal. He also put the ten in the freezer. He put all the gasoline bottles in the refrigerator to cool, giving him a few minutes more before the tubes would warm up enough for the crystal to dry.

About 2:30 p.m. Clarence uncapped the gas filled bottles and dropped twenty tubes in and marked them. After closing them tightly and putting them in his airline bag he did the same for the ten for the mail boxes. Then he left for the bus stop a block away.

His first targets were bus-loads of Martians. The buses he chose were those serving Washington proper, avoiding those headed for the suburbs. Of course, his guides would direct him. Even so, most of the local buses were filled with Martians.

Some of the passengers were children. But Clarence remembered a movie wherein General Phillip Sheridan said of killing Indian youngsters, "Nits make lice."

Just before the first bus reached him he had a thought. Or maybe one of his guides gave it to him. At any rate, if it worked, the guide would take credit for it. The thought was that maybe someone would see what he thought was a lost bottle of Tums and take it. It needed a disguise. There was a trash receptacle nearby so Clarence reached in and got three dirty fast-food sacks. He put two in his pocket and stuffed a gas bottle in the last. No one would care to pick that up.

Just then the bus stopped and he got on. He then followed the procedure he had rehearsed in his mind with his guides. After putting the coins in the box he pretended to drop one. He backed up slightly, facing the front and bent down. Then he put the bottle of gasoline in its paper sack under the driver's seat.

He then straightened up and made his way back to the side exit. After two blocks he pulled the cord and got out. Looking around, he spotted a public mail box. He opened his airline bag and popped one of the ten into the hopper and then crossed the street as another bus going back stopped. He got on and repeated the process. In a little over half an hour he had gotten on and off twenty buses and planted the other nine gas bombs in mail boxes.

As his last bus passed near his apartment house he got off. He went in and emptied four ice trays into an Igloo Little Playmate drink cooler. Then he put the seventy gas tank bomblets in a large zip-lock baggie and pushed it down into the ice.

Off he went again and took a bus to a large parking lot he had passed before. He removed several bomblets and put them in his pocket. As he passed among the cars he opened the gas flaps and checked to see if they had locking gas caps.

Few did. Since most gas tanks had baffles to prevent siphoning, they were unneeded. Besides, Martians didn't use locking gas caps. One after another he poked a bomblet into the gas tanks of seventy cars. It was now nearly four p.m. By shortly after five the crystals would be dried and, as the tubes were jostled by the cars' motion, they would carry the Martian drivers to a fiery doom.

Instead of getting back on a bus that might have a bomb on board he walked the ten blocks from the parking lot to the apartment house. He stopped at an appliance store and bought a cheap black and white TV.

At 5:22 p.m. the first bomb went off on Pennsylvania Avenue. The bus was packed, as usual for that time of day. Fifty cubic feet of flame engulfed the Martian driver and passengers crowded at the front of the bus. The driver could not have opened the door even had he had the presence of mind for the press of burning bodies blocking the entrance.

The bus lurched drunkenly out of its lane, smashing into several oncoming cars and blocking the street in both directions.

Inside the bus, flaming clothing spread a pall of choking smoke toward the rear. Those standing at the side exit pulled the cord in vain. Whatever emergency exits there were were not used in the panic. As the flames spread, the smoke killed every Martian on the bus.

An Earth person on the sidewalk with a Camcorder caught the scene just as a Martian in a postman's uniform opened up a mail box. As smoke seeped out the cracks in the bus, the postman automatically reached down for an armload of mail. The Camcorder caught him just as one of the bombs exploded in his face.

As this scene was shown on TV an hour later, Clarence was reminded of the old Blondie and Dagwood movies showing the everlate Dagwood running into the mailman and scattering his letters to the four winds. Only the letters on TV were on fire.

At 5:30 the large parking lot was nearly empty, with most of the Martian targets well along on the streets and freeways. But three cars of late leavers went up almost simultaneously. One exploded spontaneously. Another erupted just as the driver opened its door. The last blew up just as the driver and its passengers neared the exit.

On the freeway a car burst into flames and careened until stopped by several others. This caused



a classic jam, piling up several hurrying vehicles and stopping hundreds of cars behind. Two stopped cars then flamed almost in unison, endangering the surrounding autos and causing their passengers to get out and clamber over those nearby.

Within minutes of the initial explosions the TV and radio blasted forth panicked warnings. "Washington is under attack! Buses and cars are being bombed all over the metropolitan area and even on the freeways. Do not board buses. Stop your cars and get out, NOW!

"Reports are coming in that even public mail boxes are exploding. At least one postman collecting from a mail drop on Pennsylvania Avenue has been incinerated."

Every station had similar reports. As the minutes wore on, these reports became more hysterical. They reminded Clarence of the anguish of the reporter covering the Hindenberg tragedy.

Within an hour, anchormen told of hundreds, maybe thousands of lives lost, fifteen or more horrific traffic jams, the inability of fire engines, police or ambulances to get to the scenes of destruction.

Government spokesmen editorialized on massive terrorist attacks on the nation's heart. "It's obvious that these outrages have been orchestrated by Saddam or Quadafi or both in concert. The carnage is terrible. It's estimated by top government intelligence agents we've been able to reach that this assault on our capitol has been perpetrated by dozens of highly trained terrorists armed with the most sophisticated destructive devices."

Three Egyptian tourists running from a burning car were shot down by an off-duty Secret Service man. Middle-Easterners were being arrested on sight. Clarence remembered the documentaries showing Japanese-Americans being rounded up after the bombing of Pearl Harbor.

A commercial for Jiffy-Pops was interrupted by a screaming anchorman, along with an on-the-spot live film, "Hold on. Wait a minute, oh, NO! Eight troop-filled helicopters sent to guard the president tried to land on the White House lawn. Two have run into each other and as you can see, one has landed in the street crushing several cars and, good God! the other is in flames and wobbling through the roof of the White House!

Throughout the evening the reports continued. The body count was up to two thousand and rising. Martial Law was imposed and being enforced with as much lack of judgement as possible under the circumstances. All armed forces were on full alert and jets in the Middle East were being readied with smart-bombs.

The mayor of New York came on TV and pleaded for restraint, as already, his Middle-Eastern commu-

nities were being mobbed by vengeful rioters. "The outbreaks of violence against Moslems must be stopped," he warned.

He had said "Moslems." Clarence heard "Martians." His next SSI check would be here in three weeks. He had always wanted to visit the Big Apple.

## CLARENCE'S STILL

The still Clarence made is about as simple and basic as a still can be. Yet it is functional, professional and sturdy. It takes only a few minutes of actual work to make and isn't at all complicated.

This still is only to remove substances lighter than water, such as ammonia and alcohol. Although it takes only a few minutes to remove ammonia, alcohol, etc. from the water, to take the water from a heavier substance would take too long to bother. For such a job you'd want a still to which the heat was applied directly.

To use this still your only real expense is the hotplate. These cost about \$15.00 from Wal-Mart or maybe you can pick one up for much less from a thrift store. If you're going to be playing with chemicals, you'll need one anyway. An accident over a hotplate is much less messy than on the kitchen stove.

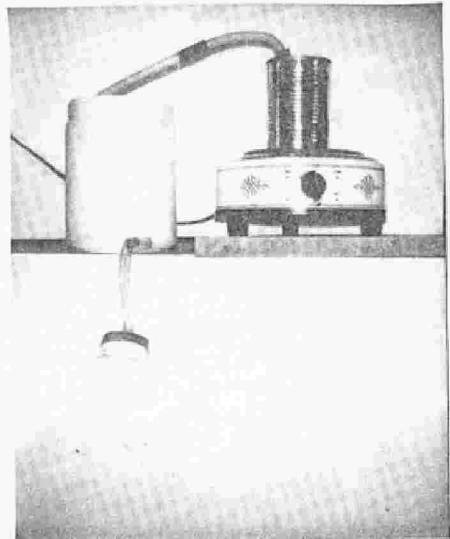

Another expense, if you don't already have one, is a small power drill. They cost under \$20.00 at Wal-Mart, even with a set of drill bits. You need one anyway.

Small items you need for the still are: 5 feet of 3/8 inch outside diameter plastic tubing, a few No. 6 corks, a tube of plumber's "Goop" plastic glue and a roll of duct tape. These are all bought cheaply from any good hardware store.



To weight my condenser I used a 2 inch long connector for 1 inch pipes, threaded all the way through. Those specifications aren't really important. It's the weight and the width. You need the weight to keep the tubing down so the flow is even. You also need the width to keep the tubing from flattening out, as it will if you wind it around a more narrow pipe.

So get a short length of metal pipe 1 1/2 inches or more wide and two or three inches long. Wind the tubing around it four to six turns and secure it with an 8 inch strip of duct tape split in half. Hold the wound tubing securely, press the tape along one side and lap it over the inside on both ends. Repeat on the other side and the coil will be secure and will last for any number of distillations.



Next get a plastic container of no particular kind except it should hold about a quart. Punch a 3/8 inch hole at its bottom and push the lower tube through, pulling it so the condenser is flush with the hole. Then squeeze a generous amount of Goop around the outside so it will seal it watertight. Put the unit in a well-ventilated place to stiffen overnight.

The condenser should be perfectly level in the bottom of the container. If it tilts, put a 1/4 inch slab of wood under it to make it level.

Now get a few burned out lightbulbs and, with a needle-nose pliers, pick out the brass terminal. Then pick out the glass or tar until you expose the filament base. You can now give that a sharp tap with the needle-nose so it falls inside the bulb. The technique is shown in the tape. "The PMJB Greets the Russians."

When the bulb is empty, ream out any sharp edges with the needle-nosed pliers.

Now for the stopper — extremely important so must be carefully made. Take a No. 6 cork and drill a hole through its length, from the bottom, with your smallest drill bit. Go from the smallest, then the next

size and on to the 3/8 size drill bit. This is necessary, as the cork is fragile and will probably come apart if you try to drill the hole with the largest bit first.

That's why I suggest you get several drill bits, just in case.

When the cork is properly and uniformly drilled to accommodate the tubing, squeeze some goop around the end of a 6 inch length of tubing and push it into the top of the cork. When it's through, make sure no Goop clogs the opening. Let the Goop set overnight to stiffen.

The collecting bottle can be of any sort, just so it's tight.

It should be of clear plastic or at least so you can see if there's liquid inside it. I suggest a Tums or Roloids bottle.

Just punch a 3/8 inch hole through the metal cap and cardboard liner and put a 6 inch length of 3/8 plastic tubing about a quarter inch through. Then Goop it on both sides and let it set overnight.

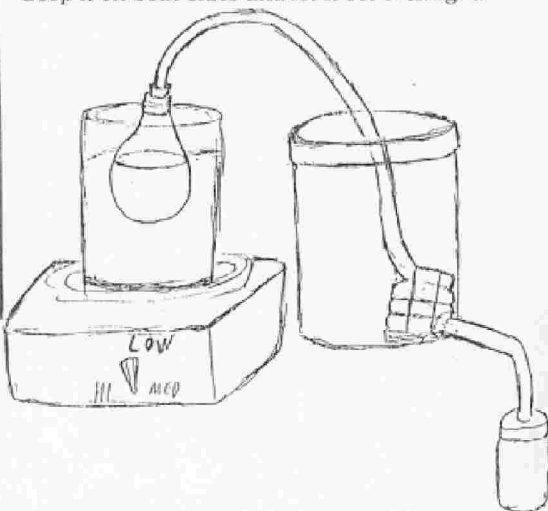

When all the components are made, it's time to splice them together. Don't bother to get all the tubing measured, wound, taped, pushed through, Gooped and all that without splicing. It's more trouble than it's worth. Just do as I suggest and splice the parts together when the unit is ready.

First splice the collecting bottle cap tubing to that coming out of the condenser. Cut a couple of inches of duct tape and cut that down the middle. Set up your hotplate, put the tin can on, put the cork in the bulb and put the bulb in the can. Set the condenser close to the hotplate and then see how much tubing it takes to reach from the cork tube to the condenser tube. You don't want it any longer than it needs to be.

Now cut the connecting piece and splice its ends

to the cork tube and the condenser tube. Splicing is simple. Just hold both ends together and press them to an end of the duct tape. The splice will seal completely and last indefinitely.

Then splice the collecting bottle cap tube to the condense tube in the same way. The collecting bottle doesn't need to rest on anything. Just let it hang.

Now for the distilling. Fill the condenser with ice and add water to its top. Put about 4 ounces of cleaning ammonia in the bulb and put the cork in securely. Fill the tin can half full with water and put the bulb in. Bring the water to a rolling boil and watch. In a few minutes the ammonia will begin to distill and beads of liquid will begin to form above the cork and begin to roll down into the condenser.

If the ammonia bubbles furiously and bubbles start up the tube, don't panic. Just turn down the heat. A little soap won't ruin the batch. It's the strength of the ammonia that matters. But if you keep the water at a rolling boil, the bubbling shouldn't get too violent.

In a few minutes you should have about an ounce of liquid in the collecting bottle and the action will seem to stop, even though the water in the bulb is still

rolling. This means most of the ammonia is out. Since 1 part of iodine crystals is treated by 1 1/2 half parts of strong ammonia, you have more than enough to have a lot of fun with.

If you should smell ammonia during the process, tighten the cork and the cap. If you still smell it, use more Goop.

Once you've made your still and actually distilled something you'll feel proud and accomplished.

## POPULAR MECHANICS

April 19, 1902.

### AN ALMANAC OF CRIME.

A volume published by a foreign criminologist is called the "almanac of crime." Its object is to indicate those periods in each year when various crimes are most likely to be committed. Here are some extracts:

**Murder.**—Many cases of this crime occur in August, January and June; few in November, February and December.

**Infanticide.**—Dangerous periods are February and May; very few cases occur in September and December.

**Poisoning.**—May is the favorite month for criminals of this type. During September, as a rule, they remain absolutely idle.

**Forgery.**—During April, October and December forgers are most busy and also during the last days of every year.

**Theft.**—More crimes are committed in December and January than during any other months of the year.

Popular Science Dec. 1955



### Clothespin Shoots Arrows into a Tin-Can Target

A YOUNGSTER can while away many winter or rainy-day hours with this clothespin slingshot. Tape a rubber band around the clothespin just below the crotch. Whittle arrows from splinters of wood, gluing a piece of dowel to the leading end of each as a weight to keep it straight in flight. The target is a can on a stick. A wadded cloth in the bottom of the can will keep the arrows from bouncing out.—*Sam Grant, New York City.*

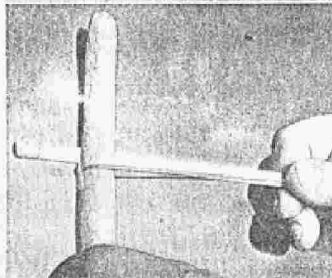

## CLARENCE AND THE GAY MARTIANS

BY KURT SAXON

Clarence struggled up the three flights of stairs to the little room in the New York slum, carrying two suitcases and his airline bag. There were no cooking facilities and no refrigerator. No matter. He had his hotplate and there was a Mom and Pop four doors down the street.

After destroying the Martians in Washington, D.C., he was eager to rid New York of them. But where to start? His little TV might give him some leads. He unpacked it and plugged it in. Several hours of newscasts, soap operas and cartoons told him nothing.

His window was open to the spring air and a scroungy tomcat came in from the fire escape and looked around. A good host, Clarence rummaged for something to feed it. It turned up its nose at his offering of Fritos and day-old pizza.

Without a second thought, Clarence hurried down to the Mom and Pop and bought a half-gallon of milk and some Sheba. When he got back the cat was leaving but decided to stay when the can was opened.

After feeding the cat, Clarence settled back to watch a movie. It was "From Here To Eternity", starring Montgomery Clift. As the story went, Clift was a soldier stationed in Hawaii before the attack on Pearl Harbor. During the attack he was off the base and in civilian clothes. That evening he tried to get back to the base and a nervous guard, not recognizing him as a soldier, shot him.

Clarence was impressed by the movie because he remembered watching a talk show where he learned Clift was a homosexual. He saw a pattern in all this and discussed it far into the night with his guides.

It was pointed out to him that the movie was a message. Of course, the movie was true. His guides helped him piece the plot together. They weren't very bright, as guides go, and Clarence knew it. But with his help, they figured it all out.

Homosexuals were banned from the armed forces. Clift had infiltrated. But why would a homosexual want to be in the armed forces? Simple. He must be a Martian. If Martians could infiltrate the armed forces of the United States they could take over the world. When Clift was in civilian clothes the guard recognized him as a Martian and shot him. The guard knew what the Martians were up to.

Now the news was full of homosexuals wanting to get into the military. Since Bill Clinton wanted them

in he must be the Arch Martian. Later for him. But right now, Martian homosexuals were the next target.

Clarence had known a homosexual in the State Hospital. He wasn't a Martian. So not all homosexuals were Martians. He couldn't go knocking off just any homosexual. He'd have to find where the Martian homosexuals gathered to plot and conspire and recruit those who would join the armed forces.

Next morning Clarence walked down the street until he came to a newsstand. There he saw dozens of guides to the Big Apple and its many attractions. He reasoned that out-of-town Martian homosexuals, not being smarter than Humans, would need directories, the same as tourists.

He approached the stand's owner and asked, "Do you have a directory telling where homosexuals get together?"

"We got a bunch of 'em, Mac", said the owner. Do you like leather, young ones, your age, or what?"

It became obvious to Clarence that the stand owner believed him to be a homosexual. So he wasn't one or a Martian. He was just selling. Clarence had no idea what the reference to leather meant. But he didn't want to take a chance on limiting his choices.

"No Sir", he said. "I just want a general directory".

"Sure, Mac", said the stand owner. "Here's one of the most popular, 'Boy's Night Out'. This is the candy store of fag rags. No offense".

Clarence handed over the price and took the magazine home. He had a New York City map and made check marks on all the addresses. Then he discussed the potential targets with his guides.

Then he had to figure how to destroy the gathering places, bars, where most of the Martian homosexuals would meet. The plan was also to destroy as many Martians as possible.

While thinking, his eye wandered to the plastic milk carton. It was nearly empty, as the cat drank a lot and Clarence helped. With no refrigeration, it wouldn't keep so he'd have to get another carton that afternoon.

That plastic milk carton would hold a half-gallon of gasoline. With a self-detonating bomb inside, any bar would be instantly filled with glorious fire. No Martian could escape it and within seconds there would be no life left.

He went downstairs and around the back to the

dumpster. He rummaged around and found five empty half-gallon milk cartons. He then went to the Mom and Pop and bought two cartons of chocolate, one buttermilk and then one regular for the cat.

Then he took a bus to the nearest hardware store and bought a six foot length of half-inch PVC tubing, a turkey baster, a gallon of white enamel, a two-gallon gasoline can, a half-dozen cartons of book matches and tried to buy a package of clear-plastic drinking straws. But the only ones sold to the public were the stripey kind which were hard to see through.

He had lunched at a diner earlier where cheaper clear straws were free with the drink. He went back there and bought another soft drink and took about a dozen of the clear straws.

When he got back to his room he put his purchases down and left with a bottle and the turkey baster. He looked for an abandoned car. This was a junky neighborhood so most of the cars parked along the littered curbs could have been abandoned. He tried door after door until one opened and he reached under the dash and unlatched the hood.

He raised the hood and removed the caps from the battery. Then he stuck the turkey baster in and drew up some battery acid. He squirted it into the small bottle and after two draws he had six ounces. A few people passed by but paid him no attention. Just someone working on a car. Before he left, he put a short note under the windshield wiper, "Your battery needs acid". Clarence was very conscientious.

It was nearly dark when he got back to his room. He poured some milk for the cat and gave him some more Sheba. Then he attached an extension cord to the hotplate and put it out on the fire escape. He plugged it in and poured the battery acid in his little enamelled saucepan. Next he turned the hotplate on to medium and settled down to watch TV.

After an hour he checked it and a good deal of the water had boiled away. He went back to the TV and soon he smelled the fumes of sulfuric acid drifting in from the outside. He checked again and white fumes were coming up so he knew the acid was ready. He unplugged the hotplate and shut the window so no more fumes would come into the room while he waited for the hotplate to cool and the fumes to stop coming off the acid.

Later, he took in the saucepan and poured the one ounce of sulfuric acid into a plastic bottle. Then he cut 40 1 1/2 inch sections from the plastic straws. Next he took the tube of GOOP left over from Washington and pushed each section 3/16 of an inch into the glob, wiped them smooth and set them aside to harden. He left them alone all night and proceeded the next morning.

Now he needed a stand for them so he could prop

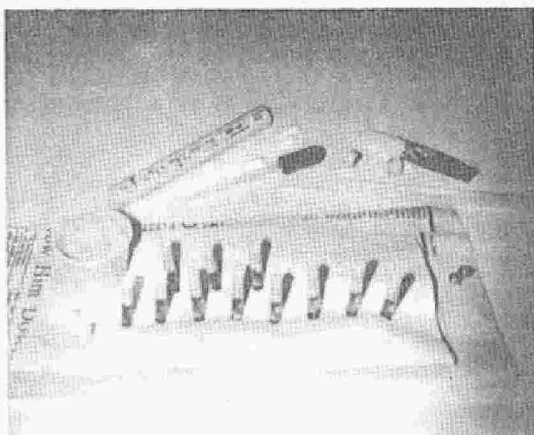

Match head flakes PVC Tubing Q-Tips  
Clear Straws Plugs Acid Straws  
Sinkers

them up while he loaded them. For this he used an envelope and a ball point pen. With the pen he punched several holes into the envelope just large enough for the straws to fit snugly. When he had several upright in the envelope he put it on some newspaper. When he put in the sulfuric acid he didn't want to take a chance on the GOOP not having bonded properly. An acid leak in any one would be disastrous.

With a medicine dropper he got for 30¢ from a drugstore he put in just a little over a half inch of sulfuric acid in each. He had also bought some cotton-tipped Q-Tips at the drugstore. He used one to swab each tube to pick up any acid clinging to the insides above the acid at the lower end.

Next, he stripped off the cotton from one end of the Q-Tip. He separated it into small bits and, with the bare end of the Q-Tip he pushed the cotton down to within an eighth of an inch above the acid. The material to be eaten through as a delay would stop at the cotton.

Clarence tried many delay materials but finally settled on sawdust from dowels, sawed with his metal-cutting hacksaw. He sawed a piece of dowel sidewise and downward until he had a pile of sawdust sufficient for the job. He then folded a small piece of paper and poured some sawdust into its crease. Then he would rest its end on the edge of a straw and flick the paper so the sawdust fell into the straw. When the straw was full to the top Clarence pushed another small wad of cotton in. Otherwise the sawdust would fall out among the matchhead flakes and cause the

bomb to go off too quickly.

He tested several until he knew the acid would take from thirty seconds to a minute and a half to soak through the sawdust and hit the matchhead flakes. This would allow plenty of time after setting the bomb to leave the bar.

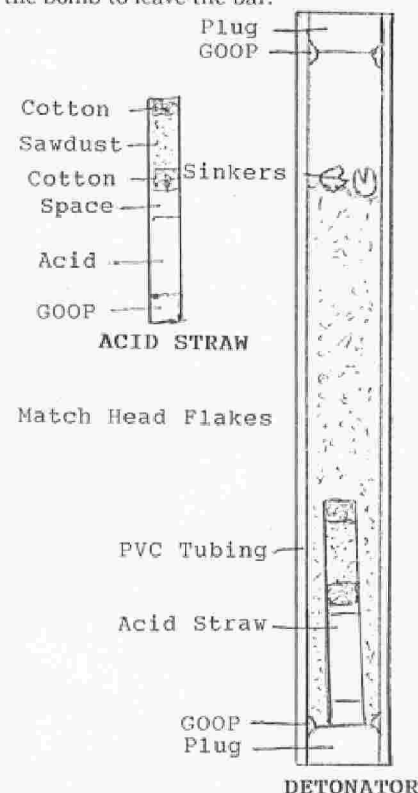

plug. If the bonding wasn't stronger than the tube walls, the plugs would just blow out and there would be no real explosion.

Clarence put a ring of Super-Glu Gel around the middle of one end of a tube and pressed in a plug. He then turned it over and dropped in a detonator, GOOP side down. Next he filled the tube four-fifths with matchhead flakes and dropped in two lead fishing sinkers, size 7. This was so the detonators would sink to the bottom of the cartons, effecting a greater dispersion.

After completing ten detonators Clarence opened the gallon of white enamel and divided it between the ten half-gallon milk cartons. Then he took the two-gallon gas can on a bus to the nearest gas station. He filled it and put it in a shopping bag before boarding the bus home. Since ten half-gallon cartons needed five gallons and the enamel would make up one gallon, he needed a refill. He went to another gas station for that one. Then he filled the ten cartons, allowing room for the detonators, capped them and shook them well. The white enamel caused the gasoline to look exactly like milk.

Then he sat down with his copy of Boy's Night Out and the city map and picked ten bars. His guides helped him to select those most likely to be Martian hangouts. Conveniently, all ten were within a few blocks of each other.

He visited each and walked from the front to the rear looking for exits and logical spots for the placement of the half-gallon gas bombs. Outside of each bar he quickly sketched the interior and marked an X for the placement of the carton.

At nine that evening he loaded his airline bag with five cartons and took a bus to the target area. He got off near the first bar and took out the paper sack hiding the carton. He stuffed it into a nearby trash receptacle and headed to the next bar. He set the next one down in a dark corner of a closed store's doorway. He disposed of two others in a similar manner. The next target was too well lit outside and there were no trash receptacles. So he went inside and hid the bomb in the cleaning supply closet next to the toilets.

He then went back to his room, got the other five and repeated the process. But this time he carried the ten detonators in his belt. They were stable if kept upright. Sulfuric acid is considerably thicker than water and so would not slosh in the straws. They would almost have to be on their sides for the acid to eat into the sawdust.

By 10:30 that night Clarence decided to make his move. His first target seemed to be filling up. He took the milk carton in its paper sack from the trash receptacle and pushed open the bar's door. He threaded his way to the bar and saw three empty

He tested them by turning them upside down in a small pile of matchhead flakes in a small metal bottle cap and watching the second hand of his clock.

Clarence never trusted anything to chance. If a thing had to be done it had to be done right. His psychiatrist had labeled him obsessive-compulsive. He was. He rehearsed everything in his mind and then in practice, over and over again, until it was perfect. He never made a mistake. Like one adept at martial arts, he saw the result of every move before he made it.

Clarence then cut ten five inch long pieces of half inch PVC tubing. Next he cut 20 1/4 inch pieces of half inch dowel. He sanded one edge of each for two reasons. The first was to make them easier to put in the tubing. The second was to have room enough between part of the plug and the tube to allow bonding between the tube, the Super-Glu and the

stools. He took the middle one and sat the sack down at its side.

The bartender approached and Clarence ordered a beer. After paying he sat sipping it slowly while watching the crowd behind him in the mirror on the bar wall. Like most such bars it was dimly lit, so much the better for plotting against Humanity.

He listened as those around him talked. He had been told by guides that every idea that passed between them was a plot and wanted to hear for himself. The two men sitting a few stools down were giggling. One was saying, "That guy gets turned on watching a Preparation-H commercial". The other laughed aloud and Clarence puzzled over what weapon against his people the letter H stood for.

Just then, a friendly fellow sat down beside him and accidentally kicked over the carton of gasoline. Before Clarence could forget himself and bend over to retrieve it the man reached down and picked it up. Clarence was momentarily shaken and took the sack without speaking.

"Sorry about that", said the man. "I didn't see it. I hope it's not damaged".

Clarence untwisted the top of the sack and was relieved that the cap hadn't been loosened. Something about the protective way he handled the carton caused the man to ask, "What's that stuff, anyway?"

Clarence pulled down the edge of the sack, exposing part of the carton in the dim light. "It's milk", he said. "This cat came in off my fire escape and I've been feeding him. Do you like cats?"

The man smiled and said, "No, I hate cats, but--".

Clarence was already upset but now he exploded. Without raising his voice he snarled, "Get away from me!"

The hatred Clarence showed in his face and his voice shocked the man. He arose and moved away, saying, "Pardon me for living".

Clarence just sneered into his beer and muttered, "Not for long, Martian".

After composing himself for a minute he held the sack between his knees, reached into his jacket and pulled out a detonator. He unscrewed the plastic top, turned the detonator upside down and dropped it into the carton. After quickly screwing on the lid to prevent any fumes from escaping he set the half-exposed milk carton on the bar and motioned to the approaching bartender.

"Hey Mister, I'm going out to spit. Don't let anyone steal this milk. And especially my beer. I'll be right back".

"I'll watch it like a hawk", said the bartender, disinterestedly as he went about his business.

Clarence got off the stool and walked with measured steps to the door. When he got outside he

speeded up and was a half block away when he heard a muffled explosion. The bomb had gone off, vaporizing the gasoline and filling the room with gaseous flame. Any inhalation drew living fire deep into the lungs. No one lasted more than a few seconds. Three men managed to stumble outside, torches, falling and writhing and then still.

Clarence scanned his notes on the next target as he turned the corner. He reached into the dark doorway and retrieved the hidden plastic milk carton. The best spot for it was on a table in the middle of the bar. He opened the carton and dropped the detonator in.

He entered the bar and moved purposely toward that table. Three men were sitting there. He said to one, "Hey, be a buddy and watch this for me while I go to the john. Just be a minute".

One of the men nodded and Clarence set the bomb on the table and moved toward the rear of the bar. He passed the toilets and pushed open the exit door. He then ran down the alley toward his next destination two blocks away. The gasoline-filled carton was nestled in a dumpster just down the alley from Target Three.

It wasn't more than five minutes from Target Two and he had the carton loaded and was inside. The key was in the planning, as in Washington. Every move calculated, every route studied and mentally rehearsed.

He went in and elbowed through the dancing men, none of whom gave him more than a glance. He reached the edge of the dance area and set the sack and its carton on a shelf holding decorative plates. Then he wended his way back out the front door and proceeded to Target Four. He wasn't ten feet away this time before the bomb exploded. This was a shock. He must have been slinging with the sawdust. Oh, that must have been during that Roadrunner cartoon. He vowed never to watch TV while making bombs.

When he neared the fourth target he retrieved the bomb from that dark doorway where he'd stashed it, loaded it and went in. He sat the bomb in its sack on the bar and ordered a beer, telling the bartender he'd be right back. He headed toward the toilets and again went out the back and jogged toward Target Five.

Target Five was where he'd hid the bomb inside. He pushed through the now-crowded hallway leading to the toilets and opened the door to the cleaning supplies closet. There was the bomb, still in its sack. He bent his knees slightly and picked it up. The hallway was too dark and too crowded to cause anyone to notice while he opened the carton and dropped in the detonator.

He was also unnoticed as he set the bomb on the table of four visiting female impersonators, the fea-



tured entertainment for that evening. They were all keening their ears to the increasing sounds of fire engines and police cars screaming by outside. Clarence pushed his way through the knot of men blocking the door and headed toward Target Six.

It was in the opposite direction from where the sirens were heading but he had to hurry. There was no communication between the bars. Certainly no one in those destroyed had had time to call around. And the authorities would need time to sort things out and establish a pattern.

Target Six was three blocks away. Clarence turned into an alley and ran as fast as he could. His route took him down three blocks of alleys and half a block over. He snatched the carton from its trash receptacle, loaded it and pushed open the bar's door. There was no sign of alarm. He went in and placed the bomb on the far end of the bar counter and exited out the back. He sprinted back to the alley and ran two blocks to Target Seven. When he got to the sidewalk he could hear sirens but could see no fire engines or patrol cars.

He took the bomb from the doorway three doors down and loaded it just as he approached the entrance. He went in and sat it down just inside the entryway and, since there was such a crowd and no one could make out anything in the near-darkness, he simply went back out.

Target Eight was four blocks away and Clarence was getting winded. He broke into an Indian lope and got his second wind as he entered the bar. He had put the bomb in the toilet behind the towel-disposal can. He picked it up and carried it out, unnoticed. These bar patrons were pretty high and would have helped him load and place the bomb if he'd asked.

When he walked out and headed to Target Nine he told his guides he was too tired to go on. They gave him a pep talk and he felt encouraged. He was advised, also, that if a bomb were left, someone might put two and two together. He answered that the last two were in trash cans and would be carried to the dump. The guides ordered him to proceed and, like a good Earth soldier, he obeyed.

Target Nine was a cinch. Its patrons were just standing around and the wall areas were crowded and there were no tables. Clarence took a chance and simply set the bomb down by a pole support in the middle of the room. As he walked out the rear exit the bomb exploded and he could feel its concussion, just in front of its flames, on his back. "That settles it", he said to his guides, "No more TV while on duty".

Bar Ten was the last. By this time the whole area was in pandemonium. The surrounding blocks were being cordoned off and policemen on foot were herding people out of the neighborhood.

Bar Ten was also a leather bar. Clarence guessed as he noticed the patrons dressed like the bikers in *The Wild One*, starring Marlon Brando and Mary Murphy. Mary Murphy wasn't in sight.

This one was one of the darkest so Clarence felt at ease placing the bomb at the end of the bar at the far wall. Just at that moment an excited cop opened the front door and yelled, "Everybody out. Clear this bar".

The macho, anti-cop crowd just yelled back insults. As Clarence made his way out the back he yelled, "Lousy pigs, this is our place. Leave us alone".

Clarence didn't hear the cop scream, "Bars are being blown up all over the place. You're going to fry".

By the time some of the louts were paying attention, the room was engulfed in flames. The cop was lucky enough to leap to the side as the rush of flame billowed out the open door. Some of the leather-jacketed patrons managed to reach the door but they were soaked and burning. None lived long enough to get to the hospital.

Clarence walked down the alley, relieved that his job was over. He got to the street and noticed that several bars up further were emptying. The sidewalks were filled with gawkers and the streets were crowded with fire engines, police cars and ambulances. The latter were no help to anyone.

Clarence had to walk ten blocks before he could get to a street where busses were still running. It was 1:30 A.M. before he got to his room. The cat was clawing at the window and Clarence let him in and opened a can of Sheba.

He watched the news reports throughout the night. There was panic among homosexuals. Carloads were leaving New York. They knew they were somehow targeted but had no idea why.

The police had no leads; no suspects. The public was assured there was no connection between what had happened in Washington and New York. Moslem fundamentalists were not to blame.

The ATF and FBI were combing the area and checking on every anti-homosexual group, mainly Christian fundamentalists. Nothing.

Clarence knew there would be no breaks in the case. Certainly no Martians would tell and thus give themselves away. He was engaged in a war where no friends even knew there was an enemy. He, the only one fighting for them, dared not reveal himself, lest he get sent back to that place. It would be a long, hard war.

## ALL MUGGERS ARE MARTIANS

by Kurt Saxon

Ten Martian recruiting centers had been turned into infernos. There was little else in the news. Clarence watched the accounts hour after hour as the body count rose to 732.

The police boasted several leads and promised to bring the homophobic monsters to justice.

It was with great satisfaction that Clarence turned off the TV and took a walk down the street of his seedy neighborhood. As he listened to his guides praising him for his fine work he didn't notice the three young black males crossing the street to intercept him.

Clarence swerved to walk around them but they blocked his path. "We want your money, Suckah", said one.

Clarence was astonished, as he had never had trouble with blacks. He refused to give them anything.

One lashed out with a balled fist to his stomach. As he bent over another slammed a fist into the side of his head. When he hit the sidewalk all three began to kick and punch until Clarence could offer no resistance.

When they searched him they found only six dollars. "You dumb mothuh", screamed one, "Only six dollars? You took a beatin' like that for six lousy bucks?"

Half conscious, Clarence replied groggily, "I thought you were after the two hundred dollars in my shoe".

As he limped back to his room, Clarence talked over the mugging with his guides. It was obvious that the mugging was no coincidence. They had to be Martians.

That they were assuming the forms of Blacks caused Clarence to remember Josh, his black friend and almost father back at the hospital. Josh was the only one besides himself who knew of the Martian invasion.

He had spent many happy hours with Josh as the elderly black leafed through a Rorschach inkblot book he had carried away with him after his last session with his psychiatrist. Josh believed it to be his own family photo album. "Now here's me an' the missus at the beach last summer". Clarence humored him as Josh would identify another inkblot as his youngest girl. Clarence knew that one was no little girl. It was plain to Clarence that it was actually a Martian eating an ice cream cone. But he never let on to Josh.

Since Clarence had attracted Martian muggers, his guides suggested he make it a habit. He would rid the black community of Martians. He would do it for Josh.

When he got back to his room he fed the cat and went to bed. Next morning he was sore and broke. Luckily, he had bought several cans of Sheba for the cat and some canned food for himself. They would have to go without milk, though. Even so, his next SSI check was over two weeks away so he'd have to get some money. Well, Martian muggers would have all the money he needed.

But right now he had no weapons and no money to buy the makings. He did have about an ounce of super-strong ammonia distilled from store ammonia, (page 18) which he had

sucked up into a Vicks Nasal Inhaler. This was a devastating weapon. A shot in the face would instantly put anyone out of action for at least five minutes.

That would come in handy but he wanted something to hit with. He walked down the block to a garage and service station and went around back. After a few minutes of searching the ground he found a lug nut.

When he got back to his room he rummaged through his equipment and found a foot-long piece of half-inch dowel and cut it in half. He next sawed a half-inch slit down the middle of one end. Then he forced the end of a length of heavy cord into the slit, wound it around several times, drew it under one of the strands and tightened it. He then tied the lug nut six inches from the dowel.

He had to rest and heal another day before he could go hunting so he spent the time practicing. He had secured a pillow head-high on the open closet door. With the lug nut and the dowel in his shirt pocket, he would face the pillow, grasp the protruding dowel and flick the lug nut out at the pillow.

After a few hours of practice he could hit any point on the pillow within an inch. He could reach for the dowel and strike in less than a second. He was ready.

He rested up all of that day and the next. Then, after sundown he went hunting. He hoped to meet the three Martians who had mugged him but that was hardly likely.

About ten blocks into the darker section of his neighborhood he was confronted by two blacks who were almost businesslike. The one on his right had a pistol and the other showed Clarence a knife. After the usual demand, Clarence said to the gunman, "Who should I give the money to? This other guy looks like a criminal. I wouldn't trust him if I were you".

As he said this, the gunman glanced at his partner, grinning at such stupidity. As he did as expected, Clarence snatched the dowel and, in one swift movement, swung the lug nut at the gunman's temple. It half buried itself in his skull and he buckled.

Even as he swung, Clarence had the opened inhaler in his left hand and sprayed the knife man full in the face. The knife dropped and the blinded, agonized mugger whirled around screaming. Clarence picked up the pistol and shot him to end his misery.

He then searched both muggers and collected \$184.63. As he walked away, he said to his guides, "Get back to Josh and tell him there are two less Martians masquerading as his people".

Clarence decided to call it a night, as he was still stiff and sore from the beating. He went back to his room and bought more milk for the cat along the way.

In his room, he examined the pistol and found it had only four bullets. That would be a problem. There was no way he could buy bullets in New York, at least not for a pistol. He

would have to find a source or make a shotgun, since he knew he could buy shotgun shells.

The next night he walked about twenty blocks before he saw what might be Martians. Two blacks were dragging a young woman into a doorway near a bus stop. They hadn't seen Clarence. The young woman had screamed once but then further screams were muffled.

Clarence drew his gun and rushed to the doorway. The men were in the act of pulling her skirt off when Clarence appeared and shot one. The black holding her put his arm around her throat and pointed a pistol at her head.

Then he said to Clarence, "Throw down that gun and get out of here or I'll kill you".

Clarence couldn't help laughing. "Why, you must be catatonic. Your gun is pointed at her so I'd have you shot before you could point it at me. Drop the gun right now or I'll kill you!"

"If you shoot, you'll hit her", argued her captor, ducking his head behind the head of the young woman.

"If I shoot her, you can't very well use her as a shield", said Clarence. "So drop the gun; I'm busy".

The black seemed to think a moment, then dropped the gun, let loose of the young woman and started to walk away. Clarence shot him in the face.

The young woman began to blubber and Clarence told her to shut up and get dressed, as he searched both of the bodies. When he'd taken their wallets and the pistol he led the young woman back to the bus stop.

He asked her why she was in this neighborhood and she said she'd fallen asleep and gone past her stop. As he put her on the bus going back she asked, "Who are you? What's your name?"

Clarence answered, "I'm just a soldier in the army of the unseen, Miss. We don't have names".

When he got back to his room he opened the wallets and found he had earned \$137.00. He decided that killing Martian muggers could turn into a good living.

The next came upon an I.D. card issued to New Yorkers who didn't drive. This had belonged to the one with the gun. Unlike the first gun, which was an automatic, the gun he took from the rapist was a .38 Police Special with five bullets. Clarence liked the .38 better and one of his guides gave him an idea of how he could get more bullets.

He would go to the address on the I.D. and get the bullets the owner must have had more of. It was bold, but he might flush out yet another nest of Martians.

The next evening he took a bus and got off near the address. He found the tenement building and walked up the three flights of stairs. When he got to the apartment number he knocked.

The door was opened by a surly teenager who looked like a mugger himself but didn't seem to be a Martian. The lad was about to slam the door in Clarence's face but Clarence forced it open.

"Who are you, Honkey? You a cop?", shouted the boy.

"No", said Clarence, pointing his pistol at the boy's face. "I came to get the bullets for this gun. I have enough to finish you and anyone in this place so don't get cute".

The boy backed up and led Clarence into a room at the back of the apartment. It was a bedroom with stacks of unopened TV and VCR cartons along the walls. It all looked like loot to Clarence and he watched closely as the boy rummaged through dressers and found a box of .38 cartridges.

The boy was obviously obeying out of fright, but as he handed Clarence the box he examined the gun. "That's Johnny's gun", he said. "The only way you could have gotten that and to know to come here was to kill Johnny". Then he yelled, "There's a whitey here with Johnny's gun. He's killed Johnny".

A scream echoed from the next room and a large female lumbered down the hall to the bedroom as Clarence made his way to the door. She blocked his way and the boy, emboldened by rage and grief at the loss of his brother, slid around his mother and blocked the door.

"You killed my boy?", she roared. "You killed my boy!"

The lad then yelled, "Get the butcher knife, Mamma. Cut this honkey to bits".

The woman turned and rushed into the kitchen as Clarence tried to force his way past the boy to get at the door. Before he could get out, the woman charged with the knife in front of her, meaning to impale Clarence with the force of her large body as she continued to bellow, "You killed my boy. You killed my boy".

Clarence had no hope of disarming her. Almost on reflex he grabbed the boy and spun around with him and the woman buried the knife in her son's chest.

What with all the screaming and yelling from both mother and son, Clarence was able to open the door and flee down the hall. As he left the building, he answered one of his guides, "Yes, they're a noisy people. But what's worse, they hold a grudge".

He had dropped the box of bullets at the door and was in a foul mood. He blamed the botched mission on his guides. As he walked to the bus line he told them, "It's all your fault. You came up with that stupid plan. Dumb. Dumb. Dumb".

"Besides, they weren't even Martians. Simple rapists and thieves our only haul in two nights. And I lost the bullets and there's only five left in this gun".

He continued to argue as he boarded the bus. Although he lowered his voice, his muttering caused the other passengers to stare, as he was the only white person on the bus. He stared back and as he did so he noticed three men a few seats behind him.

They were the ones who had mugged him. It was no coincidence. They were following him. They must have known what he'd just done. He'd have to get rid of them. He stared straight at them and they recognized him.

He kept staring until he neared his stop, then, continuing to stare over his shoulder, he went toward the front exit. One of the muggers nudged the other and the three got up and waited at the middle exit, as Clarence expected.

When they all got off the bus, Clarence hurried down the street. They thought he was trying to get away but he only wanted to get away from the well-lighted main street.

The muggers hurried also and when they caught up to him one said, "Hey, Mothuh, you got another two hundred dollahs in your shoe?" The three laughed and then stopped laughing when Clarence spun around and pointed his pistol.

Their leader said, "No fair, Mistah, we ain't armed".

Clarence calmly and quickly put a round into each chest and sent the last two into the heads of two still flopping. He quickly took their wallets and left the pistol in the hand of one.

Back at his room he counted the money from the wallets. He had earned \$362.00. Actually, counting the \$200.00 he had lost to them, only \$162.00. But those were the breaks.

One thing he resolved was to drop his dependence on Smith & Wesson. He'd make his own guns from now on. He decided on an improvised shotgun. (See page 11). Cheap, no ballistics, simple parts and ammunition easy to get without signing, at least outside New York City. He'd been reading gun magazines and knew that #1 Buckshot shells held 16 .30 caliber pellets, the most destructive load available to civilians.

Next day he went to a large hardware store and bought six feet of 1 inch steel plumbing pipe and had it cut into 6 inch lengths, each piece threaded at one end. The clerk, just out of curiosity, asked what he wanted it for. Clarence answered that he didn't know as he was getting it for his landlord.

He then bought 12 1 inch pipe caps and two 6 foot lengths of 3/4 inch pipe.

When he had lugged the hardware and the remaining odds and ends up to his room he set about sawing the 3/4 inch pipes into 10 inch lengths.

After he had made 12 guns, he took the Metro to Brewster. He went into a sporting goods store and asked the clerk where the nearest shooting range was so he could practice with his shotgun. The clerk gave him a location and Clarence asked for eight boxes of single ought Buckshot. He presented his state I.D. card but the clerk wasn't interested.

That evening he felt the need to test the gun. There was a basement in the apartment building but he didn't want to attract attention with the noise. What with backfires and shootings being common in the neighborhood he decided to test the gun around the corner.

When he got to the darkest part of the street, Clarence put the pipe cap against his stomach and slammed the barrel back. The shell exploded and the recoil nearly knocked him down and certainly knocked the wind out of him.

That was no good. Had he been holding the 6 inch pipe in one hand he wouldn't have been able to keep his grip. Nor could he risk staggering around trying to regain his breath. He had to make something to absorb the recoil.

Also, the heat from the shell came up through the handle and burned his hand. Not enough to blister, but it did hurt. Moreover, it would leave powder flecks on his right hand. There was little chance of his being tested for firing a gun but he'd better solve those problems.

He had looked around the basement while he and his guides talked over the testing. He remembered some old sponge rubber mattresses in one corner. He went down and cut a square foot from one, along with an odd piece of 1/4 inch plywood and took them up to his room.

He cut an 8 X 8 inch square from the plywood and rounded its corners. He then cut the piece of mattress to the same size. He used GOOP to glue on the plywood and now had a 4 1/2 inch thick pad with the plywood rest to absorb the recoil.

Next he cut a 4 inch square by 1 inch thick piece of mattress and made a slit in its middle. This he slipped over the barrel to absorb any heat and powder specks coming up through the handle. He made three more as spares.

Clarence spent the next day feeding the cat, watching TV and practicing loading, drawing, stripping off the duct tape, dry-firing with a spent shell and disassembling the shotgun. He got so he could fire, disassemble and throw the pieces in all directions in under 10 seconds, just in case a patrol car should come into view.

That night he put the pad, plywood side out, inside his jacket over his stomach. It gave him a bit of a pot-belly but wasn't too noticeable. He'd cut a pocket-sized slit in the jacket a few inches to the right of the zipper. Through this slit he pushed one of the guns and lodged it at the top of the pad.

He put one gun in each of his pants pockets and another into his right jacket pocket he had lengthened to keep it out of sight. He also put a dozen shells into his left jacket pocket. Then the one-man-army went out into the dark street hunting for Martians.

He walked fifteen blocks, floating on air despite the weight. He was so happy that he had the perfect weapon to rid the planet of at least 199 of them. But of course, he could go back to Brewster and get eight more boxes.

As he was fantasizing thusly, three blacks turned the corner and nearly bumped into him. They could have gone around but stopped and barred his way.

Clarence looked up and down the street and one of the blacks said, "No use, man, there's no cops anywhere around". "This is our hood, Baby", said a second.

Clarence was looking for cops, but was relieved not to see any and was glad of the black's reassurance. The third black pulled a gun and held it sideways, taunting Clarence. "Now, this here's a forty-five caliber automatic. It's for killin' white fools who come into our hood and don't turn over their money fast. And maybe even if they do turn it over. What do you think, Fool?"

"Well", said Clarence, drawing his own through the slit in his jacket, "I don't think a forty-five caliber bullet compares with a twelve gauge, single-ought with sixteen thirty caliber pellets".

The black took a moment to examine the weapon as Clarence pulled off the strip of duct tape, pulled the barrel out an inch and slammed it back. It went off with a roar and a flash pointed at the man's chin. It turned his face to hamburger and he vaulted back as if hit by a sledgehammer.

Before the other two could react, Clarence changed his grip on the barrel, jerked it out of the handle and smashed it into the temple of one. The third mugger took off and Clarence dropped the pieces and went for the gun in his right pocket. He rested the handle on his front again, took aim and slammed the barrel home. The last mugger was thirty-five yards away when at least six of the sixteen pellets ripped into the back of his head and body. He went down on his face and twitched as Clarence took the wallets from the two nearest and picked up the pieces of the first gun. Then he loped to the first mugger, took his wallet and went down an alley to relax and reload.

As he replaced the shells and put on two more strips of duct tape, which he had stuck to the plywood on his padding, he marveled at the gun's performance. It was quick and devastating and the pad had absorbed the recoil. It was ever so much better than any gun he had taken. He hadn't even bothered to pick up the .45. So much for trashy weapons.

With four guns back in place, Clarence continued deeper into the ghetto. Ordinarily this would not have been the best hunting ground for muggers, as they would be working better neighborhoods. But neither Clarence nor his guides were wise enough to know this. Even so, a young, pot-bellied white man was a good target for muggers on their way to work.

As Clarence walked along he noticed a young white man coming his way. The fellow had long hair, an earring, a beard and wore jeans torn at the knees; a real scuzzbag. Even so, Clarence thought it best to warn him.

"Say, Mister", he said as the man neared, "This is the wrong neighborhood for whites. There are muggers around here".

The scuzzbag stopped about a yard from Clarence. "That's okay", he said. "I mug niggers".

"You what?", asked Clarence, astonished.

"I mug niggers", he repeated. "Of course, I ain't prejudiced; I mug whites, too, and spiks. As a matter of fact, I'm muggin' you, so hand over your wallet". The scuzzbag snapped open a switch blade and waved it under Clarence's nose.

The white mugger didn't look like a Martian, but then again, who did? Clarence pulled a gun from his jacket, stripped off the duct tape and blew the surprised scuzzbag's face away.

It was nearly midnight and Clarence decided to ride back to his room. He walked four blocks to a thoroughfare and boarded a nearly empty bus. A block later two blacks got on and sat in the seats in front of Clarence.

As they rode they talked openly about going to Central Park where the pickings were easy. Clarence listened as his guides mapped out a new program for him. Instead of using him as bait, they would let him interrupt muggings. Clarence liked the idea.

He was tired but excited at the prospect of actively protecting people from Martians. He rode with the two muggers until they changed busses. He changed with them and they didn't seem to notice.

The two got off at Central park and Clarence got off a block further. He noticed which path they took and doubled back to

follow them. The park was nearly deserted at this time of night but two tourists, so stupid as to be asking for it were about to get it.

Clarence saw the two waylay the tourists and draw guns. He left the path and sprinted toward them behind a line of bushes. As the man was handing over his wallet and the woman was emptying her purse, Clarence quickly stripped the duct tape from two guns.

He shot through the bushes, downing one of the muggers and quickly picked up the other gun. The blast of the shotgun shell rang through the area, the remaining mugger looked all over for its origin, not knowing where to shoot or where to run.

The woman tourist clung to her husband and, as they were out of the line of fire, Clarence fired again, nearly cutting the other mugger in half. As the tourists stood frozen in shock, Clarence commanded through the bushes, "Get out of the park, right now. Go!"

The tourists came back to life and the husband dragged his wife toward the exit, leaving one of her shoes behind. Clarence came out of the bushes and lifted the wallets of the muggers.

Clarence quickly reloaded and left the park, never getting back on a path. Rather than wait around for a bus, he went down the subway stairs. He got on the first train and walked through the nearly empty cars until he came to the last one.

He sat down and looked out the window at the street signs illuminated on the sides of the tunnel. He was going the wrong way but he didn't worry. Seeing him sitting alone, two more muggers cruising the cars approached him. Clarence slipped the gun from the slit in his jacket. As the lead mugger flashed his knife, Clarence's gun flashed and the mugger's insides made a mess of that end of the car. Clarence leaped up with the barrel and smashed it into the head of the other mugger.

He then lifted their wallets, fat from the night's take. There were no witnesses, as the last car was empty. Despite the noise, the rattle of the subway train kept the few passengers in the other cars from hearing it. Clarence got off at the next stop.

From there, Clarence made his way to his room, fed the cat and watched TV through the night. The media was already picking up the stories of people being shotgunned over a wide area. That the victims were muggers, there was no doubt, even without positive I.D.s.

As yet, there was no media panic, since only eight muggers had been killed, this night. There was no mention of the two muggers and two rapists he'd taken care of two nights ago. Clarence counted his money and found he had more than a thousand dollars so he decided to stop taking wallets.

The next evening he went cruising again and got six more. Eight the next evening and only three the next. After a week, enough bodies of muggers were turning up in subways, parks and side streets to finally alarm the media.

The media, in turn, alarmed the muggers. Clarence had slimmer pickings from then on. Fewer muggers mugging made for a boring routine. Clarence would have to find different targets. He opened another can of Sheba for the cat and turned on his trusty little TV.



## RADIO BEAMS FROM MARS

by Kurt Saxon

For several days and nights Clarence stayed glued to his TV set. Countless cartoons, talk shows, movies and news reports were without a single message for him. And one evening it happened.

A news segment on animal rights activists featured their spokesman, Sonny Barlow, showing clips of animal torture by cosmetics companies. Rabbits were shown, strapped down while various cosmetics were put in their eyes. The purpose was to see if their eyes would be damaged. If not, the eye cosmetics and shampoos would be safe for humans.

Sonny ended his short talk with, "One would have to be from outer space to not know this is the willful torture of helpless animals".

Clarence had watched in horror. He had not imagined such cruelty. There had been cages holding cats in the same room. He pictured in his mind his cat in one of those cages awaiting some awful experiment.

As he thought about it he grew enraged and tearful. He looked over at his cat and the cat looked back at him. His guides assured him that those monsters would get around to his cat in time.

"But they won't", shouted Clarence. "They're Martians, all right. The man said you would have to be from outer space not to know it was torture. Of course they're from outer space. So they're our next targets".

He discussed the matter through the night with his guides. Clarence was willing to kill anyone connected with such brutality. But it wasn't as simple as that. These were businesses, with mainly Earth people duped into doing the dirty work. He would kill a dozen employees without getting to one Martian.

So how to ruin the Martians' business? The main culprit Barlow named was Tressallure. This was a hair cosmetic firm which come out of nowhere to flood the TV with dazzling commercials. Tressallure was owned by Vito Benno, a greasy slug said to have mob connections.

As Clarence and his guides discussed Tressallure, one of the guides brought up Milton, the electro-chemist back at the hospital, Milton had refused to use shampoo and would only wash his hair with soap. He had assured Clarence that the pyrithione zinc in most shampoos made the scalp a conductor. Space people could then beam their messages to those zinc-coated skulls and cause those people to vote for politicians who were actually space people up to no good.

"The best way to stop that is to make people afraid to buy Tressallure", said Clarence to his guides. "That

would not only stop the Martian radio beams but would stop the torture of rabbits and cats".

After more discussion they hit upon the idea of buying two hundred bottles of Tressallure and substituting hair remover for the shampoo. Clarence decided to doctor the two hundred bottles of Tressallure with hair remover. That would cost maybe \$2,000.

He needed nearly \$1,000 so he loaded up four pipe shotguns and went hunting for Martian muggers that night. With his padding to rest the handle of the gun on, he looked sort of fat, and being loaded down, a little drunk.

After a few blocks into the rougher part of his neighborhood he was approached by two blacks who saw him as an easy mark. Clarence pretended to scratch himself and put his hand through the slit in his jacket.

Neither of the two blacks even pulled a weapon, thinking Clarence was that easy. When they stopped in front of him and demanded his money Clarence pulled out the gun, rested its handle on the padding and fired. Sixteen .30 caliber pellets ripped into the throat of one, nearly tearing his head off. Clarence quickly pulled out the barrel and smashed it into the skull of the other.

He took his time searching the bodies on the dark street. These two had been at work. He collected over \$400.00. Since it was only 10 o'clock, Clarence stayed out hunting. He no longer enjoyed it. He had gotten so skilled at spotting, attracting and killing muggers it had become boring.

The next morning newspaper headlines screamed, "SHOTGUN VIGILANTE SLAYS 8 MORE!" The TV gave his night's work full coverage. Commentators accused the police of laxity and demanded troops to protect New Yorkers from the killer of muggers.

That afternoon Clarence walked to the drug store and bought one bottle of Tressallure and one of a popular lotion hair remover. It was for coarse, dark hair, supposedly the strongest. He had intended to mix it half and half and so he smeared a generous helping of the mixture on one arm and let it alone for five minutes. When he scraped it off he was disappointed to see it didn't work.

So much for that. He'd have to use it full strength. He then put the pure lotion on his arm and, sure enough, all the hair in that spot came off at the roots after five minutes.

Clarence reasoned that since Tressallure was a relatively new product, people wouldn't know what to expect. They'd just rub it in like their regular shampoo, usually while in the shower, or even over a sink. Then



after a few minutes they'd try for lather, of which there was none, and rinse it out; along with their hair.

Clarence bought two hundred twelve ounce bottles of Tressallure and four hundred six ounce bottles of the lotion hair remover. This took him five days as he visited six hundred drug stores, mom and pops and supermarkets in a ten square mile area. It cost him nearly all he had, but easy come, easy go.

To avoid suspicion, although he could have bought a dozen bottles without arousing comment, Clarence bought one at a time. He was methodical to the extreme. He would buy a bottle, stick it in a pocket in its sack with receipt and go on until front, back and jacket pockets were filled. When he had six, he would go to a trash receptacle, find a dirty sack and put the six bottles in it and stuff it down in the receptacle. When he had five sacks of six bottles each he'd go back and collect them and take the thirty bottles back to his room.

After twenty trips he set to work emptying the Tressallure down the sink and refilling the bottles with the lotion hair remover. He had bought a pair of rubber gloves at a pharmacy and was careful to wipe off any fingerprints. He also made sure to put each Tressallure bottle back in its original marked sack so it would go back to the store he bought it from.

When he had the two hundred bottles filled he made the rounds, going into each store and putting its bottle or bottles of Tressallure back among the rest, up front.

Molly Franklin was coming out. She expected to see Todd Jordan at the ball this evening. He had twenty million and she wanted it. Her parents had pulled a lot of strings to get Todd to the coming out. She was pretty enough, but with Tressallure (she believed commercials), she was a cinch.

She undressed and stepped into the shower. The Tressallure had a different smell from most shampoos she'd used, but so what? She massaged it in, took the bar of Lady Beauty soap and commenced to soap herself all over while the Tressallure worked its magic. She luxuriated for several minutes while bathing then stood on one foot, then the other, making sure she got between her toes clean.

Then she turned the faucet on full and bent her head, eyes closed. She then directed the spray to her underarms and the rest of her. As she rinsed out her eyes she noticed the water coming up over her ankles and begin to flow out under the shower door. She looked closer and noticed the drain clogged with hair. She screamed.

Her mother fainted when Molly appeared in a towel, shrieking hysterically. Only a few dripping wisps were left. "I can't go", yelled Molly. "I don't even have a wig. Now that slut, Angela, will get him".

Mr. Franklin examined the Tressallure bottle and

had his now recovered wife search out the receipt. That snot Todd's twenty million was chickenfeed compared to what he could get from Safeway and Tressallure.

By noon the next day an alert had gone out over every radio and TV station. Within hours Tressallure was being taken off the shelves of every store in the city. Then it was statewide. The networks joined in and by that evening Tressallure was pulled from every store nationwide.

Eighteen lawsuits were filed in the next three days. Then the phenomena began. The networks had described the substitution as a matter of course. Hundreds of persons around the country were turning in bottles of Tressallure they had bought before the recall and filing suits.

Anyone willing to lose his or her hair in expectation of collecting big in court was claiming his or her bottle had been spiked with hair remover. Even other shampoos were affected, as all one needed was any shampoo bottle filled with hair remover, even without a receipt. Within another week there was no shampoo of any kind for sale.

Vito Benno was hunted down by the media and found in a massage parlor. His attorney was with him and nervously advised him not to make any statements. Vito Benno waved him aside and shouted, "You call this justice? I hire the best looking broads for my TV commercials, with the nicest hair. I even hired a nigger teenager to tell those broads to shake their bodies for him, like in the Revlon commercials. Who says I ain't got class?" His lawyer left the room.

Then Vito Benno began to weep. He swept the toupee off his head and used it to wipe his eyes. Then he blew his nose in it. "Just because we blinded some rabbits those animal activist freaks gotta go and put me out of business. I'll get them, see if I don't".

The next evening Sonny Barlow was found shot dead. Everyone suspected Vito Benno but two women swore they were in bed with him at the time. Vito Benno had mob connections but nothing could be proven.

When his TV informed him of Sonny Barlow's death, Clarence was shattered. He had caused the death of another human being! He wept with shame and re-remination.

But he would avenge Sonny Barlow. Vito Benno was a Martian and so would have to die. But how? Clarence didn't know where Vito Benno lived and supposed he would be guarded, anyway.

He would have to draw Vito Benno into the open and in a situation where he could be gotten at without much risk. His guides came up with a plan to burn Vito Benno's warehouse, thus getting him into the open as a spectator.

But first, Clarence needed a weapon which was

easily concealed, not too noisy and disposable. One of his guides suggested an icepick. This was logical, since an ice pick would be silent and would produce a small but deep wound. Clarence liked the idea but naturally improved on it.

He went to a dime store and bought two wooden-handled ice picks and a packet of large fish hooks, size 5/0. When he got to his room he tried to pull the picks from their handles. They were in too tight so he put a knife blade alongside the pick and whacked it with a pair of pliers. The handle split and he took the pick out. He then put a piece of match stick in the slot so the pick wouldn't go in farther than three eighths of an inch.

Next he bent back two of the fish hooks until they broke. He used GOOP to glue their points onto the points of the picks. Then he used more GOOP to glue the handles back together. He then whittled the pick ends of the handles to within a sixteenth of an inch of the pick. Thus, he had the absolutely perfect murder weapon.

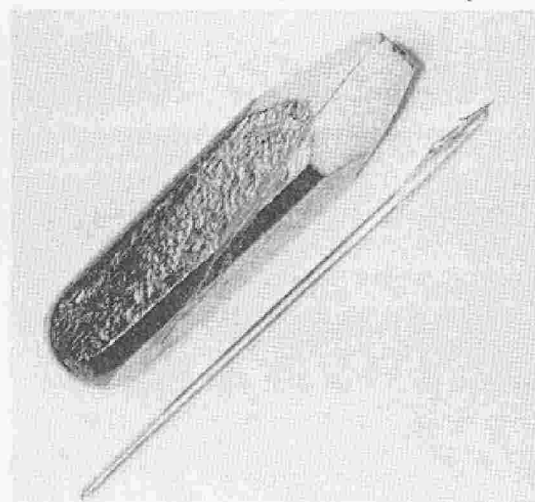

At the hospital he had often discussed surgery with Dr. Blount, a fellow patient and defrocked surgeon. Dr. Blount had taken to searching for CIA electronic implants during routine surgery. He had told Clarence how the body tissues tended to instantly close in around wounds. Clarence also remembered how in war movies, a soldier often had to use his foot on an enemy while withdrawing a bayonet.

The pick would stay in the handle but was plenty loose enough to stay in a body after entering. Nonetheless, Clarence put the pick point-up in his shirt pocket and the handle in his jacket pocket. He then went to Central Park looking for someone to test it out on.

As he stopped to watch some children at play, he

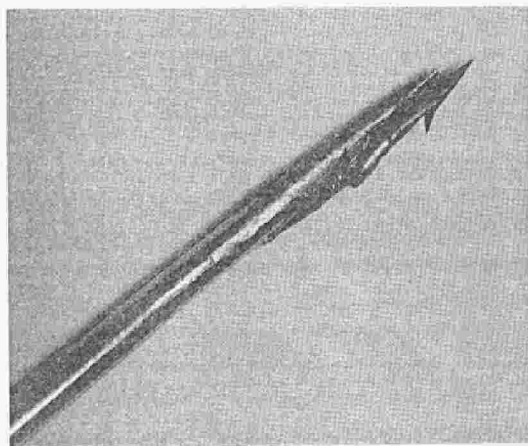

heard a small voice at his side. "Hey, Mister". He looked down and there was a little girl. He was amazed that he could see right through her.

He called her to the attention of his guides and was told that they couldn't see her at all. One even accused him of hallucinating. Clarence was angered and protested that he didn't hallucinate. "What do you think I am, crazy?"

He turned back to the little girl and she said, "That man over there on the bench did bad things to me and then he choked me".

So she was a ghost. Clarence had never seen a ghost

but didn't doubt the child. Still, not one to overreact, he watched the man the little girl had pointed out before taking any action.

The man was watching the children intently. One of the girls called another little girl by name, "Margie". The man stood up and approached Margie. "Margie", he said, "your mother's been hurt and she wants me to take you to her".

The little girl burst into tears and asked, "Is Mommy hurt bad?"

The man answered, "Pretty bad. So you'd better come along now". He reached out his hand and Margie took it and the man proceeded to lead her out of the park.

Clarence had heard it all. He took the pick out of his shirt pocket and inserted its end into the handle. He followed the two a few paces and as he got alongside the man he plunged the ice pick into his side, below the ribs, with enough force to cause the handle to push the flesh a couple of inches inward.

When the handle was pulled away the pick stayed deep inside the body, held partly by the 5/0 fish hook. As the flesh rebounded, it closed over the end of the pick. There was hardly any blood and little appearance of a wound, especially since what wound there was was covered by clothing.

Medics just coming on the scene would be hard put to find the wound and it would certainly be fatal before any sort of surgery could remove the pick. It had also passed through organs and intestines, making dozens of holes which could not have been mended in time.

The man screamed, clutched his side, staggered around for awhile and fell to the ground writhing, Margie had no idea of what had happened but stood apart, worrying about her mother. Clarence stepped away unnoticed. The little girl had disappeared.

A small crowd finally gathered around the man as Clarence stood and watched. The man could have been drunk, doped, epileptic. There was no sign of an injury. One concerned comforter relieved the man of his wallet. Another took his wristwatch. After a half hour, medics appeared to take away the corpse.

Clarence was satisfied. On the way back to his room he went to a drugstore and bought a two-liter enema bag. Then he called the Tressallure company. When the receptionist answered, Clarence said, "Hey, Babe, I've got a load of Tressallure from Nevada and the bill of lading got coffee spilled on it. I can't read the address. What's your warehouse address?"

The receptionist rummaged around and finally told him where the warehouse was. Clarence then took a bus to the address and found it was an old warehouse down near the docks. He had expected to need a cordless drill to make a hole in the wood or metal front to stick the

enema bag tube through.

He was lucky, since the warehouse, old but sturdy, had several slits as wide as a half-inch. The warehouse was nearly full of cartons of returned Tressallure. There was nothing else there, since the product was put up by a commercial bottling plant elsewhere.

Clarence went back into his room and waited until near dark before taking the bus again. This time he carried the enema bag by a cord around his neck, under his jacket, filled with two liters of gasoline.

There was no one around so he stuck the bag's tube through a crack and pressed the bag. The gasoline squirted several feet into the warehouse. Clarence made sure to ease up near the last so there would be a gasoline trail up to the crack.

Then he lit a match, thrust it through the crack and walked away. The two liters of gasoline made a glorious fire, which wouldn't be noticed for several minutes. He disposed of the enema bag.

Clarence then went to the nearest fire alarm and set it off. He then went to a public phone and called the Tressallure office. He expected an answering machine but someone was still there. He reported the fire, saying he was with the Fire Department. He suggested that Vito Benno should be notified and told to go to the warehouse.

Clarence sat in a nearby coffee shop until the fire trucks arrived. Then he ambled back to make up part of the small crowd collecting.

The firemen didn't seem much interested in Vito Benno's warehouse, probably because the plastic bottles in the cartons were such good fuel. While they concentrated on keeping the fire from spreading to the nearby buildings, Vito Benno was driven up. He and two obvious bodyguards poured out of the limo and Vito Benno commenced to scream hysterically at the firemen.

While the bodyguards looked around for recognizable enemies, Clarence edged near and plunged the ice pick into Vito Benno's side. As Vito Benno gasped, Clarence flicked the handle to the ground and looked at his victim as would any bystander. Vito Benno clutched his side and his bodyguards quickly looked him over for any signs of a wound.

His suit jacket showed no holes and Clarence told one of the bodyguards, "This man's having a heart attack or a stroke or something. I don't like his color. You shouldn't let him get so excited".

The bodyguards just scowled at Clarence and half-carried Vito Benno back to his car. That evening the TV announced Vito Benno's death, speculating it was a mob hit. The anchorman explained that Vito Benno had probably borrowed millions of mob money and couldn't begin to pay it back. That sounded reasonable to Clarence

Clarence then settled back to watch his favorite TV

evangelist, Brother John, the white shepherd of New York's Ebony Baptist Church. Brother John was holding a telethon, beginning the next day. He showed the large hall he'd rented for the assembly of hundreds of storefront pastors and politicians. If Jerry Lewis could hold telethons for muscular dystrophy, he, Brother John, could hold a telethon for Jesus, to bring the brothers together for a renewal of faith and faith offerings.

Brother John then launched into a sermon on how the devil's servants would try to disrupt his telethon. Some would come to the telethon as wolves in sheep's cloth-

ing. "You know who the devils are", shouted Brother John to his TV audience. His meaning, of course, was that some of the pastors and politicians might come but be less than supportive. Brother John was subtly telling them that those who withheld full support would lose his support.

Clarence heard a different message. He imagined infiltrators disrupting the telethon. So when Brother John asked for volunteers to help set up the show and answer the phones, Clarence decided to be a volunteer.

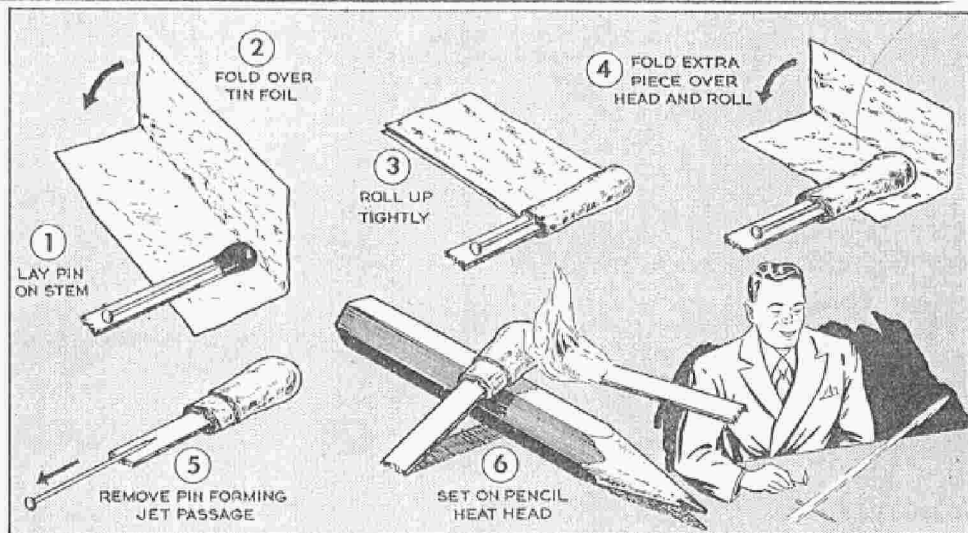

## Match and Tin Foil Make a Miniature Rocket

IT TAKES less than a minute to build and launch a tiny rocket made from a paper match by the method detailed in the numbered drawings above. When an external flame is brought close to the foil-wrapped match head, heat is conducted inside the chamber. Combustion energy set up here

can escape only through the tiny jet passage left by withdrawing the pin. The engine reacts by rocketing off in the opposite direction. Caution: This rocket really travels, so don't try it in a confined space, and make sure that there is no one in the line of fire of the tiny projectile.—ALBERT MEDWIN.

### SOLUTION OF QUARTZ

(Extracting Gold)

*Harper's Weekly, Feb. 21, 1857*

Australian papers report the discovery of a process by which quartz, or silica, is chemically dissolved, and all the gold, metallic oxides, and metals contained in it precipitated. The method is as follows: One part of quartz, in small pieces, is, together with 2-1/2 or 3 parts of carbonate of soda, brought to a red heat and melted. Silicate of soda is now formed, deliquescent in air, and perfectly soluble in cold water. The carbonic acid of the soda being, of

course, given off by the reaction. This silicate of soda is dissolved in water, in wooden vessels, and thus left for a few hours, during which time the gold and all other foreign substances contained in the quartz are precipitated. After the precipitate has been formed, the solution of silicate of soda is, by means of a siphon, decanted into another wooden vessel, in which, by the inflation of carbonic acid, the soda is separated from the silicic acid, and regained as carbonate of soda. This is done by employing the well-known centrifugal air-pump; and, in all particulars, the method of Melsens in the decomposing of saccharate of lime is followed

up. By inflating carbonic acid into the solution of silicate of soda, the silicic acid is separated from the soda. This latter remains in water, the silicic acid has been precipitated in the form of a transparent, nebulous, jelly-like substance, which can not be separated from water by filtration. The solution of carbonate of soda is now decanted, and this, by means of evaporation, is again obtained as dry as carbonate of soda. As such, it can be made use of in further operations.

## MARTIAN'S AND GOD

By Kurt Saxon

Brother John's announcement of his telethon greatly excited Clarence. Clarence liked Brother John. The white shepherd of Harlem's Ebony Baptist Church looked and sounded like Pastor Fain, his spiritual mentor at the hospital.

Clarence and his guides agreed that Martians would try to sabotage the telethon. Helping would not only be a blow to the Martians but a good thing for Pastor Fain, who might really be Brother John.

While discussing with his guides how to foil any Martian attempt to sabotage the telethon, Clarence was reminded of Pastor Fain's young elder. James Blake had been chosen as elder and had been found wanting. He seemed of good character, had been a mainstay of the church since bringing his wife and two children from Iowa three years before.

But Pastor Fain had to be sure, especially since young Blake would handle the contributions. Following Mark 16:18 as the sign of a believer, "They shall take up serpents; and if they drink any deadly thing, it shall not hurt them;....", a test was decided on.

Pastor Fain had put three ounces of ethylene glycol (anti-freeze) in a tall glass of strong, iced grape Kool-Aid. Out on the porch on that warm afternoon he touched glasses with young Blake to toast his eldership. Blake followed Pastor Fain's example and drained the glass.

After a few minutes, Blake began to act intoxicated. Then he babbled about church business, repeating himself and forgetting things. Then he collapsed and a few hours later he died.

Pastor Fain was a man of deep and abiding faith. He showed no remorse and maintained the righteousness of his act. He was a model patient and ministered to the spiritual needs of the other patients. The only time he was a problem was when occasionally a patient would pass on. Then

Pastor Fain would try to raise the dead, and failing, would have to be taken to the quiet room.

Clarence discussed Pastor Fain with his guides. He was advised to contribute the punch. This would not only be for the refreshment of Brother John and his genuine supporters, but would cause the destruction of any Martian wolves in the fold. Clarence was pleased at the idea of one act accomplishing both happiness and doom.

The next morning he went out and bought three gallons of Mountain Dew in several bottles. It had the same general color as anti-freeze but tasted like urine so Clarence poured it down the sink. He went back out and bought three gallons of anti-freeze and filled the Mountain Dew bottles with it.

Then he went to a liquor store and bought four fifths of Jack Daniels and five bottles of Ripple. Next he went to a department store and bought a huge five-gallon plastic punch bowl, a ladle and a hundred paper cups.

Loaded down, he struggled onto a bus and got off near Brother John's Ebony Baptist Church and TV station. When he got there he was met at the door by Brother John's deacon, who challenged him.

"What are you doing here and what have you got?"

"This is refreshment for the telethon", said Clarence.

"We didn't order any refreshments", said the deacon, suspiciously.

"These are from one of Brother John's supporters", said Clarence. "He'd be very upset if his contribution was refused. He told me some Ripple and Jack Daniels in the punch would loosen the wallets of Brother John's guests and make them more at ease before the TV cameras".

The deacon was still suspicious but he



seemed to like the idea, or maybe he looked forward to drinking his fill. He helped Clarence with the load and they set up a table near the entrance.

Clarence looked around and was glad that there were no children present. Even though he realized that children could not be harmed by the poison of unbelief, he feared they might drink too much so there would not be enough to go around. Brother John did not want children underfoot anyway, so that was not a problem.

Clarence watched as the cameramen practiced focusing and checked the lighting. Brother John took some time rehearsing his sermon, perfecting his broad gestures. He worked at bringing his voice several octaves below normal so he could sound like a voice from the Mountain.

The choir did not need to rehearse since most of them were from rock bands. Clarence peeked around a corner and saw several of the choir using hypodermic needles in their arms and even legs. He was surprised that so many in a Gospel choir should be diabetics.

After assuring himself that the punch bowl was ready and seeing several of the politicians and storefront preachers drinking from it, he left. He wanted to rush home and watch the telethon on TV.

By the time he turned on his little set, the choir was well-oiled and swinging. But not to the rhythm of the orchestra. The camera crew was professional so had not tried the punch. Also, the head cameraman did a lot of freelance work for network news agencies. He saw a market for such footage with the tabloid news shows so hoped these lunatics would act up as he expected. He would film it all.

The choir gyrated only to music each member heard. Some sang Gospel and some sang rock, a caterwauling unnoticed by those who had sampled the punch.

Those who had not drunk, looked on, puzzled but believing there was a purpose

behind it all. Brother John had been known to encourage freedom of expression in order to make a point in a sermon.

A young lady in the choir slowly stripped off her robe, then took it all off while singing, "We Shall Overcome". Another female gave a wild shriek and yelled, "They's a nailin' me up in a box and I'm a comin' out!". Then she gave another shriek and leaped onto the stage, falling and flopping about as some of the choir began to clap in unison.

The studio audience broke into applause, then clapped along with the choir. Ratings around the state grew by the minute as viewers called around for friends to watch. Brother John's telethon was going to be a hit.

The orchestra gradually shifted from Gospel to hard rock as those playing the slower music became more frenzied. A guitarist became so caught up he began bashing the other players, finally breaking his instrument across the back of the saxophonist.

Brother John had been too busy to drink as soon as the choir and the orchestra. He did imbibe quite a bracer and its effect had just grown to the point where he felt more aware. He knew something was wrong.

When he stepped before the cameras, he drew himself up and glowered. His regular congregation bent forward expectantly. They knew his angry face promised another real tongue-lashing at old Satan.

"I told you", he said. "I told you and I was right, as the Lord warned me. I told you the devil would send his darkest angels to ruin my telethon. It might be some in this very room who paid these poor, misled sinners to act up. But the Lord will strike them down! You hear me, Lord?"

Clarence nodded in agreement as the cameras panned to one of the politicians in the audience lying twitching his last in the aisle. Two store-front preachers, who had also drunk their fill before being seated, were obviously dead.

Brother John went on, "When a man tries to do right and tries to raise his little



brothers up from the abyss, the devil tries to drag them back. You're seeing it. Watch it! Watch it! Praise God!

"Like so many of my little brothers out there. I was raised at the edge of the abyss. But I had a mother who'd do anything so as to raise her son right. Yes, my mother would do anything. Yes, she was in burlesque."

His words were beginning to slur and he sounded confused as he held tight to the microphone to keep from falling as his voice rose, "Yes, my mother was in burlesque, for me. I remember. I remember as a child watching her on that stage while those evil men lusted after her. She would prance out on that stage wearing nothing but two stars and a cork.

"Those evil men. Yes, they did lust after her. But she did it for me and she had Jesus in her heart!"

He rambled on awhile, uttering similar nonsense. Then he slumped to the floor. The head cameraman zeroed in and Brother John's deacon drunkenly ordered him to turn the cameras off. When the cameraman refused, the deacon drew a pistol and shot the cameraman in the face and then shot himself.

The second cameraman, having been ordered to catch any action, had turned his camera on the deacon when he began yelling. After the shooting, he feared someone else would shoot him so he fled the studio.

Clarence was shocked. He could not understand how Brother John could have preached without believing. And the others? Could they have been Martians? Could Brother John have been a Martian?

Then the Martians were infiltrating the churches. He would check the notices for church get-togethers. He would need disguises. He stayed up most of the night consulting with his guides between news broadcasts telling of the horror.

The TV announcer told him over forty people had died and several were critical. The punch had been poisoned and a young

white male was suspect. Only a few had noticed him but they gave the police artist his description. Clarence marveled at the drawing. Even so, Clarence looked like ever so many young men. He had a forgettable face.

However, his psychiatrist knew that face well. Could that really be Clarence? Now fully recovered from his stroke, the good doctor next day contacted SSI and got Clarence's present address and the phone number of the building's manager.

Late that afternoon he called and persuaded the grudging manager to knock on Clarence's door and have him come to the phone. Clarence wondered at the request since he had never gotten a phone call. He went downstairs with the manager and picked up the phone.

When he said "hello", he immediately recognized his doctor's voice and was half-glad and half apprehensive. After a few pleasantries, the doctor said, "I want you to come back here. You're in danger."

"I live on danger, doctor", said Clarence. "Danger is my bread and meat". He could not remember the movie character he was quoting but he knew it fit. He was becoming addicted to the chase and the excitement. Might it not get the better of him and cause him to become lax, as he did when he let himself be seen by Brother John's people?

"Clarence", said the doctor, "you could use a little R and R. Come on back, we miss you."

Clarence thought a moment and it occurred to him that he should lie low for a while. "Well", he said, "I guess I could come back for a visit". Then he stopped. "No, doctor, I can't. I have a cat and pets aren't allowed".

"Clarence", said the doctor, "we'll make an exception. Forget the rules. Bring the cat. Bring the damned cat, only get back here".

That evening Clarence gathered up all his weapons and paraphernalia and threw



# SUPER Ju Jitsu

**A Benj. Franklin Home-Study Course**

76 Lessons



Copyright 1942

**NELSON-HALL COMPANY**

Publishers

CHICAGO

## Master Course In Super Ju Jitsu

### Contents and Order of Lessons

- Lesson No.
- 1 How to Throw a Man Twice Your Own Weight
  - 2 The Secret of Breaking a Fall
  - 3 Knock-out Spots on the Human Body
  - 4 How to Subdue Two or More Assailants at Once
  - 5 A Sure-fire Knock-out Blow
  - 6 How to Break a Gunman's Wrist
  - 7 How to Throw and Disarm a Hold-up Man Using a Wrist Hold
  - 8 How to Throw and Disarm a Hold-up Man Using a Shoulder Dislocation
  - 9 How to Overpower a Hold-up Man Who Has a Gun in His Pocket or on His Hip
  - 10 Defeating a Gunman Who Has a Gun at Your Back
  - 11 Overcoming an Assailant Who Has a Knife at Your Throat or a Strangle Grip on Your Throat with One or Two Hands
  - 12 How to Ward Off the Attack of a Criminal with a Knife, Club or Brass Knuckles
  - 13 How Any Girl Can Stop a Fresh Guy
  - 14 How to Capture an Attacker Trying to Gouge or Strangle You from Behind
  - 15 Getting the Best of Your Attacker after You are Knocked Down
  - 16 How to Save Yourself and Capture an Assailant Who Seizes You by the Coat Lapels
  - 17 How You Can Floor a Man with Only One Movement
  - 18 The Never-Fail Solid Pleus Blow
  - 19 Breaking Front Grip by Nose-Throat Blow
  - 20 How to Use "The Terror" Winding Throw
  - 21 Neck-Pressure Method of Breaking Front or Back Grip
  - 22 The Super Flying Dive Attack
  - 23 A Powerful Armhold Without Handruffs
  - 24 How to Become Master of the Situation when You are Grabbed and Held by Both Your Wrists

- 25 Quick, Easy Way to Disarm a Gunman
- 26 Head Over Heels and He's Out
- 27 Overpowering an Attacker Who Gets You Down and Attempts to Strangle You
- 28 Holding Down a Very Strong Man by Nerve Pressure
- 29 The 100% Effective Leg Strangulation Hold for Use on Powerful Men
- 30 Vine-like Ground Leg Hold
- 31 How to Throw any Man with an Easy Hand Twist
- 32 How a Girl can Capture a Fierce Snatcher
- 33 Winning by Winding
- 34 "Koban"—Restoring Consciousness to an Unconscious Person
- 35 The Escape-Proof "Come Along" Hold
- 36 Disarming the Hold-up Man
- 37 Flying Tackle with Double Leg Lock
- 38 Quick Arm Hold and Throw
- 39 The Devil's Handshake or How to Act on Friendly Terms with an Enemy
- 40 Special Superior Leg Lock No. 1
- 41 Special Superior Leg Lock No. 2
- 42 The Super Powerful Armhold
- 43 Flying Scissors Double Leg Throw
- 44 Outlaw's Crucifixion
- 45 Combination Leg-Arm Ground Lock
- 46 Slip-Proof, Powerful Arm Lock
- 47 Defending Yourself Against Flying Fists
- 48 Ju Jitsu vs. Boxing
- 49 A Powerful Walking Hold from Which a Criminal Cannot Break Away
- 50 Your Sure Defense Against a Full Nelson Hold
- 51 Speedy Combined Arm and Leg Throw
- 52 How to Stand Your Attacker on His Head
- 53 Pinning Your Assailant to the Ground
- 54 How to Throw an Assailant 5 to 10 Feet
- 55 What to Do when You are Held by Both Wrists
- 56 Your Head in Chancery—How to Break Out
- 57 How to Handle a Running Attack, Armed or Unarmed
- 58 How to Catch a Strangler
- 59 Handling a Strangler Who Attacks You from Behind
- 60 The Famous Double Duty Powerful Leg Lock
- 61 Favorite Ju Jitsu Tricks
- 62 How to Develop Your Arms and Improve Your Hand Grips
- 63 Developing Tough Leg Muscles Through Special Resistance Exercises
- 64 Capturing a Dangerous Criminal Unawares
- 65 Breaking Throat Grip and Capturing Strangler
- 66 How to Disarm a Gunman at Close Quarters
- 67 Breaking Arm-Finion Hold From Front
- 68 Bear Arm-Finion Hold Release
- 69 Single Hand Belt Grip
- 70 Two Hand Belt Hold
- 71 Breaking Grip From Behind
- 72 How to Capture Two or More Assailants who are Attacking You
- 73 Special Arm Twist and Wrist Lock
- 74 The "Come Along" Hold for Policemen
- 75 Quickest Way of Making Your Attacker Absolutely Powerless

*The habit of confidence is attained by practice in overcoming difficulties.*  
—Milton Wright

## INTRODUCTION

It was not until the beginning of the 20th Century—comparatively only a few years ago—that America and Europe learned of the Orient's ancient art of self-defense.

At first it was looked upon with horror because the white man, not knowing how to use Ju Jitsu, could picture himself only as the victim of this most cruel form of attack.

But gradually as the details of Ju Jitsu were learned law-enforcement officials and others in authority saw that they, too, could take advantage of Ju Jitsu's effectiveness. In fact, they learned the art so well that they soon were able to make some improvements.

To this more efficient form of Ju Jitsu we have given the name Super Ju Jitsu. This development could come only as knowledge of Anatomy and Physiology increased.

\* \* \*

Ju Jitsu is a weaponless method of personal combat. The assailant may be armed—and usually he is—but the man using Ju Jitsu as a defense and counter-attack does not use weapons.

A more accurate definition is this: "An application of anatomical knowledge to the purpose of offense and defense. It differs from wrestling in that it does not depend upon muscular strength. It differs from other forms of attack in that it uses no weapon.

Its feat consists in clutching or striking such part of an enemy's body as will make him numb and incapable of resistance. Its object is not to kill but to incapacitate one for action for the time being." (Inazo Nitobe: Bushido, The Soul of Japan).

Lafcadio Hearn, who spent so much of his active life in the Orient, writes in "Out of the East":—"In Ju Jitsu there is a sort of counter for every twist, wrench, pull, push or bend: only the Ju Jitsu expert does not oppose such movements. No; he yields to them. But he does much more than that. He aids them with a wicked sleight that causes the assailant to put out his own shoulder, to fracture his own arm, or, in a desperate case, even to break his own neck or back."

\* \* \*

The many benefits of becoming a Ju Jitsu expert are easy to see. But perhaps for most people who live average lives in average law-abiding communities the greatest benefit is psychological. It is a real, concrete physical benefit, to be sure,—it only starts in the mind.

Explain it this way. You may seldom have occasion to actually use Ju Jitsu on an attacker. But simply the assurance that you are well-equipped to handle any emergency will put a spring in your step.

There is something likable about a man who radiates confidence. And you will be confident, you will be courageous and walk with your chest out when you know you are the master of brute strength.

You will have a different attitude. Your friends will sense some hidden power in you without quite knowing what. This fearless outlook on life is the stuff of which leaders are made.

### How To Study This Course

Whether you read this section or not you will find the following lessons easy to learn . . . they are really self-study lessons.

But by reading this before you start you might even add to the enjoyment in store for you.

\* \* \*

The science or art of Ju Jitsu is built on a sound understanding of complicated subjects such as anatomy, physiology, neurology, etc.

Happy to say, though, you do not have to go into these subjects at all. You can use this knowledge the same as you can use electricity. In neither case is it necessary to go into the fundamentals and dry-as-dust theories.

But if you want to benefit from this distilled knowledge you must follow instructions to the letter. Because the movements look simple do not make the mistake of thinking they may be done in any slipshod way.

Striking a light blow on a certain nerve will disable a man temporarily. The same blow struck elsewhere would hardly be felt. In the same way, a correct side step away from an attacker lunging at you may cause him to dislocate a joint. But if your side step is only "almost right" you may end up with the dislocated joint.

\* \* \*

Throughout this course the words "assailant," "attacker," "criminal," etc., are used to denote the man who attacks you. This is done because Ju Jitsu is used chiefly as a method of defense from surprize attack. In America Ju Jitsu is not a sport—rather, it is a serious business. You use it to defend your life, protect your loved ones and save your property.

Seldom is it necessary to use Ju Jitsu in its drastic forms. After you subdue your man there is usually no reason for carrying your hold further to the point where bones are broken or displaced.

And remember: half-way learning is more than useless in Ju Jitsu. Either you know exactly what to do and do it in a flash—or you fumble around and get licked. Ju Jitsu is never partially successful. It simply does the job or it does not do the job. Take your time and learn thoroughly. The few hours you spend could turn out to be a turning point in your life.

But you'll understand all this as soon as you start the lessons. They are written in a way that gets you into the spirit of the thing right off.

\* \* \*

One last word. Ju Jitsu is translated "to conquer by yielding."

*Opportunity knocks every day but you've got to be ready when you open the door.—Channing Pollock*

### Interesting Note On The Illustrations In This Course

The plain line drawings illustrating the following lessons were tested and found to be easier to understand than other more elaborate forms of illustration.

This entire series of lessons was previously illustrated with photographs of live models. But the pictures, while pretty, did not get the story across.

"Arty" illustrative matter was then tried but the fancy backgrounds, shades and shadows, and other trimmings simply confused the student trying to learn Ju Jitsu.

So, finally, it was discovered that the simplest type of drawing told the story best. And, as this is a course of instruction, not an art gallery, the clearer type of illustration, which you find throughout these lessons, was selected.

## Interesting Background Facts About The Science of Ju Jitsu

The origin of Ju Jitsu is not definitely known. Most historians, however, agree that it was used in the Orient at least 2,000 years ago.

It is thought that this ancient science of defense was invented by the Chinese before the dawn of history. Then it was taken over by the Japanese and developed further.

So effective was Ju Jitsu even at that early date that its use was restricted to Samurai. Under the feudal system Samurai were members of the soldier class constituting the lower nobility.

By their use of this powerful attack and defense method the noblemen could handle several men at the same time and thus convince the common people that the nobility was really a superior breed of humans.

The secrets of Ju Jitsu were jealously guarded for centuries. After the feudal system started to break down, however, more and more Japanese learned the art until the knowledge became general.

Then it became a national sport as well as defense system. It was taught in schools throughout the country. Even women and girls were taught the technique.

Today nearly every Japanese knows at least the elementary techniques of Ju Jitsu. The athletes and members of army, navy and police are experts.

*Go ahead and do it—it's easier to succeed than to explain why you didn't. Success, when you achieve it, is so easy that you wonder how anybody can fail.—William Moulton Marston*

The bigger your assailant, the harder he falls. It is merely a case of your speed and your skill in guiding the assailant over your hip as shown in Plate 1.

Understand this lesson thoroughly then practice with a friend. In a short time people will start noticing that you have a lot more confidence in yourself. And you really will have a different attitude, knowing you can defend yourself against anyone, regardless of his size.

Here is how you do it:

First face your friend, then seize hold of his right wrist with your left hand. At the same time step behind him with your right foot so that your buttock comes exactly in the rear of his.

Your feet are now about 24 inches apart. Next bend downward to your left front, bring the trunk of your body downward in a horizontal position. You need nothing else but this combined movement to lift your opponent off his feet and into the position shown in Plate 1.

Just try these movements over a few times and you will be surprised at the ease with which your opponent comes off the ground. It is a fact that you hardly know you are doing it! It should be emphasized that your knees must be kept straight, never bent.

Combine all the above movements so you can do one after another, quick as a flash, without thinking them out. When your man is off his feet, don't move your feet at all, but swing your trunk to the left—and release your hold. Your man will go sprawling on his back, giving you time for further action.

Here is the secret of the whole movement: Once you step behind your man to throw him **DON'T MOVE YOUR FEET.**

*It is impossible to read properly without using all one's engine-power. If we are not tired after reading, common sense is not in us.—Arnold Bennett*

## How to Throw A Man Twice Your Own Weight

### LESSON ONE



Plate 1

**CORRECT BALANCE** is the most important fundamental in Ju Jitsu. Plate 1 illustrates a 100-lb. girl throwing a man weighing 200 lbs. This does not take muscle—it takes technique.

Regardless of your weight you can easily balance a 200-lb. man on your buttock (seat). If you do it right you will hardly realize he is resting on you. **Balance conquers weight.** Remember this. It is important.

## The Secret of Breaking a Fall

### LESSON TWO

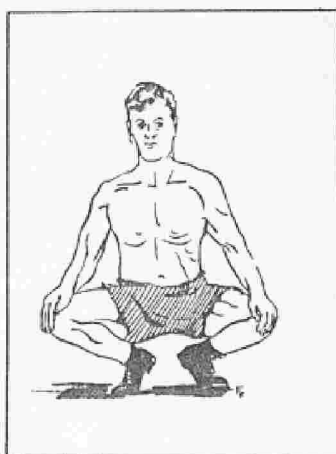

Plate 2

Fall breaking is an art in itself.

This knowledge is most important for wrestlers and Ju Jitsu experts. But it is just as important to you in your everyday life as it may save you a broken leg.

The average person who has had the misfortune to slip and lose his footing on a slippery pavement falls in a most dangerous position. He puts his hand out behind him, trying to save himself.

from injury, and thereby allows the whole weight of his body to fall on the shoulder which is easily dislocated. Or he falls on his seat and risks internal injuries.

Putting an arm out to the rear to avoid injury simply makes injury more certain. Your arms should come out to the front.

When you fall or are thrown, always keep your whole body relaxed. You will then fall as lightly as possible. On the other hand, if you stiffen up your body in falling you hit the ground with dead weight and your tight muscles are apt to snap.

A relaxed and loose body usually saves a drunken person from serious injury when he falls.

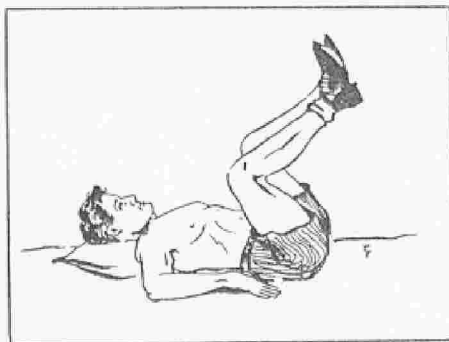

Plate 3

This is the secret of falling without getting hurt: When you go over backward keep your body relaxed and your chin on your chest to prevent striking your head on the ground. Your arms should come out to your front, bent at the elbows so that your arms represent the letter L. Fingers should be loosely extended but close together.

As you come to the ground strike it with the palms of your hands, then with your forearms at practically the same time. Your chin, you remember, is forward resting on your chest. Bring your legs up bent at the knees and well apart. Practice this fall step by step so you will do it the right way automatically when you really do fall unintentionally.

Practice fall breaking on an old mattress. Squat as illustrated in Plate 2. This is sitting position with your hands resting on your knees, which should be well apart.

Now roll backward. In doing so keep your body relaxed and chin forward, resting on your chest. As you are going backward you automatically take your hands from your knees and quickly strike the ground with the palms of your hands, allowing your legs to come up as shown in the position in Plate 3.

Repeat these movements a few times and you will soon master the art of breaking a fall. You will find it an excellent exercise for keeping your body in trim, too.

*Chop your own wood and it will warm you twice.—Proverb*

## "Knock-Out" Spots on the Human Body

### LESSON THREE

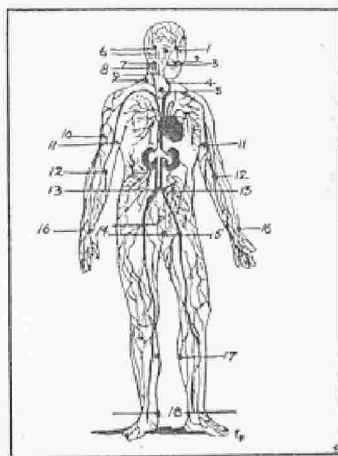

Plate 4

The human body is wonderfully constructed with its many distinct bones and separate nerve centers. There are more than 200 bones in the body. Most of them can be broken or dislocated from a joint if pressure is applied in a certain way and at a particular spot. And there are nerve centers on which a blow will mean death or at least unconsciousness.

Pressure on some nerve centers means partial paralysis and insensibility. Pressure on other nerve centers brings a stimulation that arouses an unconscious person. There are other ultra sensitive parts of the body besides bones and nerve centers. These will be located for you in this lesson and illustrated in Plate 4.

Before identifying these vulnerable points of the human body a word of caution is necessary. In practicing with a friend apply only the very lightest pressure. You might do serious harm using what you believe is "moderate" force. Use common sense. When you meet an assailant and you are facing life or death—then you can go "all out."

1. **TOP OF NOSE.** Clench your fist, allowing the big knuckle of your middle finger to stick out slightly forward. Then deliver a blow directly on the spot numbered #1 in Plate 4, making sure you strike with your middle knuckle. Try this on yourself lightly. A stiff blow results in a knock-out.
2. **POINT OF NOSE.** This spot struck in the same way will also bring insensibility.
3. **MIDDLE OF UPPER LIP.** That little hollow under the nose. A sharp blow on this spot with the middle knuckle will also drop the assailant unconscious. Stand before a mirror and try this punch on yourself—but very lightly.
4. **THROAT.** You will have no trouble dropping an attacker with this blow. Extend the fingers of the right hand and strike with the edge of the hand, the fleshy part just below the little finger. If the assailant is hit on the Adam's Apple he will certainly go down. And if he is hit hard enough his larynx will be ruptured.
5. **STERNUM.** The sternum is that little hollow at the throat situated in the middle of the breast bone at the top. If you



are having a rough and tumble with an assailant on the ground place the end of your thumb in his sternum and press downward. He will have to give up. Continued pressure at this point will choke a man so you have the strongest of men at your mercy when you apply this pressure.

6. **BASE OF SKULL.** Deliver the blow with your hand's edge as under point 4 above. It is a knock-out blow.
7. **LOBE OF EAR.** If your assailant is on the ground place the heel of your left hand on his chin and turn his face away from you. At the same time place the thumb of your right hand close up in that little hollow behind the lobe of his left ear and press downward. That will end his battle. If he is standing place both thumbs one under each ear and press inward. This will make him release his grip double-quick, should he have hold of you.
8. **BACK OF NECK.** A blow delivered with the hand's edge on the nerve center at the back of the neck will drop your assailant like a cord of wood. There is record of a man receiving this blow and going blind as a result of the severing of the optic nerve.
9. **CAROTID ARTERY.** If you grip a man's throat tightly with both hands you will choke him by stopping his breath. But if you strike a blow with your hand's edge across the carotid artery (which is situated on each side of the neck) you will stop the flow of blood to the brain and cause immediate unconsciousness. Or if you press the carotid arteries between your fingers and your thumbs insensibility will result in just a few seconds.
10. **TRICEP MUSCLE.** Seize an assailant's arm at the wrist with your left hand and extend his arm out straight in line with his shoulder. Then turn the palm of his hand upward and his will bring the tricep muscle of the upper arm in line for a blow. (The tricep muscles are situated on the back side of the upper arm.) Deliver your blow with force and with the fingers of your hand extended. This will numb his arm into a partial paralysis, making it temporarily useless. This blow also brings on a "pins and needles" sensation.
11. **UPPER ARM.** Another sensitive nerve-center is situated in the upper arm, centered just below the big muscle or bicep. You will be able to locate it with just a little practice. Pressure at this point with the thumb will also bring on partial paralysis of the arm, leaving it temporarily useless.
12. **BEND OF ELBOW.** It is best to learn this one thoroughly with a friend before you try to use it. Seize his right wrist with your left hand and lift his arm sideways in line with his shoulder. At the same time raise your right hand and grasp his arm at the elbow joint. Keep your fingers at the back of his elbow and your thumb in the bend of his arm. That is where the nerve center is located. Now turn left about (outward) and turn in the same direction and abreast of your opponent. As you are turning press inward with your thumb and place his and your own left hand up and under his armpit. And place his elbow joint under your own left armpit.

You now have him in a most effective wrist lock. A little pressure with your left hand can easily break his wrist.

(This is a favorite hold of police officers). Another result of this hold is that you can bring about a partial paralysis by exerting a steady pressure with your thumb on the nerve center at his elbow joint.

13. **SOLAR PLEXUS.** Extend the fingers of your right hand and bunch them in together. With your hand in this position deliver a blow with force in the Solar Plexus. ("Solar" means sun or the central part—the stomach—and "plexus" refers to an important junction of nerve centers, blood vessels, etc.). Twist your hand, in making this blow, so that you finish the blow with the palm of your hand upward. This will instantly drop your assailant and cause temporary partial paralysis of the stomach muscles.
14. **SCROTUM.** The scrotum, situated in the fork of the legs, is a man's weakest point. A blow delivered here with either the knee or foot will drop the burliest assailant in agony. It is not very nice to put into operation. But from the self-defense point of view you are fully justified. It may be the means of saving your life.
15. **GROIN.** This spot is the crease where the thigh joins the abdomen. Knowledge of the nerve center here is invaluable to wrestlers. It is the best way of breaking a Neck Scissors Strangle hold. A quick location of this vulnerable point with thumb pressure will make your opponent instantly release his leg grip from your throat.
16. **HEEL OF THUMB.** Extend the fingers and thumb—then stretch the thumb away from the fingers as far as you can conveniently. In the little hollow you see at the heel of your thumb there is another nerve center about which it is valuable to know. You can find this spot quickly by shaking hands and allowing your thumb to go down to this point. Continued pressure on this spot with your thumb will result in partial paralysis of your opponent's hand.
17. **CALF OF LEG.** Pressure at this point with the thumb will cause partial paralysis of the leg. You can get this same result by striking with the hand's edge.
18. **ANKLE JOINT.** At the back of your ankle joint there is a little hollow on each side. Apply pressure here using the thumb on one side and the middle finger on the other. This combined pressure will leave the foot partially paralyzed temporarily.
19. **SPINAL COLUMN.** The roots of many nerve centers are located along the backbone. Pressure applied to some of these centers is stimulating and may revive an unconscious person. You will learn more about this in the lesson on "Katsu." Pressure applied on certain other nerve centers cause intense pain and brings about unconsciousness.

Here is one way that wrestlers work on the spine. Extend the fingers, keep them close together and rub the tips up and down briskly along the full length of the backbone. This may also be done with the knuckles of your clenched fist.

A blow delivered with the heel of your hand just above the seat at the bottom of the spinal column is extremely effective. The vulnerable spot is the third from the last vertebrae called the Lumbar Vertebrae.

## How to Subdue Two Or More Assailants At Once

### LESSON 4



Plate 5

If you should be attacked by two or more men at the same time you have every right to defend yourself using the most effective methods you know. In other words, anything goes.

Thoroughly learn and understand the blows and holds taught in these lessons. Then when an emergency does arise you can act with lightning speed. At least half your success in combat is the result of acting instantly without hesitation. The other half of your success may be attributed to your sound knowledge of Ju Jitsu. Strength alone has very little to do with it.

Now then, when set upon by several toughs proceed as follows:

With your hand's edge apply the knock-out blow described in lesson 5. This will drop the first assailant. Follow-up quickly with the "Flying Dive" on assailant No. 2. This dive is described in lesson 47. These two methods are undoubtedly the quickest ways of putting them out of action. Additional assailants can be adequately handled by giving them the hand's edge knock-out the first man got. Take care of each member with speed and shift your attention from one to the next so rapidly that you have them all before any one realizes you are using anything more than just an ordinary punch.

Or you may quiet assailant No. 3 by using the information you have on the middle upper lip, explained in the last lesson, part 3.

Clench your fist and deliver this blow with the knuckle of your middle finger—or with all your knuckles. You can't miss.

The next thing to try on your pack of assailants (if one of them is still standing) is the most ruthless of all. Bring up your knee with a snap and catch the ruffian between the legs, striking his scrotum. The only thing he can do is drop to the ground in agony and absolutely helpless. After a considerable time when he is able to get up he will be in no mood to continue his attack on you.

The solar plexus blow described in the last lesson under point 13 is also one you should be ready to use when the opportunity presents itself. With a clenched fist deliver your blow with an upward movement, palm to remain upward. More about this in lesson 18. For now just remember that this blow is easily landed and will quickly disable your assailant.

Use these several different blows in quick succession to keep

the attackers baffled. You might use all four, one after another, on the first four men then start all over again on the rest of the gang.

If they are armed and your life is in danger—or for any other urgent reason you need to use more severe methods—use instruction in lesson 9. With speed and force you will disarm the man and dislocate his shoulder.

After this, for speed the next best move is "Two Handed Twist and Throw" as taught in lesson 7. As your murderous gunman hits the ground you can instantly break his wrist by forcing your thumbs inward toward your fingers and at the same time twist the hand outward. This will snap the wrist like a match stick.

If this sounds gruesome remember that stopping a couple of lead slugs with your body is even more gruesome.

Vulnerable Point No. 3 (previous lesson) is so important that the balance of this lesson will go into it in more detail.

The exact spot is marked "X" in plate 5.

This upper lip nerve center is one of the most sensitive points in the human body. A brisk blow on this spot will drop even the strongest ruffian, leaving him senseless for a time.

The width of the average person's clenched fist is 3½". So an ordinary punch full on the mouth may leave messy results but little serious damage because the best part of the blow lands on the chin where it does very little good. This punch might loosen a few teeth and make the lips bleed and swell.

You get very definite results, however, when your middle knuckle hits the sensitive spot on the middle upper lip. Because your knuckle sticks out beyond the rest of the fist it strikes with a more sudden impact when it is aimed at the proper spot. The chin or the nose does not slow down the crash of knuckle and lip.

Again it might be well to advise you to stand before a mirror and give this blow to yourself lightly. Then you will realize what you are doing.

You may deliver this blow in different ways depending upon the necessity of the moment. If an assailant is trying to strangle you he is open for this blow.

A girl seized around the waist, from the front, for instance, almost certainly is not strong enough to push her attacker away. But she can quickly cool his ardor by giving him a smart blow in the middle of the upper lip with her middle knuckle.

Strike one assailant with the clenched fist but where there are more than one it is best to strike with the hand's edge. Then your hand will be already open should you have to throw the other assailants.

In this instance the fingers will be extended and the hand's edge will strike the assailant with a chopping motion right in the middle of the upper lip. This attack will enable you to drop several toughs one right after the other.

*The recipe for perpetual ignorance is: be satisfied with your opinions and content with your knowledge.—Elbert Hubbard*

*It is lucky for the people who aim high that most people have no aim at all.—Walter B. Pitkin*

## A Sure-Fire Knockout Blow

### LESSON 5

Plate 6

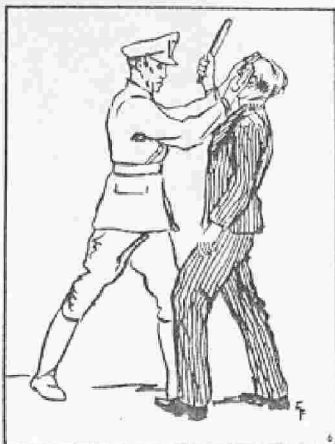

Here is something special for when unarmed and singlehanded you have to deal with two or more assailants. This blow will knock even the burliest rough-neck unconscious.

In plate 6 you see illustrated the exact location this blow should be landed. The spot is midway on the jaw and it should be struck with the hand's edge. As a short quick blow is more effective do not let your hand go back past your shoulder to start the swing. In other words your open hand will travel no more than 6 inches before striking the outlaw's jaw.

You can hit him solidly before he is aware of your plan if you place your left palm on his face and draw it down. This will make him shut his eyes and give you the opportunity you want to use your right hand.

This blow is struck so quickly that it is a good one to use where you are handling several assailants at the same time. Lesson 69 includes more on his subject.

Hand's Edge blows are used so often in Ju Jitsu—the effectiveness of these blows depends so much on the firmness of the hand—it is a good plan to develop and harden this member. Clench your fist and relax it regularly for about 5 minutes twice each day. Then extend the fingers and hit a table or other hard object with the hand's edge. Do this chopping exercise about 100 strokes each day. This will make the flesh firmer and toughen up the skin, too.

## How to Break A Gunman's Wrist

### LESSON 6

Plate 7

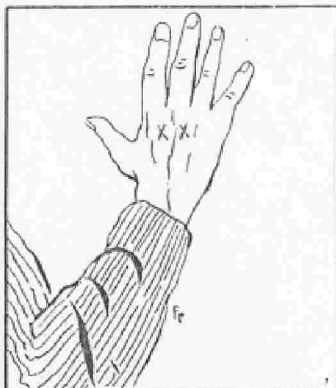

The crosses on the hand in plate #7 locate two vulnerable nerve centers. These are situated one inch below the knuckles on each side of the middle finger.

These super-sensitive spots are easy to locate on your own hand. Try it. They are the points where pressure has to be applied with the thumbs to discern a gunman. In the following lessons these spots are used in throwing a man to the ground.

Pressure at these points forces a man to relax his grip and open his hand. He drops the gun, knife, club, or whatever other weapon he holds.

Place the fingers of both your hands in the palm of your assailant's hand and your two thumbs on the two nerve centers on the back of his hand. Then force your thumbs inward slowly toward your fingers as if you were folding over a sheet of paper. At the same time twist his hand to your left (outward). Even the thickest wrist will snap and break like a pencil.

You understand, of course, that slowly twisting the assailant's wrist this way will force him to the ground and you need not do any more damage in most cases.

## How to Throw And Disarm A Hold-up Man Using a Wrist Hold

### LESSON 7

Plate 8



The secret of handling a hold-up man is speed. You will not have time to think after the gun is aimed at you. So study these lessons carefully and learn now what to do when the situation does arise.

As the thug faces you, gun in hand you instantly use your left hand to push the gun away from you—push it toward your right. This you will do in a flash, leaving the muzzle pointing away to the right of you so the bullet will not hit you even if the gun does go off.

Now at the same time you are pushing the gun with your left hand raise your right hand and catch his gunned-hand tightly between both your palms. In other words you have done two things at once: first, you pointed the gun away from you and, second, you grasped the gunman's hand securely in both of yours. Illustrated in Plate 8.



Plate 9

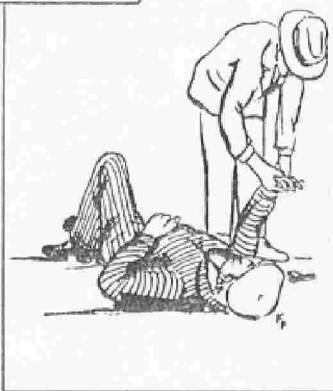

Plate 10

With your tight grip twist his hand inward from the wrist so the muzzle of the gun is pointing toward him. Continue twisting backward to your left and as illustrated in Plate 9 he will head toward the floor.

He will hit the ground hard—hard enough to slow him up and give you time to place your right foot close up against his armpit while still holding his wrist tightly. See Plate 10. With your fingers in the palm of his hand and your two thumbs at the back of his hand apply a firm steady pressure on the two nerve centers described in lesson 6.

You will then disarm your man by forcing your fingers inward toward your thumbs, squeezing tightly, and twisting his hand to the left as shown in Plate 10.

Not only will this compel him to drop his gun but it gives you a grip on him that will break his wrist if applied with force.

In this position he will stay quiet until the police arrive to take charge.

## How to Throw And Disarm A Hold-up Man Using a Shoulder Dislocation

### LESSON 8



Plate 11

This lesson will teach you how you can do the following three things in one lightning-like series of movements: disarm the gunman, dislocate his shoulder, knock him unconscious.

You start again by pushing the gun away from you. This time use your right hand and knock the gunned-hand to your right so you are out of the line of fire. See Plate 11.

At the same time lift his forearms up so that with his bended elbows his arms each make a right angle. Raise your left hand up under his right arm and grasp your own right forearm as your right hand is already holding his right wrist. This is made clear in Plate 12.

When you lift his arm upward in this position you automatically allow your hand to revolve around his wrist so that your right elbow joint is sticking in his face.



Plate 12

*Act as if you were courageous; if you will do this, you will become courageous.—Homer Crog*

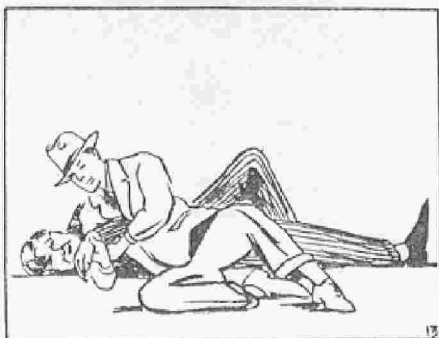

Plate 13

As soon as you get into this grip you change your position by jumping out to your own left front and sitting down. While doing this you simply bear downward with your right hand on the gunman's wrist and upward with your left forearm. This will throw him with such force that in all probability he will be knocked cold when his head hits the ground. You will go down on top of him and your full weight will catch him in the solar plexus taking away his wind temporarily. Of course, his hand will then relax and drop the gun.

If for any reason the outlaw is still not completely under control as he lays on the ground continue as follows. Force his wrist round toward yourself with your right hand—and at the same time with your left forearm force his wrist upward and away from yourself. See Plate 13 for details. This will dislocate his shoulder.

You may find this effective against an unarmed assailant also.

Caution: be very careful in practice. Use no force or pressure.

## How to Overpower a Hold-up Man Who has a Gun in his Pocket or on His Hip

### LESSON 9



Plate 14

From a position as illustrated in Plate 14 you cannot grasp his wrist quicker than he can shoot. So instantly jump to your left to get out of his line of fire. Then seize his right elbow joint on the outside with your right hand. Your left hand will go up

inside his arm gripping his upper arm. This is illustrated in Plate 15.

All this is just one combined movement which, if done with speed, will force his gun upward behind his back and at the same time dislocate his shoulder. Plate 16.

Here is a bit of applied psychology: Gunmen are cowards at heart. They don't expect their victim to show fight. And they are totally unprepared for it when they are resisted. So never hesitate to strike quickly.



Plate 15



Plate 16

Your success in overpowering a stick-up artist is part advance knowledge of what to do in the emergency—this course is teaching you that. The other factor in your success is your split-second timing. You can out-think and out-act a dim-witted thug!

Continued next issue

*It is better to wear out than to rust out.—Bishop Cumberland*

# SUPER Ju Jitsu

Copyright 1942

## Defeating a Gunman who Has a Gun at Your Back

### LESSON 10

Plate 17



When the outlaw pokes his gun in your back and says "Stick 'Em Up!" there is nothing you can do at the moment but follow instructions.

Then from your position as in Plate 17 spin to your left and in doing so get out of his line of fire and knock his gun hand aside with your left arm. Your left hand will go automatically to his wrist. With your right hand seize him around the waist. Step behind him with your right foot, bend downward quickly to your left and lift your man off his feet. This feat of balance is illustrated in Plate 18.

Throw him to the ground and get your right knee in his ribs. Then move his arm across your left leg and your right thumb close up under the lobe of his right ear. Apply pressure in that hollow on the nerve center.

The gunman's position is now escape-proof but if the situation warrants you are prepared to

1. Fracture his ribs by delivering violent blows with your right knee.
2. Render him unconscious by continued pressure with your thumb on his ear lobe nerve center.
3. Break his arm by bearing down with force with your left hand which is at his wrist. Plate 19.

*Always do what you are afraid to do.—Ralph Waldo Emerson*

*He that is master of himself will soon be master of others.—Thomas Fuller*



Plate 18



Plate 19

## Overcoming An Assailant Who has a Knife at Your Throat—or Who is Choking You With One or Two Hands

### LESSON 11

Plate 20



20

Seize the assailant's right wrist which is near your throat (either choking you or holding a knife) with your right hand and



shoot the palm of your left hand up under his right elbow. See Plate 20.

Then, all at the same time, twist your head, his wrist and his elbow joint to your right. Advance your left foot well in front of him and force the trunk of his body downward. You will then be in the position illustrated in Plate 21.

Now bear downward on the knuckles of his hand and force his forearm to your front.

Use the amount of pressure demanded by the situation. The end result is a broken wrist, a dislocated shoulder, and loss of his gun.

This is a variation of the movements described in Lesson 33.



Plate 21

**How to Ward Off the Attack Of a Criminal With a Knife, Club or Brass Knuckles**

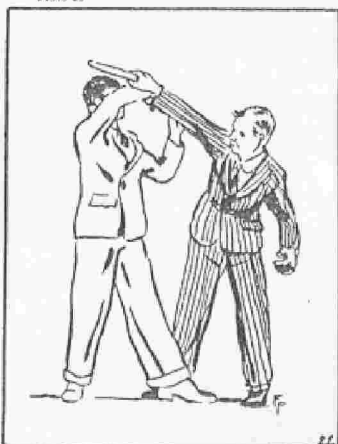

Plate 22

LESSON 12

The best way to avoid a blow ready to land on you is by raising your right forearm to change the course of the blow up over your head.

At the same time your left hand will come up under the killer's elbow joint. Advance your left foot as shown in Plate 22.

Continue the movement as explained in Lesson 11 until you have him in the position shown in Plate 21.

There will be no fight left in him after you start bearing down on his knuckles and forcing his forearm to your front.

**How a Girl Can Stop a Fresh Guy**



Plate 23

LESSON 13

If you are walking along the street and are molested by a man it is easy for you to take care of the situation even though no policemen are around. This masher may put his arm around your waist and say something to you.

To distract his attention from your plan of attack it is best that you answer him—and at the same time grip his right wrist with your right hand as shown in Plate 23. Instantly spin around and seize his upper arm in your left hand. This is made plain in Plate 24.

Continue your twisting movements and advance your left foot in front of him. Pull his forearm close in toward your body and force him downward into the helpless position illustrated in Plate 25.

By further forcing of his forearm straight forward you will dislocate his shoulder and teach him he is no Don Juan.



Plate 24



Plate 25

25

## How to Capture an Attacker Trying to Gag Or Strangle You from Behind



Plate 26

26

### LESSON 14

His arm will come around your head from where he is standing behind you and his hand will go around your throat or over your mouth.

You will quickly grip his wrist with your left hand. With the palm of your right hand get a position under his elbow joint.

Then, with a snap, pull downward with your left hand at his wrist and bear upward with your right hand under his elbow This will loosen his grip around your head enough to enable you to duck your head down, under and out. Plate 26.

As you are getting your head out take his arm along with you and force his forearm up behind his back. He is powerless.

Another way this may be handled after you have his arm well gripped is to get your left foot in front of his right foot and kick his foot from under him. This will cause him to fall forward.

You will then quickly bring up your left knee and kneel on his upper arm making it impossible for him to move. This is illustrated in Plate 27.

He will give up and cry for mercy if while you are kneeling on his upper arm you lift his forearm upward.



Plate 27

27

## Getting the Best of Your Attacker After You are Knocked Down

### LESSON 15



Plate 28

28

While it is agreed that you can work better up on your two feet you may be taken unawares and find yourself on the ground before you realize it. And furthermore, your assailant may be astride you ready to attack with a knife or club.

Before the situation gets more serious seize his ankles, one in each of your hands, and pull yourself close in so your shoulders come over his shoes—and at the same time bring your two legs up outside of his. Cross both your feet in front of him as shown in Plate 28.

Keeping your feet crossed, straighten your legs upward and backward. This will force the man backward, off his feet and flat on his back. As he is falling place both your hands under his legs and grip your own hands together or lock your wrists together with your hands.

Then get his legs wedged tightly under your armpits and lean backward so the weight of your body rests on his feet. You may, if the occasion demands, deliver a solar plexus or stomach blow with both your feet while they are still crossed.

As you see in Plate 29 you now have him in a hopeless condition. He is in no mood to continue the fight.



Plate 25



Plate 26

## How to Save Yourself and Capture an Assailant Who Seizes You by the Coat Lapels

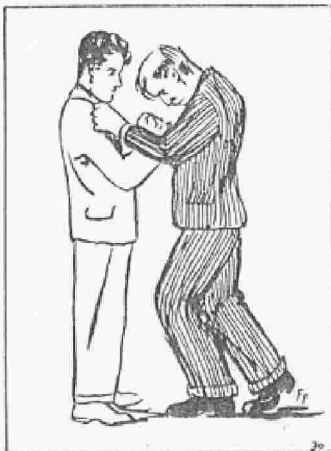

Plate 30

### LESSON 16

This is a good lesson to learn well. First, because it is very effective in foiling your attacker's criminal plan. Second, here is a position in which most people find themselves when they are being attacked.

The assailant grabs you from the front by the coat lapels or the shoulders. His idea is to punch you in the face when he has you in a good position. Or perhaps he plans to butt his head full in your face.

In any case you don't allow him to get very far with either intention. Quickly up with your clenched fists between his arms as shown in Plate 30.

After this good *stiff* pair of blows to his face or chin you continue the upward movement of your arms. Then encircle your right arm over and under his left arm, gripping his clothing with your right hand.

At the same time place your left foot behind his left foot. Then the palm of your left hand under his chin. Now throw your man down on his right side.

Quickly place your right knee on his neck and your left knee in his ribs. Sit upright and lean backward as shown in Plate 31.

You are now in position to break his arm, fracture his ribs, and punish his face with your knee.

## How to Floor A Man with Only One Movement



Plate 32

### LESSON 17

A very quick, effective way to get a man off his feet is illustrated in Plate 32.

Get yourself on his left side and in one speedy movement do these two things:

First, strike him across the throat with the edge of your right hand. Fingers are extended.

Second, kick his left foot from under him with your right foot.

Do these two things at once. It is another trick of balance—this time, his loss of balance.

*It is lucky for the people who aim high that most people have no aim at all.—Walter B. Pitkin*

*Nothing worth while was ever accomplished that did not at first seem impossible*

*The recipe for perpetual ignorance is: be satisfied with your opinions and content with your knowledge.—Elbert Hubbard*

*A true test of the well-managed life is the ability to get things done.—Milton Wright*

*Opportunity knocks every day but you've got to be ready when you open the door.—Channing Pollock*

## The Never-Fail Solar Plexus Blow

### LESSON 18

Plate 33



33

This course has shown you there are always two things to do when you are attacked. First protect yourself from injury.

But after that has been accomplished it is your duty (and pleasure) to slow up the criminal so the officers of the law can get him.

If an assailant is striking you with a swift right punch protect yourself by instantly parrying the blow with your left forearm. At the same time take care of the assailant with your right hand.

Extend all the fingers (but bending the tips in at the knuckles) of this right hand and with the thumb in the middle of the hand and the palm turned downward deliver a blow into the pit of his stomach.

With your fingers still in the same position and as part of the blow twist your hand so you will finish delivering the blow with your palm upward. He will go down limp as your blow temporarily paralyzes the stomach muscles. Plate 33 shows this famous solar plexus blow.

## Breaking Front Grip by Nose-Throat Blow

### LESSON 19

Plate 34

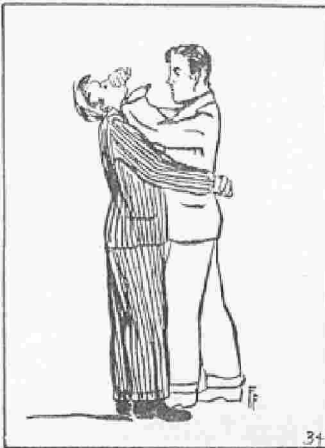

34

Sometimes an attacker will clutch you around the waist from the front and try to pick you up off the ground.

With both your hands free you will, at the same time, deliver a sharp blow under the cartilage of his nose with your right hand's edge and with your left hand's edge you will strike him across the throat.

Plate 34 shows how easily you can do this.

## How to Use "The Terror" Winding Throw

### LESSON 20

Plate 35



35

This is one of the most drastic Ju Jitsu methods of protecting yourself from attack and subduing a dangerous criminal.

He starts his attack while facing you. Don't wait. Seize his right wrist on the outside with your right hand and force his arm backward, upward, forward and downward in a circular movement.

At the same time you will turn right about, winding his arm around your waist as shown in Plate 35.

Without any break in your movement jump straight forward to your front and sit down on the ground. All the while you are keeping his arm tightly around your waist.

In this position you get your results by bearing downward on the knuckles of his hand while you are forcing his forearm to your left. This is illustrated in Plate 36.

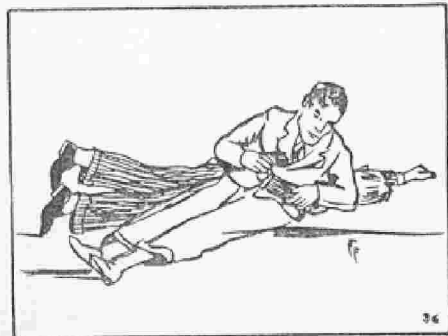

36

Plate 36

If carried out to its limits you would make his face extremely sore, break his wrist and dislocate his shoulder besides, per-

haps, knocking him unconscious.

This hold is what makes it almost impossible for a boxer to defeat a wrestler in a free-for-all.

The boxer will try to get in a powerful right punch right at the beginning of the encounter. The wrestler will parry the blow with his left. And with his right grasp the boxer's right wrist and proceed to disable the fighter as outlined in this lesson.

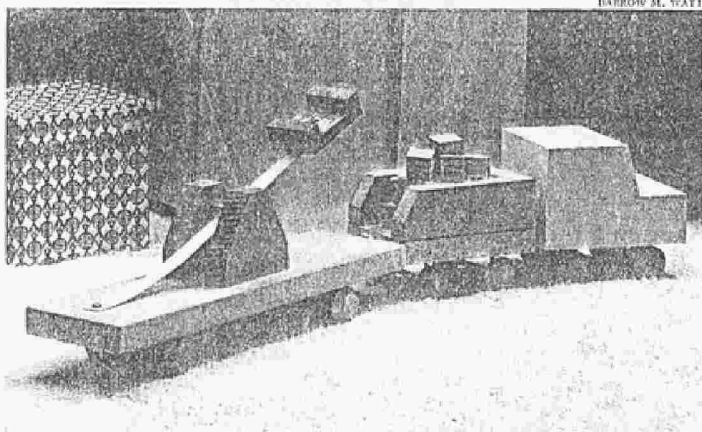

DARROW M. TRATT

Catapult, ammunition carrier, and truck—all held in line by magnetic cabinet latches

## Catapult... for storming a castle

A worn hacksaw blade neatly wrapped in adhesive tape provides the launch power for this toy catapult. Complete with ammunition carrier and tow truck, the toy can be put together in an evening or two by a home craftsman with a power saw.

You'll need a short length of 2 by 4 for the truck; about 3 feet of 1 by 4 to make the two bases, carrier enclosure, and triangular catapult blocks; 2½ feet of 3/16-inch wood doweling; a dozen 1 3/8-inch or longer screw eyes; the hacksaw blade; and a small screw and bolt.

The units roll on wood wheels—knobs, drawer pulls, spoons, or short lengths of 1 3/8-inch dowel drilled to accept the 3/16-inch dowl axles.

For the catapult mechanism, drill holes 3/16 inch apart in two triangular wood blocks and insert short 3/16-inch dowels. Glue the triangles to the base. Bolt a U-shaped piece of scrap wood to one end of the tape-covered hacksaw blade, using the blade's hole; then slide the blade be-

## Soldering Large Sheets of Metal Made Easy by Preheating

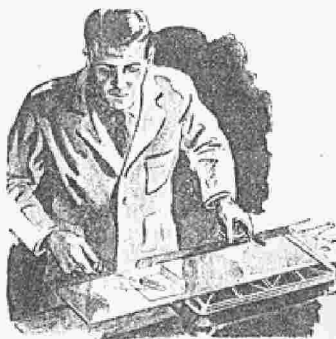

Because a large sheet of metal will dissipate heat quickly from a small soldering iron, it is often difficult to solder large areas. However, by preheating the metal over a burner and maintaining that heat, the job becomes quite simple. It's necessary to determine first the proper temperature for the metal, and also how far the work must be kept from the burner. The over-all temperature of the sheet should be just below the melting point of the solder.

tween the dowels and wood-screw the other end to the base, as pictured. The springy blade provides good propulsion.

To provide easy in-line towing, cut a notch with a power saw or chisel in the back of the truck and ammunition carrier to hold a standard cabinet magnet latch; affix the metal strike plates to the front of carrier and catapult.

Before gluing the second wheel on each axle, slide the axle through screw eyes positioned below each base.

A varnish or enamel finish is optional. Then load up the ammunition carrier with wood chunks, and place all beneath the Christmas tree.

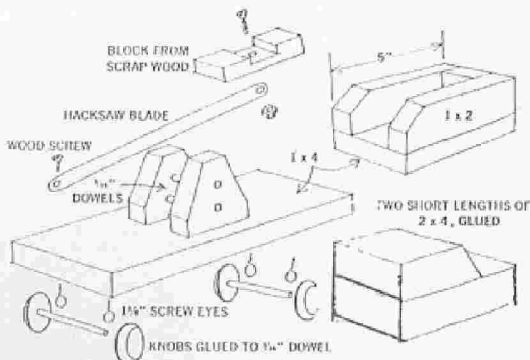

# SUPER Ju Jitsu

Copyright 1942

## Neck-Pressure Method of Breaking Front or Back Grip



Plate 37

37

### LESSON 21

Here is a very useful hold that is effective in breaking an assailant's grip. He may have seized you from the front by your clothing—or he may be holding on a door or rail and refusing to let go. In either case you want to force him to relax his grip.

Grasp his coat collar back of his neck with your fingers only. Allow your two thumbs to come forward and rest on his neck one on each side of his Adam's Apple. See Plate 37.

Now then, your fingers will give you leverage while your thumbs force inward toward each other. The assailant cannot endure this intense pain and will give up.

Your man may be in such a position that you cannot get in front of him. In that case get close to his back and place your left forearm across his throat. At the same time place the edge of your right hand (the finger extended) up under the cartilage of his nose.

Force his head backward and drag him away. It will take but little strength to break his grip.

*This World belongs to the energetic.*—Ralph Waldo Emerson

*The surest hindrance to success is to have too high a standard of refinement in our minds, or too high an opinion of the judgment of the public. He who is determined not to be satisfied with anything short of perfection will never do anything at all either to please himself or others.*—Hacitt

*Most alibis are merely a confession of laziness.*—Fred B. Barton

## The Super Flying Dive Attack

### LESSON 22



Plate 39

39

This lesson teaches you the best method of defense and attack against a man who really knows how to fight. It may be a sportsmanlike encounter between a boxer and a wrestler. Or you may simply be violently set upon by an assailant who knows how to use his fists.

At first keep well away from the man, with your chin resting on your chest to prevent a blow on that spot. Cross your arms in front of your body to ward off a knock-out blow at your solar plexus. But at the same time keep your arms relaxed so you can act in a *flash* when your opportunity comes to attack.

Now with your eyes on the man work your way in gradually. In almost every case a fighter will lead with his left. You are expecting it so you are prepared to avoid the blow with your left forearm. See Plate 39.



Plate 39

39

Instantly you drop down on your own right knee and seize his left ankle with your right hand. This is the movement where the flying dive may, in many cases, be necessary.



With your right hand around his left ankle lower your left hand (from defending yourself against his punch) to his solar plexus. In one combined movement pull toward you with your right hand and push away from you with your left hand. This will send the man sprawling on his back as illustrated in Plate 40.

As he is falling backward you stand up on your feet quickly and throw his left ankle up and under your right armpit. See Plate 41. And grasp his shin with your left hand—and grasp your own left wrist with your right hand.

Finish him off by lifting your man up on his head while you lean backward. If something stronger is needed to quiet him you can place your left foot on his throat.

Again it should be repeated that each step in Ju Jitsu must follow the previous step automatically and without the least trace of hesitation. Practice and practice until you can almost "feel" how one move follows another. You can't think it out while the battle is on!

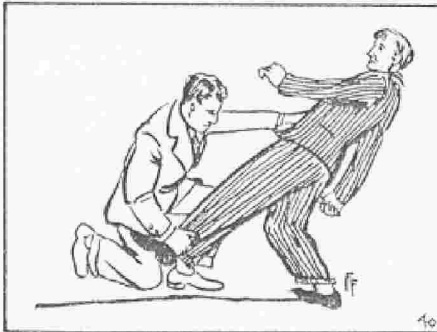

Plate 40



Plate 42

As a variation from the leghold illustrated in Plate 41 you may seize his toes with your left hand and his heel with your right hand. Twist his foot quickly to your left, turning him over on his stomach.

In doing this place your left leg into the hock of his left leg. Kneel down behind him so his foot is resting in the pit of your stomach or against your chest as illustrated in Plate 43.

Your leaning forward will cause him unbearable pain and make him cry out for mercy.

The series of movements in getting this leg hold is simple when you have it well in mind. As a practice to develop your speed do this: Get close to a wall and see how quickly and well-timed you can complete the step of dropping to one knee, gripping an imaginary assailant's ankle with your right hand and striking the wall (solar plexus) with the heel of your left hand.



Plate 43

43



Plate 41

### A Powerful Arm Hold Without Handcuffs

#### LESSON 23



Plate 44

44

This fool-proof hold is for policemen, theater ushers, doorkeepers and other attendants who may want to hold a rowdy without using handcuffs.

Face the disorderly person and instantly seize his right elbow joint on the outside with your right hand. Pull his elbow quickly toward you. And in a flash get your left hand up against his right wrist. This is illustrated in Plate 44.

Continue your movements by forcing his forearm up behind his back. Then get abreast of him so he cannot strike or kick you. Plate 45.

Keep the weight of your body close in toward your man and with your left hand gripping his upper arm and your right hand at his elbow joint—you now have him where, without effort, you can hold him, you can march him off to the police station, or you can simply put him outside on the sidewalk.

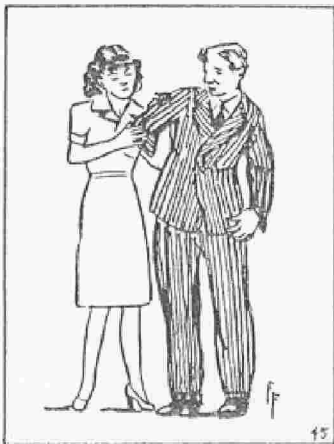

Plate 45

This will not injure him. But if he resists let him know you are his master by bearing downward toward the ground with your right hand at his elbow and upward and outward with your left hand at the upper arm.

Before it is necessary to force a shoulder dislocation he will likely quiet down for you.

### How to Master the Situation When You are Grabbed and Held by Both Your Wrists

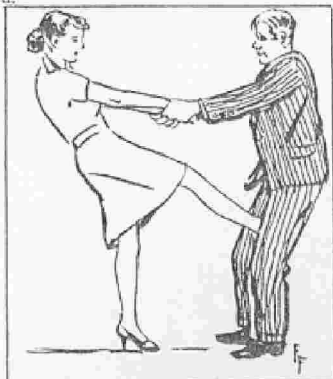

Plate 46

LESSON 24

Your movements are the same whether you are seized by the shoulders, held by both wrists or an attempt is made to strangle you by your coat lapels.

Instead of making an effort to get yourself free all you need do is deliver a blow to your assailant's scrotum with your knee or your foot. Not much force is needed behind this blow to the crotch.

The strongest and biggest man will crumple to the ground in agony. Not a pleasant operation—but necessary, sometime, to defend your own life. Plate 46.

### Quick, Easy Way to Disarm a Gunman



Plate 47

LESSON 25

Should you be threatened by an armed assailant or one who likes to use his fists here is an easy way to subdue him and discourage further criminal plans on his part.

Facing your attacker you catch his right wrist with your left hand as shown in Plate 47. Lift his forearm upward so his elbow forms a right angle.

Bring up your right hand behind his upper right arm and seize his wrist with your right hand. Your left hand can come down.

You see from the illustration that your man is now secured and helpless.

Using your forearm as a lever you can bear downward with your hand at his wrist. A certain amount of pressure will dislocate his shoulder.

*The great art to learn much is to undertake a little at a time.—Locke*

*So live that you can look any man in the eye and tell him to go to hell Knowledge is a treasure, but practice is the key to it.—Thomas Fuller*

*Nothing is so much to be feared as fear.—Henry David Thoreau*

*Unlike the poet, the successful man is not born.—John Wanamaker*

*You will never "find" time for anything. If you want time, you must make it.—Charles Dutton*

*A wise man will make more opportunities than he finds.—Bacon*

*Success does not consist in never making blunders, but in never making the same one the second time.—H. W. Shaw*



Plate 48

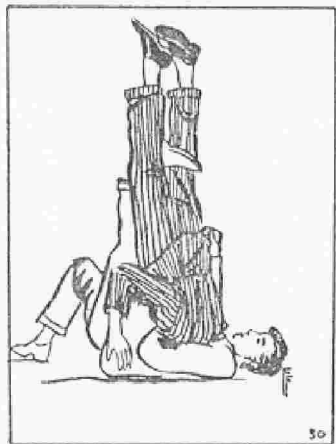

Plate 50

Keeping your hold around his throat with your left forearm, strengthen your grip by clutching your own left wrist with your right hand.

Increasing pressure on this hold would strangle the man.

### Head Over Heels and He's Out



Plate 49

#### LESSON 26

The assailant may want to butt you in the stomach or face with his head. In this case you can make his position boomerang on him—and cause it to defeat him.

As he seizes you in the front or rushes at you with his head down get your feet well planted and prepare to meet him.

Catch him at the back of his neck with your right hand and force his head under your left armpit. See illustration in Plate 49. Grip your left arm around his neck tightly and then get a hold on his belt or the seat of his trousers with your right hand.

Quickly fall backward and sit down. In doing this bring your left foot up (see Plate 50) and throw your man head over heels until he strikes the ground.

### Over-Powering an Attacker who Gets You Down and Attempts to Strangle You



Plate 51

#### LESSON 27

In a rough and tumble bout it is not unusual to find yourself flat on the ground with the assailant on top. He may even try to strangle you.

Tightly clasp your right hand around his right wrist and place the palm of your left hand at his elbow joint. Details are shown in Plate 51.

Then turn your whole body over quickly to your right. This will force the culprit over on his stomach. Keep your grip on his arm with your hands. Jump up quickly and place your left knee on his upper arm, bending his forearm around toward you. This is made clear in Plate 52.

Forcing his forearm straight to your front will make him give up—or will dislocate his shoulder.



Plate 52

### Holding Down a Very Strong Man By Nerve Pressure



Plate 53

#### LESSON 28

Suppose you find yourself on the ground battling with a very powerful man.

Get on top of him as explained in Lesson 27—or in any other way—place the heel of your left hand under his chin and turn his head away from you.

At the same time place the thumb of your right hand on the nerve center that is situated close up under the Lobe of his left ear. Plate 53 shows the position.

Pressing downward toward the ground with your thumb will cause your assailant very severe pain. Continued force will result in unconsciousness.



Plate 54

#### LESSON 29

### The 100% Effective Leg Strangulation Hold for Use On Powerful Men

It may happen that in your encounter with an assailant you are unable to get on top of him as directed in the previous two lessons. In such a case simply keep him from getting a hold on you. Continue rolling about on the ground.

Then work around to a position where you can get his neck close up in the fork of your legs. When you have done this your enemy is as good as captured already.

Cross your feet and straighten your legs out rigidly. This will secure him in a very powerful leg strangulation hold sometimes called the Neck Scissors hold. See Plate 54 for details of position.

In practicing this hold with a friend be extremely careful. Watch his face. If it grows red you have stopped his breathing—so let up on the pressure instantly.

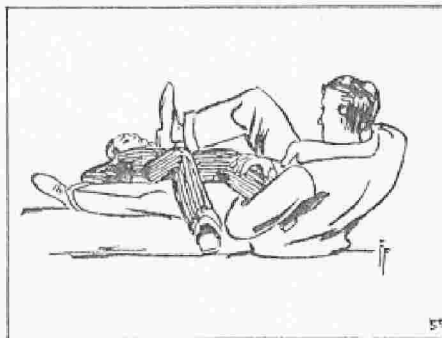

Plate 55

#### LESSON 30

### Vise-Like Ground Leg Hold

This is another excellent method of holding an assailant down on the ground during a rough and tumble,

You work around to get in position, avoiding any grip he might

get on you. Keep moving.

Then encircle your left arm over and under his left leg. At the same time with your right hand seize his left leg half way between the knee and foot. Finally grip your right wrist with your left hand.

Bring up your right foot and place it on the pit of his stomach. You then have an extremely powerful leg hold on your man.

If he resists wedge his leg tightly under your armpit and lean backward. The whole weight of your body will rest on his foot. At the same time you can deliver a blow with your foot to his stomach or groin.

This will finish him in double-quick time.

It does not matter much whether you start to work on his left or his right leg. Do whatever seems easier for you. But practice only one so you will become expert and will not find yourself hesitating when actually using this hold in battle.

## How to Throw Any Man with An Easy Hand Twist



### LESSON 31

Plate 56

Even a girl without much strength can throw the strongest man to the ground by using this grip. And with a little added snap she could break his wrist if necessary.

As the assailant faces and threatens you grasp his right hand with your left hand. Your fingers in the palm of his hand and your thumb at the back of his hand.

Lift his hand upward toward yourself and come up with your right hand, placing your fingers and thumb in the same position as your left hand on the other side of his right hand.

This brings the fingers of both your hands in the palm of his hand and your two thumbs on the back side of his hand, one inch below the knuckles each side of the middle finger. These two spots are nerve-centers, as you have already learned. See Plate 7 to refresh your memory.

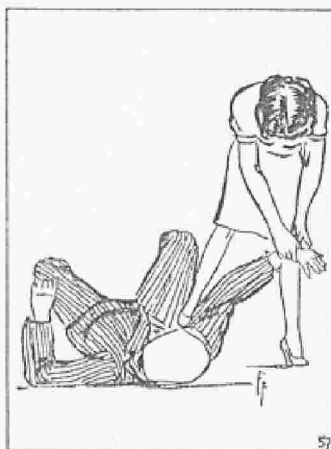

Plate 57

Then quickly straighten out his arm and twist his hand downward and outward toward the ground. Illustrated in Plate 56.

He cannot help himself and will fall to the ground. The moment he hits the ground place your right foot close up under his armpit. This prevents him from twisting. At the same time keep his arm up straight and force your thumbs downward toward your fingers, as if you were folding a sheet of paper. Twist his whole arm outward.

Continued pressure will cause the biggest wrist to break. Final position illustrated in Plate 57.

## How a Girl Can Capture A Purse-Snatcher



### LESSON 32

Plate 58

You are walking along the street and a man molests you by seizing your wrist, snatching your bag, or clutching your shoulder.

Say your assailant is on your right side as shown in Plate 58.

Instantly spin right about. Now facing the opposite direction catch your assailant around the waist with your left hand and place your left foot behind him as shown in Plate 59.

Continuing your movement, bend downward quickly to your right. This will send your man sprawling to the ground. Shown in Plate 60.

This buttock throw will take him entirely by surprise. And he will hit the ground with such force he is not likely to get up right away.

At this point, while he is down, you may if you wish apply one of the holds taught in previous lessons.



Plate 55



Plate 60

When you step behind the man (Plate 59) be sure you let balance help you. Get far enough behind him to make him lose his balance—and to enable you to swing him without much effort, balance doing the work.

## Winning by Winding



Plate 61

### LESSON 33

This hold starts with you in a very disadvantageous position—the assailant has both his hands at your neck.

Instantly clasp your right hand around your attacker's right wrist. The palm of your left hand goes under his elbow joint. By this time you should be very familiar with this operation. Illustrated in Plate 61.

Quickly turn right about. At the same time bear upward with your left hand under his elbow and wind your assailant's arm close in and around your waist as shown in Plate 62.

Then quickly jump straight forward to your left front and sit down on the ground. This movement will throw your assailant down on his face with your back resting on his back. The entire weight of your body is resting against him. See Plate 63.

Keep his arm bent round and close in to your body, with your left hand at his elbow. Force his knuckles downward toward



Plate 62



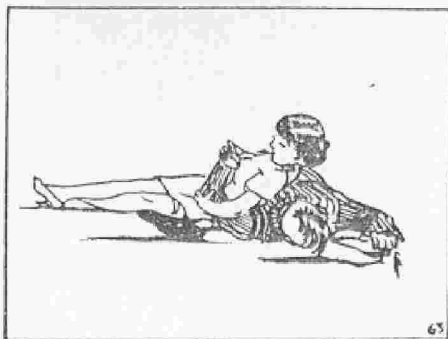

Plate 63

his elbow—and at the same time force his forearm upward then over to your left, keeping the forearm straight up.

The final result on your assailant is a broken wrist, a dislocated shoulder, and perhaps a few missing teeth because of the way his face hit the ground.

### "Katsu"— Restoring Consciousness To an Unconscious Person

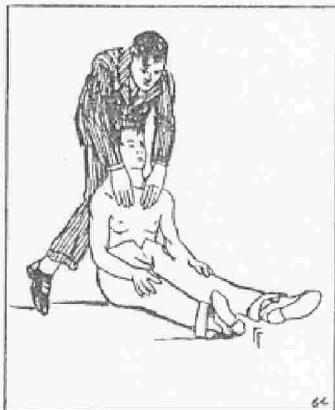

Plate 64

#### LESSON 34

Raise the unconscious subject to a sitting position, stand behind him and support him with one of your knees. Then place your thumbs at the pectoral arch. You will locate it by feeling for the two hollows at the shoulders close to each side of the neck. For position see Plate 64.

With your thumbs placed let your fingers rest firmly on the chest. Pressure is then given with both fingers and thumbs with upward and downward movements. Move fingers upward on the chest and press the thumbs downward on the pectoral arch.

Fingers must not slide over the skin. Rather, they should move the skin and flesh up and down with them.

It is said the effect of this pressure tends to stimulate the nerves of the heart and also cause the diaphragm (in chest) to expand and contract which helps to start the subject to inhale and exhale.

While this pressure is being applied to the chest with the fingers a sharp blow should be delivered with your knee on

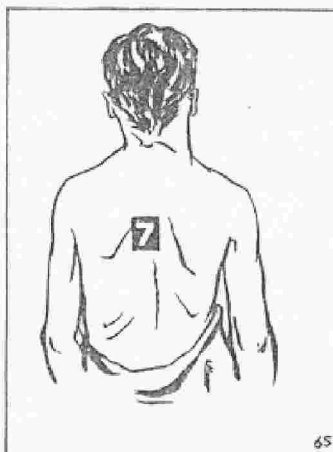

Plate 65

about the seventh dorsal Vertebra. This would be very nearly the middle of the backbone, slightly higher. See Plate 65.

This, it is said, tends to stimulate the Pneumogastric nerve and assists in causing the diaphragm to expand and contract.

The inhalation and exhalation thus brought about in some way helps the heart along. Also, it aids the circulation of the blood.

Another point on the backbone where a blow might be landed is the vertebrae third from the bottom of the spine.

If you know the unconscious person's name it is well to call to him as weak movements begin. This will help some in getting his mind working again.

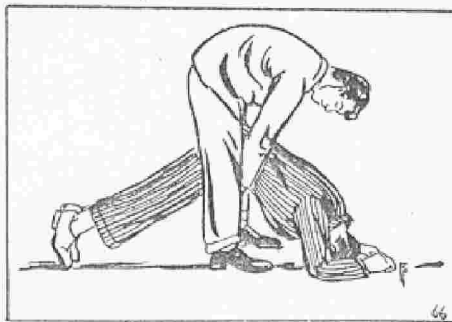

Plate 66

In cases of people being rescued from drowning the American Red Cross method of artificial resuscitation is most effective.

The patient is laid prone on his stomach, face to one side and mouth open. Then an effort is made to get him to breathe.

In nearly every case the patient needs oxygen (either from the air or from a tank) in his lungs. He definitely does not need water taken out of him as it practically never enters.

Continued next issue

# SUPER Ju Jitsu

Copyright 1942

## The Escape-Proof "Come Along" Hold



Plate 67

67

You will find this clamp-like hold most effective in taking violent culprits to a police station or other place of safe keeping. It is invaluable knowledge for police officers.

Standing beside your man grasp his right wrist with your right hand and lift his arm straight out in front in a horizontal position. In doing this encircle your left arm over and under his upper arm and clasp your own right forearm with your left hand. Shown in Plate 67.

Should your man become violent wedge his upper arm tightly under your left armpit and bear downward with your right hand at his wrist. Make sure the palm of his hand is up.

This continued pressure will break his arm.



Plate 68

68

Now to come into a very painful wrist lock from the arm hold allow his arm to bend at the elbow joint that rests on your chest. Then with the palm of his hand downward and with the palm of your right hand over the knuckles of his right hand let your left hand grip hold of your right upper arm as shown in Plate 68.

To make him submit—or end with a broken wrist—force the knuckles of his hand inward toward your chest. (Don't forget to be gentle in practice.)

\* \* \*

Following these two holds you may want to throw the man because of his becoming too violent. It's easy.

Hold your grip just as you have it then quickly turn inward and left about, facing the opposite direction. At the same time

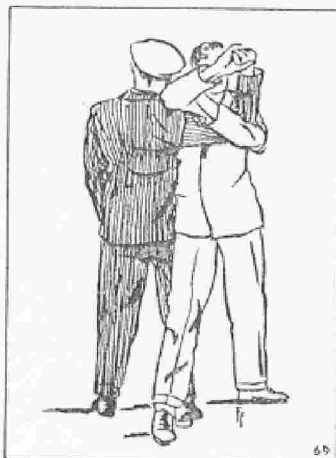

Plate 69

69

lift his and your own arms upward and place your right foot behind his right foot. This is made plain in Plate 69.

Force your man backward with this dislocation-of-the-shoulder throw. He will automatically fall backward over your foot, sprawling on his back.

\* \* \*

To complete the dislocation arm hold, the moment he hits the ground (you are still holding him) place your right knee on his shoulder and straighten his arm out to three-quarters length as shown in Plate 70.

Lift upward with your left forearm and round to your left with your right hand at his wrist. He will give up or he will end with a dislocated shoulder.

\* \* \*



Plate 70

You have him helpless on the ground now and may want to slip hand cuffs (bracelets) on him.

Place your right knee on his upper arm and allow his forearm to come straight so that his arm represents the letter L. Put your right hand over the knuckles of his hand as shown in Plate 71.

Tell your man to bring his left arm over so you can handcuff both his wrists together. If he refuses—as he probably will—just bear downward with your right hand on the knuckles of his hand. It won't take much pressure to make the man see your point.

As it takes so little pressure to break a wrist don't be too enthusiastic with your friends in practice.



Plate 71

The five-in-one combination just outlined is perhaps the most effective Ju Jitsu hold ever developed. One after another you have 5 powerful positions—any one of which is perhaps strong

enough to carry out your intention. If your assailant knew you had 5 such rabbits to pull out of the hat he certainly would avoid tangling with You.

## Disarming The Hold-up Man

### LESSON 36



Plate 72

The criminal may have a gun, knife or club. But here is a quick and effective way to disarm him and avoid injury to yourself.

Seize the wrist of the hand holding the weapon. This is usually the right. Seize it with your right hand, and lift his arm upward and straight out in front.

At the same time place your shoulder close up under his arm and place your left hand on your hip. This last move prevents the man from coming forward.

Stand erect and make yourself as tall as possible. Then quickly pull downward violently with your hand at his wrist as shown in Plate 72.

This movement will not only *disarm* the assailant but if you use a little extra force his arm will break.

## Flying Tackle with Double Leg Lock

### LESSON 37



Plate 73

This is a good example of how you must act instantly, seconds before your assailant even knows you are thinking about resisting.

In this instance dive at his feet and seize both his ankles with your hands. This is easy provided you do it without first glancing to the ground and giving yourself away.

On your way down to his feet butt him in the solar plexus with your head. Yank his feet forward and send him sprawling on his back.

As he is falling you bounce up and place both his ankles under your armpits. Lift him up and down so that the weight of his body rests on his head as in the illustration, Plate 73.

This position brings the outlaw's weight on a pivot, making it easy to twist him over on to his stomach.

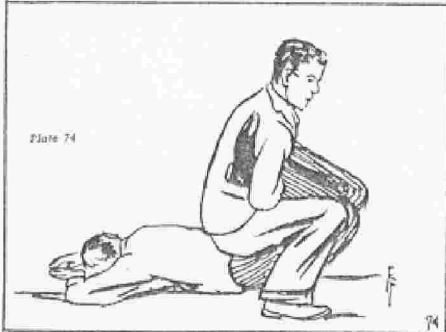

Still keeping his ankles under your armpits turn left about by twisting your man over on his stomach. As he is turning over step over his body with your right leg.

As soon as the turn is completed sit down on his buttocks and lean backward toward his head, allowing the weight of your body to rest on his feet as shown in Plate 74.

This will cause intense pain which will seem to run up his spinal column.

You may, if it is desirable, apply this hold to one leg instead of two. Results will be about the same, except that you will have a free leg to watch.

#### LESSON 38

Escape is impossible with this method of throwing an assailant and holding him by this powerful arm hold.

Facing the man who attacks you seize his left elbow joint with your right hand and throw his forearm up and under your right armpit.

At the same time bring your right hand up under his upper arm and grasp his clothing—coat lapels give a good grip—with your right hand. Jab him under the chin with the heel of your left hand as illustrated in Plate 75.

Then place your left leg behind his left leg and force him down on his right side, still holding on to him, of course. This brings him down in front of you on his side and close to your feet.

### Quick Arm Hold and Throw



Plate 75

From this position step over his body with both feet so that his arms come up between your legs. Then sit down on his left



side and allow your left hand to grip his upper arm and come into the arm hold as shown in Plate 76.

Sit upright, lean back and your man will lose all his fight.

### The Devil's Handshake Or How to Act On Friendly Terms with An Enemy

#### LESSON 39

Plate 77

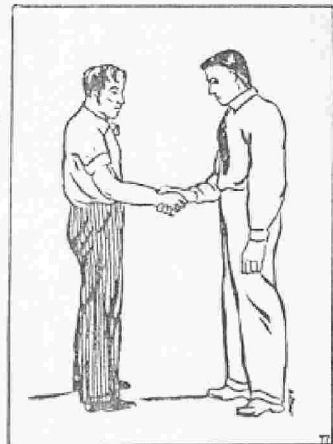

Shake hands in the usual way (Plate 77). But instead of letting go of his hand turn quickly right about. In so doing bring his upper arm to rest on your left shoulder. And strengthen your grip by seizing his arm at the elbow joint with your left hand.

Bend your legs at the knees and come into position as shown in Plate 78.

You can send your man flying over your head this way. Straighten your legs with a jerk and pull downward toward the ground with his arm. Bend the trunk of your body downward in a horizontal position.

If done with determination you will not only send the thug hurtling over your head and on the ground but in addition his arm will be broken and unfit for further fight.



Plate 78

It is not necessary that you throw the man over your head in this series of movements. You can disable him, breaking his arm, by merely pulling down on his arm while you are standing up tall as possible.

### Special Superior Leg Lock No. 1

#### LESSON 40

Plate 79



Make an instant flying dive, one hand to the ankle the other to the solar plexus. As your man is falling backward stand up, get his left leg up under your right armpit.

Allow your right forearm to go under his leg and your left hand on the shin. Then seize your own left wrist with your right hand as shown in the position illustrated in Plate 79.

At the same time lift the man up on his head, which acts as a pivot, and turn left about.

As the man is turning over you will instinctively step over his body with your right foot, bringing you standing astride him.

To cause submission stand erect and lean backward. At the same time, without moving your feet, twist the trunk of your body around to the right. Your right foot on the back of his neck. See Plate 79.

This will dislocate his knee cap.

### Special Superior Leg Lock No. 2

#### LESSON 41

Plate 80



As this formidable hold is twice as painful as that taught in lesson 40 you should have a friend apply it on you before you start using it seriously.

This leg lock and knee dislocation is a 2-in-1 combination attack.

You throw the man with the flying dive already taught—twist him over on his stomach—wedge his left leg tightly under your right armpit by the method illustrated in Plate 80.

Then stand erect and lean backward so the weight of your body rests on his foot.

Without moving your feet, twist the trunk of your body to the right. The result is a painful dislocation of your assailant's knee.

*That man is great who rises to the emergencies of the occasion, and becomes master of the situation.—Down Platt*

*It is a great art to be superior to others without letting them know it.—H. W. Shaw*

*Man thinks, and at once becomes the master of the beings that do not think.—Buffon*

## The Super Powerful Arm Hold



Plate 81

81

### LESSON 42

Not only is the grip illustrated in Plate 81 extremely powerful it has the added advantage of being easy to apply against many positions from which you may be attacked.

You may use moderate force on this hold and make it just painful enough for your assailant to make him give up. Or you may use more force, if he becomes violent, and break his wrist and dislocate his shoulder.

You start your defense from the position of your being attacked with a deadly weapon—or with hands at your throat to strangle you.

Be sure your left leg is well bent as illustrated. This gives you more leverage and multiplies your strength.

The routine step by step procedure is familiar to you now as it has been outlined in several previous lessons.

## Flying Scissors Double Leg Throw

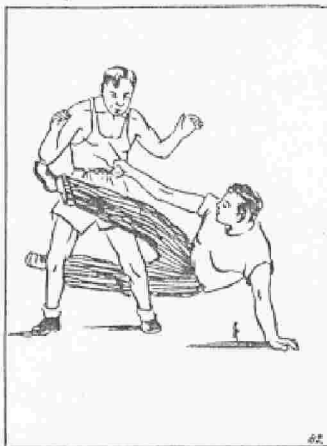

Plate 82

82

### LESSON 43

When you want to get the assailant down very quickly use this method. It is really a wrestling attack used in American wrestling regularly. Except that the wrestlers do not apply the leg lock to be explained.

Getting to one side of your man, throw up your right leg with a spring. Bring it up to a point along his waist. At the same time bring your left leg up behind your assailant's legs just above the back part of the knee. See Plate 82.

With these combined movements twist the whole of your body right. Your man will quickly be thrown on his back.

Come up into a sitting position without hesitation and secure his left leg up under your armpit. At the same time place your right hand below his knee and place your left forearm under his leg. Grip your own right forearm with your left hand.

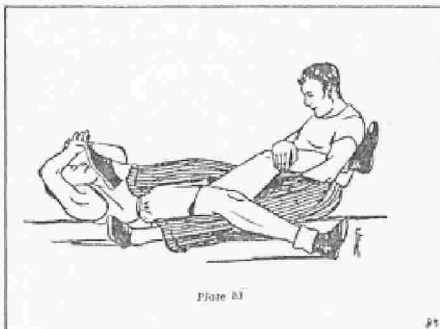

Plate 83

83

Now you wedge his leg tightly under your armpit and lean backward so the weight of your body rests on his left foot. This is illustrated clearly in Plate 83.

Your right foot is resting on his stomach or solar plexus where a blow may be given with your foot.

In learning this series of movements you might find it more convenient at the beginning to get your legs in scissor position without the jump. Then after you get the general idea well in mind you can attempt the scissor flying rather than just standing.

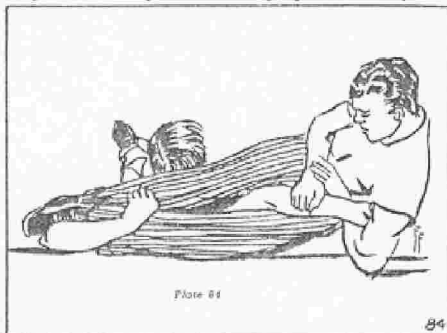

Plate 84

84

### LESSON 44

## Outlaw's Crucifixion

Double leg Nelson and double arm Nelson would be the wrestling term for this escape-proof hold. Wrestlers sometime use the double leg Nelson but not the double arm lock.

You will use this Crucifixion hold after you have been attack-



ed and find yourself rolling around the ground in battle with the culprit.

The assailant must be worked into a position flat on his stomach or the hold may be started with the assailant on his hands and knees. You will get him in this position when you give him half a second free so he can start to get up.

As he kneels—down on all fours—get close to him on his left side and place your left foot between his hands. Then bend over his back seize his right wrist with both your hands and pull him over on to his back. While doing this you turn completely on your left side and lie down.

Bring up your right leg and place it at the back of his neck and lock his left arm again with your right foot. (You lock it the first time as you go over backward.) Then form a double lock about which you have already learned.

Study the positions illustrated in Plate 84. This shows how you next lock his right arm under your left armpit.

Try it in practice a few times. You'll be surprised how smoothly one step follows another!

To make the outlaw quit simply lean backward, allow your entire weight to rest on his arms—and at the same time stiffen your legs.

The pain is terrible. He will not be able to bear up. If he does resist, though, just a little bit more pressure on your part will break his arm.

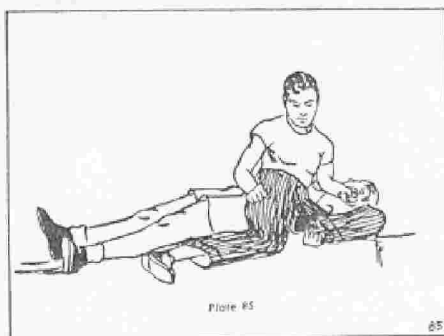

LESSON 45

### Combination Leg-Arm Ground Lock

One of the chief advantages of this type of hold is the speed and ease with which you can apply it while both you and your attacker are fighting on the ground.

You can start this hold from the worst possible position you might find yourself in—flat on your back. Turn quickly to your left and sit down, upright, with your back against his left side and as near his head as possible.

Secure his left arm and bring it over the upper part of your leg. Keep his arm out straight. Then bend your left leg inward

and bring up your left foot so that it will rest on your assailant's left wrist.

At the same time allow your left forearm to rest across his throat. At the Adams Apple as illustrated in Plate 85.

The final step is for you to cause your left knee or leg to bear down toward the ground and put your entire weight on the forearm across his throat.

He will not be able to cry out but his kicking and squirming will quickly tell you he has had enough.



LESSON 46

### Slip-Proof, Powerful Arm Lock

You can do real damage to an assailant using this hold. Just moderate pressure will snap his arm at the elbow—just as easy as breaking the stem of a wine glass.

This hold is a good one to use if you have fallen after missing some standing grip. Take your man with you and start working on him while both of you are down.

Turn the man on his back, throw your legs over his body; your right leg across his throat and your left leg across his chest. Then secure his left forearm close up under your right armpit.

At the same time encircle your right forearm over then under his arm so that your forearm is under his elbow joint. Your left hand will be gripping his upper arm and your right hand gripping your own left arm.

You can finish your job quick by wedging his arm tightly under your armpit and leaning back so that the entire weight of your body rests on his arm. In doing this, bridge your own body off the ground.

The position in Plate 86 shows the assailant more on his right side as he lays on the ground. This is merely so the arm lock shows up more clearly. In practice follow the instructions more closely than you follow the picture. (This lesson only. In all other lessons you follow the illustration even more than you follow the text.)

## Defending Yourself Against Flying Fists

LESSON 47

Plate 87



The main thought behind this defense is to keep from getting knocked out. After you get right up to the bully, regardless of his size, you can use any one of a dozen sure holds to stop him cold.

In fact, the only way a fighter can ever defeat a good Ju Jitsu man is by landing a knock-out punch before a hold is started on him. After that he knows, as you well know, that his goose is cooked.

Get your hands up to your face as illustrated in Plate 87. Punches that hit your hands a sliding blow will not do you any serious damage. But get in there quick and start to tie him up quick before he can land more than one blow.

Don't let him get behind you.

One of the best things to do first is go at him with a flying dive. But you know many good ways to start.

The object of placing your forearms and hands in front of you as pictured is to protect the jaw and the solar plexus especially.

*An ounce of courage will go farther with women than a pound of timidity.—Balzac*

## Modern Mechanic February 1934, New Rifle Shoots Beam of Light



"Shadolite" gun, invaluable for target practice, shoots a beam of light. An electric eye behind hole in bull's eye of target operates signal when hit by light beam of gun.

**A**N INVENTION of considerable interest to rifle enthusiasts is the "Shadolite" gun. Without ammunition of any kind, this new gun registers bull's-eyes and misses just as does an ordinary rifle.

A powerful flashlight mounted inside a nine gauge shotgun flashes a beam of light at the target for any set interval of time ranging from zero to 30 seconds. A photo-electric cell mounted behind a hole in the center of the target causes a relay to operate when the rifle is correctly aimed, thereby lighting a signal lamp. The aim of the gun may be corrected within the time length of the bullet beam.

## Popular Mechanics July 1955

### Compact Kit Plates Metal

Two miniature batteries contained in a metal case provide the electricity for a compact, economical, electroplating set. Attached to the battery case is an anode which is placed in the electroplating solution. Another wire leads from the battery case to a crocodile clip and a hooked copper wire for holding rings and other small objects in the solution. The instrument applies a silver, copper, gold, rhodium or chromelike finish.



# SUPER Ju Jitsu

Copyright 1942

## Ju Jitsu vs. Boxing

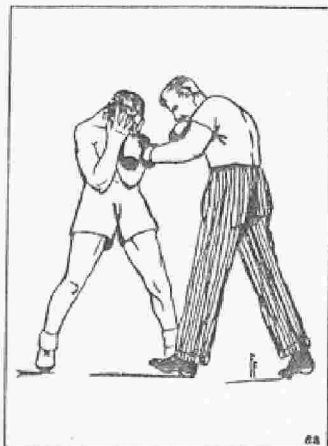

Plate 88

### LESSON 48

This lesson covers the subject of "The Mixed Bout."

It was not mentioned in lesson 47 but you should keep your fingers slightly apart when you place them over your face for protection. First, your hand will cover more surface and second you will be able to see what's going on. See Plate 88.

As soon as you are in close quarters, quickly drop down on your right knee and deliver a blow to the Solar plexus with the heel of your left hand—and at the same time grasp the ankle he has farthest advanced with your right hand. Pull upward with your right and push backward with your left hand.

He will be thrown off balance as illustrated in Plate 89.

As he is going down backward you stand up, place your left hand on the toe of his foot and twist his foot over to your left. This will turn your man over on his stomach.

Kneel down behind him at once and rest on your right knee—and lock your left leg in the back of his knee joint on his left leg. His left foot will come up into the middle of your stomach.

To make him quit—lean forward toward his head so that the whole weight of your body rests on his foot. This is made clear in Plate 90.

*Don't stop trying! Remember, it is usually the last key you try that turns the lock.*

*The grooves that lead to the heights are not made between nine and five. They are burned in by midnight oil.—Owen D. Young*

*All wish to possess knowledge, but few, comparatively speaking, are willing to pay the price.—Juvenal*

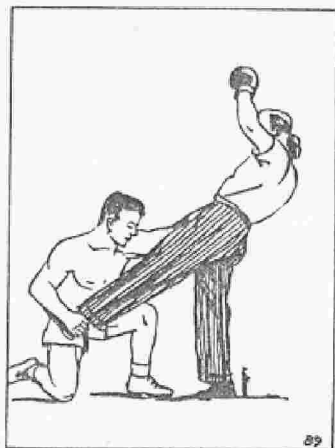

Plate 89

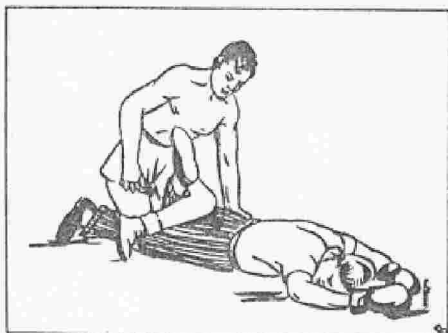

Plate 90



Plate 91

Here is another good way to bring the boxer down and start him on the road to his defeat.

Get in close to your man with your left foot advanced and your body inside the boxers left lead.

Like a flash and using your left foot as a pivot, turn left about and bring your right arm around the boxer's neck over his left shoulder. At the same time grasp your own right wrist with your

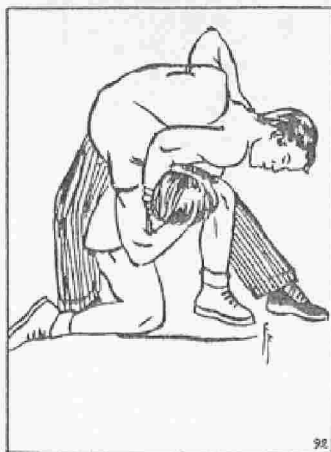

Plate 92

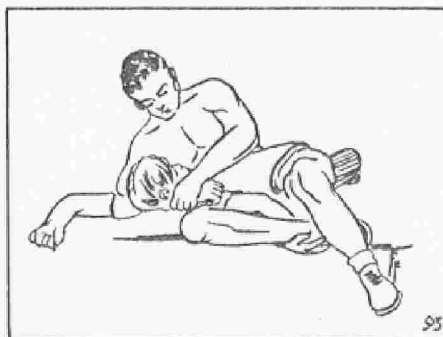

Plate 93

left hand and keep turning left as far as possible so that your left side is close in against the boxer's stomach as shown in Plate 91.

Keep holding your own wrist and kneel down on your outside knee (in this case your right knee.) With a good tight grip around the boxer's neck, twist your whole body to the left with a snap. See Plate 92.

This will force your man over your back and on his own back, keeping your grip just as it is force your chest or full weight of your body on his chin. Apply the strangle hold and leg arm lock as shown in the illustration.

*Self-confidence is the first requisite to great undertakings.—Johnson*

*Take care to get what you like or you will be forced to like what you get. George Bernard Shaw*

## A Powerful Walking Hold From Which A Criminal Cannot Break Away

### LESSON 49

Plate 94



There are cases where you may have your assailant locked up tight while both of you are laying on the ground—but if no one is around to help you what should you do then?

Here is one answer. Get the following hold on him and march him off to a police station or some other place where you can get help, if necessary.

Standing abreast of your man on his left side grip his left arm at the elbow with your right hand and throw his forearm upward behind your back.

As his arm is coming up seize his wrist with your left hand. At the same time allow your right hand to go under his arm and through and over to his right coat lapel.

Then close your hand tightly on his coat lapel with your knuckles inward. This movement brings you with both your arms crossed. (Plate 94) Your arm is outside his.

Force him away from you by standing erect. Push him away



Plate 95

to your arm's length. He cannot now strike you with his free right hand. See Plate 95.

If he gets rough and needs a lesson, keep holding him, turn right about and place your left foot behind his left foot. Throw him as explained in lesson 15 and illustrated in Plate 31.

You might have occasion to hold and walk a man who is drunk. This will make some kind of support necessary.

A helper can get to the other side of your man and get a grip on him similar to yours. You will then be holding the man up and walking him at the same time.

If he is violent—or if he is absolutely unable to walk, another helper (now 3 of you) can get behind the man, grasp both his ankles and pick him entirely off the ground. This third helper can keep away from the drunken man's feet by walking between his legs as the man is being carried face downward, flat out.

## Your Sure Defense Against a Full Nelson Hold



Plate 95

96

### LESSON 50

There are times when you meet up with an assailant who knows a hold or two that he springs on you while you are unaware.

Still a common trick is for two robbers to work together, making their work less hazardous, they feel. One sneaks up behind you and tips your hat forward over your eyes.

You naturally bring both arms up to adjust your hat—and one robber applies a full Nelson as shown in Plate 96. The confederate can then appear on the scene and rifle your pockets.

Get the man in front first. Bring up your knee or foot with force and deliver a good blow to the assailant's scrotum. That will count him out in double-quick time.

Then bend your trunk forward and downward into a horizontal position. Make a complete left turn and step backward with your left foot. Place your left foot behind your assailant's right foot.

Now seize his two legs at the knee with both your hands and lift your man up off his feet. As you do this your leg will automatically bend at the knee, on which his body will rest for a moment. (Plate 97)

Then throw your man with force away from you around behind



Plate 97

your back. This will be toward your right foot. But don't move your feet at all.

You will now find yourself master of the situation and, if necessary, you can break his wrist as explained in lesson 7 and illustrated in Plate 10.

## Speedy Combined Arm and Leg Throw

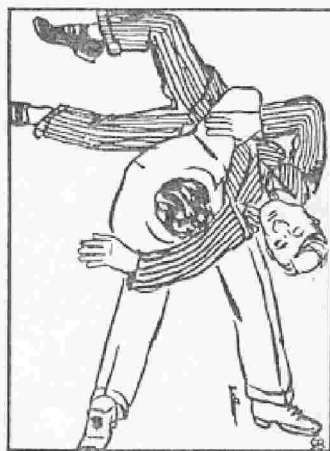

Plate 98

99

### LESSON 51

Sometimes this is called the "Buttock Throw" and "Arm Hold and Leg Strangulation." Whatever you call it, here is a quick sure way to stop an assailant who attacks you from the front.

Grasp his upper arms, step behind him with your left foot coming into a position of balance and give him a good buttock throw. See Plate 98.

Swing your trunk downward to your right front and at the same time pull upward with your right hand so as to get his head clear of the ground.

This movement makes it possible for you to hook the hock (back of knee joint) of your right leg around his neck.

Continue by keeping your right leg bent at the knee and sitting down on your own right heel. Then extend your right leg

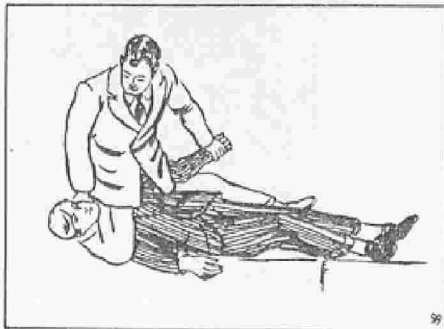

Plate 99

out full length with the elbow joint of his left arm resting on it.

Sit backward to allow your weight to come across his throat and bear downward with your left hand at the wrist, as shown in Plate 99.

## How to Stand Your Attacker On His Head

### LESSON 52

Plate 100



It is desirable, sometimes, to repay a tough roughneck with a bit of your own educated muscle.

You throw your man into position but you do not use the Arm Hold and Leg Strangulation taught in lesson 51.

Use the regular balance throw (which you already know) illustrated in Plate 100. As he is falling to the ground allow your arms to relax slightly so that your assailant's legs will go through your arms as he travels head downward.

The same moment he strikes the ground, place your right foot on his chin and secure his legs as shown in the position illustrated in Plate 101.

This is really comical because it brings the tough guy straight up and down, *standing on his head*.



Plate 101

He will give up when you raise him and drop his head a few inches 2 or 3 times. Be sure you leave your foot on his chin to keep him from bending up forward!

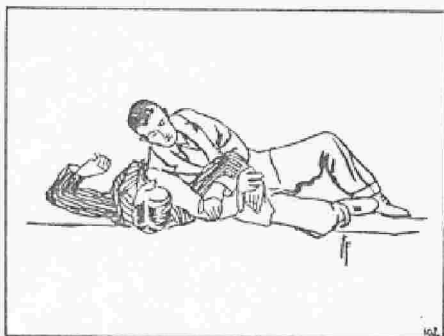

Plate 102

### LESSON 53

## Pinning Your Assailant to The Ground

Very powerful and effective, this arm hold is used when you want to secure your enemy during a rough and tumble on the ground.

Grasp his right wrist with your right hand and grasp his forearm with your left hand. Then get your own forearm more or less under his elbow. Keep his arm bent at three quarters arm's length as in Plate 102.

With your right hand at his wrist bear away toward your feet—and bear upward with your left forearm under his elbow joint.

Increasing the pressure even *slightly* will dislocate his shoulder.



## LESSON 54

**How to Throw An Assailant 9 to 10 Feet**

Commonly called "The Stomach Throw" this is used when your man makes a rushing attack at you.

Seize your assailant by his upper arms or coat lapels. Then bring your right foot to the pit of his stomach. The knee will be bent slightly and your foot will be against his stomach.

Continue the movement by first going backward and down on the ground in a sitting position. Then continue going backward and see how far you can throw your assailant over your head. After he has ridden your right foot over your head give your last good push and release your grip.

You can throw him 10 feet or more with a good start!

If you keep your grip on his upper arms or coat lapels after he has gone over your head you can yourself go head over heels and come over sitting astride your assailant.

You will then be in position to apply any one of the holds or locks you already know for this kind of situation.

## LESSON 55

**What to Do When You are Held by Both Wrists**

Should you be seized by both your wrists instantly clench both fists.

Then make a circular movement with them by twisting them outward, inward, then upward toward your own face.

This simple movement will break the grip of the strongest man. The secret is that you are actually using the full strength of your two arms against only his two thumbs.

After breaking his grip you may use any one of several good holds, perhaps the best being one of the effective arm holds taught you in earlier lessons of this course.

## LESSON 56

**Your Head in Chancery—How to Break Out**

It usually means much punishment if your attacker gets your head under his left armpit and gets his right set to smash your face in.

But if you act quick you can avoid even the first blow by placing your left hand with fingers extended and spread over your face.

At the same time place your right foot behind your assailant's left foot. Extend the fingers of your right hand and bring your hand up sharply from behind and over his shoulder and then under the cartilage of his nose with a brisk chopping movement upward and with force.

Then instantly kick his left foot from under him with your right foot. He will go sprawling on his back.

This is one sure way and easy way of getting out of a hold that might bring you a terrible beating.

## LESSON 57

**How to Handle a Running Attack, Armed or Unarmed**

When you are about to be attacked by an assailant suddenly rushing at you like a bull coming out of his gate—you will have to know what to do—and you will have to do it without hesitation.

Avoid being knocked over. Wait until he is about three feet away from you then throw yourself, forward and downward, full length in front of his feet. This movement on your part will upset his balance making him go over your back and flat on his face.

Get up behind him quickly and place his left leg over into the hock (back of knee joint) of his right leg. Then raise his right foot and lift his leg forward toward his buttock and lock his left leg with it.

To make him quit—bear downward with the heel of your right hand on his toes toward his buttock.

## LESSON 58

**How to Catch A Strangler**

If you are being strangled with a rope, handkerchief or anything similar the first thing to do, of course, is to ease the pressure on your throat.

Place the palms of both hands (fingers extended) under your assailant's elbows and force his elbows upward and inward. This will allow you to breathe by relaxing his hold.

Then quickly step off to your right and place your left foot behind your assailant's left foot—and place your buttock behind his buttock. Come into a position of balance (see lesson 1) and give your assailant a good buttock throw to the ground.

Without a moment's delay follow him and apply any powerful hold or lock you prefer.

## LESSON 59

**Handling a Strangler Who Attacks You From Behind**

While an assailant has a grip on your throat from behind bring up your thumbs and force them up between your neck and his little fingers.

Then grip his little fingers securely. This will be easy because a man has but very little strength in his smallest fingers.

Quickly straighten your arms out in line with your shoulders. This will break his grip—and his little fingers as well if you apply

some force backward.

As soon as you have broken his grip release your hold of his left little finger and pull his right arm over your right shoulder. This should be close up under his armpit. Then quickly bend both your knees.

Having gripped his right wrist with your left hand now, and his right upper arm with your right hand, you are in a position to throw him over your head.

Here's how to throw him best: Straighten your legs and bring the trunk of your body quickly forward and downward toward the ground. At the same time give a good downward pull on your assailant's arm.

These combined movements will send your man flying over your head quite a good way.

#### LESSON 60

### The Famous Double-Duty Powerful Leg Lock

Even the strongest man can be held down fairly easy by using the double leg lock on him. This is a ground hold where you find yourself on the ground with your assailant.

If both of you are still up throw your man down by using the flying dive (Lesson 22).

Then, like a flash, twist your man over flat on his stomach. Place his left leg to rest into the hock of his right leg.

Come up with his right leg and force the foot forward and downward toward his buttock. This will lock his foot between both parts (upper and lower) of his right leg.

He will call it quits when you bear downward with the heel of your right hand on the toes of his right foot toward his buttock.

#### LESSON 61

### Favorite Ju Jitsu Tricks

After you have mastered all the lessons in this course you will find yourself liking several of the holds better than the others. This is as it should be.

If 70 or 80 different possibilities come to mind at the instant you must act it is almost as bad as knowing no grips at all.

Master a few holds, know them 100%, and you will be able to act, when necessary, without running home for your lessons first.

Here are a few of the Ju Jitsu holds you have learned that are easy and quick—and they are holds that will fit many different situations.

A Sure-fire Knockout Blow	Lesson 5
Head Over Heels and He's Out	Lesson 26
Speedy Combined Arm and Leg Throw	Lesson 51

Super Flying Dive Attack  
Disarming the Hold-up Man  
Outlaw's Crucifixion

Lesson 22  
Lesson 36  
Lesson 44

You may have others in mind as being extremely effective. It makes no difference which you like best. For your own sake, though, please be sure, in any case, that you select about half a dozen and learn them perfectly.

#### LESSON 62

### How to Develop Your Arms and Improve Your Hand Grips

While sheer muscle is not essential in Ju Jitsu you should keep your fingers, wrists, elbows, shoulders—your whole arm and hand, in fact—supple and in tip top trim.

Your reaction-time should be quick, and without necessarily adding more muscle, your present muscular equipment must be in tingling sound condition.

Here is a short yet effective exercise designed to improve your grip:

With your upper arms and elbows close to your body make circular movements with the rest of your arm, from the elbow down. Keep your fingers straight out, but not stiff, and your thumb rather loose in the palm of your hand.

Make your circular movements outward, both forearms at once until your wrists are tired. Then reverse the circle doing it inward. About 5 minutes in each direction should make your arms start to ache which means the muscles and joints have had a good work-out.

Before the first day of this exercise take a measurement of your wrist and forearm. Then as your daily practice continues watch the improvement. You'll be surprised!

Here is another exercise; this one should develop the bicep muscles in your upper arms.

Start by standing erect with arms straight down full length at your sides. Extend fingers and thumbs, also.

Now keeping your elbows lightly to your side raise your left and right forearms alternately. As you do this movement clench and relax your fists to exercise the muscles in the forearm.

Do this about 5 minutes each day.

The following exercise is designed to develop your neck:

Stand erect with hands resting on your hips. Bring your chin forward as far as possible to your chest then raise your head upward and backward as far as possible. Like shaking your head "yes." Do this 10 times in each exercise period.

Next, still standing erect and without moving your feet or trunk, turn your head as far to the right as possible, then around to your left.

This will increase the size of your neck. But the chief purpose of this exercise is to strengthen the muscles and make them more instantly obedient to your will.

Now for exercise in chest development:

Standing erect with arms and fingers extended start your arms in circular movements from the shoulders—forward, upward, backward, and downward.

As you do this keep your mouth closed and breathe deeply through your nose. Take each deep breath with the upward sweep of your arms.

Then you exhale as your arms come backward and downward. Repeat 5 times daily.

Inhale in upward movement. Exhale with downward movement. This is excellent for lung and chest development.

#### LESSON 63

### Developing Tough Leg Muscles Through Special Resistance Exercises

Strengthening the legs and giving them split-second speed is not done by wearing yourself out with heavy weights. What you want are educated muscles—not brute ox-strength that moves slow and uncertain.

First get down in the sitting-squatting position explained in Lesson 2 on "The Secret of Breaking a Fall."

With your hands resting on your knees, which are turned outward, walk about 10 to 12 yards. Left, right, left, right. And as you advance each foot to step pull backward with the hand resting on that knee. In other words, restrain yourself as though trying to stop your legs from walking.

But use more forward force than resisting force so that you will go forward—with great exertion.

You will find it hard at first. Your leg muscles will ache before you have taken a dozen strides. Keep on if you can, though, and when you have walked your 10 to 12 yards raise your body upward to its full height on your toes only. Then sink down to allow your heels to rest on the ground.

After the second or third day try increasing the distance walked by 3 yards each day.

Besides leg development this exercise strengthens the sinews of your toes. Gives you more "spring" in your step. And it also gives you more poise and rhythm in your walk. In battle you should have the sudden-attack advantages of a panther!

The more your muscles ache in doing this strenuous exercise the more proof you have that the exercise is needed. Any soreness in the muscle will wear off in a few days and you will then be able to do the exercise with ease.

*If somebody else is doing your thinking, you are probably doing somebody else's work.*

*The wisdom of the wise is an uncommon degree of common sense.—Dean Wm. Ralph Inge*

*In all things, success depends upon previous preparation, and without such preparation there is sure to be failure.—Confucius*

### Capturing a Dangerous Criminal Unawares

#### LESSON 64

Plate 103

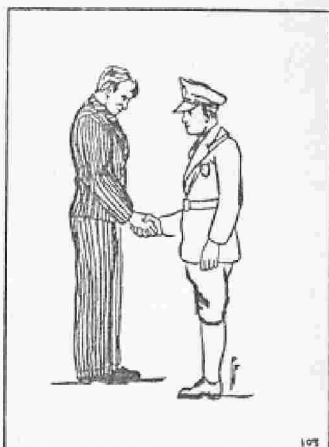

Before getting into this lesson let it be pointed out here that the rest of the lessons in this course are written especially for law enforcement officers. Policemen, wardens, guards and all other official attendants.

Many new holds and grips are introduced that, of course, will be valuable to laymen as well as officers. On the other hand some lessons discuss topics that are treated in detail elsewhere in this course. But this is not really a repetition because a new slant is given—a slant that points out special uses for officers.

There are two good reasons why an officer may have to capture a criminal by stealth. First, the officer may be unarmed or, at most, poorly armed in comparison with the desperado. Second, the encounter between gunman and policeman may take place in a busy street where gunfire must be avoided.



Plate 104

In meeting your man pretend you are not about to take him into custody. Rather, give him the impression you want to be



Plate 105

105

friendly. If possible talk to him, make him relax and shake hands with you. Plate 103 shows the starting position of this series of movements.

While shaking hands seize his wrist with your left hand above where your right hand holds his right hand. Swing his arm upwards as high as possible and make a complete right about turn as shown in the illustration numbered Plate 104.

Continue your movements until you come into the position as shown in Plate 105. You now have your prisoner in the "dislocation of the shoulder hold."

To handcuff your man place your right foot behind him—and apply a little leverage with your right forearm. This will force him down on his back where you can automatically come into the "wrist lock" for handcuffing.



Plate 106

106

Perhaps the first place a criminal will attack you with his bare hands is around your throat. In such a case do not move your neck until you have a hold on his arms—or you might wrench yourself into a bad injury.

Grasp the enemy's right wrist with your right hand and put the palm of your left hand under his elbow joint as shown in Plate 106.

Make a quick right turn and in one movement turn your head to the right and twist his wrist. Bear upward with a circular movement of your left hand at his elbow joint. Then advance your left foot in the same direction (to the right).

Continuing, bend your left leg at the knee forcing your man downward into the position as shown in Plate 107.



Plate 107

107

He must quit when you bear downward with your right hand on the knuckles of his right hand. At the same time force his forearm to the front.

This will break his wrist and dislocate his shoulder if his resistance is continued.

Now to lead your prisoner off to the lock-up force his forearm in front of yours, allowing your right hand to slide to his elbow joint as shown in Plate 108.

Then make him stand up straight and walk him to jail with this most effective arm hold. Plate 109.

He cannot strike or kick you. And should he even attempt to resist bear downward with your right hand at the elbow joint while you use your left arm as a fulcrum, forcing your left forearm upward and outward.

If something extra is needed try this.

From your position as in Plate 106 make a fast right about turn. At the same time wind the prisoner's arm around your waist close to your body.

Then jump forward and sit down. Resting your back against your man he will promptly go down to the ground on his face.

## Breaking Throat Grip And Capturing Strangler

### LESSON 65

By lifting his forearm upward and over to your left he will soon let you know he has had enough.



Plate 108



Plate 109



Plate 110

**How to Disarm a Gunman at Close Quarters**

**LESSON 65**

Facing a man with a gun in his right hand as illustrated in Plate 110., of course your first concern is not to get shot.

You can get out of the line of fire instantly by grasping his wrist with your right hand and placing your left also on his wrist just above your right hand.

While doing this—all in just a split-second—turn your own body half right and push the gun in the other direction, away from you. Illustrated in Plate 111.

Continuing this movement, raise his arm upward as high as possible—at the same time turn right about as shown in Plate 112. Keep right on turning until you come into the position shown in Plate 113.

You will make him drop his gun and give up the fight if you keep his arm bent as in Plate 113. His arm like the capital letter



Plate 111



Plate 112

L will cause him to lose his balance as you put on pressure, using your right forearm as a fulcrum.

In practice do this carefully and don't jerk the arm that is over your shoulder.



Plate 113



Plate 115

## Breaking Arm-Pinion Hold From Front



Plate 114



Plate 116

## LESSON 67

A criminal might try to throw you to the ground by clasping your entire body as shown in Plate 114.

As soon as you know his plan, raise your forearms and place your hands on the man's shoulders. Let them stay there.

Then in one movement bend your legs at the knees and force your arms outward as illustrated in Plate 115. This will relax the man's grip.

Quickly step behind him with your right foot so that your buttock comes exactly in the rear of his—and bend downward to your left front. Your man will be lifted off his feet and balanced on your buttock. Shown in Plate 116.

Following through you will throw the man flat on his back. Get him resting on his side and place your right knee on his ribs. Force his left arm against your left leg. Then put your right thumb close up under the lobe of his right ear. This is illustrated in Plate 117.

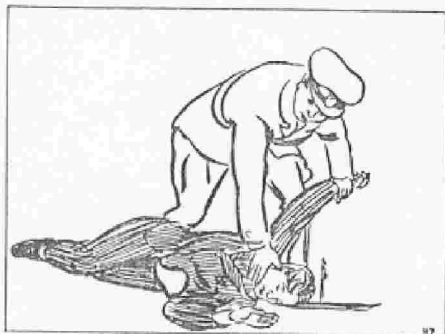

Plate 117

He is now in an extremely vulnerable position. A few blows with your knee will fracture his floating ribs. Bearing down on his wrist with your left hand will break his arm. Continued pressure with your thumb on his ear lobe nerve-center will cause him to lose consciousness.



In starting this counter-attack you may have to use a more severe method.

If your man is extremely large and strong and you are held in his "bear hug" too tightly to get your arms up use your knee. Deliver a brisk knee blow to the fork of his legs.

This will compel him to relax his grip and enable you to start your holds as already outlined.

## Rear Arm-Pinion Hold Release



Plate 118

### LESSON 68

This lesson treats a variation of the subject of Lesson 67. At the start your arms are held to your sides by a criminal standing behind you.

Do these two things together: Throw both arms straight out in line with both your feet. Your man's grip will be broken and you will come into position as shown in Plate 119.

Grasp his right wrist with your left hand and his upper arm with your right hand. See Plate 120. Make sure both your knees are turned outward as this plants you more firmly on the ground making it less likely you might lose your balance in the next move.

Now throw your man over your shoulder. Straighten your legs and bend your trunk downward toward the ground. These movements make it easy for you to get the man over your shoulder down to the ground in front of you.

Soon as he is over step backward a little with your left foot to keep your balance. Then get his hand in both your hands and place your knee on his arm at the elbow.

Force both your thumbs inward on the two nerve centers at the back of his hand, attempt to roll his hand up his arm, twist it outward as shown in Plate 5.

If his pressure is continued you will break his wrist. Striking his elbow with your knee will break his arm.

You might find it difficult to start these movements because of the unusually strong grip the criminal has around your arms and body.

In such an instance shoot your head back quickly and give



Plate 119



Plate 120

him a hard blow flush in the face with the back of your head. Another way is to stamp down hard on his toes with your heel.



Plate 121

121

Continued next issue

# SUPER Ju Jitsu

Copyright 1942

## Single Hand Belt Grip

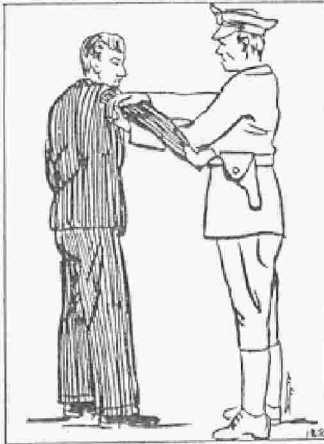

Plate 122

### LESSON 69

When your prisoner has gripped your service belt firmly with one of his hands bring your left hand up and under his right arm and lock fingers with your right hand. The correct spot to place your hands, shown in Plate 122, is midway between the elbow and the shoulder.

Then using both arms as a lever quickly bear upward with your left forearm and downward with your right arm. This combined movement will break his grip.

Now make a right turn and allow your right hand to slide along to his elbow joint. Result is the very effective police arm hold illustrated in Plate 123.

If your man becomes violent apply a little pressure on his shoulder by bearing downward with your hand at his elbow and upward with your left forearm. You know, of course, that this will dislocate his shoulder.

*I believe in work, hard work and long hours of work. Men do not break down from overwork, but from worry and dissipation.—Chas. Evans Hughes*

*Time is the one thing we possess. Our success depends upon the use of our time, and its by-product, the odd moment.—Arthur Brisbane.*

*There is no feeling in this world to be compared with self-reliance—do not sacrifice that to anything else.—John D. Rockefeller*

*A man who trims himself to suit everybody will soon whittle himself away.*



Plate 123

To handcuff your man while he continues to give you trouble trip him with your left foot. He will go down on his face and you can then easily snap the bracelets on his wrists.

## Two Hand Belt Hold



Plate 124

### LESSON 70

It is easier to break the man away from you while he holds your belt with two hands than was the case in lesson 69 where he held with only one hand.

With your left hand seize him by his belt or the top of his pants. At the same time bring up your right hand and deliver a blow with the heel (fingers extended) under his chin.

Turn left and get your right leg between his legs so he cannot kick you in the scrotum. Position illustrated in Plate 124.

A forceful blow to his chin will push his neck back and give him a very severe jolt. So much so that he will relax his grip on your belt.

Next you handcuff him or apply the arm hold.

## Breaking Grip From Behind

LESSON 71

Plate 125



When a person is violent he frequently clings to any secure object within his reach to prevent you from leading him off under arrest.

It is easy to get behind the man and force him to release his grip.

Place your left forearm across his throat, extend the fingers of your right hand and bring it up with force under the cartilage of his nose. This will force his head back as shown in Plate 125 and break his grip.

Then grasp your own left wrist with your right hand and turn right about so that you come back to back. Walk forward. Your man will be dragged backward in an unbalanced position as shown in Plate 126.

Handcuff him whenever convenient.



Plate 126



Plate 127

LESSON 72

## How to Capture Two Armed Assailants Who are Attacking You

Speed is always important in Ju Jitsu but never more so than when you have two men to take care of at the same time.

In this instance assume you are set upon by two thugs armed with knives, clubs or similar weapons.

Extend the fingers of your right hand and deliver a chopping blow midway on the jaw of the first assailant. Strike with the hand's edge, and strike forcefully. Plate 127. Number One attacker will drop.

If you are by now just about to be clubbed by attacker number 2 parry the blow with your right forearm. Bring up your left hand and seize his arm at the elbow as shown in Plate 128.

Turn right, force his arm downward into the position illustrated in Plate 129—and at the same time advance your left foot



Plate 128

and bend your leg at the knee so that the trunk of the man's body will rest on your leg.

Then bring his arm around into the position as shown in the illustration Plate 129, and keep his arm bent around you like

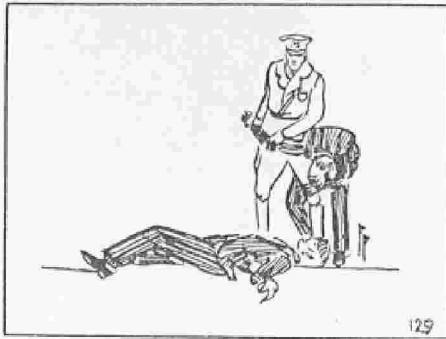

Plate 129

capital letter L. He will quit and drop his weapon, if he is wise.

If not, bear downward with the palm of your right hand on the knuckles of his hand and at the same time force his forearm forward to your front. Result: broken wrist and dislocated shoulder.

Handcuff the men together.

### Special Arm Twist and Wrist Lock



Plate 130

#### LESSON 73

Face your man and seize his right wrist with your left hand. Immediately lift his arm up sideways as high as possible.

With your right hand grip his elbow joint, placing your thumb in the bend of his arm as illustrated in Plate 130.

Now turn left about and face the same direction as your man. In turning slide your left hand over the knuckles of his hand so they come into the palm of your hand.

Duck your head under his arm in turning about as shown in Plate 131.

Continue your movements and place his hand, along with your hand, close up under his armpit. Get his elbow up tightly under your armpit. Plate 132 illustrates the position you now find yourself in.



Plate 131

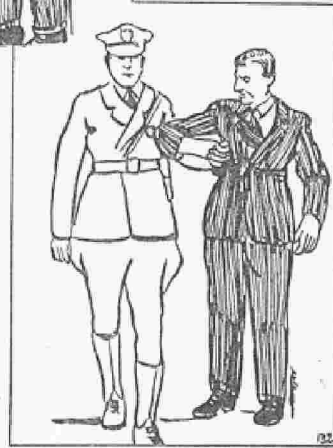

Plate 132

Your prisoner is now held in an escape-proof wrist hold. He will break his wrist if he attempts to get away.

In fact, you have him tied up so nicely that he will hurt himself if he even turns to strike you. Any sudden turn will snap his wrist.

You can apply just enough pressure to make him obedient.

*Good intentions, like eggs, unless they be hatched into action, will run into rottenness.—Samuel Smiles*

*Men, like bullets, go farthest when they are smoothest.—Jean Paul Richter*

*Youth is not a time of life; it is a state of mind.—Samuel Ullman*

*Killing time is not murder.—It's suicide.*

*A journey of a thousand miles begins with one step.—Chinese Proverb*

## The "Come Along" Hold for Policemen



Plate 132

### LESSON 74

This is really a combination arm and wrist hold with throw. It is used to walk a man to the police station or elsewhere to be held, to simply hold securely a roughneck, or to get him into position for handcuffing.

Secure his right wrist with your right hand and grip his upper arm with your left hand as shown in Plate 132.

Make a quick left about turn and at the same time allow your left hand to grip your own right forearm.

Put your right leg behind his right leg and force your man down on his back by using your left forearm as a fulcrum. See illustration Plate 134.

The moment your man hits the ground you can automatically come into a wrist hold that will allow you to handcuff him. Should he still resist just bear downward on his knuckles with your right hand. This makes him stop his fighting.



Plate 135

## Quickest Way Of Making Your Attacker Absolutely Powerless



Plate 136

### LESSON 75

Double Reverse Arm Hold and Throw is the technical name for the operations explained in this lesson.

Again you face your man and seize his right wrist with your right hand. This movement brings your left hand on top as shown in Plate 136.

Now snap left about and in so doing cross your man's arms. Pull him toward you.

Allow both his crossed arms to rest on your right shoulder. At the same time bend both your legs slightly at the knees. Illustrated in Plate 137.

Stand erect—make yourself as tall as possible—and pull downward with both your hands at the wrists.

If you yank with a jerking movement you will break both his arms.



Plate 134



Plate 137

Ordinary leverage, however, will raise your man up on his toes without breaking any bones. In this position he will not have much fight left.

To throw your man you come up a bit differently. Straighten out your legs as before but while doing this bend your whole trunk forward and downward. Pull both his arms across your body to your left.

He will shoot right over your shoulder and flat on his back in a sprawling position.

*All wish to possess knowledge, but few, comparatively speaking, are willing to pay the price.—Juvenal*

Popular Mechanics  
June 1902

Harper's Weekly June 20, 1857

#### 700 CRIMINALS IN A WOMAN'S DESCENDANTS.

What one criminal can do toward making the world more wicked is shown in statistics presented at the annual convention of the New York county W. C. T. U. A delegate gave the record of the family of one woman of criminal tendencies who died in 1827. The speaker said:

"This woman's descendants have been traced. They number 800. Seven hundred were criminals, having been convicted at least once. Thirty-seven were murderers and were executed for their crimes. This family has cost the nation \$3,000,000 for trials and executions."

Popular Mechanics Dec., 1902

#### REMEDY FOR VITRIOL BURNS.

A Frenchman has discovered a remedy instantaneous in its effects for the horrible burns caused by the use of oil of vitriol. It is soft paste of calcined magnesia and water, with which the parts burned are covered to the thickness of an inch. It alleviates the pain almost immediately, and when the paste is removed no scar remains.

Oil of Vitriol=Sulphuric Acid  
Calcined Magnesia=Magnesium Oxide

#### WHEN TO KILL YOUR MAN.

A case has just been decided by the Court of Appeals at Frankfort, Kentucky, which settles the question as to when a man who is attacked in the State of Kentucky is justified in killing his assailant. The case was from Grayson Circuit, in which Meredith had been convicted of manslaughter for the killing of one Ireland who attacked him, and the lower Court charged the Jury:

"If Ireland assaulted the defendant, and he had reasonable grounds to believe he was in danger of sustaining great bodily harm, or the loss of life from such assault, and if necessary, to protect his life or person from great bodily harm, he might kill Ireland, if he had no safe means of escaping. But if the defendant could have safely retreated from the danger, and by that means have saved his life and person, he is not excusable for the killing of Ireland."

The higher Court, however, decided that this was wrong. The Jury had nothing to do with the question, whether "the defendant could have safely retreated," that being a question to be settled by the judgment of the defendant himself. "In the exercise of this judgment he must act rationally. Whether an actual necessity to kill existed or not was a question to be decided by Meredith at the time. Though he may have erred in his judgment, though he 'could have safely retreated,' yet if he acted in good faith, and had reasonable grounds to believe that his only safety was to kill his antagonist, the law excuses him."

Scientific American  
Sept. 1845

**INCREASE OF CRIME.**—During the last forty years, commitments for crime have increased from 3,000 to 31,000 per annum, in England, although the population has increased only about sixty per cent. during the same period.



## U. S. RIFLE .30 M1 (.30-06) GARAND

There is usually some confusion between the M1 Garand and the M1 Carbine because the military called both cartridges ".30 caliber". They won't use the designation .30-06 as

the rest of the world does. So  
 .30 M1 Garand = .30-06  
 .30 Carbine = .30 Carbine  
 They call the later developed .308 cartridge by its NATO 7.62 mm.

### Disassembly and Assembly

**DESCRIPTION OF THE RIFLE.** The U. S. Rifle Caliber .30 M1 is a gas-operated, clip-fed, air-cooled, semiautomatic (self-feeding) shoulder weapon (Plate 2). It weighs approximately 9.5 lbs. The bayonet weighs an additional pound. Ammunition is issued, generally, in an expendable clip which holds 8 rounds. The M1 is noted for its rapid mechanical operation, which enables the individual rifleman or a group of riflemen to deliver a large volume of accurate fire upon any designated point or area within range.

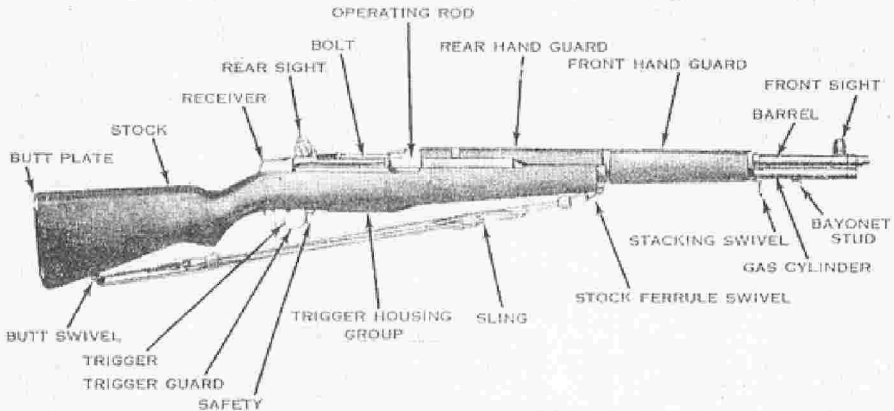

The weapon is composed of three main groups: The trigger housing group, barrel and receiver group, and the stock group.

**DISASSEMBLY.** The trained soldier is permitted to disassemble only certain parts of any weapon, not because the disassembly of some of the parts is beyond his ability to learn, but because constant disassembly tends to cause undue wear, and the disassembly of some parts (separation of accelerator from operating rod catch assembly) is difficult without suitable equipment.

The individual trained soldier is permitted to:

- (1) Dismount the three main groups.
- (2) Disassemble the barrel and receiver group to include:
  - (a) Removal of follower rod and operating rod spring.
  - (b) Removal of follower arm pin.
  - (c) Removal of bullet guide, follower arm, and operating rod catch assembly.
  - (d) Removal of follower assembly.
  - (e) Removal of operating rod.
  - (f) Removal of bolt assembly.
- (3) Disassemble the bolt assembly to include:
  - (a) Removal of extractor.
  - (b) Removal of extractor spring and plunger.
  - (c) Removal of ejector and ejector spring.
  - (d) Removal of firing pin.
- (4) Remove the gas cylinder lock screw.

## HOW THE U. S. RIFLE M-1 WORKS

Starting with the rifle loaded and cocked the action is as follows: The trigger being pressed, the hammer strikes the firing pin, exploding the cartridge in the chamber. As the bullet passes over the gas port drilled in the under side of the barrel, some of the gas escapes into the cylinder and blasts back against the piston and operating rod with force enough to drive the rod to the rear and compress the return spring.

During the first 5/16" of rearward travel the operating lug slides in a straight section of the recess on the operating rod; after which the cam surface of this recess is brought in contact with the operating lug which it cams up, thereby rotating the bolt from right to left to unlock its two lugs from their recesses in the receiver.

During the moment of delayed action, the bullet leaves the barrel and the breech pressure drops to a safe point. The further rotation of the bolt then cams the hammer away from the firing pin and pulls the firing pin back from the bolt. The operating rod continues its backward movement carrying the bolt with it as the lug on the bolt has reached the end of its recess.

During this rearward motion of the bolt, the empty case is withdrawn from the chamber by the extractor positioned in the bolt until it is clear of the breech; at which point the ejector, exerting a steady pressure on the base of the cartridge case, throws it to the right front by the action of its compressed spring.

The rear end of the bolt at this point forces the hammer back, rides over it and compresses the hammer spring; and finally stops in the rear end of the receiver.

As the bolt has now cleared the clip, the follower

spring forces the cartridge up until the topmost one is in line with the bolt.

The operating rod spring comes into play at this point to pull the action forward.

**Forward Movement of the Action:** As the bolt moves forward, its lower front base strikes the base of the cartridge case and pushes it into the firing chamber. The hammer, pressed by its spring, rides on the bottom of the bolt. While it tends to rise, it is caught and held by the trigger lugs engaging the hammer hook, if trigger pressure has not been released. Otherwise the trigger engages the rear hammer hook until letting go the trigger disengages the sear from the hammer. The hammer then slides into engagement with the trigger lugs.

When the bolt nears its forward position, the extractor engages near the rim of the cartridge and the base of the cartridge forces the ejector into the bolt, compressing the ejector spring.

The rear surface of the cam recess in the operating rod, now cams the operating lug down and thereby twists the bolt from left to right until the two lugs lock into their places in the receiver.

The operating rod drives ahead for another 5/16". The rear end of the straight section of the operating rod recess reaches the operating lug on the bolt, which completes the forward movement and leaves the rifle ready to fire when the trigger is pressed.

This cycle continues as long as there are any cartridges in the magazine and the trigger is squeezed.

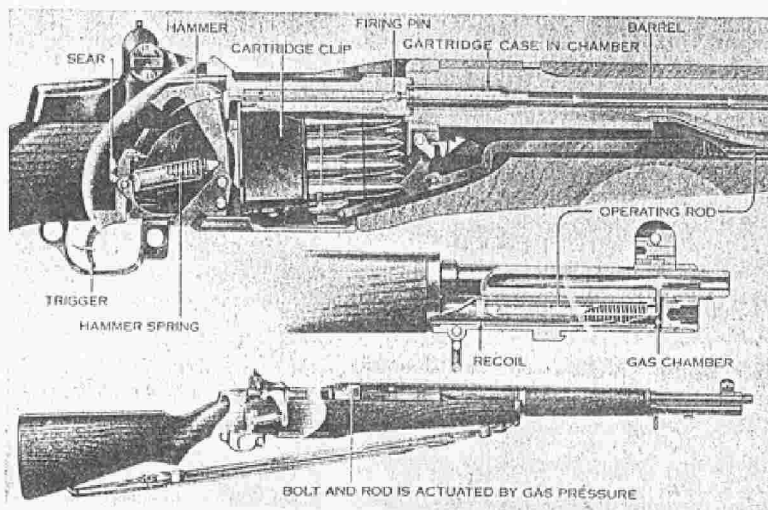

Basic Functioning of the Garand



PLATE 4.  
REMOVING  
TRIGGER  
HOUSING  
GROUP



**FIELD STRIPPING.** The steps outlined above are commonly referred to as "field stripping" since they can be accomplished with the equipment usually carried in battle by the individual soldier. Rifles are disassembled and assembled without the application of force when correct methods are employed. Every rifleman must understand thoroughly the steps presented below, and must be able to accomplish them in darkness.

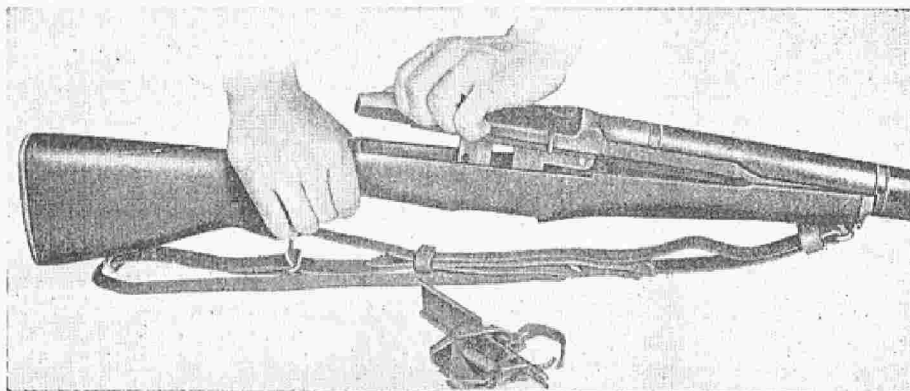

PLATE 5. SEPARATING STOCK GROUP FROM BARREL AND RECEIVER GROUP

**METHODS OF DISASSEMBLY.** Three main groups. (1) (Plate 4.) Grasp rifle with left hand so that base of trigger housing is included in grip of fingers. Place butt of rifle against left thigh. Grasp rear portion of trigger guard with thumb and forefinger of right hand and exert sufficient pressure downward and outward to unlatch trigger guard from trigger housing. Then swing trigger guard away from trigger housing to extreme opened position. Pull out trigger housing group. Place this group on a smooth clean surface.

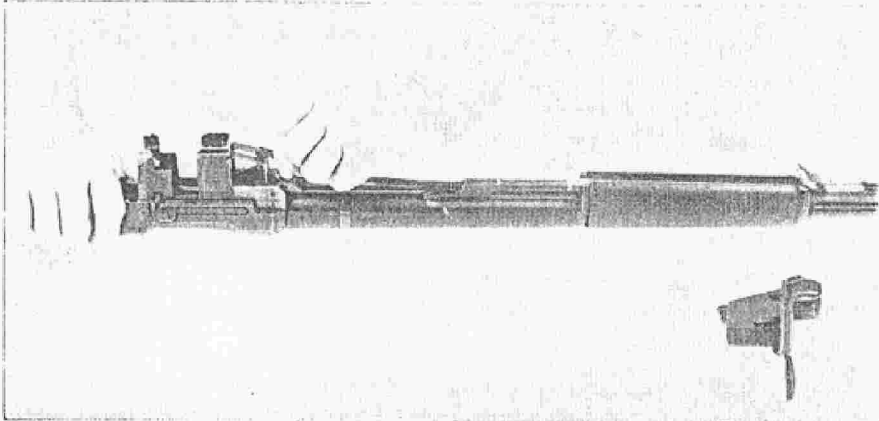

PLATE 6. DISENGAGING FOLLOWER ROD

(2) (Plate 5.) Grasp rifle over rear of the receiver with left hand, muzzle to left. Strike and grasp small of stock with right hand so as to separate stock group from barrel and receiver group.

**Barrel and receiver group.** (1) (Plate 6.) Place group on a smooth surface, sights down and muzzle to the left. Grasp follower rod with left thumb and forefinger and disengage it from the follower arm by pressure toward the muzzle. Withdraw follower rod and operating rod spring to the right. Do not separate these parts.

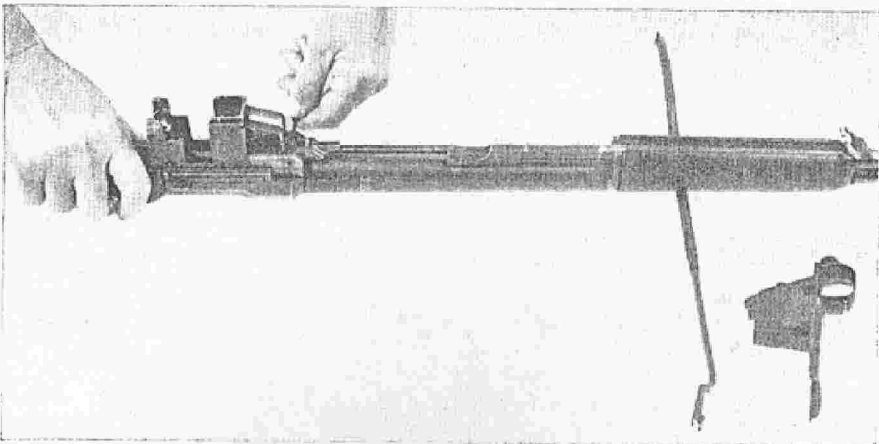

PLATE 7. REMOVING FOLLOWER ARM PIN

(2) (Plate 7.) Push follower arm pin from its seat by starting it with the point of a bullet (or with drift of combination tool) held in right hand and applied on side of receiver farthest from body. Pull out pin from near side with left hand.

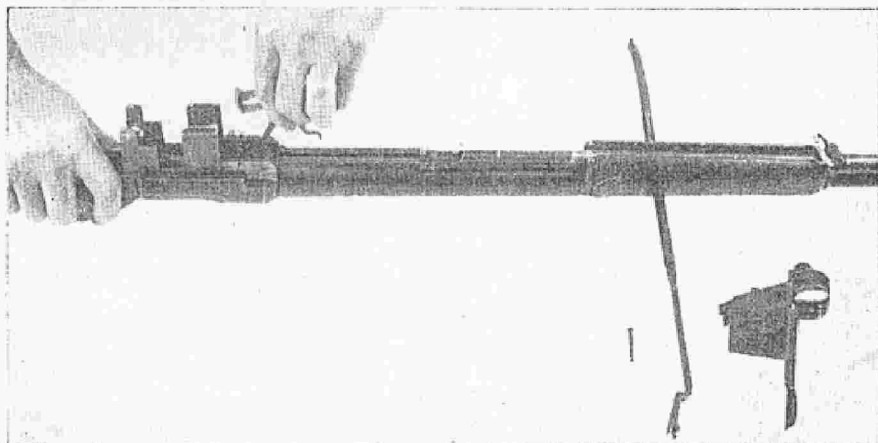

PLATE 8. DISENGAGING BULLET GUIDE, FOLLOWER ARM, AND OPERATING ROD CATCH ASSEMBLY

(3) (Plate 8.) Grasp bullet guide, follower arm, and operating rod catch assembly and pull to the left until these parts are disengaged. Lift out and separate these three parts. Do not remove accelerator from operating rod catch assembly since accelerator pin is riveted in its seat.

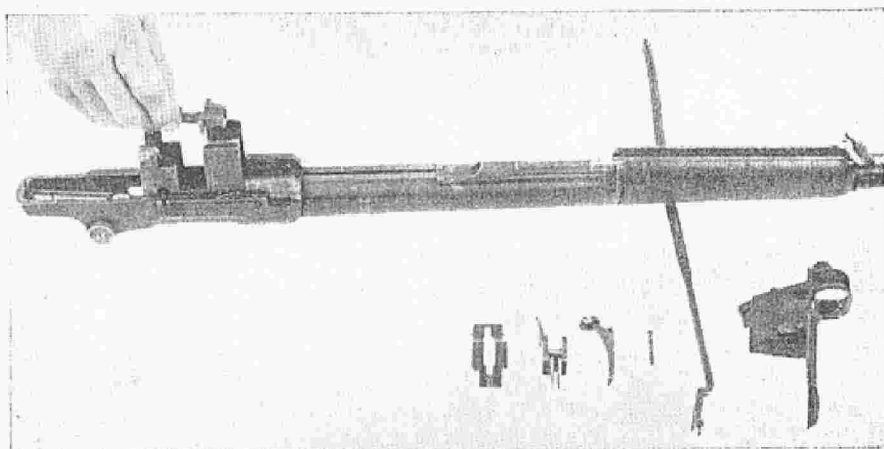

PLATE 9. LIFTING OUT FOLLOWER

(4) (Plate 9.) Lift out follower assembly. Do not separate follower from follower slide.

(5) Turn the barrel and receiver group over so that the sights are up, muzzle pointing away from you. With the left hand, raise the rear of the group. With the right hand, pull the operating rod to the rear until the rear of the handle is directly under

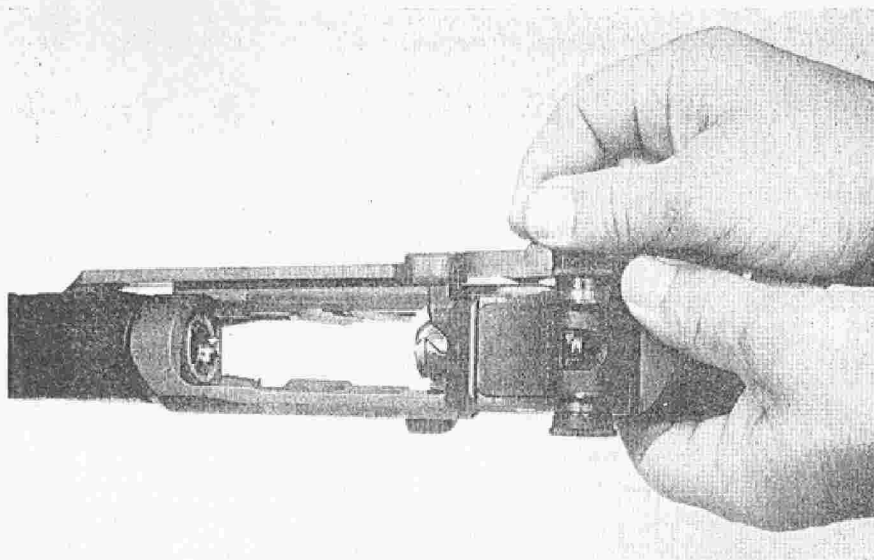

PLATE 10. REMOVING OPERATING ROD

the forward edge of the windage knob. Grasp the handle with the thumb and fore-finger of the right hand; and with an upward and outward pressure, disengage the guide lug of the operating rod through its dismount notch on the receiver. Remove the operating rod (Plate 10).

NOTE: The operating rod has been bent intentionally. Do not attempt to straighten it.

(6) (Plate 11, Figure 1.) Grasp bolt by operating lug and while sliding it from rear to front, lift it up and out to the right front with a slight rotary motion.

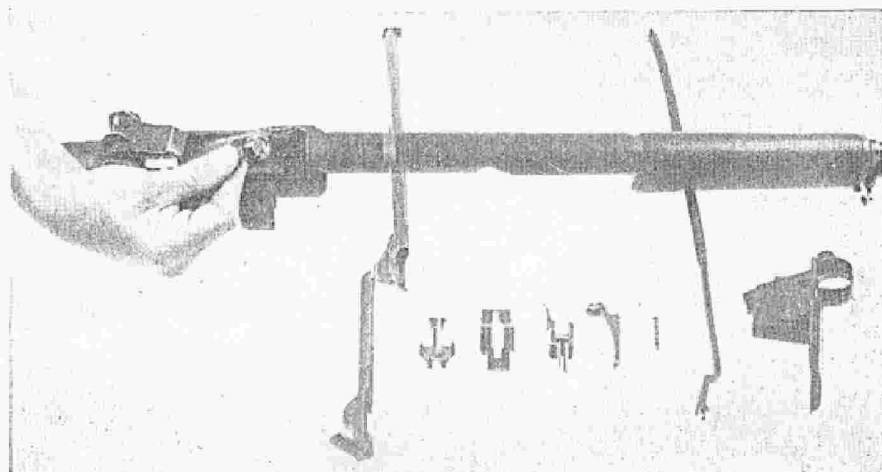

Figure 1. Removing Bolt  
PLATE II. DISASSEMBLY OF BOLT



**Bolt assembly. (1)** (Plate 11, Figure 2.) Grasp the bolt in the left hand, face of bolt up, and operating lug to left. Place the little finger under the tang of the firing pin, and the left thumb over the compressed ejector and the spring to prevent it from flying out. Insert the screwdriver blade between the extractor and the lower cartridge seat flange, and pry out until the ejector snaps up against the left thumb. Release the thumb-pressure on the ejector slowly.

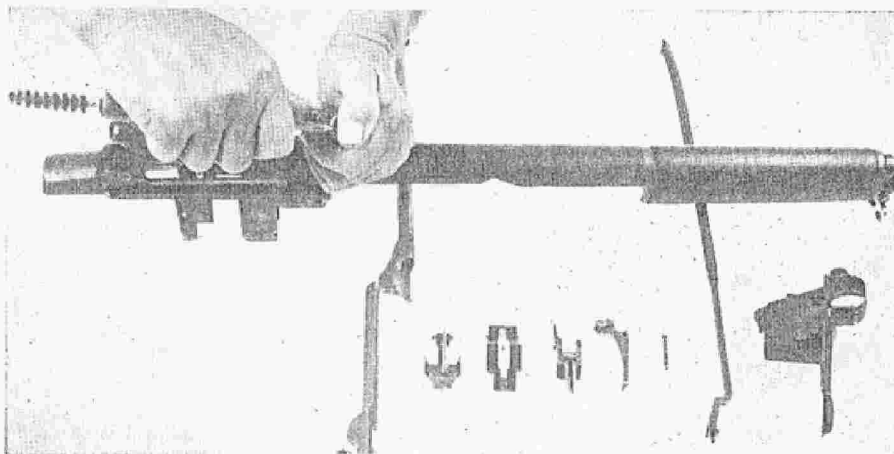

Figure 2. Releasing Ejector

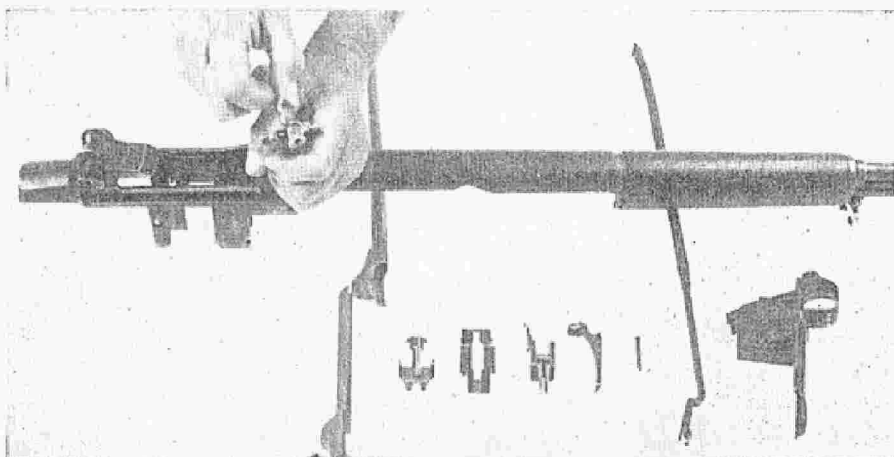

Figure 3. Removing Extractor  
PLATE II. DISASSEMBLY OF BOLT (Continued)

- (2) (Plate 11, Figure 3.) Remove the extractor.
- (3) (Plate 11, Figure 4.) Tap the bolt gently until the extractor spring and plunger are unseated. Remove both parts, but do not separate.
- (4) (Plate 11, Figure 5.) Remove ejector and attached ejector spring. Do not separate.

(5) (Plate 11, Figure 6.) Lift the bolt up slowly and the firing pin will fall out. Remove it from the rear of the bolt.

**Gas cylinder lock screw.** (Plate 12.) Using the screw driver blade, unscrew and remove the gas cylinder lock screw only. If under supervision of noncommissioned officer, unscrew and remove the gas cylinder lock.

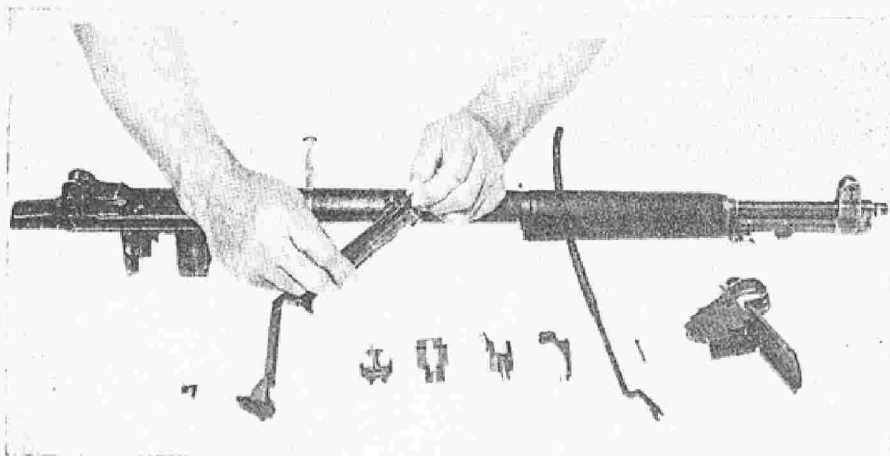

Figure 4. Removing Extractor Spring and Plunger

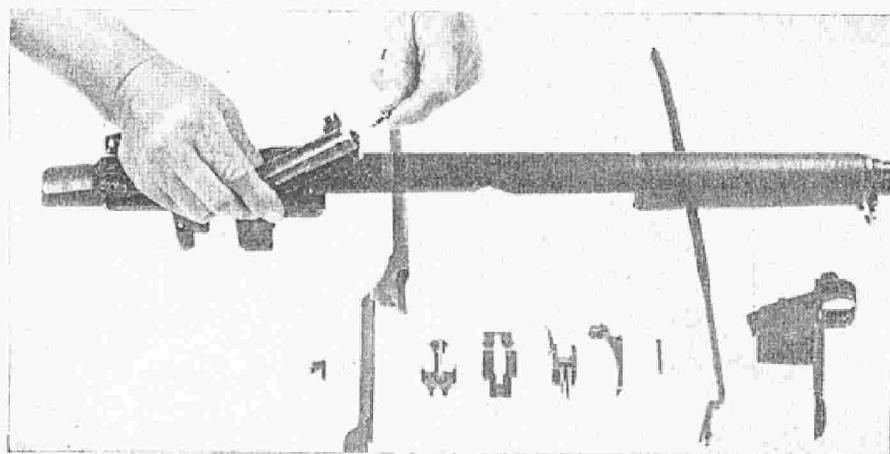

Figure 5. Removing Ejector and Ejector Spring  
PLATE 11. DISASSEMBLY OF BOLT (Continued)

**Clip latch.** The clip latch may be disassembled only under the supervision of a non-commissioned officer. To disassemble it, place the receiver on its right side with the muzzle pointing to the left. With the thumb of the left hand, depress the clip latch. This relieves the tension of the clip latch spring. Using the point of a bullet or the drift of the combination tool, push forward on the clip latch pin and unseat it. Remove

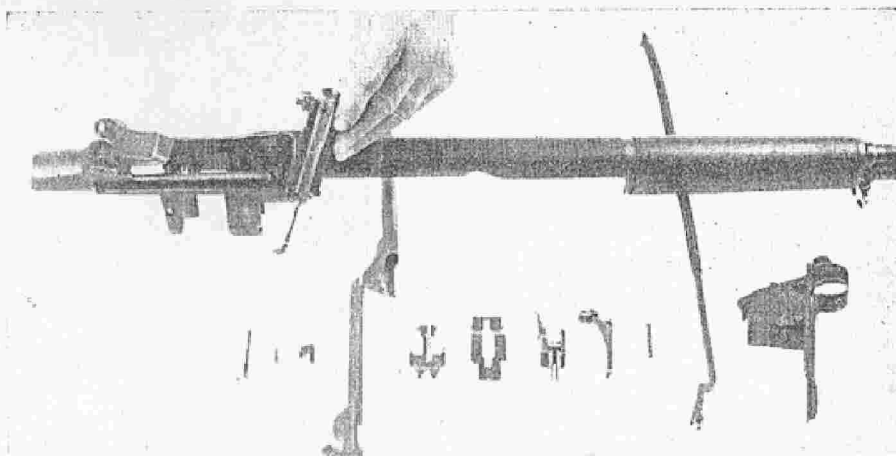

Figure 6. Removing Firing Pin  
 PLATE 11. DISASSEMBLY OF BOLT (Continued)

it by withdrawing it with the finger tips. Lift out the clip with the clip latch spring attached.

Trigger housing group. The trigger housing group may be disassembled only under the supervision of a noncommissioned officer. To disassemble it, close and latch the

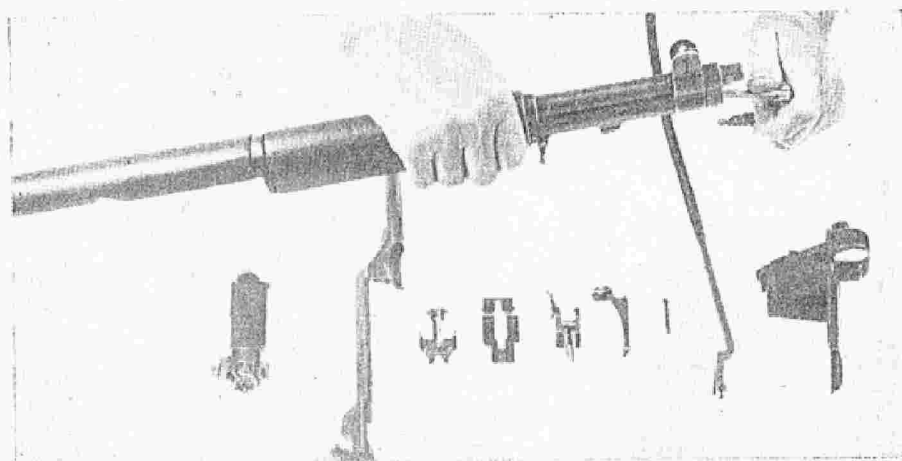

PLATE 12. REMOVING GAS CYLINDER LOCK SCREW

trigger guard. Squeeze the trigger, allowing the hammer to go forward. Hold the trigger housing group with the first finger of the right hand on the trigger and the thumb against the sear. Place the front of the trigger housing against a firm surface. Squeeze the trigger with your finger and push forward on the sear with the thumb. At the same time, using the drift of the combination tool or the tip of a dummy car-

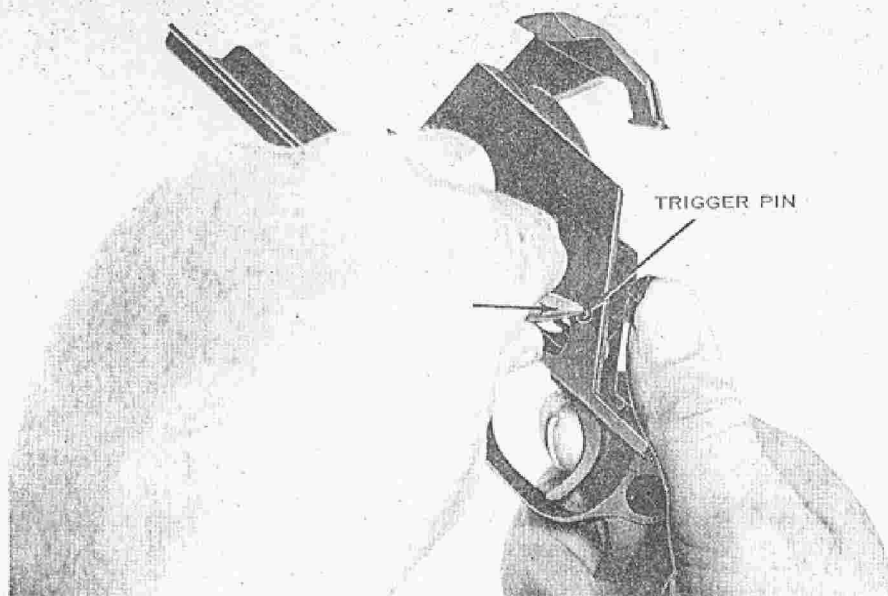

PLATE 13. REMOVING THE TRIGGER PIN

tridge, push out the trigger pin from left to right (Plate 13). Slowly release the pressure with your finger and thumb. This allows the hammer spring to expand.

Lift out the trigger assembly. Remove and separate the hammer spring plunger, hammer spring, and the hammer spring housing (Plate 14).

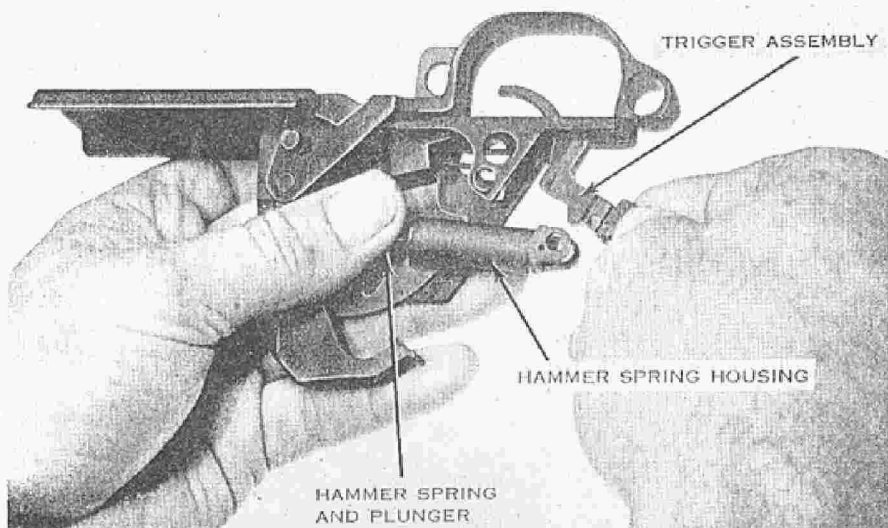

PLATE 14. REMOVING THE TRIGGER ASSEMBLY, HAMMER SPRING HOUSING, HAMMER SPRING, AND HAMMER SPRING PLUNGER

Continued next issue

## M-1 30-06 GARAND

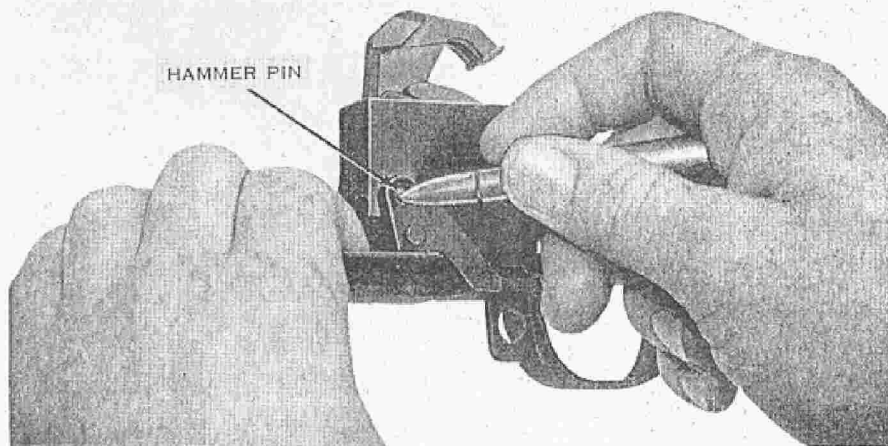

PLATE 15. REMOVING THE HAMMER PIN AND HAMMER

Using the combination tool or a dummy round, push out the hammer pin from left to right. Move the hammer a little to the rear and lift it out (Plate 15).

Unlatch the trigger guard. Lay the trigger housing on its right side. With the drift of the combination tool or the point of a bullet, push out the stud of the safety from its hole. Remove the safety by lifting it from its slot in the base of the trigger housing (Plate 16).

Hold the rear of the trigger housing with your left hand and the trigger guard with your right hand. Swing the trigger guard down into the opened position. Slide the



PLATE 16. UNSEATING THE SAFETY

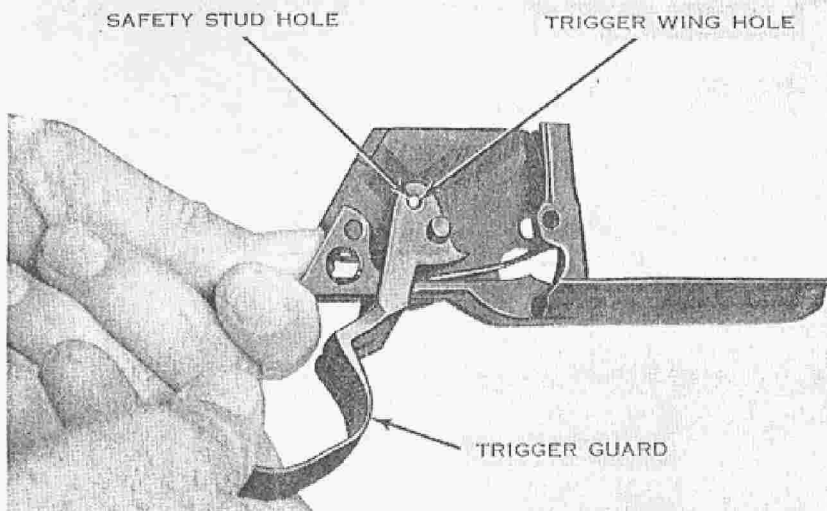

PLATE 17. REMOVING THE TRIGGER GUARD

trigger guard to the rear until the wings of the trigger guard are alined with safety stud hole. Rotate the trigger guard to the right and upward with your right hand until the hammer stop inside of the right wing clears the base of the trigger housing. Remove the trigger guard (Plate 17).

Lay the trigger housing on its right side. Insert the point of a bullet or the screw

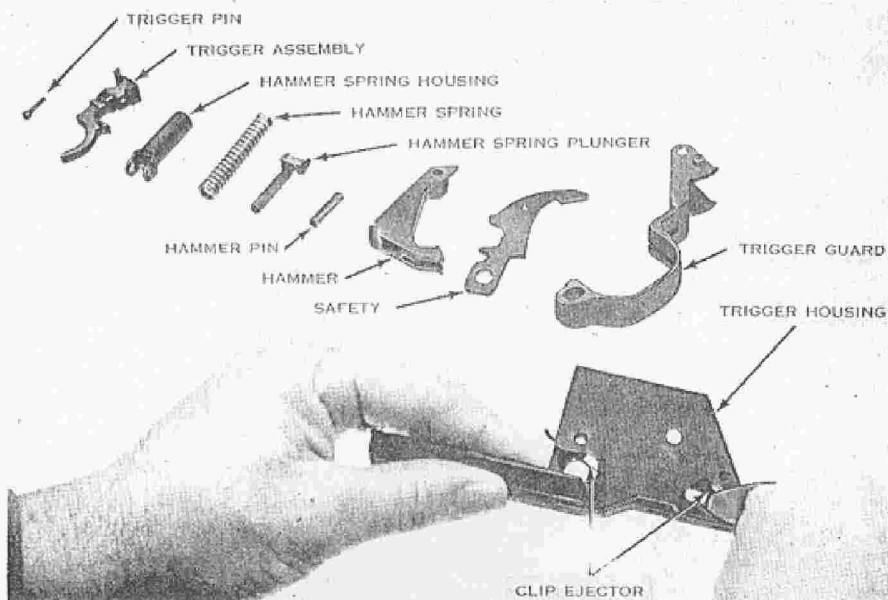

PLATE 18. REMOVING THE CLIP EJECTOR

driver blade of the combination tool in the hole by the loop of the clip ejector. Push downward on the clip ejector and unseat it (Plate 18).

**ASSEMBLY. General.** The rifle and its component parts are assembled in the reverse order of their disassembly.

**Trigger housing group.** Hold the trigger housing in your right hand, with the left side down and the rear end to the right. Place the clip ejector in position in the trigger housing with the short arm toward your body and the tip of the long arm in its slot in front of the trigger housing. The loop of the clip ejector is positioned on top of its stud on the left side of the trigger housing. With your right thumb, hold the loop of the clip ejector on top of this stud. With the forefinger of your left hand, hold the long arm up in its slot on the front of the trigger housing. Place the tip of your left thumb between the long arm and the base of the trigger housing and move the long arm toward your body, at the same time exerting pressure downward. The long arm of the clip ejector will snap into the notch on the base of the trigger housing (Plate 19).

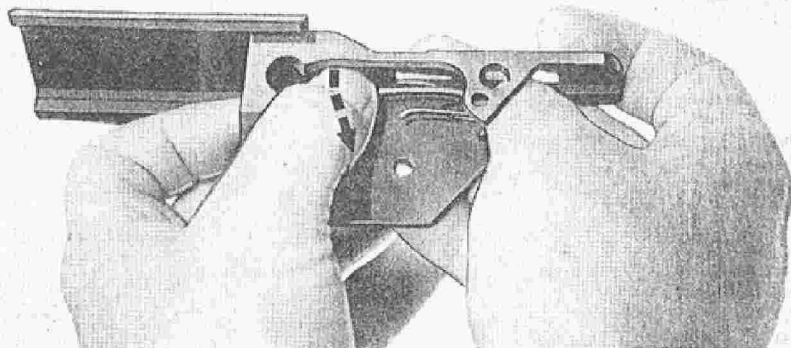

PLATE 19. REPLACING THE CLIP EJECTOR

To replace the trigger guard, hold the trigger housing as shown in Plate 17. Place the wings of the trigger guard astride the base of the trigger housing so that the hammer stop, on the inside of the right wing, clears the base. Turn the trigger guard down and to the left until the holes in the wings are under the safety stud hole. Slide the trigger guard forward until the holes in the wings are aligned with the hammer pin hole.

Insert the finger piece of the safety through its slot in the base of the trigger housing. To reseat the safety stud in its hole in the trigger housing, force the safety down against the pressure of the short arm of the clip ejector. Push the finger piece of the safety forward.

Insert the hammer loosely in position, holding it halfway between the cocked and fired position. Be sure that the hammer toe clears the hammer stop on the right wing of the trigger guard. Aline the hammer pin holes in the hammer with the holes in the trigger housing and trigger guard. Be sure that the trigger guard is not latched. Insert the hammer pin from the right side. Move the hammer to the fired position. Close and latch the trigger guard.

Place the trigger housing group on the table with the base down and the rear end to the right. Assemble the hammer spring housing, hammer spring, and hammer spring plunger into one unit. Place the plunger in its seat on the hammer. Make sure that the open side of the hammer spring housing is toward the safety. (This is important



because failure to do this prevents the safety from being used; also the sear will not function.) Hold these assembled parts in a raised position with the thumb and fingers of your left hand. With your right hand, insert the trigger into the trigger slot so that the notch at the curved rear surface of the finger piece bears against the rear of the slot in the trigger housing. Place the wings of the hammer spring housing astride the sear pin. With your right forefinger on the trigger and the right thumb against the sear, apply pressure forward against the sear and at the same time squeeze the trigger. Hold the parts in this position and insert the trigger pin as far as its head only (Plate 20).

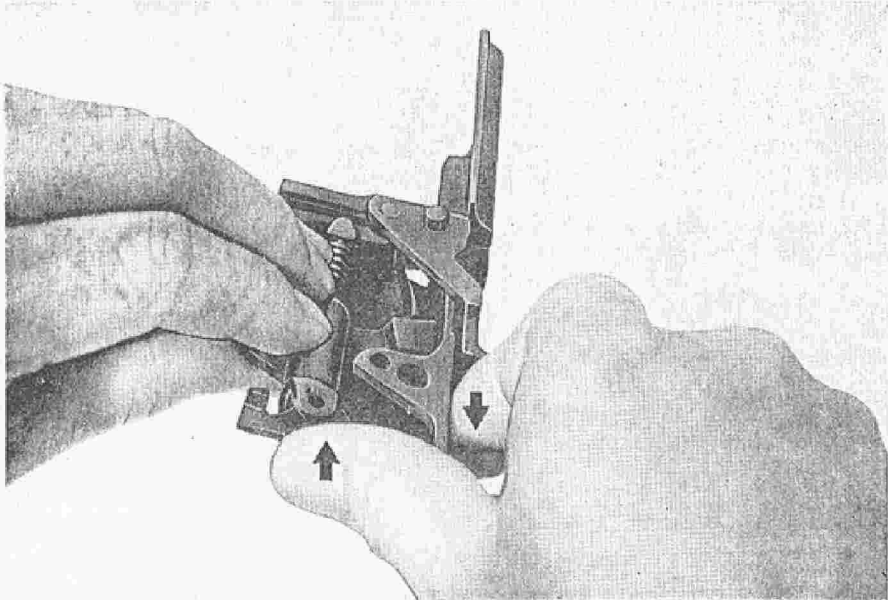

PLATE 20. REPLACEMENT OF THE TRIGGER ASSEMBLY, HAMMER SPRING HOUSING, HAMMER SPRING, AND HAMMER SPRING PLUNGER

To seat the head of the trigger pin, hold the trigger housing group as shown in Plate 21. Note the direction the pin must be moved to be seated. By applying pressure with the thumb and fingers, align the head of the trigger pin with the trigger pin holes. Seat the trigger pin by pressing on its head with the left thumb.

**Clip latch.** Place the clip latch with the clip latch spring attached in position on the left side of the receiver and start replacing the clip latch pin from the front. Press in on the thumb piece of the clip latch to relieve the tension of the clip latch spring, and push the clip latch pin fully home. If the pin head is not fully seated, it will damage the stock.

**Gas cylinder lock screw.** Engage the threads of the gas cylinder lock with those on the barrel and screw it on by hand until it is finger tight. If the lock is not alined with the gas cylinder, do not force it, but unscrew it until it is alined. Replace the gas cylinder lock screw and tighten it securely.

**Bolt assembly.** Insert firing pin into bolt, making sure that tang enters slot in rear of bolt. Grasp bolt in left hand (face up, operating lug to right) and hold firing pin in place with little finger. Insert ejector with ejector spring attached, spring down,

so that cut on ejector is toward the right. Insert extractor spring and plunger, spring down. Set stud of extractor into its hole in bolt. Compress extractor spring and plunger; press slightly on extractor until it just begins to ride over extractor plunger. Place drift of combination tool in left groove of bolt with ejector in the V-shaped groove cut into face of tool. With the right thumb near drift end of the handle on the combination tool, press down on tool so as to depress ejector below level of cartridge seat flange; with thumb of left hand push extractor in until extractor plunger is seated. Ejector and ejector spring can also be compressed with the base of a dummy cartridge or, when in the field, with the base of a live round. (When a live round is used,

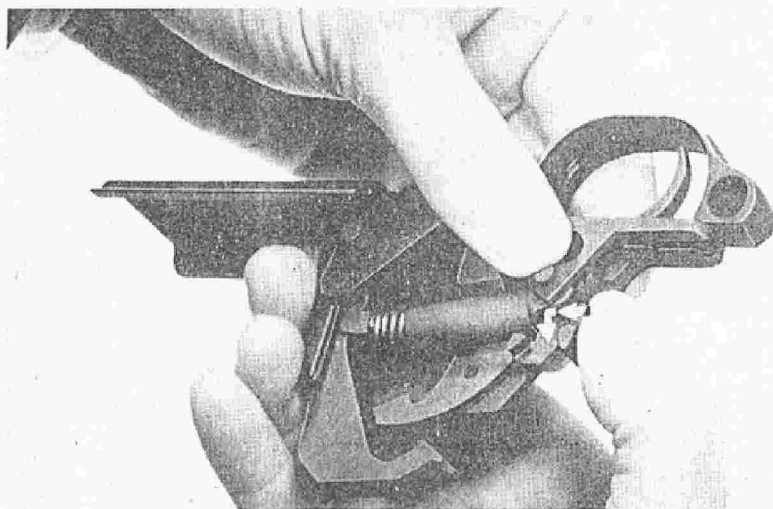

PLATE 21. SEATING THE TRIGGER PIN

care must be taken not to ignite the primer.) The chamber cleaning portion of the combination tool may also be similarly used. In any case, the ejector must be depressed until its top is *below* the level of the cartridge seat flange. In using a cartridge or a chamber cleaning tool, they must be so placed as to slide down inside inner curved surface of flange. Press ejector with the edge of base of a cartridge (or chamber cleaning portion of combination tool).

**Barrel and receiver group.** (1) Place barrel and receiver group on a table or other flat surface, with the sights up, and the muzzle pointing to the left. Hold the bolt by its operating lug so that the front end (face) of the bolt is slightly above and to the right of its extreme forward position in the receiver. Insert the rear end in its bearing on the bridge of the receiver and rotate the bolt in a counterclockwise direction until the tang of the firing pin has cleared the bridge of the receiver. Guide the left locking lug into its groove at a point just in rear of the locking recess on the left side of the receiver; seat the right locking lug onto its bearing; slide the bolt all the way to the rear.

(2) Turn the barrel and receiver group over so that the sights are down. Pick up the operating rod and hold it by the handle so that the handle is up, and insert the piston head into the gas cylinder about  $\frac{3}{8}$  of an inch. Turn the barrel and receiver group over so that the sights are up. With the bolt half opened adjust the operating rod so that the camming recess in the hump fits over the operating lug on the bolt. Move the operating rod to the rear until the rear edge of the handle exactly aligns

with the forward edge of the rear-sight-windage-knob; press down on and move the operating handle forward seating it in its guide groove. Shove it all the way forward.

(3) Turn the barrel and receiver group over so that sights are down. To replace the follower assembly first make sure that the bolt is closed, and then lower the assembly into its grooves in the receiver, follower slide up.

(4) With left hand, replace bullet guide so that shoulders of bullet guide fit in their slots in receiver and hole in projecting lugs is in line with holes in receiver.

(5) With the right hand, swing lower part of bullet guide up slightly. With the left hand, insert the L-shaped rear arm of operating rod catch assembly through clearance cut in bullet guide, making sure that rear end is underneath forward stud on clip catch which projects into receiver. Lower bullet guide into place. Test for correct assembly by pressing down on forward arms of operating rod catch. When released, they should spring back into place. Replace follower arm by passing its studded end through slot in bullet guide and inserting studs in their grooves in follower. Place forked end of follower arm astride projecting lug (toe) of bullet guide. Aligne holes in operating rod catch, follower arm, and bullet guide with those in receiver. Insert follower arm pin in near side (toward body) of receiver and press pin home.

(6) Insert operating rod spring into operating rod. Grasp attached follower rod with left hand, exerting pressure toward muzzle, and seat claws of follower rod about the front studs of follower arm. The hump on follower rod must be in the slot between forward arms of operating rod catch. The straight portion of rod will then be parallel to barrel.

Three main groups. Insert U-shaped flange of stock ferrule in its seat in lower band. Pivoting about this point, guide and press barrel and receiver group into position in stock. Insert trigger housing group, with trigger guard in its open position, into recess in stock. Lower into position, keeping bottom plate of housing always parallel to final position. Do not try to seat front end first. Close and latch trigger guard.

To test assembly of the rifle. Pull operating rod to rearmost position. The bolt should stay open. Close bolt and snap safety to locked position. Press trigger. Hammer should *not* fall. Push safety forward and press trigger. The hammer *should* fall.

Continued next page

POPULAR MECHANICS Jan. 1951

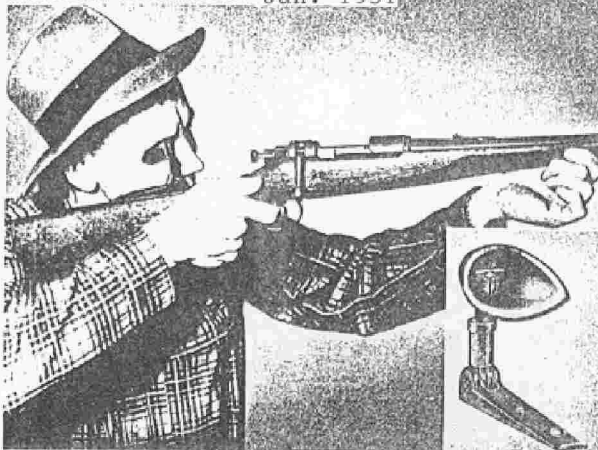

### Eye-Cup Peep Sight

You're on target faster when you use an eye-cup peep sight that eliminates the chore of lining up front and rear sights. Instead, you merely put the front sight on target and that's where the bullet strikes. The rubber cup mounts on the stock of the rifle where the hunter can place his eye against it. Spring action in the sight eliminates recoil. The eye cup also shuts out distracting light rays, making it possible to aim within 10 degrees of the sun. The sight folds down when not in use.

## Chapter II—Functioning

**GENERAL.** The functioning cycle of the M1 Rifle is divided into four phases with certain actions occurring in each phase. It should be remembered that some of these actions are going on at the same time; they are presented here in the order in which they occur. The study of this cycle could commence in any order, but for clarity it is here presented as:

**First phase.** Action upon loading a full clip, to include:

- (1) Movement of follower, follower arm, and follower rod.
- (2) Action of the accelerator and operating rod catch assembly.
- (3) Action of the clip latch.

**Second phase.** Action during the forward movement of the operating rod to include:

- (1) Chambering.
- (2) Locking.
- (3) Alinement of the firing pin.
- (4) Termination of forward movement.

**Third phase.** Action during the rearward movement of the operating rod to include:

- (1) Action of gas.
- (2) Action of operating rod and spring.
- (3) Unlocking.
- (4) Withdrawal of firing pin.
- (5) Extraction.
- (6) Ejection.
- (7) Cocking.
- (8) Feeding.
- (9) Termination of the rearward movement.

**Fourth phase.** Action following firing of 8th round to include:

- (1) Action of follower, follower arm, and follower rod.
- (2) Action of operating rod catch assembly.
- (3) Action of clip latch.
- (4) Ejection of empty clip.

**Action upon loading a full clip.** Place the barrel and receiver group upon a table, sights down, operating rod to the rear. In this position, with the receiver ready to receive a full clip of ammunition, consider the relationship of the parts to each other: The operating rod and bolt are in the rearmost position, the follower being all the way up in the receiver through the action of the compressed operating rod spring which is exerting pressure through the follower rod, follower arm, and against the follower; the hump of the follower rod is in contact with the 45° camming surface of the operating rod catch, camming it towards the barrel and engaging its hook with the hooks on the operating rod, thus keeping the bolt and operating rod to the rear against the tension of the compressed operating rod spring; the rear stud of the clip latch is withdrawn from the receiver due to pressure exerted on the front stud by the long rear arm of the operating rod catch assembly. (Plate 22).

(1) *Follower, follower arm, and follower rod.* By placing a loaded clip on top of the follower and pressing down on the clip, the follower is depressed. This action rotates the follower arm down (it pivots about the follower arm pin) and, since it is connected to the follower rod, it pushes the follower rod toward the muzzle moving the hump of the rod away from the 45° camming surface of the operating rod catch.

(2) *Action of the accelerator and operating rod catch assembly.* As the follower

reaches its lowest point in the receiver, the square shoulder of the follower arm contacts the rear lip of the accelerator, forcing it toward the barrel. Between its lip and the point where it is fastened by its pin to the operating rod catch, the accelerator bears on and pivots about the toe of the bullet guide. Thus as the lip of the accelerator is forced toward the barrel, the operating rod catch is forced away from the barrel.

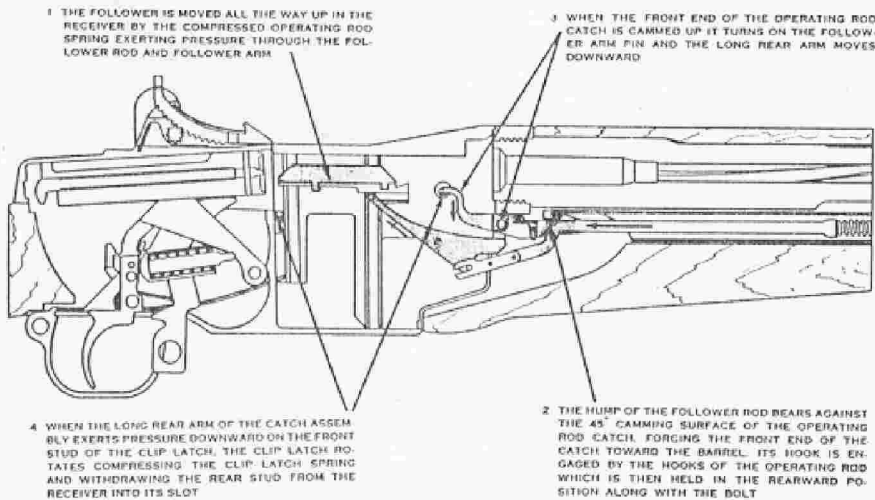

PLATE 22. POSITION OF THE PARTS WHEN THE RIFLE IS READY TO BE LOADED WITH A FULL CLIP

The undercut hook of the operating rod catch is disengaged from the hooks of the operating rod, letting the bolt and operating rod go forward under the action of the expanding operating rod spring. The accelerator plays no other part in functioning except when loading a full clip of ammunition as just described.

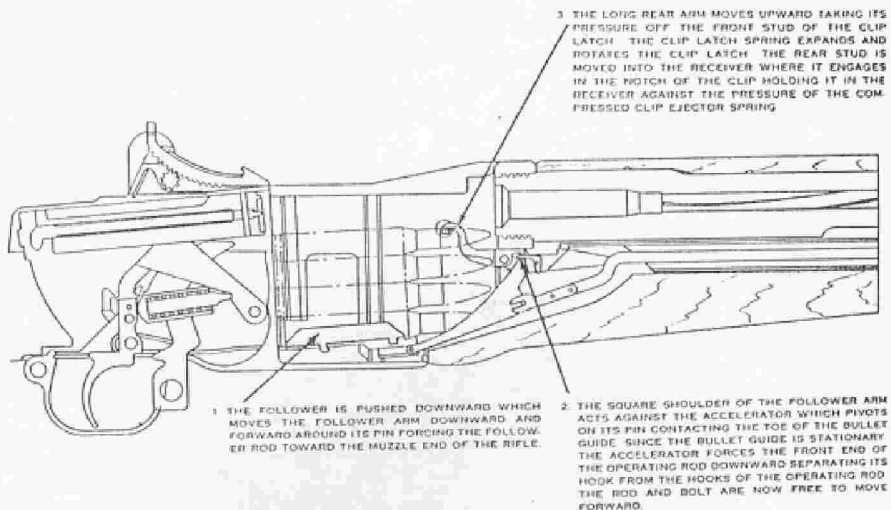

PLATE 23. POSITION OF THE PARTS AFTER A FULL CLIP HAS BEEN PLACED IN THE RECEIVER

(3) *Action of the clip latch.* As the forward end of the operating rod catch moves downward and away from the barrel, the long rear arm of the catch moves upward and away from the front stud of the clip latch. This allows the clip latch spring to expand and force the rear stud of the clip latch into the notch of the clip. The rear stud of the clip latch holds the clip in the receiver against the action of the compressed clip ejector. The operating rod catch is held away from the barrel by the front stud of the clip latch which is continually pushing upward against the long rear arm. This allows the bolt to move freely back and forth until the last round is fired. (Plate 23.) Load a clip of dummy rounds in the receiver several times and carefully notice how each part works.

**Forward movement.** The clip is now in place. Turn the barrel and receiver group over so that the sights are up again. Pull the operating rod all the way to the rear and hold it there. (If dummy rounds are not available for this study, allow the operating rod to go forward a minute distance, just until the operating rod catch no longer functions to hold it to the rear.) The operating rod spring provides the force for the forward movement.

(1) *Chambering.* As the operating rod and bolt, actuated by the compressed operating rod spring, move forward, the bolt strips off the top round of the clip, guiding it into the chamber. When the bolt is fully forward, but not yet locked, the rear of the round has risen up under the extractor which grips the rim, and the ejector is depressed into the face of the bolt against the action of the ejector spring.

(2) *Locking.* When the bolt is fully forward the hump of the operating rod contacts the operating lug on the bolt and rotates the bolt downward or clockwise, locking the bolt.

(3) *Alignment of the firing pin.* Slightly before the bolt reaches its foremost position, the tang of the firing pin contacts the bridge of the receiver, stopping the forward movement of the firing pin. When the bolt is turned and fully locked, the tang of the firing pin is lined up with the slot in the bridge of the receiver and may be driven forward by the hammer. This is a safety feature to make sure that the bolt is fully locked before the live round can be fired. Should the hammer fall before the bolt is fully locked, the bolt camming lug on the hammer will strike the cocking cam on the bolt, causing the bolt to rotate to its locked position.

(4) *Termination of forward movement.* After the bolt has been closed and locked, the operating rod continues forward for  $5/16$  of an inch; the forward movement is terminated when the bolt is locked and the operating rod is fully forward.

**Rearward movement.** The channeling of expanding powder gases provides the force for the rearward movement of the operating parts.

(1) *Action of the gas.* Assume that a cartridge is in the chamber and the hammer is cocked. Squeeze the trigger and fire the cartridge. A chamber pressure of approximately 50,000 lbs. per sq. in. is generated and the bullet is propelled through the barrel. As the bullet passes the gas port this tremendous pressure has been reduced to approximately 2,000 lbs. per square inch. A small part of this gas, seeking the easiest means of escape, expands through the gas port into the gas cylinder and strikes the head of the piston a sudden severe blow, driving the operating rod to the rear, and compressing the operating rod spring.

(2) *Action of operating rod and spring.* For the first  $5/16$  of an inch the operating rod moves independently, allowing it to build up sufficient speed to overcome the inertia of the locked bolt. This "free play" is also a safety feature; it allows the bullet to clear the muzzle with the attendant reduction in chamber pressure before unlocking begins, preventing a blow-back of gases in the firer's face.

(3) *Unlocking.* As the operating rod continues to the rear, the front camming sur-

face in the hump of the operating rod contacts the operating lug on the bolt, turning the bolt counterclockwise, unlocking it.

(4) *Withdrawal of the firing pin.* This action occurs at the same time the bolt is being unlocked. As the bolt is turned counterclockwise, the tang of the firing pin contacts the bridge of the receiver and is cammed to the rear, withdrawing the striker of the firing pin into the face of the bolt.

(5) *Extraction.* Extraction occurs next. Remember that the extractor has been gripping the rim of the cartridge case all the time that the round has been in the chamber. Initially the round is loosened in the chamber as the bolt unlocks, due to a very slight rearward movement of the bolt. As the bolt continues to the rear it pulls the empty case from the chamber.

(6) *Ejection.* When the front of the empty case clears the rear of the chamber, the ejector (which has been continually pushing against the base of the case) ejects the empty case from the receiver by the action of the expanding ejector spring.

(7) *Cocking.* As the bolt moves to the rear, it forces the hammer rearward and downward into the cocked position.

(8) *Feeding.* When the bolt in its rearward movement clears the top round in the clip, the follower, through the action of the compressed operating rod spring on the follower rod and follower arm, moves the top round up into the path of the bolt.

(9) *Termination of the rearward movement.* The rearward movement ends when the square shoulder of the operating rod contacts the front of the receiver.

Action following firing of 8th round. As rounds are gradually exhausted from the clip, the hump of the follower rod approaches the operating rod catch assembly. The contact of these two parts ejects the empty clip and holds the operating rod to the rear.

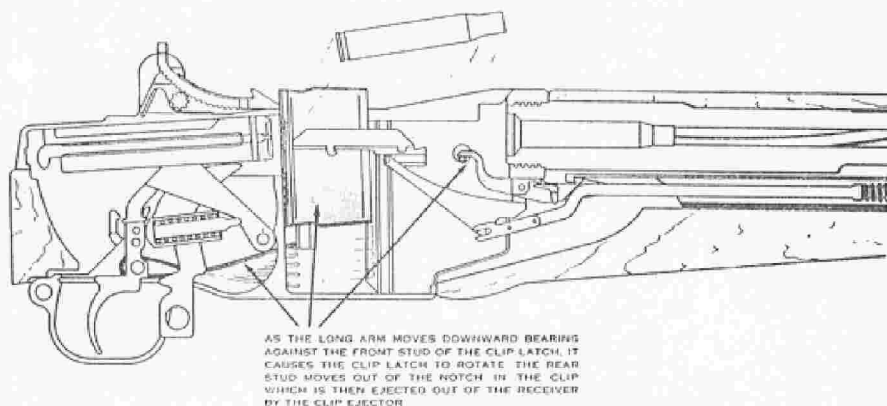

PLATE 24. ACTION FOLLOWING THE FIRING OF THE LAST ROUND

(1) *Action of follower and follower rod.* While the 8th round is in the chamber, the follower is against the bottom of the bolt. When the 8th round is fired, the bolt comes to the rear and the follower, freed of this obstruction, moves all the way up in the receiver. (Plate 24.) The hump of the follower rod makes contact with the 45° camming surface of the operating rod catch and cams the catch toward the barrel.

(2) *Operating rod catch assembly.* As the catch is cammed toward the barrel, its under-cut hook is engaged with the under-cut hooks on the operating rod. The engagement of these hooks holds the bolt open and the operating rod to the rear.



(3) *Clip latch.* When the operating rod catch is cammed toward the barrel, the long rear arm pivots about the follower arm pin and moves in the opposite direction against the front stud of the clip latch. The clip latch rotates, withdrawing the rear stud from the notch on the clip.

(4) *Ejection of empty clip.* The clip, now free from the restraining rear stud of the clip latch, is ejected by the compressed clip ejector.

The operating parts are now in the same position as they were before loading and are ready to receive another full clip.

**FUNCTIONS OF THE TRIGGER HOUSING GROUP.** Cock the hammer and note how it is held in the cocked position by the hammer hooks (on the hammer) which engage the trigger lugs (on the trigger assembly). (Plate 25.) Close and latch the

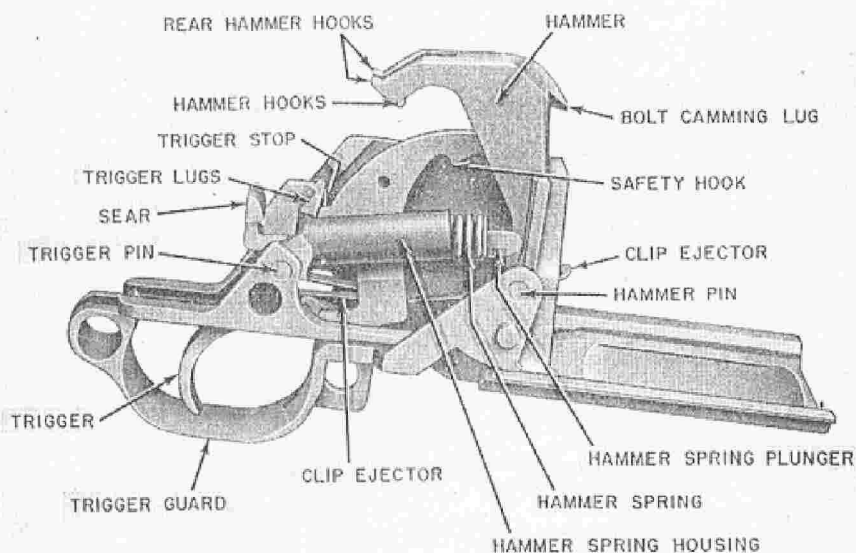

PLATE 25. TRIGGER HOUSING GROUP

trigger guard. Hold the thumb over the hammer and allow it to go forward slowly by squeezing the trigger; note that as trigger lugs are rotated forward about the trigger pin, the hammer hooks are released and the hammer, actuated by the compressed hammer spring, goes forward. This action occurs each time the trigger is squeezed if the pressure on the trigger has been released after each shot. However, the cocking action following each shot is much faster than the firer's release of the trigger, so there must be a means of preventing the hammer from following the bolt forward after each shot when the pressure is maintained. This is accomplished by the sear (on the trigger assembly) which engages the rear hammer hooks. Hold the finger on the trigger and push the hammer all the way to the rear; note how the rear hammer hooks are engaged by the sear. Release the trigger and note how the sear and rear hammer hooks are disengaged and how the trigger lugs again engage the hammer hooks. Squeeze the trigger lightly and note that as the trigger lugs are rotated forward, the sear makes contact with the rear hammer hooks, thus assisting in the squeeze. In marksmanship, this action is spoken of as "slack," and the time between this and the disengagement of trigger lugs and hammer hooks is spoken of as "squeeze."

Cock the hammer and push the safety to the rear or "safe" position. Note how the hook of the safety is engaged over the safety lug of the hammer, thus locking the hammer in the cocked position (with the hammer hooks physically separated from the trigger lugs) so that the hammer cannot fall. Note also that the square shoulder of the safety blocks any forward movement of the trigger lugs. This is an automatic safety feature designed to block the hammer in the event of a broken hook on the safety. (Plate 26.)

# Stunts

TO DEMONSTRATE

# Natural Laws

Scientific Facts Tested  
with Simple Apparatus



**MAGNETIC GLASSES.** In one of the glasses place a lighted candle. Smear the edges of both glasses with lard. Invert one glass over the other as shown. Soon the candle goes out, and the glasses stick together, held by the vacuum that was created by the oxygen-consuming candle flame

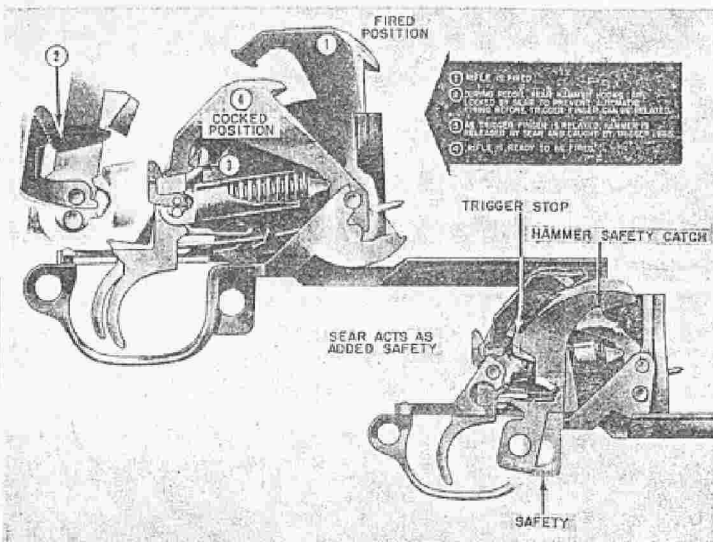
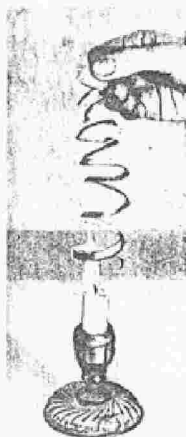

PLATE 26. FUNCTIONING OF THE TRIGGER HOUSING GROUP

**WATCHING METAL EXPAND.** Cut a small spiral from a sheet of tin. Hold this spiral, as shown at right, over a candle flame. The expansion due to heat will be easily seen as the tin stretches when hot and contracts as it cools off



### CAPILLARY ATTRACTION

A tumbler is filled even full of water. A piece of blotting paper, lying on a sheet of glass, is pressed down on top of the tumbler so the water will meet the paper. The tumblerful of water may then be lifted with the plate glass. This is due to the capillary attraction

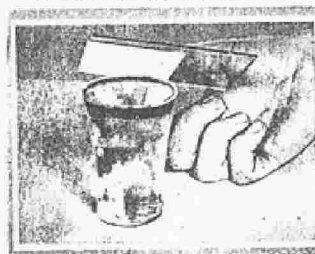

### FIREPROOF PAPER

Place a small piece of tinfoil on a sheet of paper and hold the paper over a flame. It will surprise you to see that the paper will not burn until the tinfoil has melted. This is due to the rapidity with which tinfoil conducts heat, thus keeping the temperature of the paper so low that it cannot burn

### MAKING SUGAR BURN

As you know sugar melts without burning with a flame. Place a pinch of cigarette ashes on a piece of sugar and hold it in a flame. Due to the catalytic action of the ash, the sugar will burst into flame

### Chapter 3 —Operation, Immediate Action and Stoppages

**TO LOAD.** When ammunition is not issued in loaded clips, insert eight rounds into the clip so that the base of each round is flat against the back of the clip. The bottom round should be against the left side of the clip (the rifle will fire whether the round is on the right or the left, since the follower slide automatically adjusts itself). This facilitates the loading by a right-handed man, since the ball of his thumb will



PLATE 27. LOADING THE RIFLE

be on the top round and not his slippery fingernail as would be the case if the top round is in the left. Except in continuous firing, loading is accomplished with the rifle locked. Hold the rifle at the balance with the left hand, and pull the operating handle all the way to the rear with the right hand. Place a loaded clip on top of the follower; raise the elbow high; place the ball of the thumb on the top round, just below its middle; and push the clip straight down into the open receiver. The pressure of the thumb on the top round holds the bolt to the rear (by this time the accelerator has functioned and the bolt is free to move forward). Swing the thumb to the right front smartly. With rifles which have been used extensively, the bolt may remain open; when this occurs, strike the operating rod handle smartly with the heel of the right hand and drive it forward. Do not ride the handle forward, because the bolt will not lock and a stoppage will occur on the first round.

**TO UNLOAD.** To unload a cartridge from the chamber, hook the right thumb over the operating rod handle, pull and hold the operating rod in the extreme rear position. This extracts and ejects the round.

To remove the loaded clip from the receiver, hold the rifle with your right hand, thumb on the operating rod handle, fingers around the trigger guard, and the rifle butt resting on your right groin. Place the palm of your left hand over the receiver and

press in on the clip latch with your left thumb. The clip is ejected upward from the receiver and into your left hand. Do not allow the bolt to move forward during the operation as it will push the top cartridge forward and prevent ejection of the clip.

To close the bolt on an empty chamber and retain a partially loaded clip in the receiver, press down on the top cartridge in the clip, allowing the bolt to slide forward over it; make sure that the bolt is fully closed. This can be done only when there are less than eight cartridges in the clip.

**OPERATION AS A SINGLE LOADER.** The receiver being empty, pull the operating rod to the rear until it is caught by the operating rod catch. With the right hand, place one round in the chamber, seating it in place with the thumb. With the palm of the right hand against the receiver, the rear edge of the right hand against the operating rod handle, the fingers extended, joined, and pointing downward, force the operating rod handle slightly to the rear; depress the follower with the right thumb; and permit the bolt to ride forward about one inch over the follower. Then remove the thumb from the follower and release the operating rod handle.

**TO LOAD PARTIALLY FILLED CLIP.** Using one hand. To partially load a clip from any firing position, hold the rifle with your left hand at the firing position, with the butt of the rifle resting on a secure surface (the groin, thigh, or ground). Move the operating rod handle to its rearmost position with your right hand, opening the bolt. Place the empty clip into the receiver. Next, place the first cartridge into the clip and on the follower with the right hand. Press the second cartridge into the clip, exerting a downward turning motion toward the center of the clip with the right thumb until the cartridge snaps into place. In the same manner, continue to load the clip. After placing the last cartridge into the clip, loading is completed by pressing down slightly on the top cartridge with the right thumb, at the same time moving the operating rod handle slightly to the rear with the right edge of the right hand. Let the bolt move forward about one inch; this starts the top round forward. Remove your right hand and allow the operating rod to go forward. This method of loading is useful in combat when a full clip of ammunition is not available.

**CAUTION.** While pressing rounds into the clip keep the palm of the right hand against the receiver and in front of, but not touching, the operating rod handle. This will prevent the bolt from going forward and injuring the right thumb while loading rounds into the clip.

**Using both hands.** Place the empty clip on a solid surface, gripping the sides of the clip with the thumb and middle finger of the right hand. With the left hand, insert the cartridges into the clip and hold them in place with the right forefinger inside the clip. When the rounds (less than eight) have all been inserted into the clip, place the clip on top of the follower without changing your grasp with your right hand. Use your left hand to assist in holding the cartridges in place and slide the clip down until the lip engages the top cartridge. Regrasp the rifle with the left hand at the firing position. Press down on the top cartridge with the right thumb, the palm of the right hand against the stock, and the side of the hand pressing the operating rod handle slightly to the rear. When the clip is engaged by the rear stud of the clip latch, allow the bolt to move forward about an inch, withdraw the right thumb, release the operating rod handle; this allows the bolt to close and lock.

Whether using one or both hands, care should be taken to insure that the base of each cartridge is against the rear wall of the clip.

**TO SET RIFLE AT SAFE.** The loaded rifle is kept locked until the moment of firing. To lock the rifle, snap the safety to its rear position inside the trigger guard. In this position, the trigger cannot be squeezed because the upper end of the trigger is

## TABLE OF MALFUNCTIONS

Malfunction	Cause	Correction by soldier
Failure to chamber.	<ol style="list-style-type: none"> <li>(1) Dirty or rough chamber.</li> <li>(2) Restricted gas port.</li> <li>(3) Dirty or improperly lubricated rifle.</li> <li>(4) Bent clip.</li> <li>(5) Ruptured cartridge case in chamber.</li> </ol>	<ol style="list-style-type: none"> <li>(1) Clean chamber.</li> <li>(2) Clean gas port.</li> <li>(3) Clean and lubricate rifle.</li> <li>(4) Replace clip.</li> <li>(5) Remove ruptured cartridge case.</li> </ol>
Failure to fire (hammer releases but rifle does not fire).	<ol style="list-style-type: none"> <li>(1) Bolt not seated and locked.</li> <li>(2) Defective or broken firing pin.</li> <li>(3) Defective ammunition.</li> </ol>	<ol style="list-style-type: none"> <li>(1) Pull operating rod handle halfway to the rear and release it. Insure complete locking.</li> <li>(2) Replace firing pin.</li> <li>(3) Discard round.</li> </ol>
Failure to extract.	<ol style="list-style-type: none"> <li>(1) Dirty or rough chamber.</li> <li>(2) Restricted gas port.</li> <li>(3) Dirty ammunition.</li> <li>(4) Failure to replace extractor plunger and spring.</li> <li>(5) Broken extractor.</li> </ol>	<ol style="list-style-type: none"> <li>(1) Clean chamber.</li> <li>(2) Clean gas port.</li> <li>(3) Discard or clean round.</li> <li>(4) Replace extractor plunger and spring.</li> <li>(5) Replace extractor.</li> </ol>
Clip jumps out on seventh round.	Bent follower rod.	Replace follower rod.
Fires in bursts of two or three rounds.	<ol style="list-style-type: none"> <li>(1) Sear broken or worn, or remains in open position.</li> <li>(2) Hammer spring housing improperly assembled.</li> </ol>	<ol style="list-style-type: none"> <li>(1) Replace trigger assembly or hammer spring housing.</li> <li>(2) Disassemble and assemble trigger housing group correctly.</li> </ol>
Safety releases when pressure is applied on trigger.	Worn trigger stop on safety or broken safety.	Replace safety.
Pressure on trigger does not release hammer.	<ol style="list-style-type: none"> <li>(1) Deformed hammer or trigger, or worn trigger pin.</li> <li>(2) Trigger strikes trigger housing</li> </ol>	<ol style="list-style-type: none"> <li>(1) Replace defective part.</li> <li>(2) Turn in to ordnance.</li> </ol>
Jumping rear sight.	Loose rear sight nut.	Tighten rear sight nut.
Creep in trigger.	Burs on trigger lugs or hammer hooks.	Replace trigger, or hammer or both.

PLATE 28. TABLE OF MALFUNCTIONS

blocked by the square shoulder of the safety (thus preventing the trigger lugs from disengaging the hammer hooks) and because the hook of the safety is engaged with the safety lug on the side of the hammer (thus preventing the hammer from moving forward). When *locked*, the rifle may be loaded or unloaded and operated by hand but cannot be fired. To unlock the rifle, push the safety to its forward position.

**TO CLEAR RIFLE.** To clear the rifle, pull the operating rod fully to the rear, extracting and ejecting the cartridge from the chamber. Remove the clip from the receiver and *leave the bolt open*. Inspect the receiver and chamber to insure that they are empty.

**TO ADJUST REAR SIGHT.** The rear sight is adjusted for range by turning the elevating knob. This knob has numbered graduations for 200, 400, 600, 800, 1,000, and 1,200 yards of range and index lines between these graduations for 100, 300, 500, 700, 900, and 1,100 yards. Adjustment for windage is made by turning the windage knob.

Each windage graduation on the receiver represents an angular adjustment of 4 minutes. Elevating and windage knobs are graduated in "clicks" which represent 1 minute of angle or approximately 1 inch on the target for each 100 yards of range. Arrows on the knobs indicate the direction in which to turn them to obtain corresponding changes in the point of impact of the bullet.

**SAFETY PRECAUTIONS.** Safety cannot be overemphasized. Whenever working with weapons, constant care and checking are necessary. Some of the precautions to observe in handling this rifle follow; these precautions are not intended to replace other existing safety regulations:

A rifle with its bolt closed is never considered to be safe until it has been properly inspected.

Do not playfully or carelessly point the rifle at anyone. Always consider the rifle loaded. Do not leave any obstruction in the muzzle or bore.

**STOPPAGES.** All instruction in mechanical training has been directed to the thorough understanding of the rifle so that the soldier understands the causes of stoppages and consequently what action is necessary to reduce them. A stoppage is any unintentional cessation of fire. *Immediate action is the unhesitating application of a probable remedy to reduce a stoppage without investigating the cause.*

**IMMEDIATE ACTION.** If the rifle fails to fire, pull the operating rod handle *all the way* to the rear with the right hand, *palm up*; release it, *aim and fire*. This action will reduce approximately 95% of all stoppages. If the application of immediate action fails to clear up the trouble and it is necessary to continue firing, work the operating rod handle manually until you have sufficient time to investigate.

The remaining 5% of stoppages which are not remedied by the action described above fall, roughly, into three classes: *Failure to chamber, failure to fire, and failure to extract*; other stoppages are presented in the table (Plate 28). The necessary corrective action, based upon the knowledge of functioning, is presented in the table of malfunctions.

#### SCIENCE AND MECHANICS

### Bunsen Burner Easy to Make From Oil Can

**S**AW the entire spout from the cover of an oil can. Over the opening solder a thin brass disk slightly larger than the hole. Through center of disk drill a hole  $\frac{1}{2}$  inch in diameter, for the gas orifice.

A five inch length of 1" brass tubing is centered on the oil can cover and soldered in place. About  $3\frac{3}{4}$  inches from top of tube drill a half inch hole to admit air to the mixing chamber. Because the air-gas mixture must be regulated, a 1" width of spring brass slightly shorted than the circumference of the tube is bent into a ring and slipped on the pipe.

This air inlet cover must suck up and down fairly easily over the hole.

Now drill a hole near the base of the oil can large enough to admit a 3" length of  $\frac{3}{8}$ " copper tubing and solder tubing in place. A flexible rubber hose is slipped over this pipe and the opposite end is attached to the gas outlet.

Spread shellac on lid gasket and assemble unit. Screw lid down tightly so gas will not escape. A

bit of ordinary copper screen is inserted at top of burner as shown.

In use, the air inlet is closed when the burner is lighted. Open air control until a bright blue flame appears.—E. E. SWANSON.

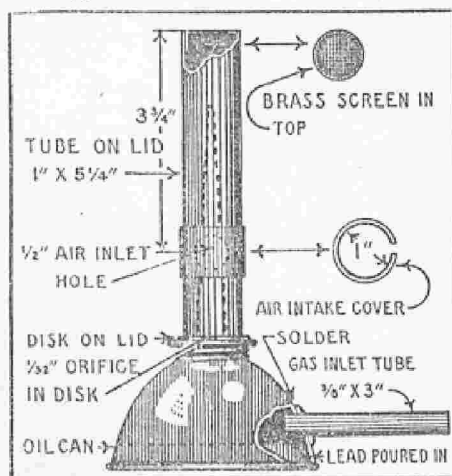

## Chapter 4 — Spare Parts, Appendages, and Accessories

**SPARE PARTS.** The parts of any automatic or semiautomatic rifle will in time wear out or break; sets of spare parts are issued for the replacement of these articles. Whenever a spare part from the set is used, it should be replaced by another as soon as possible. Spare parts should be maintained complete so that they are ready for immediate insertion into the rifle.

**APPENDAGES. General.** Appendages for the rifle are the bayonet and grenade launcher.

**Bayonet.** The bayonet is a blade sharpened along the entire lower edge and partially along the upper edge. It is constructed so as to fit securely into the scabbard or onto the muzzle end of the rifle. Handles on its base make it a suitable hand weapon.

**Grenade launcher.** The grenade launcher is a short tubular adaptation which is attached to the muzzle of the rifle enabling it to project various types of grenades.

**ACCESSORIES. General.** Accessories include the tools required for disassembly and cleaning of the rifle; the gun slings, spare parts containers, covers, arm lockers, and similar articles. They should not be used for purposes other than for which intended and, when not in use, they should be stored in places provided for them.

**Arm locker, and rack.** The arm locker and the arm rack are used to store or stack rifles and pistols to prevent mishandling or pilfering.

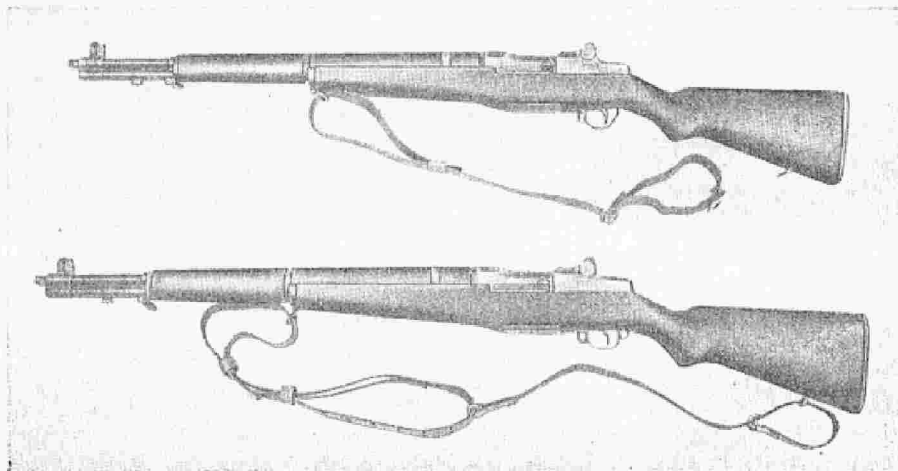

PLATE 29. GUN SLINGS

**Barrel reflector.** This is a small, L-shaped device having a short tube which slips into the chamber of the rifle barrel. It also has a mirror and an opening through which the reflection of the bore is obtained. The condition of the rifle bore may thereby be readily determined.

**Brush and thong.** The brush and thong are used for cleaning the bore of the rifle. The oiler and thong case is partitioned so that one end contains the oil and oil dropper and the other holds the tip, weight, thong, and brush.

**Cleaning rod M3.** The cleaning rod is of such length as to prevent damage to the



follower or the face of the bolt. The rod has a handle at one end and is threaded at the other end to receive the patch or brush sections. The patch section is slotted to permit the insertion of a cleaning patch; the brush section is used to clean the bore of the rifle after firing.

**Combination tool.** This tool consists of three parts, the chamber-cleaning brush, the handle, and the screw driver blade. The movable screw driver blade is used for adjusting the gas cylinder lock screw and various other screws while the notched blade of the handle is used on the rear sight locking nut. The small cylindrical projection is used to drift out pins. It is also used, together with the V-shaped groove cut into the face of the handle, to assemble the extractor and ejector. The curved undercut lug or hook, commonly called the hand extractor, is used to extract a cartridge case which the extractor has failed to withdraw.

**Gun slings.** Slings are perforated adjustable leather (or web) belts attached to the underside of the weapon. They provide a means of carrying the rifle over the shoulder. In marksmanship, they provide great assistance in steadying the rifle. Slings are normally issued already attached to the rifle as indicated in Plate 29.

**The ruptured cartridge extractor.** This extractor has the general shape of a caliber .30 cartridge and consists of three parts; the spindle, the head, and the sleeve. To use the ruptured cartridge extractor, the cartridge clip and live cartridges must be removed from the rifle. The ruptured cartridge extractor is then inserted through the opening of the ruptured case and pushed forward into the chamber. Allow the bolt to close without excessive shock so that the extractor on the bolt engages the head of the ruptured cartridge extractor. When the bolt is opened, the ruptured cartridge extractor will remove the ruptured cartridge.

**The M2 aiming device.** (Plate 30). This is an instructional aid that allows the coach to positively check the pupil's sight picture during preparatory marksmanship training and range practice. As the coach looks into the aiming device, he sees reflected on the glass an image of the sight picture as the rifleman sees it. This allows the coach to check on those men who do not hold their breath properly, and it enables him to help the inexperienced rifleman to obtain the correct sight picture. The device is attached by fitting the two extensions over the rear sight.

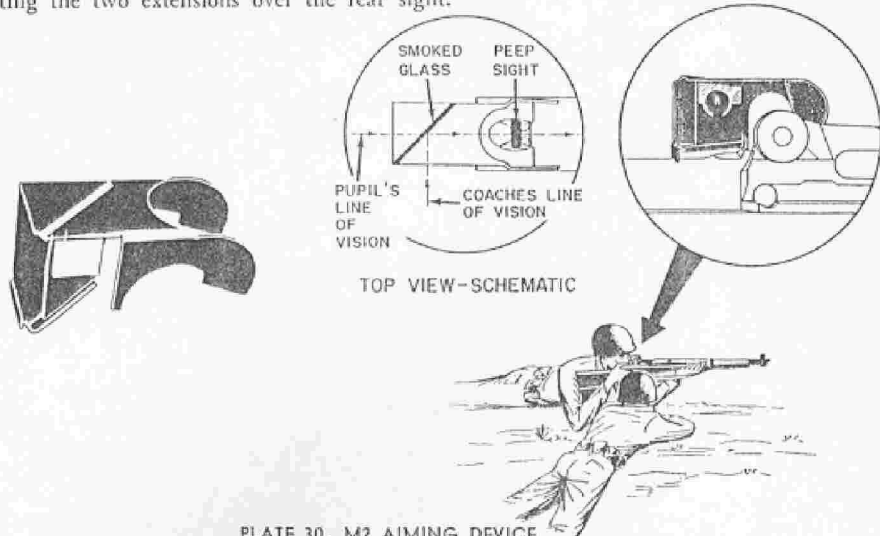

PLATE 30. M2 AIMING DEVICE

## Chapter 5 —Ammunition

**AMMUNITION.** The information which follows pertains to the several types of cartridges used in the M1 rifle.

**CLASSIFICATION, DESCRIPTION, AND USE.** The ammunition that you may use in the M1 rifle is described in this section. This rifle can fire several types of ammunition. You are responsible for being able to recognize these types, to know which is best to use for certain targets, and to properly care for the ammunition.

In most types of small-arms ammunition, a cartridge consists of a cartridge case, primer, propelling charge, and the bullet. Plate 31 shows the construction of a typical cartridge and its parts.

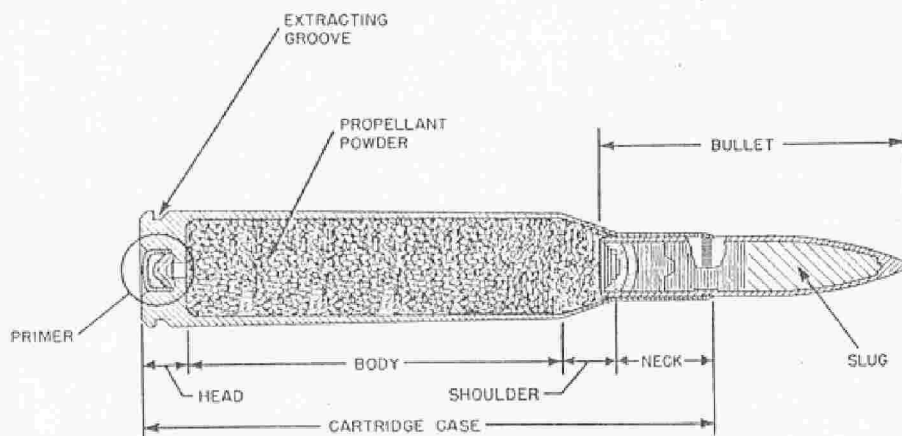

PLATE 31. PARTS OF THE CALIBER .30 ROUND

The term *bullet* refers only to a small arms projectile. The term *ball* was originally used to describe the ball shaped bullet of very early small arms ammunition. The term *ball ammunition* now refers to a cartridge having a bullet which has a metallic jacket filled only with lead.

Based on use, the principal classifications of the several types of ammunition used with your rifle are:

- (1) Ball, M2—for use in marksmanship training.
- (2) Tracer, M1—observation of fire, incendiary, and signaling purposes.
- (3) Armor-piercing, M2—for use against lightly armored vehicles, protective shelters, and personnel.
- (4) Incendiary, M1—for use against inflammable material.
- (5) Armor-piercing incendiary, M14—used in place of either the armor-piercing or incendiary cartridges.
- (6) Rifle grenade cartridge, M3—used in propelling grenades.
- (7) Blank, M1909—for simulated fire, signaling, and salute.
- (8) Dummy—used for training.

**LOT NUMBERS AND GRADE.** When ammunition is manufactured it is given a lot number which is marked on packing containers and on a card inclosed within

each box. The lot number is used for purposes of record. Make sure that ammunition of one lot is not mixed with that of another lot.

**CARE, HANDLING, AND PRESERVATION.** Small arms ammunition is not dangerous to handle. It should not be stored near sources of heat, as heat produces a chemical change which increases the powder strength. If it becomes wet, lightly corroded, or dirty, wipe it off at once, but do not polish or oil it. Boxes of ammunition should not be opened until ready for use. If boxes become broken, they should be repaired at once and re-marked if necessary. Except in an emergency, no .30 caliber ammunition should be fired until it is identified as to lot number and grade.

Protect ammunition from mud, sand, and water. If it gets wet or dirty, wipe it off at once with a clean, dry cloth. Light corrosion should be wiped off as soon as it is discovered. Heavily corroded cartridges must be turned in.

During marksmanship and combat training, no caliber .30 ammunition will be fired until it has been identified by an ammunition lot number and grade.

Do not expose ammunition to the direct rays of the sun. If the powder is heated, excessive pressure may be developed when the weapon is fired. This condition will affect ammunition performance.

Do not oil or grease ammunition. The dust and other abrasives that collect on greasy ammunition are injurious to the operating parts of the rifle.

Do not attempt to fire cartridges that have bad dents, scratches, or loose bullets, or those that are corroded. If you think a cartridge is defective, return it. Do not throw away or attempt to destroy defective ammunition.

**BALLISTIC DATA.** Approximate maximum ranges and average velocities are shown below:

Type and model of caliber .30 cartridge	Average muzzle velocity (feet per-second)	Approximate maximum range (yards)
A. P. I. M14 (Standard for all ground combat use) ...	2,830	3,300
Ball, M2 .....	2,800	3,500
Tracer, M1 .....	2,750	3,350
Armor-piercing, M2 .....	2,770	3,160
Incendiary, M1 .....	3,020	2,875

**PRECAUTIONS IN FIRING BLANK AMMUNITION.** It is dangerous to fire blank cartridges at personnel at less than 20 yards, as the wad or paper cup may fail to break up within this distance.

Misfires in which the primer explodes but fails to ignite the powder charge may prove dangerous when blank ammunition is being fired. In this type of misfire, some of the powder may be blown into the bore of the weapon. A series of such rounds in which the powder fails to ignite (because of moisture or other causes) will result in serious damage when the accumulated powder is ignited by a subsequent cartridge. When misfires are encountered in blank ammunition in excess of five percent, the lot will be withdrawn and reported to the Ordnance Corps.

## Chapter 6 —Care and Cleaning

**GENERAL. Responsibility.** The care, cleaning, and preservation of the rifle is an important duty. It is the responsibility of all concerned with the rifle to see that it is properly performed, since experience has proven that more rifles become unserviceable through lack of care than from firing. This axiom holds true even under the rigors of combat.

**Materials.** The materials used in care and cleaning are:

### (1) *Cleaning materials:*

*Soap and water.* Used to clean only the bore and gas cylinder.

*Rifle-bore cleaner.* Used for cleaning the bore after firing; contains rust preventive properties of a very temporary nature and will dissolve the primer-salts which collect moisture; its use should be followed by immediate drying and application of a special preservative lubricating oil.

*Dry-cleaning solvent.* A non-corrosive, petroleum-base liquid used for removing grease and rust-preventive compound; it is highly inflammable, and also will attack and discolor rubber; generally used as a bath for small parts and applied with rag swabs to large parts.

*Decontaminating agents.* Used under special conditions to remove chemical agents.

### (2) *Lubricants:*

*Medium preservative lubricating oil* is a highly refined, non-hardening mineral lubricating oil containing a rust inhibiting additive. It forms a relatively heavy film which resists the direct action of salt spray. These characteristics make it useful for coating all parts of the weapon before landing operations. Use it in preference to preservative lubricating oil, special, only when the rifle is to be exposed to salt water, high humidity atmospheric conditions, or high temperatures.

*Special preservative lubricating oil* is a thin oil used for lubricating at normal and low temperatures and for providing temporary protection against rust. Use this oil for preserving the bore after the rifle has been fired and cleaned. Make frequent inspections to assure maintenance of an adequate protective film of oil.

*Rifle grease.* Possesses high resistance to the action of water. It is used sparingly on those parts subject to heavy wear in wet climates or during amphibious operations. (Plate 32.) It is issued in small plastic containers and is carried in the rifle butt recess.

*Engine oil, SAE 10* may be used when the oils mentioned above cannot be obtained. In cold weather any oil as heavy as this causes sluggish operation and may prevent the rifle from working. This alternate oil does not possess the rust preventive properties of preservative lubricating oils. When engine oil is used, the weapons must be examined, cleaned, and reoiled frequently.

### (3) *Preservatives:*

*Medium rust-preventive compound* is issued for protecting the metal parts for long periods of time while the rifles are boxed and in storage. Warm it before application. When you have no way to heat it, brush it onto the parts when the temperature of the atmosphere is about 80° F. At temperatures below 80° F, medium rust-preventive compound becomes thick and sluggish and it is not economical to use it without pre-heating.

*Raw linseed oil.* A vegetable oil used to prevent drying of the wooden parts and to preserve them. Applied with long strokes of the hand, it materially enhances the appearance of wood.

*Neat's-foot oil.* A pale, yellow animal oil used to keep leather supple and pliant.

**Abrasives and metal-fouling solution.** Abrasives (emery cloth, sandpaper, etc.) must never be used on the rifle, nor may metal-fouling solutions be used by other than Ordnance personnel.

**CARE AND CLEANING WHEN NO FIRING IS DONE.** This includes the care of the rifle necessary to preserve its condition and appearance during periods when no firing is done.

The bore should always be cleaned by inserting a cleaning rod into the muzzle end. If a rod longer than the M3 is used, the follower and face of the bolt must be protected against damage by the rod. Run a patch forward and backward through the bore several times, making sure that the patch goes all the way through before reversing the direction. Replace the patch and repeat until it comes out clean. Run an oily patch (special preservative lubricating oil) through the bore.

Clean the small screw heads and crevices with a small brush or stick. Many a shaving brush has spent its declining years at this service. Clean the metal parts with a dry cloth and wipe with an oil-dampened cloth to provide a protective finish. Wipe the stock and hand guards with a clean cloth and rub in linseed oil. Preserve the leather sling with neat's-foot oil as required.

Place the rifle in its rack. Do not use muzzle plugs or covers as they promote the collection of moisture which subsequently turns to rust.

**PREPARATORY TO FIRING.** The operation described above will preserve the rifle indefinitely, but certain other things must be done to prepare it for firing.

Dismount the three main groups, clean thoroughly, making sure that the bore and chamber are clean and *dry*.

Remove the gas cylinder lock screw and ascertain that the gas port is clean. If it is plugged, a paper clip will open it.

Put a light coat of oil on all metal parts which do not come in contact with the ammunition. (Oil is a liquid and only slightly compressible. If it enters the chamber, the cartridge is prevented from normal expansion when fired, and ruptured cartridges may result.)

Apply oil minutely to the working parts, including bolt lugs, bolt guides, cocking cam on bolt, contact surfaces of barrel and operating rod, operating rod guide groove on side of receiver, operating rod spring, and the cammed surface in the hump of the operating rod.

**AFTER FIRING.** General. After a weapon is fired, primary consideration is the prevention of rust. The residue left after firing consists mainly of primer salts, powder ashes, metal fouling, and carbon. In most small arms ammunition (carbine excluded), the primer contains a salt which collects moisture like table salt. It collects about the chamber and may be deposited throughout the bore. Rifle bore cleaner will remove it. Powder ashes are easily blown away. Metal fouling is almost a bygone worry in the day of jacketed bullets, so much so that only Ordnance personnel are permitted to remove it. Carbon, formed by cooling powder gasses, clings to the entire gas system and is a constant worry both because it can clog the rifle into malfunctioning and because it promotes rust. Rifle-bore cleaner will also remove it although considerable effort is required.

**Cleaning procedure after firing.** The rifle must be cleaned the same day it is fired and for three days, at least, following the day of last firing.

(1) *Bore and chamber.* Using the same equipment as for garrison cleaning, follow this sequence:

- Wet patches (rifle-bore cleaner or hot soapy water; the former is preferred)
- Rifle bore brush

Wet patches

Dry patches

Inspection (Repeat the above until a dry patch comes out clean; the bore is then ready for detailed inspection)

Oily patch

**NOTE:** The chamber must receive special attention as it is larger than the bore. Use the chamber cleaning brush on the combination tool and follow the sequence outlined above. To use the chamber cleaning brush, place it on a patch held in the left hand. Close the left hand over the patch and brush and give the brush about three turns to the right. This causes the patch to wrap neatly around and cover the brush. A slight pressure with the forefinger of the left hand while turning the brush, will twist the end of the patch like the finished end of a hand rolled cigarette. This insures cleaning the full length of the chamber. Clean by twisting the patch-covered brush in the chamber.

(2) *Gas system.* Remove the gas cylinder lock screw and clean it thoroughly, using rifle-bore cleaner. Using a paper clip or pin, make certain that the gas port in the barrel and cylinder is open. Clean the gas cylinder in the same way as the bore was cleaned. Scrape the head of the piston clean after it has been removed from the rifle; use rifle-bore cleaner on the piston and rod. Be sure all carbon deposits are removed before assembling; oil lightly both exterior and interior.

(3) *Remainder of operating parts.* Disassemble and wipe clean. Oil lightly and assemble.

(4) *Exterior surfaces.* Give them the same care as when no firing was done.

**ON RANGE, DURING FIELD FIRING, OR DURING OPERATIONS.** To obtain a maximum of efficiency and to prevent damage to the rifle the following points must be observed:

(1) Never fire the rifle with *any* obstruction in the bore.

(2) Keep the chamber clean (prevents stoppages) and dry (prevents ruptured cartridges).

(3) Never leave any obstructions in the bore—they promote rust and are easily forgotten.

(4) Watch for excessive friction, characterized by sluggish operation; if it occurs, oil all the metal parts which do not contact the ammunition.

(5) If the rifle is exposed to severe rain or salt spray and the bolt fails to operate, oil as above, and apply rifle grease sparingly to parts shown in Plate 21. To apply oil or grease, dismount the three main groups or apply directly to assembled rifle with a matchstick or the oiler.

(6) Keep a thin film of oil on all metal parts except those touching the ammunition.

(7) Keep the rifle clean, paying particular attention to carbon deposits.

(8) In emergencies, any clean light mineral oil (SAE #10) may be used in lieu of prescribed lubricants.

(9) Inspect, or have rifles inspected, frequently and periodically.

CAMMING SURFACE IN  
HUMP OF OPERATING ROD

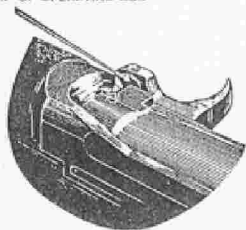

LIP OF RECEIVER

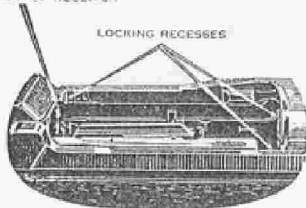

LOCKING RECESSES



BOLT CAMMING  
LUG

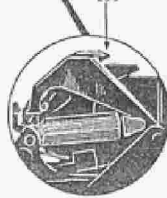

PLATE 22. POINTS ON WHICH TO APPLY RIFLE GREASE

# Harmless 4th of July Display Piece

JULY/AUGUST, 1933

FOR the entertainment of your club or neighborhood party this unique Fourth of July display is well worth building. Cost is negligible, being made principally of pasteboard and plywood. In traditional manner, Mrs. O'Leary's cow sets off the con-

flagration which progresses from one building to another, each setting off a different colored fire, interspersed with an occasional mild explosion and ending up with a grand finale of pin-wheels, flower pots and similar pyrotechnics.

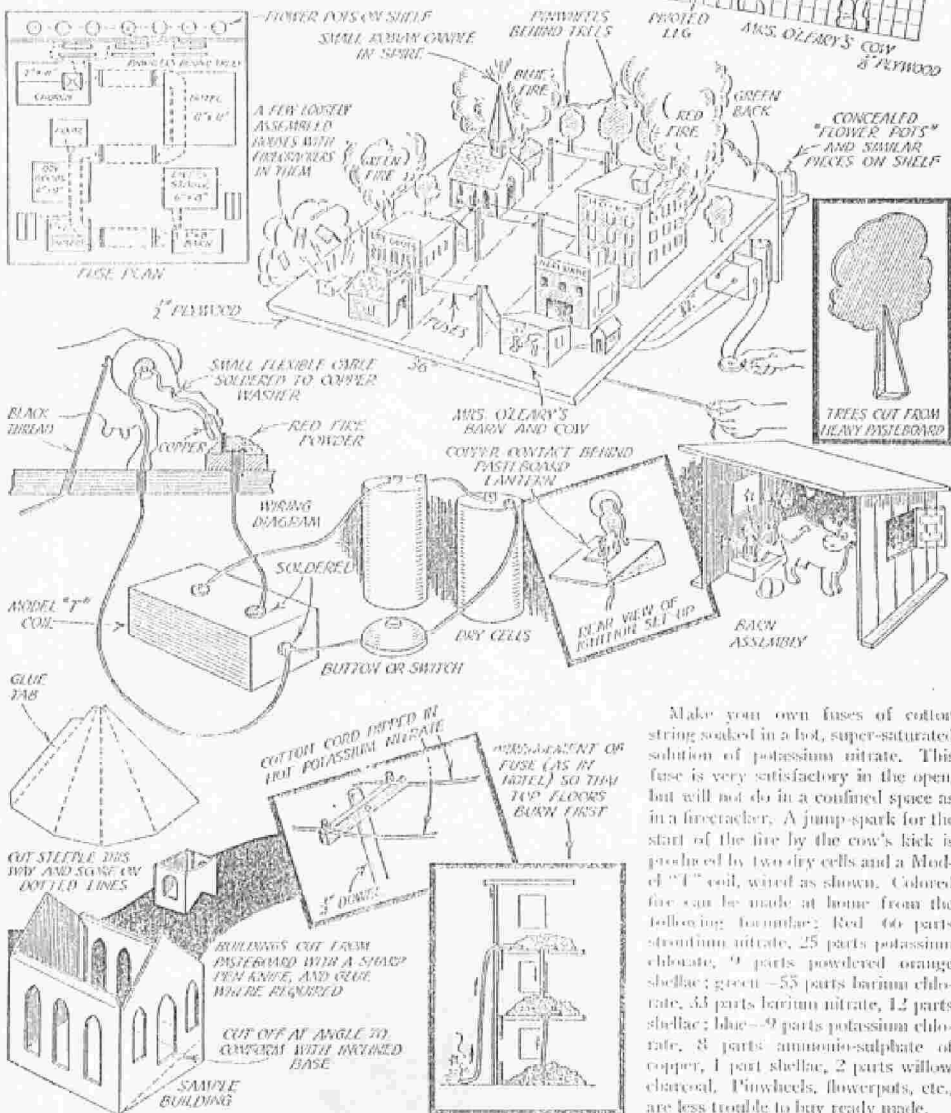

Make your own fuses of cotton string soaked in a hot, super-saturated solution of potassium nitrate. This fuse is very satisfactory in the open, but will not do in a confined space as in a firecracker. A jump-spark for the start of the fire by the cow's kick is produced by two dry cells and a Mod-<sup>o</sup> "I" coil, wired as shown. Colored fire can be made at home from the following formulae: Red—60 parts strontium nitrate, 25 parts potassium chlorate, 9 parts powdered orange shellac; green—55 parts barium chlorate, 35 parts barium nitrate, 12 parts shellac; blue—9 parts potassium chlorate, 8 parts ammonio-sulphate of copper, 1 part shellac, 2 parts willow charcoal. Pinwheels, flowerpots, etc., are less trouble to buy ready made.



## Principles of Interrogation FM 30-15

Interrogation is the art of questioning and examining a source in order to obtain the maximum amount of usable information. The goal of any interrogation is to obtain useful and reliable information in a lawful manner and in a minimum amount of time, meeting the intelligence requirements of any echelon of command. Sources may be civilian internees, insurgents, enemy prisoners of war, defectors, refugees, displaced persons, agents or suspected agents, or other non-US personnel. A good interrogation produces needed information which is timely, complete, clear, and accurate. An interrogation involves the interaction of two personalities, the source and the interrogator. Each contact between these two differs to some degree because of the individual characteristics and capabilities of the participants. Furthermore, the circumstances of each contact and the physical environment are variables. Additionally, there are many types and forms of intelligence interrogations, such as the interview, the debriefing, and the elicitation. There are, however, certain principles which can be considered to have general applicability to all types of interrogations, namely, the objective, initiative, accuracy, prohibition against use of force, and security.

### Objective

Each interrogation must be conducted for a definite purpose. The interrogator must keep this purpose firmly in mind as he proceeds to obtain the maximum amount of usable information to satisfy the assigned requirement and thus contribute to the successful accomplishment of the unit's mission. The objective may be so specific as to establish the exact location of a minefield, or it may be general, seeking to obtain order of battle information about a specific echelon of the enemy forces. In either case, the interrogator must use the objective as a basis for planning and conducting the interrogation. He should attempt to prevent the source from becoming aware of the true objective of the interrogation. The interrogator should not concentrate on the objective to the extent that he overlooks or fails to recognize and exploit other valuable information extracted from the source. For example, during an interrogation the interrogator learns of the presence of a heretofore unknown, highly destructive weapon. Although this information may not be in line with his specific objective, the interrogator must develop this important lead to obtain all possible information concerning this weapon. It then becomes obvious that the objective of an interrogation can be changed as necessary or desired.

### Initiative

■ Achieving and maintaining the initiative is essential to a successful interrogation just as the offense is the key to success in combat operations. The initiative in any interrogation must rest with the interrogator throughout the entire interrogation. He will have certain advantages at the beginning of an interrogation which will enable him to grasp the initiative and assist in maintaining this initiative throughout the interrogation.

- The source, especially if detained by military forces during tactical operations, normally has undergone a traumatic experience and fears for his life. This anxiety is usually intensified by the source's lack of knowledge and understanding of what is about to occur (fear of the unknown), or by the unfounded fear that he will be tortured or executed.
- The interrogator has a position of authority over the source. The source realizes this fact, and, in some cases, believes that his future might well depend upon his association with the interrogator.
- The interrogator clearly knows the purpose of the interrogation; the source does not—he may assume, but he cannot be certain. This gives the interrogator a distinct<sup>6</sup> advantage.
- Having gained the initial advantage, the interrogator must strive to maintain

the initiative by applying appropriate interrogation techniques through exercise of self-control; by taking advantage of the source's weaknesses as they become apparent; and by continuously displaying an attitude of confidence and self-assurance. The interrogator, however, must never take advantage of the source's weaknesses to the extent that the interrogation involves threats, insults, torture or exposure to unpleasant or inhumane treatment of any kind.

■ It is possible for an interrogator to lose the initiative during interrogation of a source. If this should occur, postponement of the interrogation and a reassessment of the situation is advisable. If the interrogation is resumed, it might be advantageous to introduce a different interrogator. Following are some examples of loss of initiative:

- ① The interrogator becomes angry and completely loses his composure and self-control because of the arrogant actions of the source. As a result, the interrogator loses sight of his objective and concentrates his efforts on humbling the source.
- ② During the interrogation the interrogator fails to note significant discrepancies in the source's story. The interrogator may lose the initiative as the source gains confidence from his success and resorts to further deception, leading the interrogator away from the objective of the interrogation.
- ③ The interrogator becomes overly friendly with the source and allows him to lead the interrogation. The source reports only what he believes to be important and neglects several significant items of information which could have been obtained had the interrogator maintained the initiative.

## Accuracy

The interrogator must make every effort to obtain accurate information from the source. He must be certain that he understands the source correctly by repeating questions at varying intervals. The interrogator, however, is not the final analyst and should not reject or degrade information because it conflicts with previous information. The interrogator's primary mission, is collection of information, not evaluation. Conversely, the interrogator should not accept all information as the truth; he must view all information with skepticism and, to the extent his capability and time permit, should attempt to confirm or deny information received. Of great importance is the accurate reporting of information to the using elements. The interrogator must check his notes against the finished report to insure that they contain and identify appropriately the information as heard, seen, or assumed by the source.

## Prohibition Against Use of Force

■ The use of force, mental torture, threats, insults or exposure to unpleasant and inhumane treatment of any kind as an aid to interrogation is prohibited by law and is not authorized or condoned by the United States Army. Experience indicates that the use of force is not necessary to gain cooperation of sources for interrogation. Use of force is a poor technique, yields unreliable results, may damage subsequent collection efforts, and can induce the source to say what he thinks the interrogator wants to hear. However, the use of force is not to be confused with psychological ploys, verbal trickery, or other nonviolent and noncoercive ruses used by the interrogator in the successful interrogation of hesitant or uncooperative sources.

■ The psychological techniques and principles outlined in this manual should neither be confused with, nor construed to be synonymous with, unauthorized techniques such as "brainwashing," mental torture, or any other form of mental coercion to include drugs that may induce lasting and permanent mental alteration and damage. In this regard, it should be noted that historically:

- ④ "Brainwashing" involves the conditioning of a source's Stimulus-Response Bond through methods such as, but not limited to, sensory deprivation, indoctrination, group dynamics, or combinations thereof. The objective of this procedure is directed

primarily towards the source's acceptance and adoption of beliefs, behavior, or doctrine alien to his native cultural environment for propaganda rather than intelligence collection purposes.

☉ Mental torture and coercion revolve around eliminating the source's "Free Will" and are explicit violations of Article 17, Geneva Conventions Relative to the Treatment of Prisoners of War (GPW). Precedence indicates that mental torture or coercion involves using force or violence, or other threats to gain a source's cooperation. When violence is threatened, the source has to choose between cooperating with those in authority and having force (including death and/or dismemberment) applied to himself or his family. However, for the threat of violence to become effective, the authority must apply violence to substantiate his threats. In most instances, the actual use of physical violence precludes the exercise of "Free Will" by the source in choosing between the available alternatives.

■ The techniques and principles contained within this manual are intended to serve as guides in obtaining the willing cooperation of a source; and the absence of the use of threats in interrogation is intentional, as their enforcement and use normally constitute violations of international law and may result in prosecution under the Uniform Code of Military Justice. Additionally, the inability to carry out a threat of violence or force renders an interrogator ineffective should the source challenge the threat. Consequently, from both legal and moral viewpoints, the restrictions established by international law, agreements, and customs render threats of force, violence, and deprivation useless as interrogation techniques.

## Security

The interrogator, by virtue of his position, possesses much classified information. He constantly must be aware that his job is to obtain information, not impart it to the source. The necessity for safeguarding military information is an ever-present and ever-important requirement. This becomes very clear when one considers that among those persons with whom the interrogator has contact there will be those attempting to collect information for the enemy. The interrogator must be alert to detect any attempt to elicit information from him.

## The Interrogator

### General

The use of properly qualified and thoroughly trained interrogators is a fundamental requirement for the efficient exploitation of human and material sources which are of potential intelligence interest. These interrogators are found in military intelligence units. Interrogators are selected for their personal qualities and special skills and abilities.

### Personal Qualities

The obvious personal qualities which an interrogator should possess are an interest in human nature and suitable personality characteristics which will enable him to gain the cooperation of a source to be interrogated. Ideally, these and other personal qualities would be inherent in an interrogator; however, in most cases an interrogator can correct some deficiencies in these qualities if he has the desire and is willing to devote much time to study and practice. Some of the personal qualities desirable in an interrogator are:

■ **Motivation.** An interrogator may be motivated, for example, by interest in human relations, intellectual curiosity, a desire to react positively to the challenge of personality interplay, or an enthusiasm for the collection of information. Whatever the motivation, it is the most significant factor in the success achieved by an interrogator. Without motivation other qualities lose their significance. The stronger the motivation, the more successful the interrogator. The mental attitude of an interrogator is actually a part of motivation. An interrogator must approach each interrogation as a separate entity. He should look forward to starting the interrogation and must be confident that the source will

cooperate. He must have the will to do a good job. Such an attitude on the part of the interrogator will be felt by the source and will increase the chances of cooperation.

■ **Alertness.** The interrogator must be constantly aware of the shifting attitudes which normally characterize a source's reaction to interrogation. The interrogator must note the source's every gesture, word, and voice inflection. Is the source angry, frightened, light-hearted, talkative, sullen, vague, straightforward, at ease, cooperative, worried, nervous, sincere? If the source is angry, why is he angry? Is it because he resents being interrogated, or is it because he was captured? There may be other reasons. The interrogator must attempt to determine why the source is in a certain mood or why his mood suddenly changed. It is from the source's mood and actions that the interrogator can best determine how to proceed with the interrogation. The interrogator must watch for any indication that the source is withholding additional information. He must watch for a tendency to resist further questioning, for diminishing resistance, for contradictions or other tendencies.

■ **Patience and Tact.** These qualities in an interrogator assist in creating and maintaining a favorable atmosphere between himself and the source, thereby enhancing the success of the interrogation. The validity of a source's statements and the motives behind these statements may be obtainable only through the exercise of tact and patience. Displaying impatience encourages the difficult source to think that if he remains unresponsive for a little longer, the interrogator will stop his questioning. The display of impatience may cause the source to lose respect for the interrogator, thereby reducing his effectiveness. An interrogator displaying patience and tact will be able to terminate an interrogation and to reinstitute further interrogation without having aroused apprehension or resentment.

■ **Credibility.** The interrogator must maintain credibility with the source. Failure to produce material rewards when promised may adversely affect future interrogations. Likewise, the importance of honest reporting cannot be overstressed, since interrogation reports are often used as a basis for tactical decisions and operations.

■ **Objectivity.** The interrogator must have the ability to maintain a dispassionate mental attitude regardless of the emotional reactions he may actually experience or which he may simulate during the interrogation. Without this required objectivity, the interrogator may unconsciously distort the information acquired and may be unable to vary his interrogation techniques effectively.

■ **Self-Control.** An exceptional degree of self-control is required by the interrogator to avoid displays of genuine anger, irritation, sympathy, or weariness which may cause him to lose the initiative during the interrogation. This quality is especially important when employing interrogation techniques which require the display of simulated emotions or attitudes.

■ **Adaptability.** An interrogator must be able to adapt himself to the many and varied personalities which he will encounter. He should try to imagine himself in the source's position. By being able to so adapt, the interrogator can smoothly shift his techniques and approaches during interrogations. The interrogator must also be able to adapt himself to the operational environment. Interrogators will, in many cases, be required to function effectively under a variety of unfavorable physical conditions.

■ **Perseverance.** A tenacity of purpose, in many cases, will make the difference between an interrogator who is merely good and one who is superior. An interrogator who becomes easily discouraged by opposition, noncooperation, and other difficulties, will neither aggressively pursue the objective to a successful conclusion nor seek leads to other valuable information.

■ **Appearance and Demeanor.** The personal appearance and behavior of the inter-

rogator may influence, to a great degree, the conduct of the interrogation and the attitude of the source toward the interrogator. A neat, organized, and professional appearance will favorably influence the source. A firm, deliberate, and businesslike manner of speech and attitude will create a proper environment for the conduct of a successful interrogation. If the interrogator's personal manner reflects fairness, strength, and efficiency, the source may prove cooperative and more receptive to questioning.

## Special Skills and Abilities

The interrogator must possess, or acquire through training and experience, a number of special skills and knowledge.

■ **Knowledge of Interrogation Techniques.** Specific interrogation techniques applicable to all forms of interrogation are discussed in chapter 2.

■ **Understanding of Basic Psychology.** An interrogator can best adapt himself to the source's personality and control his own reactions when he has an understanding of basic psychological factors, traits, attitudes, drives, motivations, and inhibitions. For example, the timely use or promise of rewards and incentives may mean the difference between success or failure of an interrogation and future exploitation of the source.

## Interrogator Training

Training in intelligence interrogation consists of specific instruction in the provisions of the Geneva Conventions of 12 August 1949, and in the general principles of the law of land warfare. Emphasis should be given to the practical application and benefits of lawful interrogation procedures as outlined in this manual. Additional training should be given to further this knowledge and improve special skills listed and discussed in the previous paragraph. It is important that the interrogator be well versed in US forces organization, tactics, techniques, equipment, and related subjects so that he can judge the relative significance of information a source may impart to him.

# SECTION IV. The Source

## General

The types of persons an interrogator encounters will vary greatly in personality, social class, civilian occupation, military specialties, and political and religious beliefs. Their physical conditions may range from near death to perfect health, their mental abilities may range from well below average to well above average, and their security consciousness may range from the lowest to the highest. Sources may be civilian internees, enemy prisoners of war, defectors, refugees, displaced persons, agents or suspected agents, or other non-US personnel. Because of these variations, the interrogator must make a careful study of every source to obtain an evaluation of his character and use it as a basis for interrogation.

## Categories of Sources

From the standpoint of attitude toward the interrogator or toward the act of interrogation itself, sources fall into the three broad categories described below.

■ **Cooperative and Friendly.** A cooperative and friendly source offers little resistance to the interrogation, and normally will speak freely on almost any topic broached, other than on that which will tend to incriminate or degrade him personally. To secure the maximum value from this type of source, the interrogator must take care to establish and to preserve a friendly and cooperative atmosphere by not inquiring into those private affairs of the source which are beyond the scope of the interrogation. At the same time, he must avoid becoming overly friendly and losing control of the interrogation.

■ **Neutral and Nonpartisan.** A neutral and nonpartisan source is cooperative to a limited degree. He normally takes the position of answering questions asked directly, but seldom volunteers information. In some cases he may be afraid to answer for fear of reprisals by the enemy. This often is the case in a conflict involving irregular forces, or in

internal defense operational environments, where the people may be fearful of insurgent reprisal should they cooperate with government forces or submit to interrogation or questioning. With the neutral and nonpartisan source, the interrogator may have to ask many specific questions to obtain the information required.

■ **Hostile and Antagonistic.** A hostile and antagonistic source offers the most difficult interrogation problem. In many cases he will refuse to talk at all and will offer a real challenge to the interrogator. The exercise of self-control, patience, and tact are particularly important when dealing with him. As a rule, it is considered unprofitable to expend excessive time and effort in interrogating hostile and antagonistic sources at the lower echelons. When time is available and the source is an excellent target for exploitation, he should be isolated and repeatedly interrogated to obtain his cooperation. A more concentrated interrogation effort can be accomplished at higher levels.

## Chapter 2 THE INTERROGATION PROCESS

### General

#### Basic Types of Interrogation

This chapter considers the basic types of interrogation, the phases of an interrogation, the techniques of approach and questioning, the psychological aspects of interrogation, and the use of the polygraph.

Interrogation normally takes two general forms—direct interrogation and indirect interrogation. The distinction between the two lies primarily in the source's awareness of the fact that he is being interrogated.

■ **Direct Interrogation.** In the direct form of interrogation, the source is aware of the fact that he is being interrogated, but he may or may not learn the true objective of the interrogation. This method may be likened to a cross-examination of a witness in a court of law in that every ethical and legal advantage is taken by the interrogator. An advantage of the direct form of interrogation is that it is less time consuming, and, for this reason, it is the most frequently used method. The direct form of interrogation is used in almost all EPW interrogations, from the preliminary screening in combat areas and occupied zones to the detailed and methodical questioning of suspected enemy agents. An example of the direct form of interrogation would be the questioning of an EPW about his military history. He may or may not learn that the specific information wanted by the interrogator is the location of the EPW's present unit headquarters. Also included in the direct form of interrogation is the interview.

■ **Indirect Interrogation.** This form of interrogation is characterized by obtaining information through deception. The task of the interrogator is to extract the maximum amount of usable information from a source without his realizing that he is under interrogation. This form of interrogation requires careful planning, extreme discretion, and skillful application; only the skilled and experienced interrogator can employ this method with success. An example of this form of interrogation could be the disguising of the interrogator as a guard in an EPW compound; by becoming friendly with EPW, the interrogator is able to elicit information through idle conversation. This method is more frequently employed at higher echelons with selected sources who are thought to possess valuable information.

Both types of interrogation, direct and indirect, may be used at either the tactical or strategic levels of intelligence. At a tactical level, information of immediate use to the combat commander is normally the goal, and due to time limitations, direct interrogation is usually more feasible. At a strategic level, the goal is detailed information concerning

(for example) the enemy country's capabilities to wage continued hostilities. The use of either direct or indirect interrogation will be dependent upon the time available to conduct the interrogation, the capabilities of the interrogator, and the particular circumstances and disposition of the source.

## Selection of Sources

Criteria for the selection of personnel to be interrogated vary with the nature of the information sought, time limitations, number and types of potential sources available, and the exact circumstances surrounding the employment of US Forces. In this regard, the selection of sources is particularly important in conducting interrogations at tactical echelons of command, because of the proximity to enemy elements, the number and conditions of detainees, and time restrictions.

## Phases of Interrogation

### Planning and Preparation Phase

■ **General.** Each interrogation requires considerable advance planning and preparation if it is to succeed. To have the interrogator prepare himself adequately, it is incumbent upon the person(s) who capture, take into custody, or guard the source to report all pertinent information, orally or in writing, on the circumstances of the capture or seizure and on the attitude, behavior, and treatment of the source during custody. The captive tag is the common method of providing data on a detainee. Oral or written reports must be made available to the interrogator unless their importance requires other disposition.

■ **Planning Consideration.** Every interrogator must continuously plan and prepare himself by keeping abreast of current events, the local and world situation, and the latest interrogation aids and techniques, and by practicing the techniques and languages. Many unsuccessful interrogations result from inadequate planning and preparation. In addition to the above, the interrogator must consider the following factors when preparing for an interrogation:

- ① **Specialized Background Knowledge.** The interrogation may require that the interrogator conduct research to obtain detailed background data on a specific geographic area, political group, weapons system, or technical field. In the technical field, technical intelligence personnel will be able to assist the interrogator. There are various weapons identification guides to assist the interrogator in identifying any weapons mentioned by source. However, the source should not be shown this guide until he has thoroughly described the item(s) or has drawn a picture of the weapon(s).
- ② **Assessment of Source.** The interrogator must collect, study, and evaluate all information available on the source to be interrogated. This procedure may range from a brief examination of a capture tag by an interrogator at the lowest tactical level, to a lengthy analysis of voluminous investigative files compiled by intelligence specialists. In addition to this background data, a visual observation of the source immediately prior to the interrogation may reveal a physical or psychological weakness which could be exploited during interrogation operations.
- ③ **Interrogation aids.** The interrogator may require maps, documents, recording equipment, photographic equipment, and other aids to facilitate the conduct of the interrogation. From these aids, he must select those best suited to accomplish the objective, determine their availability, and arrange for their procurement well in advance of the interrogation.



## Approach Phase PRINCIPLES OF INTERROGATION From last issue

■ **General.** The approach phase begins with the initial contact between the source and the interrogator. Extreme care is required, since the success of the interrogation hinges, to a large degree, on the early development of a willingness on the part of the source to communicate. The objective of the interrogator during this phase is to establish rapport with the source and thus gain his cooperation so that he will correctly answer the pertinent questions to follow. The interrogator adopts an appropriate attitude, based on his appraisal of the source; prepares for a change in attitude if necessary; and begins to employ an approach technique. The amount of time spent on this phase will depend on such factors as the probable quantity and value of information the source possesses, the availability of other sources with knowledge of the same topics, and the time available. At the initial contact, a businesslike relationship should be maintained. As the source assumes a cooperative attitude, a more relaxed atmosphere may be advantageous. The interrogator must carefully determine which of the various approach techniques he will employ. The approach technique chosen by the interrogator will depend on the physical and/or mental state of the source, the mission and objectives of the interrogator, the background knowledge of the source, and the interrogator himself.

Regardless of the type of source and his outward personality, he does possess weaknesses which, if recognized by the interrogator, can be exploited. These weaknesses are manifested in personality traits such as speech mannerisms, facial expressions, physical movements, excessive perspiration, and other overt indications, and will vary from source to source. From a psychological standpoint, the interrogator must be cognizant of the following behavioral principles which he can use in interrogations. A human being is likely to:

- ① Talk, especially after harrowing experiences.
- ② Show deference when confronted by superior authority.
- ③ Rationalize acts about which he feels guilty.
- ④ Lack the ability to apply or to remember lessons he may have been taught regarding security if confronted with a disorganized or a strange situation.
- ⑤ Cooperate with those who have control over him.
- ⑥ Attach less importance to a topic about which the interrogator demonstrates identical or related experiences and knowledge.
- ⑦ Appreciate flattery and exoneration from guilt.
- ⑧ Resent having something or someone he respects belittled, especially by someone he dislikes.
- ⑨ Respond to kindness and understanding during trying circumstances.
- ⑩ Cooperate readily when given material rewards such as money, or luxury items for his personal comfort.

■ **Techniques.** The techniques outlined below are not new by any means, nor are all possible or acceptable techniques discussed. The variety of techniques is limited only by the initiative, experience, imagination, and ingenuity of the interrogator. Some techniques which have proven effective are:

- ① **"Direct Approach" technique.** The interrogator makes no effort to conceal the purpose of the interrogation. It is best employed when the interrogator believes the source will offer little or no resistance. It is also suitable with sources who have had little or no security training. The advantages of this technique are its simplicity and the fact that it takes little time. Experience has

proved this technique to be very effective with low-level EPW, because such EPW will normally cooperate with little persuasion. For this reason, it is frequently used at the lower tactical echelons where time is limited.

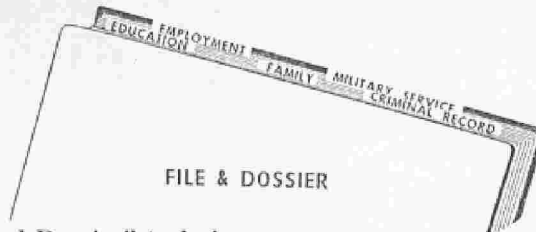

- ④ **"File and Dossier" technique.** The interrogator prepares a dossier containing all available information obtained from records and documents concerning the source or his organization. Careful arrangement of the material within the file may give the illusion that it contains more data than is actually there. The file may be "padded" with extra paper, if necessary. Index tabs with titles such as "education," "employment," "criminal record," "military service" and others are particularly effective for this purpose. The interrogator confronts the source with the dossier at the beginning of the interrogation and explains to him that "intelligence" has provided a complete record of every significant happening in the source's life; therefore, it would be useless to resist interrogation. The interrogator may read a few selected bits of known data to further impress the source. If the technique is successful, the source will be impressed with the "voluminous" file, conclude that everything is known, and resign himself to complete cooperation during the interrogation. The success of this technique is largely dependent on the naivete of the source, the volume of data on the subject, and the skill of the interrogator in convincing the source.

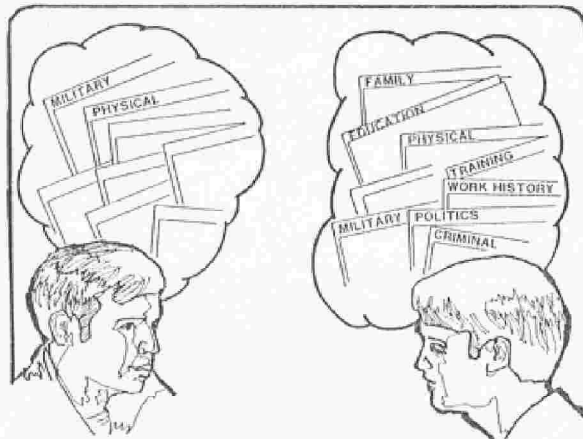

- ⑤ **"We Know All" technique.** This technique may be employed in conjunction with the "File and Dossier" technique or by itself. The interrogator must first become thoroughly familiar with the available data concerning the source. To begin the interrogation, the interrogator asks questions based on this known data. When the source hesitates, refuses to answer, or provides an incomplete or

incorrect reply, the interrogator himself provides the detailed answer. Through the careful use of the limited number of known details, the interrogator may convince the source that all information is already known; therefore, the source's answers to the questions are of no consequence. When the source begins to give accurate and complete information, the interrogator interjects questions designed to gain the needed information. Questions to which answers are already known are also asked to test the source and to maintain the deception that all the information is already known.



⊙ **"Futility" technique.** In this approach, the interrogator convinces the source that resistance to questioning is futile. Factual information is presented by the interrogator in a persuasive, logical manner. When employing this technique, the interrogator must not only be fortified with factual information, but he should also be aware of, and be able to exploit, the source's psychological and moral weaknesses as well as weaknesses inherent in his society.

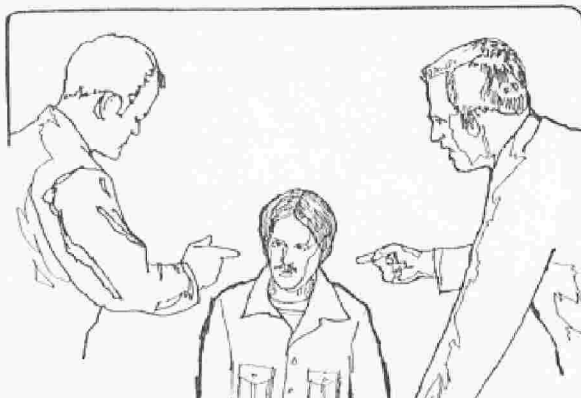

⊙ **"Rapid Fire" technique.** This approach technique involves a psychological ploy based upon the principles that:

- Everyone likes to be heard when he speaks; and
- It is confusing to be interrupted in mid-sentence with an unrelated question. This technique may be used by an individual interrogator, or simultaneously by two or more interrogators in questioning the same source. In

employing this technique the interrogator asks a series of questions in such a manner that the source does not have time to answer a question completely before the next question is asked. This tends to confuse the source and he is apt to contradict himself, as he has little time to prepare his answers. The interrogator then confronts the source with the inconsistencies, causing further contradictions. In many instances, the source will begin to talk freely in an attempt to explain himself and deny the inconsistencies pointed out by the interrogator. In attempting to explain his answers, the source is likely to reveal more than he intends, thus creating additional leads for further interrogation. The interrogator must have all his questions prepared before approaching the source, because long pauses between questions allow the source to complete his answers and render this approach ineffective. Besides extensive preparation, this technique requires an experienced, competent interrogator, who has comprehensive knowledge of the case, and fluency in the language of the source. This technique is most effective immediately after capture, because of the confused state of the source.



● **"Incentive" technique.** This approach technique is based on the application of indirect physical discomfort upon a source who is hostile and lacks will power. The source may display fondness for certain luxury items; e.g., candy, fruit, tobacco, etc. This fondness provides the interrogator with a positive means of rewarding the source for cooperation and truthfulness, as he may give or withhold such comfort items at his discretion. Caution must be used in employing this technique because:

- Any pressure applied in this manner must not under any circumstances amount to a denial of basic human needs.
- The source might be tempted to provide false or inaccurate information to gain the luxury item he desires or to stop the interrogation.

● **"Repetition" technique.** Repetition is used to induce cooperation from a hostile source. In one variation of this technique the interrogator listens carefully to a source's answer to a question, and then repeats both the question and answer several times. He does this with each succeeding question until the source becomes so thoroughly bored with the procedure that he answers questions fully and candidly to satisfy the interrogator and to gain relief from

# REPETITION

## REPETITION

UNIT-POSITION

### REPETITION

NAME-UNIT-POSITION

the monotony of this method of questioning. The repetition technique must be used carefully, as it will generally not work when employed against introverted sources or those having great self-control. In fact, it may provide an opportunity for a source to regain his composure and delay the interrogation. In employing this technique, the use of more than one interrogator or a tape recorder has proven to be effective.

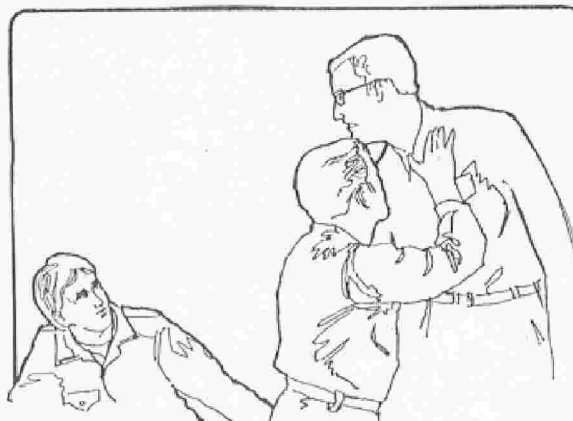

- **"Mutt and Jeff" technique.** (This technique might also be called "Friend and Foe.") This technique involves a psychological ploy which takes advantage of the natural uncertainty and guilt which a source has as a result of being detained and questioned. Use of this technique necessitates the employment of two experienced interrogators who are convincing actors. Basically, the two interrogators will display opposing personalities and attitudes toward the source. For example, the first interrogator is very formal and displays an unsympathetic attitude toward the source. He might be strict and order the source to follow all military courtesies during questioning. The goal of the technique is to make the source feel cut off from his friends. At the time the source acts hopeless and alone, the second interrogator appears (having received his cue by a signal, hidden from the source, or by listening and observing out of view of the source), scolds the first interrogator for his harsh behavior and orders him from the room. He then apologizes to soothe the source, perhaps offering him coffee and a cigarette. He explains that the actions of the first interrogator were largely the result of an inferior intellect and lack of human sensitivity. The inference is created that the second interrogator and the source have in common a high degree of intelligence and an awareness of human sensitivity, above and beyond that of the first interrogator.

The source is normally inclined to have a feeling of gratitude towards the second interrogator, who continues to show a sympathetic attitude towards the source in an effort to increase the rapport and control for the questioning which will follow. Should the source's cooperativeness begin to fade, the second interrogator can hint that since he is of high rank, having many other duties, he cannot afford to waste time on an uncooperative source. He may broadly infer that the first interrogator might return to continue his questioning. When used against the proper source, this trick will normally gain the source's complete cooperation for interrogation.

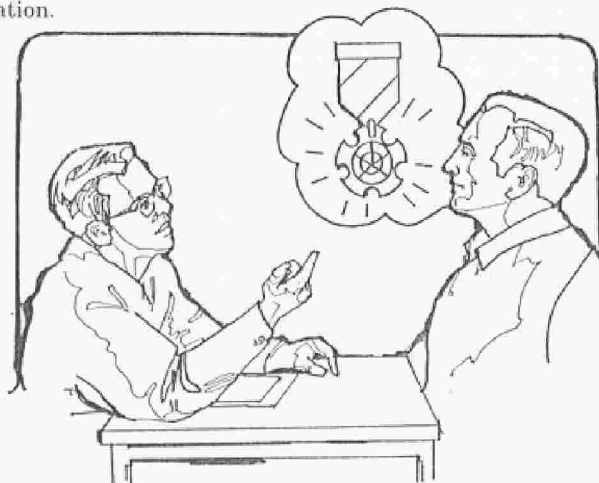

⊙ **"Pride and Ego" technique.** The strategy of this technique is to trick the source into revealing desired information by goading or flattering him. It is effective with sources who have displayed weaknesses or feelings of inferiority. A real or imaginary deficiency noted about the source, his loyalty to his organization, or any other feature can provide a basis for use of this technique. The interrogator accuses the source of weakness or implies that he is unable to do a certain thing. The proud or egotistical source will jump to the defensive. This type of source is also prone to make excuses and give reasons why he did or did not do a certain thing, often shifting the blame to others. An example is the interrogator opening the interrogation with the question, "Why did you surrender so easily when you should have escaped by crossing the nearby ford in the river?" The source is likely to provide a basis for further questions or to reveal significant intelligence information if he attempts to explain his surrender in order to vindicate himself with an answer such as, "No one could cross the ford because it is mined."

This technique may also be employed in another manner—by flattering the source into admitting certain information in order to gain credit. For example, while interrogating a suspected saboteur, the interrogator states, "This sure was a smooth operation. I have seen many previous attempts fail. This was really done with finesse. I bet you planned this; who else but a clever fellow like you could have planned it? When did you first decide to do the job?" This technique is especially effective with the rather stupid source who has always been looked down upon by his superiors. It provides the source with the opportunity to show someone that he has "brains."

⑤ **"Silent" technique.** This technique may be successful when employed against either the nervous, or the confident-type source. When employing this technique, the interrogator says nothing to the source, but looks him squarely in the eye, preferably with a slight smile on his face. It is important not to look away from the source, but force him to break eye contact first. The source will become nervous, begin to shift around in his chair, cross and recross his legs, and look away. He may ask questions, but the interrogator should not answer until he is ready to break the silence. The source may blurt out questions such as, "Come on now, what do you want with me?" When the interrogator is ready to break silence, he may do so with some quite nonchalant questions such as, "You planned this operation a long time, didn't you? Was it your idea?" The interrogator must be patient when employing this technique. It may appear for a while that the technique is not succeeding, but it usually will when given a reasonable chance.

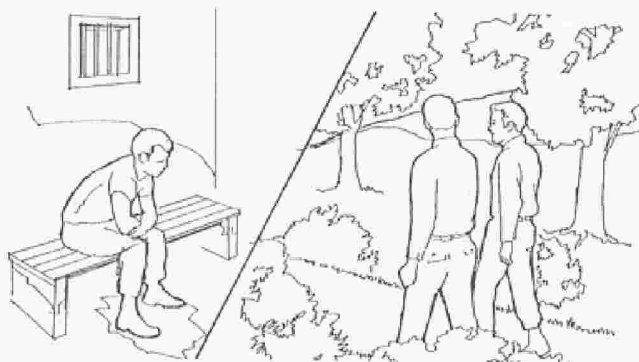

⑥ **"Change of Scene" technique.** The idea in using this approach is to get the source away from the atmosphere of an interrogation room or setting. If the interrogator confronts the type source who is very apprehensive or frightened because of the environment of an interrogation, this technique may well prove effective. In some circumstances, the interrogator may be able to invite the source to a nearby coffeehouse (it must be a setting which the interrogator can control) for coffee and pleasant conversation. During the conversation in this more relaxed environment, the interrogator steers the conversation to the topic of interest. Through this somewhat indirect method, he will attempt to elicit the desired information. The source may never realize that he is being "interrogated." Another example is an interrogator posing as a guard (the source a prisoner), engaging the source in conversation, and thus drawing out the desired information. This technique requires skill and patience on the part of the interrogator.

⑦ **"Establish Your Identity" technique.** This technique is especially adaptable to the interrogation of EPW. The interrogator insists that the EPW has been correctly identified as an infamous individual wanted by higher authorities on very serious charges, and that he is not the person he purports to be. In an effort to clear himself of this allegation, the source will make a genuine and detailed effort to establish or substantiate his true identity. In so doing, he may provide the interrogator with information and leads for further development.

⑧ **"Emotional" technique.** This technique provides the interrogator with valuable assistance in convincing a source to cooperate. Through observation of the source, the interrogator can often identify the dominant emotions which





motivate the individual. The motivating emotion may be greed, love, hate, revenge, or one of many other human emotions. The interrogator employs verbal and emotional ruses in applying pressure to the source's dominant emotion or emotions. One major advantage of this technique is its versatility which allows the interrogator to use the same basic situation, either positively or negatively. For example, this technique can be used on the EPW who has a great love for his unit and fellow soldiers. The interrogator may take advantage of this by telling the source that his providing information may shorten the war or battle in progress and save many of his comrades' lives, but that his refusal to talk may cause their deaths. This places a burden on the source and may motivate him to seek relief through cooperation. Conversely, this technique can also be used on the prisoner who hates his unit because it withdrew and left him to be captured, or on one who perhaps feels that he was treated unfairly in his unit. In such cases, the interrogator can point out that if the source cooperates and points out the location of the unit, the unit can be destroyed, thus giving the source an opportunity for revenge. The interrogator proceeds with this method in a very formal manner. This approach is likely to be effective with the immature and timid source and should be employed only by an experienced interrogator.



■ **Use of Several Techniques.** It may be necessary for the interrogator to use several approach techniques concurrently, or in succession, with individual sources.

In this context, the interrogator should decide during the planning phase which of the techniques might work well together, and be prepared for a transition from one technique into another as the source's personal characteristics and weaknesses become apparent during the approach phase. Several of the approach techniques complement each other and can easily be orchestrated together. For example, the "File and Dossier," "Futility," and "We Know All" approaches work well together in obtaining a source's cooperation.

## Questioning Phase

■ **General.** Although there is no fixed point at which the approach phase ends and the questioning phase begins, generally the questioning phase commences when the source begins to answer questions pertinent to the specific objectives of the interrogation. Questions should be comprehensive enough to insure that the topic of interest is thoroughly explored. Answers should be obtained to establish the who, what, when, where, why, and how. Questions should be presented in a logical sequence to be certain that significant topics are not neglected. A series of questions following a chronological sequence of events is frequently employed, but this is by no means the only logical method of asking questions. Adherence to a sequence should not deter the interrogator from exploiting informational leads as they are obtained. The interrogator must consider the probable response of the source to a particular question or line of questioning and should not, if at all possible, ask direct questions likely to evoke a refusal to answer or to antagonize the source. Experience has shown that in most tactical interrogations, the EPW is cooperative; in such instances, the interrogator should proceed with direct questions.

■ **Types of Questions.** The manner of questioning and the nature of the questions will be based on the mission and the situation. The following general guidelines are applicable to the questioning phase:

● **Prepared questions.** When the topic under inquiry is particularly technical or when the legal aspects of the interrogation require preciseness, the interrogator should have a list of prepared questions to follow during the interrogation. In other cases where the interrogator will touch on several fields of interest, it may be desirable to prepare an interrogation guide or outline to insure that all topics are explored. In the use of prepared questions or interrogation guides, the interrogator must be careful to avoid restricting the scope and flexibility of the interrogation.

● **Control questions.** To maintain control and to check on the truthfulness of the source, the normal questions should be mixed with control questions—those with known answers. Failure to answer these questions or wrong answers indicates that the source may not be knowledgeable on the topic or that his answers to other questions are also false.

● **Nonpertinent questions.** Frequently, it may be desirable, or even mandatory, that the true objective of the interrogation be concealed from the source. By carefully blending pertinent with nonpertinent questions, the interrogator can conceal the true purpose of the inquiry and lead the source to believe that some relatively insignificant matter is the basis for the interrogation by asking pertinent questions in a casual manner; stressing questions and details which are not important; and dwelling on nonpertinent topics which the source appears reluctant to discuss. The source may be reluctant to discuss the matter of interest, but quite willing to discuss more pleasant things. The interrogator may relax the source by first discussing irrelevant topics using nonpertinent

questions, then switching back to pertinent questions for desired information. Another use of nonpertinent questions is to break the "train of thought" of the source. This is of particular importance if it is suspected that the source is lying. Since a person must concentrate to lie effectively, the interrogator can break this concentration by suddenly interjecting a completely unrelated question, then switching back to the pertinent topic.

● **Repeated questions.** As a means of insuring accuracy, particularly when the interrogator suspects that the source is lying, questions should be repeated at varying intervals. Since a lie is more difficult to remember than the truth, especially when the lie has been composed on the spur of the moment, the interrogator can establish errors by rephrasing and disguising the same questions which the source has already answered. Repetition also serves to insure accuracy on points of detail, such as places, names, dates, component parts of technical equipment, and similar topics.

● **Direct and leading questions.** The manner in which questions are worded has a direct bearing on the source's response. A question may be posed in a number of ways. For example:

- "Where did you go last night?"
- "Did you go to the headquarters last night?"
- "You did go to the headquarters last night?"
- "You did not go to the headquarters last night, did you?"

The first example is a simple direct question which requires a narrative reply. Such an answer usually produces the maximum amount of information and provides a greater number of leads which can be followed up by the interrogator. The other three examples are leading questions in that they suggest the answers. The source merely answers "yes" or "no." Leading questions tend to prompt the source to give the reply he believes the interrogator wants to hear and to limit the amount of detail in the reply. As a general rule, leading questions do not serve the purpose of interrogation—to obtain complete and accurate information. This does not mean, however, that leading questions should always be avoided by the interrogator. They can be used very effectively as a means of verification, as a means of strategy, or as a means of pinpointing specific details.

● **Compound questions.** Compound questions normally should be avoided, because they are easily evaded and sometimes hard to understand. An example of a compound question is: "What type of training did you receive at opposing forces basic training center and what type of training did you receive later at opposing forces advanced training center?" The source may answer both, only one, or neither one; the answer received may be ambiguous, incomplete, or both. Definitive answers to compound questions seldom are received.

● **Negative questions.** The interrogator should avoid asking negatively phrased questions, because they are confusing and may produce misleading or false information. Suppose for a moment that the interrogator poses a question such as this: "You do not know whether Smith went to the headquarters last night?" The reply is "Yes." Does the source intend to say, "Yes, I know," or did he mean, "Yes, it is true that I do not know," or did he mean, "Yes, Smith was there?" If the ambiguity is caught at the moment that the answer is received, another question can be asked to clarify the doubt. If the interrogator fails to note the negative question, in all probability he will elicit an answer that the source never meant to give. In either case, the delay or the resulting loss of an

important point detracts from the effectiveness of the interrogation.

● **Brief and precise questions.** All questions should be brief and to the point. There should be no doubt in the source's mind as to what the interrogator wants to know. If the source cannot understand the question, he certainly cannot be expected to answer it. And if he does answer it, the answer may lead the interrogator to arrive at a wrong conclusion.

● **Simply worded questions.** All questions should be simple. Avoid big words. This is especially important when using an interpreter; for even with simple words and questions, the complexities of language and normal translation difficulties pose enough of a communication problem.

● **Follow-up questions.** During the interrogation, the source may make statements indicating that he has information of intelligence value other than that which is the objective of the current interrogation. He also may mention other persons who may be profitably interrogated. These leads may appear while the source is telling a story or replying to a question. Leads frequently appear in compound answers to simple and direct questions, as shown in the following example: The interrogator asks, "Where did you go on 22 June?" The source replies, "I drove home to Centerville to borrow some money from my brother, Joe." The interrogator's question asked only "where" but he learned not only "where" but "why" and "who" was contacted. Thus, several new avenues of questioning have been opened. The interrogator must remain alert to detect and exploit these leads with further questions; but in doing so, he must exercise caution to insure that the source does not deliberately introduce obviously inviting leads as a means of evading the topic under inquiry at the moment.

#### ■ **Topical Sequence.**

● **Topics.** Normally, the first topic for questioning should be concerned with determining the current duties performed by the source. This information will give the interrogator an important clue to the general knowledge the source is likely to possess and will provide the bridge to the next question.

● **Source's mission.** Clues obtained from the duties of the source will help the interrogator to determine the source's mission just prior to capture. This information will also aid the interrogator in determining the missions of the EPW or source's agency or unit and those of related units.

● **Immediate area information.** The source will be most familiar with the activities, locations, installations, or troop dispositions of his own unit and those within his immediate area. He is best qualified to speak about the activities in which he was personally engaged or observed.

● **Adjacent area information.** The source may be able to provide additional information about adjacent areas. This will enable the intelligence officer or other using agency to draw conclusions concerning other sectors of the enemy front.

● **Supporting information.** Everything the source contributes to the overall situation should be reported. This includes locations, deployment, activities of supporting units, and information regarding installations and weapons in the area. It also includes the names of all commanders and other persons known to the source.

□ **Fantasy.** This escape mechanism is commonly known as daydreaming. Individuals with little to do, such as prisoners, tend to daydream more than other persons; this sometimes presents a problem to the interrogator. He must be careful when interrogating a shy source or a source who may have been a prisoner for some time. After a source has imagined something for a long period of time, it often becomes fact to him, which creates for the interrogator the problem of separating fact from fantasy.

□ **Negativism.** The source reaches the point where he refuses to cooperate in any manner or does just the opposite of what is asked. Usually, a source will reach this state after he has been under restraint for a period of time and has worked himself into a high emotional pitch of resentment, hostility, and fear. When confronted with this type of escape mechanism, the interrogator should approach the prisoner by trying to lessen his fears, hostility, and resentment, and by affording him some type of security. He should try to minimize the interrogator-source relationship and offer encouragement and reassurance.

□ **Regression.** The source may retreat to earlier developmental stages in his life—in extreme cases, even to early childhood. The unconscious reason for such regression is to escape responsibility or reality. The source who is fearful of the consequences of the interrogation, or lacks faith in his own ability to withstand interrogation, may resort to regression to escape reality and the responsibility of facing the interrogator. In many cases, the interrogator can reestablish the source in his adult role and gain his cooperation by using a reasonable, sympathetic, and friendly approach. In extreme cases, the interrogator may have to use a “parent to child” approach to obtain pertinent information from the source.

□ **Repression.** Repression is not a deliberate mechanism employed by individuals, but an involuntary action which tends to blot events from the memory, or deny past happenings. It especially affects memories of events which were violent, repulsive, illegal, or shameful. It is an unconscious effort of the individual who has feelings of guilt, shame, or loss of self-esteem. This mechanism was encountered quite frequently after World War II by interrogators among sources who had participated in, or were associated with, atrocities. When the interrogator encounters this type of escape mechanism, it may be necessary for him to assist the source in recalling repressed memories. The “futility” interrogation approach has proven to be successful in many cases of this type. However, it should be considered that in some cases, it may be desirable to avoid topics which the source has held back, depending on the type of information the interrogator is seeking.

#### ■ **Measures to Insure Accuracy.**

● **General.** While the interrogator attempts to get the maximum amount of usable information as circumstances permit, he must also strive to increase the value of this information by insuring its accuracy. In this respect, the interrogator must distinguish among things the source has seen, heard, or assumed. In each case, the information should be verified. In a like manner, the interrogator should distinguish between information of which the source has definite knowledge, and information of which he is not certain.

● **Use of numbers.** Great care should be exercised in the use of numbers. The average person does not think in terms of large numbers. However, when asked, “What is the strength of your company?” an EPW will often provide a quick

answer without concern for accuracy. Especially in the case of overcooperative sources, there is a danger in accepting their estimates at face value. A better approach is to begin with a question as to the number of men in his squad; how it compares in strength with other squads; the number of men in his platoon; and finally, asking him about the strength of his company. This will provide both the interrogator and the EPW with a firmer basis for the answer to the ultimate question, the strength of the company. It may also be foolish to ask an EPW to provide an answer to a question such as this: "What percentage of your company are specialists?" Although he may give an answer, he may not have any idea what "percentage" means, what the number of specialists is, or what the term "specialist" really means. Statements that losses were "high" or "low," and other similar responses, provide little information. Specific numbers should be obtained where possible; such words as "high" and "low" mean different things to different people.

### Termination Phase

■ The termination phase of an interrogation will depend on various factors. Examples of these factors are shown below.

- If the source is wounded, sick, or elderly, the interrogator may be forced to terminate the interrogation or discontinue it until a later time.
- The amount of information possessed by a source may be so great that several sessions will be necessary to obtain all the desired information.
- The attitude of the source may indicate termination or postponement. He may become bored or refuse to cooperate.
- All questions may be answered and the requirements satisfied.
- The interrogator may lose the initiative and decide to postpone the interrogation.

■ Whatever the reason for terminating the interrogation, the interrogator should consider the possibility that he or someone else may want to question the source at a later date. For that reason, the interrogation must be terminated on a friendly basis. The source is informed that the information gained will be checked for accuracy; and if the source wishes to correct any statements or furnish further information, he should contact the interrogator. Therefore, the interrogator should state that the source may be "talked to" again at a later time. Finally, to facilitate future interrogation, the interrogator reinforces the approach technique used to gain the source's cooperation. The interrogator must never imply or state that the source is of no further value and will not be reinterrogated.

■ The time required in bringing the interrogation to a close may sometimes be used successfully to secure valuable additional information. A reluctant source may tend to drop his guard after the questioning has ceased and the interrogator has put his notebook away. The source who has successfully suppressed pertinent facts during the interrogation may mention such facts during the period immediately following the interrogation. By carefully handling the source, the interrogator may secure the very facts that eluded him during the interrogation.

### Recording and Reporting Phase

■ **Recording.** To insure accuracy and retention of details, it usually is essential that some form of notes or record be made during the course of, or immediately after, the interrogation. Whether or not the notes are taken during the interrogation will depend upon the circumstances, the cooperativeness of the source, and the nature of the topic under inquiry. In general, notes should be taken only if it can be done

without distracting or silencing the source. In some cases, it may be desirable to have an assistant take notes or employ sound recording equipment. The interrogator usually should refrain from note-taking until he has made a favorable start and the source is communicating freely. At no time should note-taking by the interrogator be in such detail that it interferes with the interrogator's observation of the source's reactions to questions. Notes may be read back or sound recordings replayed for the source as a means of calling to his attention an inconsistency or to refresh his memory when pursuing a point which may have been covered earlier. Sound recordings made on one source may also be useful in interrogation of a second source who is uncooperative. Notes taken during the interrogation should be reviewed as soon as the source departs, and gaps in the recorded information should be filled in while the details are still clear in the interrogator's mind. When sound recording equipment is to be used, it should be tested under simulated interrogation conditions. Immediately after the interrogation, the recording should be checked for clarity. The sound recording must be properly identified and secured at the conclusion of the interrogation.

■ **Reporting Phase.** Reports of interrogations may be either oral or written, formal or informal, and the exact type of report rendered will be as directed by standing operating procedure (SOP) or by the agency or individual directing the interrogation. Oral reports usually are rendered when the value of the information to be reported is contingent upon the speed with which it reaches the using agency; they should be followed by a written report to confirm and to provide a record for future reference. Many report forms will require the interrogator to include a narrative appraisal or coded evaluation of the source's reliability. Evaluation of the information normally is not required, but the interrogator does perform an appraisal service by accurately reporting the information obtained, and by his own observations of the source, if they are pertinent or significant. Conclusions based on the reported facts should be included so far as is practicable, but must be clearly identified as such. The most important information which the interrogator obtains may be valueless unless it is reported to intelligence agencies in usable form. This means that the interrogation report must be accurate, complete, and concise.

## The Polygraph

### General

One of the technical aids available to the interrogator is the polygraph. While it is sometimes possible to detect that a person is lying by simple observation of such signs as blood rushing to the face, thumping of the heart, an uncontrollable impulse to swallow, or the inability to "look the interrogator in the eye," not all persons exhibit these reactions outwardly. Some individuals are able to maintain a controlled, calm attitude with no outward sign of emotion. Through the use of a polygraph, certain physiological changes in blood pressure, respiration, and changes in skin resistance can be recorded mechanically. When properly diagnosed by a trained, competent examiner, these findings usually give some indication as to whether or not a person is telling the truth. The fear of detection appears to be the principal factor causing the physiological changes to take place in an individual, but other factors such as remorsefulness or consciousness of wrongdoing can act as contributing factors. Since this instrument requires a trained examiner and controlled physical facilities, its use will be limited, especially in tactical interrogations. In this regard, some of the factors discussed in the following paragraphs will not be applicable to the normal EPW type interrogation. However, interrogators should be aware of the capabilities of the polygraph and its availability for use in special cases. The situation may well arise wherein it is essential that the truthfulness of a



particular source be determined. The polygraph has been proven to be a valuable aid in making this determination.

## Use of the Polygraph

■ **Polygraph Examination Authorization.** The use of a polygraph examination is governed by AR 195-6. When a polygraph capability is present or available, interrogation personnel, particularly chiefs of interrogation elements, must be familiar with this regulation. No polygraph examination will be conducted without the authorization of the Assistant Chief of Staff for Intelligence (ACSI); Commander in Chief, US Army Europe/Seventh Army (USAREUR); Commander, UNC/USFK/EUSA (Eighth United States Army); CG, US Army Intelligence and Security Command (INSCOM) or their authorized representative.

### ■ Capabilities.

● **Establishing knowledgeability.** The polygraph can be used to examine selected potential interrogation sources to establish the extent of their knowledge. It permits the interrogator to concentrate his efforts on the most potentially productive source, particularly in counterintelligence and criminal interrogation.

● **Establishing veracity.** Indications of deception recorded by the polygraph will provide valuable means for providing the interrogator with specific points upon which to concentrate his interrogational efforts. Just as valuable is the evidence of a lack of attempt to deceive on the part of a person furnishing information; this indicates to the interrogator that the source may be truthful concerning any information he may reveal.

### ■ Limitations.

● **Emotional tension or extreme nervousness.** When the source has just been extensively interrogated or is at the point of exhaustion at the time of testing, polygraph findings often are inconclusive. It is normal, however, for most sources to be somewhat apprehensive and nervous during a test with the polygraph. The polygraph examiner must distinguish between natural emotional tension or nervousness on the source's part and attempts at deception.

● **Physiological abnormalities.** Heart and respiratory disease, excessively high or low blood pressure, the use of drugs, narcotics, or barbiturates, and recent serious illness or injury could adversely affect the examination. The interrogator should be alert to detect any such abnormalities in a source and inform the examiner of them prior to the examination.

● **Mental abnormalities.** Sources who are feeble-minded and those suffering from mental or emotional disorders pose a definite limitation to examination. Such sources may not understand the question posed, nor be able to distinguish between truth and falsehood. In addition, the use of the polygraph on persons of little education or sophistication (often encountered in internal defense and development operations) may induce an irrational fear or psychological reaction that completely negates the value of the examination.

● **Unresponsive sources.** Some sources will fail to respond sufficiently to produce conclusive results. This group would include, among others, sources who have no fear of detection, who are able to control their responses through mental attitude, or who are physically exhausted or under shock.

● **Answers.** No narrative answers can be obtained—only "Yes" or "No" an-

swers. Subsequent interrogation, however, may elicit the necessary details, using examination results as a basis for questioning.

❶ **Questions.** Only a limited number of relevant questions can be asked in any given test. Consequently, test questions must be carefully planned and selected.

❷ **Consent of source.** An obvious limitation is the necessity for obtaining the consent and willingness of the source to undergo a polygraph examination. US citizens have certain rights which must be safeguarded. AR 195-6 governs the use of the polygraph in this connection. These rights normally are not applicable to non-US sources; however, the source's cooperation, or lack of it, has a direct influence on results of any examination. Status of Forces treaties may provide restrictions on polygraph examinations for some non-US sources.

❸ **Variance in ethical values.** When a source holds ethical values which render him insensitive to specific matters on which he is being questioned, the results of the examination may be inconclusive. The examiner must attempt to ascertain the cultural background of the source and to understand those aspects that have a direct bearing on the validity of the examination.

■ **Physical Facilities.** The examination should be conducted in a plain room, free from distraction (fig. 2-2). A two-way mirror may be necessary to provide a means for witnesses to observe from an adjoining room without distracting the source. Such precautions preclude any later charges of mistreatment or mishandling of the source on the part of the examiner. The room should also be equipped with listening and recording devices. In addition, para 1-5j, AR 195-6, requires the presence of a female witness when testing a female source.

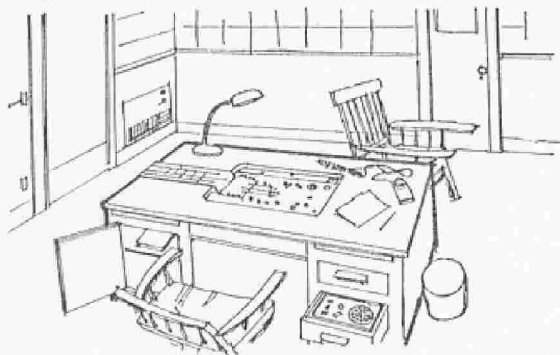

■ **Responsibilities of the Examiner.** Aside from the preparation of the physical facilities and the polygraph, the examiner must determine if the source is psychologically and physiologically ready for the examination. In addition, the examiner is responsible for the final formulation and phrasing of the questions to be asked during the examination. These questions are based upon information concerning the case and the source as obtained from the investigator prior to the examination.

■ **Employment.** For the examiner to conduct an effective polygraph test, he must be provided with all the available facts and circumstances forming the basis for the test. Such information is essential to the examiner so that, in coordination with the interrogator, he will be able to formulate the questions to be asked during the examination. Polygraph tests should not be conducted unless the examiner agrees that sufficient facts are available upon which pertinent questions can be based and constructed. It is the responsibility of the interrogator to coordinate with the

examiner prior to the examination. The interrogator must brief the examiner on the complete situation concerning the source, and the interrogator must provide all available information pertaining to the source's background—his past life history and all employment data. Information of this sort not only enables the examiner to engage the source in conversation more readily, but more importantly it gives him data for preparing control questions for the test (i.e., those involving probable lies).

■ **Summary.** The interrogator should remember that the polygraph is an investigative aid only. It should never be used as a substitute for exhaustive interrogation or investigation. It may be used to guide the interrogator into the correct channels of interrogation, to select the proper person to interrogate, or to aid in determining the truth of a person's statements. The instrument cannot perform miracles—the polygraph only records the physical responses of the human body to psychological stimuli. Disposition of a source should never be based solely on the result of a polygraph examination. A positive result on such an examination does not discount any information upon which the interrogator based his initial doubts which led him to request the examination. The interrogator can expect one of only four conclusions from the polygraph examination:

- There were indications of attempted deception.
- There were no indications of attempted deception.
- The examination was inconclusive.
- No opinion could be rendered due to incomplete examination; e.g., suspect refused to continue.

### Repeater Rubber-Band Gun Gets "Big Game"

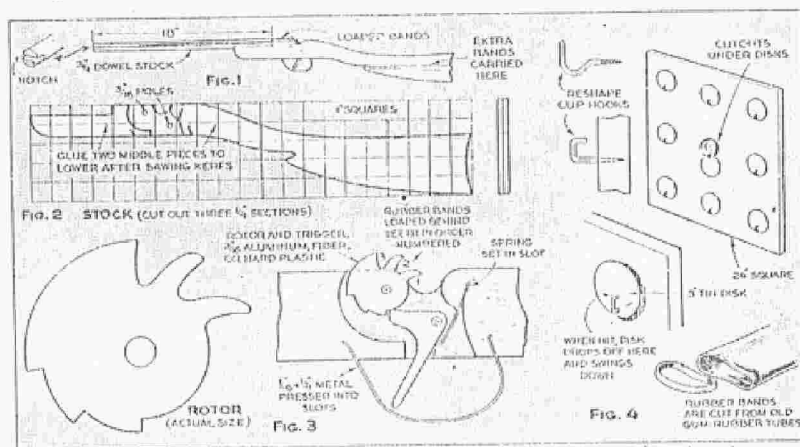

Here's a rubber-band gun that looks like a gun, cocks with a click, and shoots three bands one after another on one loading. By making several of these guns and a target panel, on which pictures of big-game animals are revealed when the flying bands knock aside covering disks, you will have an interesting indoor game.

Lay out the pattern of the stock on three sheets of 3" plywood bradded together. Then drill the two 3/16" holes and saw the stock to shape. Now separate the three sections of the stock. Cut away part of the

middle one to accommodate the trigger and rotor. Also make saw kerls to take the trigger spring and guard.

Glue the two pieces of the middle section in their original position on one of the solid sections. After installing the rotor, trigger, and spring, put the other section on temporarily to see that everything works. If it does, glue this section in position. Notch the back 4" of the barrel to fit the stock and attach with two 1/8" countersunk wood screws after gluing. When you use the gun, squeeze the trigger slowly.—R. R. COLE.

## OBTAINING AND RECORDING INFORMATION AND EVIDENCE

This is an Army course in detective work. (FM 19-20). I've left out the purely technical sections which deal mainly with collecting evidence to be submitted to a crime lab or the prosecution. What's left will be of interest to the U.S. Militiaman for his own investigations. It will also help the reader to develop his own powers of observation.

### Notes, Photographs, and Sketches

Notes, photographs, and sketches are made of the crime scene and of the actions taken during the crime scene search and throughout the investigation. They are an essential part of the investigative process. They help you accurately recall events and identify evidence in court. They serve as valuable references of details uncovered during the search. And they form a detailed record attesting to the thoroughness of the process.

CONTENTS	
	Page
NOTES .....	23
PHOTOGRAPHS .....	24
Photographing Scenes and Objects for Evidence .....	26
Photographing Humans for Evidence .....	27
SKETCHES .....	28
Making a Rough Sketch .....	28
Locating Evidence on Sketches .....	32

### NOTES

Notes are your most personal and readily available record of the crime scene and of your investigative process. No rule exists concerning the detail the notes should reflect. Your objective should always be to make notes that will be fully meaningful months after the event. Remember that a note that is clear to you a short time after it is written may be unintelligible later. Do not expect to rely on your memory of associated events to give single word notes their full meaning.

Note making should begin with your assignment to the case and continue through the completion of the investigation. Supplement your notes with photographs, sketches, and scale drawings. Record your notes in the order that you receive information, take actions, and make observations. The sequence of your notes should be *logical* and *systematic*.

Your notes aid in the accurate recall of events for testimony in court and they furnish raw material for your written report on the case. Your formal written report may not need the level of detail or items of

information that are needed for your testimony. The details you record in your notes should anticipate both the needs of the written report and the questions you may be called on to answer for attorneys or members of a court.

The type of notebook you use, which may seem to be a minor point, can be important. Unless a separate notebook is to be used for each case, a looseleaf notebook is better than a bound notebook. Your notebook may be examined in court. If notes from several cases are included in the same book, there is a chance of unauthorized disclosure of information on matters not being dealt with in the case being heard. If a looseleaf notebook is used, the pages on other cases can be removed. Unauthorized disclosure of facts related to other cases is thereby avoided.

In major cases with a lot of physical material and a large crime scene, you may want to use a portable tape recorder. By taping your observations and findings, you can include more details in your notes. In all cases, the tapes should be transcribed into a written record that you may carry into court.

Keep your notes in a safe place with the local office case file. Even after a criminal has been convicted and sent to prison there is always a chance that an appeal or other civil action will require your appearance in court again.

Print your notes if your handwriting is not easy to read. Use blue or black ink that will not smudge easily. Number each page of notes and identify it with your name, your title or rank, the case number (when known), and the current date. Also record the times when an action is taken, when information is received, and when an event is observed. *Do not edit or erase your notes.* If you make a mistake, line out the entry, initial it, and then write the correct information.

Your notes should include a detailed description of the scene and any item you think pertinent to the case. Your description should be as complete as you can make it. See Chapter 4 for discussion of how to develop descriptions.

Record the exact location, giving measurements and triangulation of evidence, where the item was found. See Locating

Evidence on Sketches later in this chapter. Cite the relative distances separating various items. State the techniques used to collect the evidence and to record identifying marks placed on the item or the package in which the evidence was placed. Be sure to tell what techniques were used to provide crime scene security and to search the scene. And include any actions you take that may have a bearing on the evidence you obtain or significantly affect the investigation.

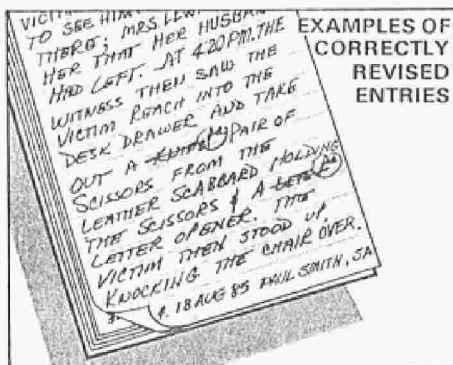

## PHOTOGRAPHS

A picture may or may not be worth a thousand words. But it is certain that photography is a valuable aid in criminal investigations. Useful photographs can be made without great expertise.

Crime scene and evidence photographs are simply the photographs made to supplement notes and sketches or to clarify a point relative to a case. They are also made to identify personnel and to form a permanent record of fragile or perishable evidence. Time is an essential factor. *Objects must not be moved or examined with thoroughness until they have been photographed* from all necessary angles. There are situations in which the object of interest undergoes significant change with the passage of time. Thus, photographic equipment must be kept in a constant state of readiness.

Photographs are admissible in court if you can testify that they accurately depict the area observed. The accuracy of a photograph

relates to the degree it represents the appearance of the subject matter as to form; tone; color, if applicable; and scale. A lens that will accurately record objects and areas in focus may not correctly portray distances between objects nor show objects out of focal range in their proper perspective. In such situations your crime scene sketch and your notes will play strong supporting roles.

Providing a photograph's negative is usually enough proof to refute an allegation that a photograph has been altered. However, if enlarged photographs are made for presentation in court, a contact print without borders should also be made. Because scale, distances, and perspective are important in interpreting photographs taken at crime scenes, include a ruler or other scale measure in such a photograph when you can. As some courts may not allow even this minor modification to the scene, you also should take an identical photograph without the scale indicator.

A photograph, to be high-quality evidence, must depict the scene, persons, and objects precisely as they were found. Photography is an exclusive action in the crime scene search. No people may be working within the scene at the time it is photographed. And extraneous objects, like police and investigative equipment, are excluded from the photos.

Record the technical data for each photograph in your notes. Each photograph must be precisely identified. This data becomes part of the permanent record of the case. A good way to do this is to create a photo log. Assign each photo a number. Tell what each photo depicts. Cite the time the photo was taken, the type of photo, and the distance to the focal point. Tell what camera was used and at what height it was held. Give the position of the camera or angle of the camera shot. Say what lens was used, if flash was used or film reloaded, and describe any photo overlays. In addition to recording identifying data in your notes, you must do so on a photography sketch.

All camera positions and distances to the focus point must be recorded on the crime scene photograph, sketch. You can do this by measuring from a point on the ground directly below the camera lens to an immovable object used as the focus point for the picture. In making crime scene

photographs, it is best to keep the camera at about eye level. *If an explosive was used at a crime scene and there is residue of the explosive present, do not use a flash attachment.* Use a tripod or raise or lower the camera height to get the object to be photographed in proper focus. Take overlapping photographs of interior scenes intended to depict an area as a whole, moving in one direction around the room or area.

#### CAMERA POSITIONS FOR OVERLAPPING PHOTOGRAPHS

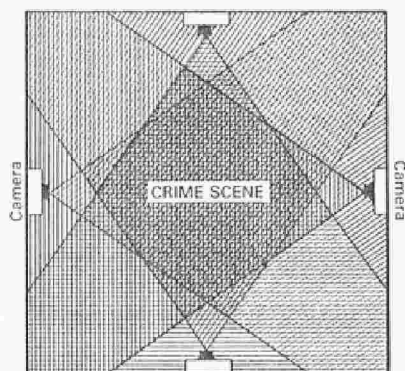

This overhead view shows how photos will overlap.

#### SAMPLE PHOTO LOG

SA TIM C. WINKLER

Report Number 063-85-4807

Date 23 NOVEMBER 1982

TIME 0804 Began taking crime scene photographs and drawing rough sketch to depict camera positions and distances. All photographs taken at eye level height (5' 6") unless otherwise indicated. All interior and exterior photographs are taken with the following equipment:

TYPE CAMERA CANON AE-1 BODY NUMBER 603113

LENS FOCAL LENGTH AND LENS SERIAL NUMBER 50mm 114 10492

TYPE OF FILM ESTACHROME NUMBER OF EXPOSURES 36

ASA 400 FILTRATION CANON HAZE

F/STOP SEE REMARKS SHUTTER SPEED SEE REMARKS

FLASH ATTACHMENT NA FLASH SERIAL NUMBER NA

EXPLANATION OF TERMS USED IN REMARKS COLUMN: Camera held in horizontal format, unless otherwise noted. DA-Photograph taken from directly above the object; V-Camera held in vertical format; N-Normal lens; M-Macro lens; WA-Wide angle lens.

TIME	PHOTO	TYPE PHOTO	DEPICTING	DISTANCE	REMARKS
0910	# 1	OUTSIDE ESTABLISHMENT	DISTANCE TO BUILDING # 3262-A FROM WALKWAY	14' 7"	N, 1/500 SEC, F/11
0913	# 2	OUTSIDE ENTRANCE	OPEN DOOR TO APARTMENT 126-A	6' 9"	V, N, 1/500 SEC, F/8
0918	# 3	EVIDENCE	PISTOL ON THE FLOOR IN THE DOORWAY	2' 6"	DA, N, 1/250 SEC, F/5.6

The most important element in investigative photography is maintaining perspective. Photographs must reproduce, with the same impression of relative position and size of visible objects, the scene as it would appear to someone standing in the photographer's shoes. Any significant distortion in the perspective will reduce, or destroy altogether, the photo's evidence value. The best way to maintain natural perspective is to aim the camera so a 90-degree angle is formed by opposing walls. If outdoors, use fixed objects like trees to maintain perspective.

The chain of custody of investigative photographs is maintained in the case file. When you send film by mail to a commercial processor, use registered mail with a return receipt. Keep registered mail receipts and copies of work orders for film processing in the case file.

#### PHOTOGRAPHING SCENES AND OBJECTS FOR EVIDENCE

The most important rule in crime scene photography is to photograph all evidence or possible evidence before anything is moved or touched. This rule applies to general scenario shots and to closeups of specific items of evidence.

**Fingerprints** that can be seen without the aid of dusting powder should be photographed up close before dusting. There is always the danger of the print being damaged during the dusting process.

Photographs should be taken of **impressions** of which a cast will be made. Hold the camera directly above the ground and the flash close to the impression at an angle. Use flash at all times. Oblique light will reveal more details. Take the closeup with a ruler near the print, so the proper scale can be determined. Make at least four photographs of each impression. Take a picture from every side, using light from each different direction. This reduces the chance of details being missed in a photograph because of shadows cast by a light sources from only one direction. Make sure the date, case number if known, your name, exhibit number if known, type of film used, and camera setting shows in the photo. It should be

written on paper and placed next to the impression.

Photographs of **tool marks** must show the marks and enough of the surface on which the marks are located to identify them positively. Show the mark as it actually appears and in its overall relationship to other objects at the scene. Include an ordinary ruler, along with data identifying the location, situation, and case, in each picture to provide the lab examiner a scale of measurement.

When photographing **burglary, house-breaking, and larceny scenes**, you will want to pay particular attention to the interior and exterior of the building and to damaged areas. Note particularly any damage around the points of entry and exit used by the criminal. Take closeups of damaged containers like safes, wall lockers, or jewel boxes that were the target of the offense. Take both closeup and perspective photos of tool marks. The latter will allow you to note the position of marks with respect to the general scene. And fingerprints and footprints, of particular value in these cases, should be photographed before they are lifted or preserved.

When photographing an **arson scene**, complete coverage of the damage is important. Perhaps of even greater importance are photos of objects or areas suspected to have been the point where the fire began. Make closeup photographs of all such objects or areas.

If the fire is in progress, seek out various angles from which to take photographs. But try to keep out of smoke-filled areas. Your first photographs should be of the entire structure. Use color film to show the color of the smoke, flames, and vapors. Take a series of photographs at intervals of several minutes to show the intensity and direction of the fire. Then photograph any spectators. The perpetrator may be present, watching the results of his or her efforts.

When the fire is extinguished, photograph the entire exterior of the structure. Then photograph all affected interior areas and any evidence found. Photograph in detail suspected points of the fire's origin and areas



showing an "alligator" burn pattern. You cannot rely on your exposure meter when trying to photograph charred wood. Instead, use a two- or three-stop overexposure.

**Accident scenes** should be photographed as soon as possible after the event. Except when photographing vehicles, set your lenses at normal focal length. This will prevent distortion in the relative width of roads, distances between points, and the like. If special lenses are used, note that fact in your record of the search and give a description of the lenses used.

Photograph the overall scene of the accident from both approaches to the point of impact. Capture the exact positions of vehicles, injured and deceased persons, and objects directly connected to the accident. If possible, take photographs of skid marks before the vehicle is moved. Then take photos of the marks after the vehicle is moved. Photograph all points of impact, all marks of impact, and all damage to real property. Be sure you record any pavement obstructions and defects in the roadways. Make closeup photographs of damage to each vehicle. Make at least two for each vehicle. The first should show the front and one side. The second closeup should show the rear and other side of the same vehicle. And, of course, you will want photos of tire tracks, glass, and other associated debris.

Usually, **death scene** photography must be more extensive than that of other crime scenes. This is due to the severity of the offense. Photograph the approaches to the scene and the surrounding areas (the yard of a building in which a death occurs, general area surrounding an outdoor crime scene). Take closeup photographs of the entrance and exit to the scene or of the route most likely to have been used if the entrance and exit are not obvious.

Make general scenario shots showing the location of the body and its position in relation to the room or area in which it was found. And give 360-degree coverage of the room or scene with overlap points clearly identified in the photographs. All evidence must be photographed—shots establishing the evidence in relation to the scene, shots of evidence closeup, and shots of evidence

closeup with a ruler to show perspective and size. After the body is moved and each item of evidence is removed, photograph the area underneath them if there is any mark, stain, additional evidence, or other apparent change. Photograph any "plastic" and contaminated prints before you try to collect them. And photograph developed latent prints prior to lifting. Include shots of areas where prints are discovered if the areas were not included in other photographs. Photograph bloodstains, including their locations, with color film if you can. Black and white pictures should also be taken.

### PHOTOGRAPHING HUMANS FOR EVIDENCE

Photographs should be taken of victims or suspects of crimes like assault, aggravated assault, or sex offenses that involve bodily harm. Photographs should be taken of any wound, injuries, stains, or other trace evidence that may be on the person or the person's clothing. *Written permission* should be obtained from living persons before photographing them. If photographs of a body area that is normally clothed are required, a witness should be present. If the victim or the suspect is a minor, the *written consent* of the parent or guardian is needed. The photography must be done with the consenting person present.

Photographs of parts of the body that usually are not visible when a person is clothed are taken *only* under the direct supervision of the examining physician. It is the physician's testimony that the photographs are intended to illustrate. Thus, it is unusual if this type of photograph is taken at the crime scene.

The evidence value of a photograph of a deceased person is reduced if you include views that could later be alleged to be deliberately inflammatory. The unneeded exposure of sexual organs is a case in point.

Take at least two full-length photographs of the body at 90-degree angles to each other. Hold the camera as high as possible, pointing downward toward the body. Include at least one closeup photograph of the head and shoulders of the victim. Position the camera for this shot directly above the head and

shoulders of the body. Take as many closeups of the body as needed to show wounds and injuries. When photographing a body that is lying in a horizontal position, hold the camera directly over the victim's head and shoulders. Do this at a height of no less than 5 feet. Closeup photographs of injured parts of the body are most effective in color. But black and white pictures should also be taken.

The presence of wounds, blood, or other discolorations on the corpse may affect

identification. Using a lens filter to create more lifelike tones may aid identification.

Photographs of the body should also be taken during the autopsy. Cooperate with the pathologist to obtain these. Your photos should include full-length views before and after undressing and/or washing. Photograph identifying marks and closeups of all wounds with and without a measuring device. Both color and black and white photos should be taken.

## SKETCHES

Properly prepared sketches may be used to question people, to prepare a report of investigation, and to present information in court. Sketches also are valuable sources of information for trial and defense counsels. Sketches are often introduced in court as evidence. They are used to acquaint the court with crime scenes and to help witnesses orient themselves as they testify.

Sketches complement notes and photographs made during a crime scene search. A sketch communicates information the way a photo does, but has the advantage of being able to have unneeded and distracting detail left out. Sketches concentrate attention on the most essential elements of the crime scene and their relationships. There are two kinds of crime-scene sketches: rough and smooth. A rough sketch is the kind you draw while at the crime scene. The purpose of a rough sketch is to portray information accurately, not necessarily artistically. You do not need to be artistic to draw a good rough sketch. A rough sketch is usually not drawn to scale. But it must show accurate distances, dimensions, and relative proportions. In order to eliminate excessive detail in a sketch, you may have to draw more than one. For example, one sketch may be devoted to the position of the victim's body and one or two of the more critical evidence items. Other sketches might show the lay of evidence items with respect to the point of entry or to other critical points. *Do not make changes in your sketches after you leave the scene.*

A smooth sketch is a more finished version of a rough sketch, using the information

provided in the rough sketch. A smooth sketch need not be drawn by the same person who draws the rough sketch. But whoever draws the rough sketch must verify the accuracy of the smooth sketch. In fact, it is best if a smooth sketch is made by an experienced draftsman. (The engineer officer may be able to provide a qualified person for this task.) The name of the person who drew the smooth sketch is shown in the report and on the sketch. A copy of the smooth sketch is attached to each copy of the investigation report. Smooth sketches are often drawn to scale from information in the rough sketch. By making a scaled drawing, the numbers showing distances can be left out. If the smooth sketch is not drawn to scale, these distances must be shown.

### MAKING A ROUGH SKETCH

Any kind of paper may be used for a rough sketch. However, bond or graph paper is best. It can be placed on a clipboard large enough to form a smooth area for drawing. To prepare a rough sketch you need:

- A soft lead pencil.
- A 100-foot steel tape.
- A straightedge ruler.
- Several thumbtacks to hold one end of the steel tape down when you are working alone.
- A magnetic compass.

You may add as many items to this list of basics as you like.

Several items of information are considered essential in a crime scene sketch. But do not restrict your sketch to these items alone. The major constraint on detail in

sketching is that the result must be completely intelligible to a viewer without a detailed study. If you include too much detail, the major advantage of a sketch over a photograph is lost.

Each sketch should include the critical features of the crime scene and the major, discernible items of physical evidence. Evidence sketches must show *accurate* measurements of the crime scene. They also show the location of evidence established by

use of the triangulation method. A photo sketch must show camera positions and distances to focus points.

Each sketch should have a caption to identify the illustration. For instance, a caption might read: "Rough sketch showing camera positions and distances." Each sketch must have a legend. The legend explains the symbols, numbers, and letters used to identify objects on the sketch. Use standard military symbols where practical.

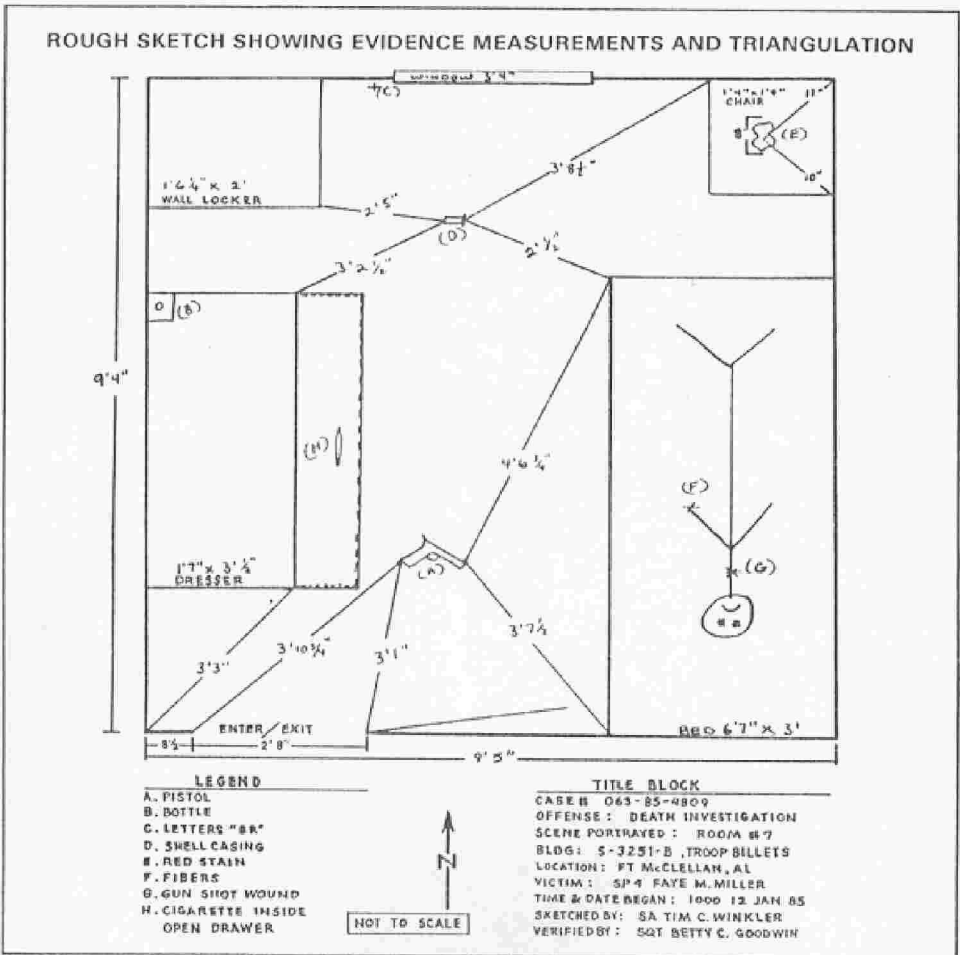

Your sketch must also show the compass direction north. You will need to include a scale designation for scaled drawings only. If no scale is used, write "not drawn to scale." And each sketch must have a sketch title block containing the following entries:

- Incident report number: MP Report, USACIDC sequence number, or Report of Investigation (ROI) number.
- Alleged offense.
- Name and rank or title of the victim.
- Scene portrayed—citing room number, building number, and type of building, (PX, commissary, house, troop billets).
- Location—citing complete name of installation, city, state, and zip code.
- Time and date sketch was started.
- Name and rank or title of person who drew the sketch.
- Name and rank or title of person who verified the sketch.

### FINISHED SKETCH DRAWN TO SCALE

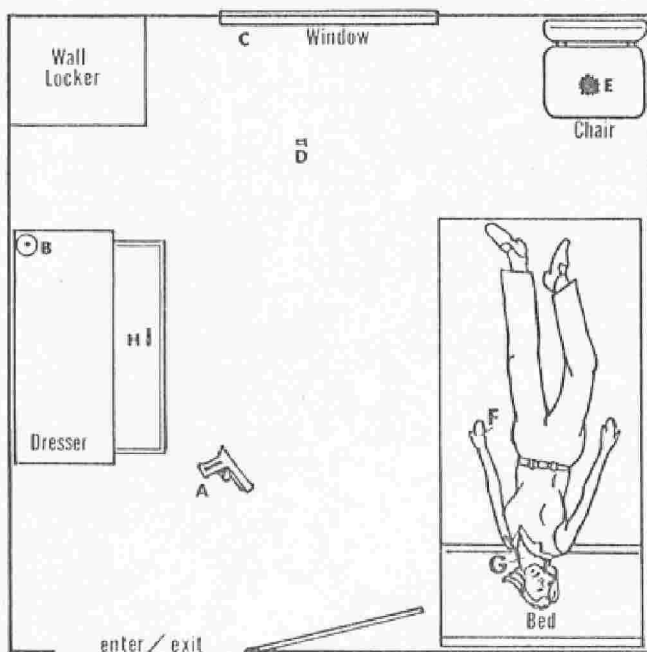

#### LEGEND

- A. Pistol
- B. Bottle
- C. Letters "BC"
- D. Shell casing
- E. Red stain
- F. Fibers
- G. Gun shot wound
- H. Cigarette inside opened drawer

SCALE: 1/5"=1 FOOT



#### TITLE BLOCK

Case # 063-85-6809  
 Offense: Death Investigation  
 Scene portrayed: Room #7  
 Bldg S-3254-B, Troop Billets  
 Location: Ft McClellan, AL  
 Victim: SP4 Faye M. Miller  
 Time & Date Began: 1000 12 Jan 85  
 Sketched by: SA Tim G. Winkler  
 Verified by: SGT Betty C. Goodwin

Measurements shown on the sketch must be as accurate as possible. Steel tapes are the best means of taking accurate measurements. A measurement error on a sketch can introduce doubt as to the competence of an entire crime scene search.

Measurements should be made and recorded uniformly. If one aspect of a sketch is accurate, such as the dimensions of a field in which a body was found, and the position of an object within the field is only roughly estimated, the distortion thus introduced

renders the sketch relatively useless. It is important that the coordinate distances of an item in the sketch be measured in the same manner. For example, one coordinate leg of the victim should not be paced and the other measured with a tape measure. It is also a mistake to pace off a distance and then show it on the sketch in terms of feet and inches. This implies a far greater degree of accuracy than the measurement technique could possibly produce. If the point arose in court, such imprecision could greatly detract from the value of the sketch.

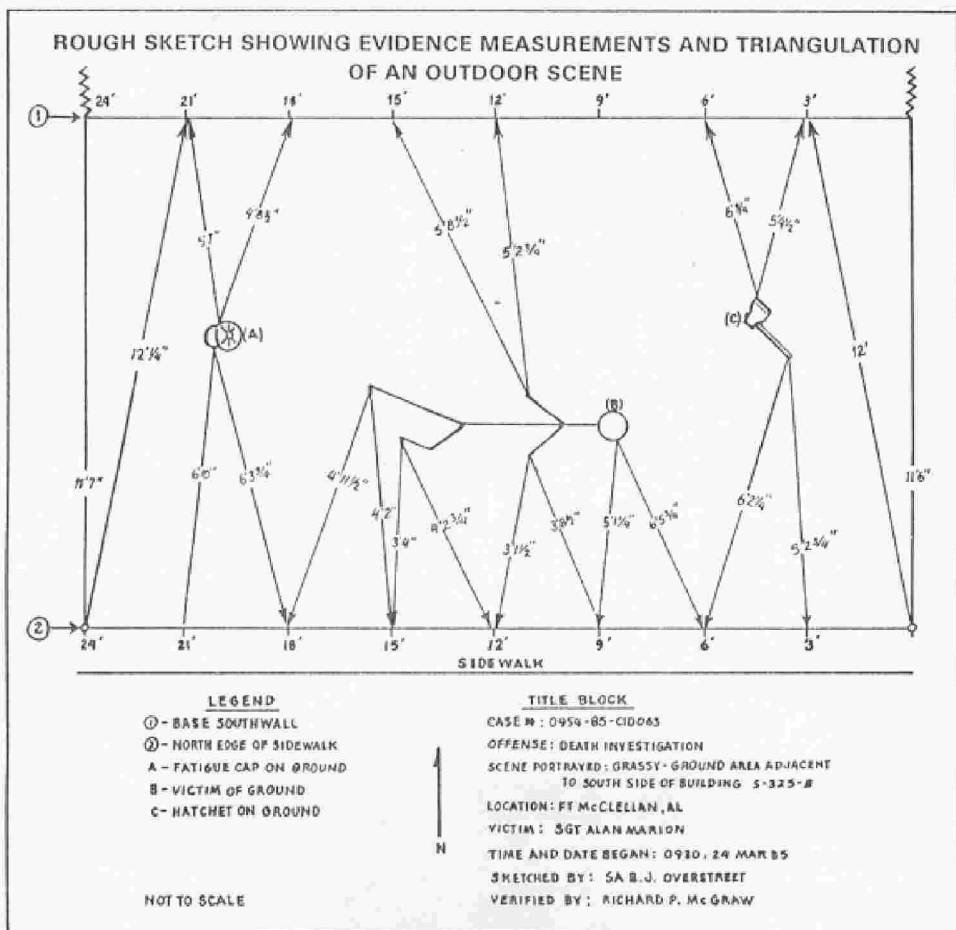

### LOCATING EVIDENCE ON SKETCHES

Various sketch methods may be used to locate evidence and other important items at the scene. The simplest form of a sketch is a two-dimensional presentation of a scene as viewed directly from above. Evidence is located on this type of sketch by triangulation. Triangulation is used for indoor and outdoor sketches having fixed reference points. Objects are located by creating a triangle of measurements from a single, specific, identifiable point on an object to two fixed points, all on the same plane, at the scene. If movable items are to be used as reference points, they must first be "fixed" themselves. Do not triangulate evidence to evidence. Do not triangulate under or through evidence. Do not take a line of measurement through space. Measure your line along a solid surface like a floor, wall, or table top. In the interest of clarity, keep the angle of triangulation measurements between 45 and 90 degrees on the sketches.

Regular shape items are fixed by creating two separate triangles of measurements. Each originates at opposite points on the object and ends at two fixed points, on the same plane, at the scene. This is commonly known as the 2-V method of triangulation.

Pliable objects are fixed by creating a single triangle of measurements from the center of mass of the object to two fixed points, on the same plane, at the scene. You also measure the longest and widest dimensions of the object.

Inhabited outdoor areas usually have easily defined, fixed reference points such as buildings, edges of roads, and sidewalks. When these are present, the triangulation method can be used to establish the location of objects. But uninhabited or remote areas may not have easily defined, fixed points within close range. In such cases, objects will have to be located by using the intersection-resection method taught in map reading. See FM 21-26 for a more complete discussion of intersection-resection method.

Cross-projection is used to add another dimension to sketches. The added dimension is useful when items or locations of interest are on or in wall surfaces in an enclosed space. The walls, windows, and doors in a cross-projection sketch are drawn as though the walls had been folded out flat on the floor. The required measurements and triangulation of evidence are then entered on the sketch. A cross-projection drawing may be used as a scaled drawing.

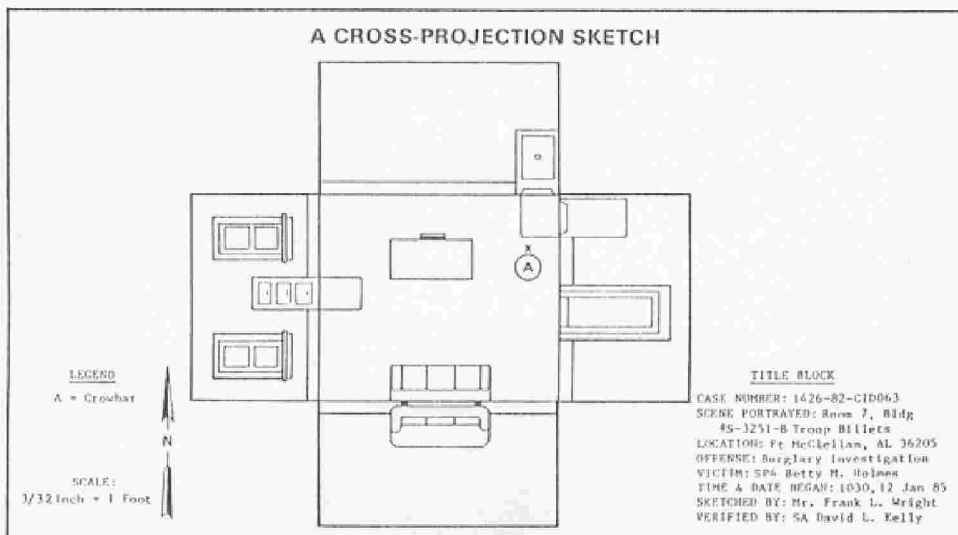

## Observations, Descriptions, and Identifications

Careful observations and detailed descriptions are investigative tools.

Observations help you build descriptions of persons, objects, places, and events so that who or what was seen may later be identified. Observations also help you find or identify persons, objects, and places from descriptions built by others.

Descriptions help you relate to others what you have seen. Descriptions may be either written or oral. They include signs, gestures, sketches, and other means to convey information about what was seen by an observer.

Most people are not trained or experienced in remembering and evaluating what they see. Thus the observations and descriptions of witnesses may not be as detailed nor as objective as those made by trained observers like investigators. Trained observers know that their observations can be affected by lack of sleep, or by illness, or by other outside influences. And they make allowances for outside influences when they interpret what they see.

Environmental factors like weather and light can influence what people see. The presence of unrelated, distracting circumstances can influence what people see by focusing their attention in a particular direction. For example, a spectator watching an exciting play on a football field may fail to note the actions of a person sitting next to him. And the passing of time between when an event is seen and when it is recalled can cause the observer to forget or confuse details of the event, thus influencing his description of what he saw. Where an observer is at the time he sees an event influences what he sees. It is unlikely that more than one or two people will view an event from exactly the same place. Thus, a difference in location may account for a difference in observation. Someone observing an event from a great distance may be able to give a good overall description of what took place. But he might

CONTENTS	
	Page
<b>OBSERVATIONS AND DESCRIPTIONS</b>	
<b>BY INVESTIGATORS</b> .....	34
Persons .....	34
Objects .....	38
Events .....	39
Places .....	39
<b>OBSERVATIONS AND DESCRIPTIONS</b>	
<b>BY WITNESSES</b> .....	41
<b>IDENTIFICATION</b> .....	41
Composites .....	41
Lineups .....	42

not be able to see and give the details that someone seeing the same event at close range could give. On the other hand, the closer person may be unsure of the overall picture.

Psychological, physiological, and experiential factors influence what people see and how they retain the information. People tend to evaluate and interpret what they observe by their past experiences with like incidents. They tend to compare the size of an object, for instance, with the size of another object with which they are familiar. A very short or very tall person may fail to judge another's height correctly. Someone 6 feet tall may seem "very tall" to an observer only 4 feet 10 inches tall. The same 6-footer would appear to be "normal height" to a person 5 feet 10 inches tall.

Common sounds, odors, tastes, and other perceptions are usually understood by an observer. But a lifelong urban resident of a big city might not be able to accurately describe a farm scene. Nor could a native of a tropical island be expected to describe a high-speed car accident in minute detail. Stimuli which cannot be easily compared to a past experience are often mistakenly interpreted in terms of familiar things. And, too, a wrong interpretation of a past experience may influence the perception of a present experience.



Interests also affect perception. For instance, many young American boys can quickly recognize and identify the make and model of a car. On the other hand, they may fail to perceive details of the driver, license number, or make and condition of the tires. Special interest training may increase someone's power of observation. But it also may limit the focus of attention, causing the loss of other details. Specialists often have acute perception within their own field but fail to be observant in other fields. An artist may take special note of color, form, and proportion but fail to discern or properly interpret sounds or odors. Conversely, a mechanic may quickly note the sound of a motor or an indication of the state of repair of a car but fail to clearly discern the appearance and actions of the driver.

A person's power to accurately observe and interpret things can be affected by pain, hunger, fatigue, or an unnatural position of his body. Discomfort may cause an observer to fail to correctly interpret things he would normally comprehend. The senses of taste and smell are often distorted by physical ills and external stimuli. These senses are generally the least reliable basis for interpretation. The presence of a strong taste or odor may completely hide the presence of other tastes or odors.

## OBSERVATIONS AND DESCRIPTIONS BY INVESTIGATORS

For investigators a *systematic* approach to observation and description is a must. So is the use of photographs, sketches, notes, and other recording methods. They help you remember what you observe, and they improve the accuracy of your description. Generally, accuracy is most assured if you follow a set pattern. The pattern used most often for observations starts with general features and moves to specific features. For example, when observing to develop a description of a person, you look first at the general features like sex, height, and race. Then you check exact features like color of hair and eyes, unusual scars, or behaviors. Last, you note changeable characteristics like clothing and hair style.

However, when observing persons to try to match them to a description, you may change or reverse your pattern of observation. This is

Emotions like fear, anger, or worry and mental sets like prejudice or irrational thinking patterns may impair perception. For example, a victim of a robbery may have been in great fear of the weapon used by the criminal. He or she may only be able to recall the size of the bore of the weapon and not be able to describe the offender. Such a person might be expected to exaggerate the size of the bore. Or an observer may so dislike another person that he only views the actions of that person and nothing else. Sometimes an observer may have great prejudice against a class or race of people. For example, a person who dislikes police may unwittingly permit this prejudice to affect his view of the actions of a night watchman or a security guard. How he interprets what he sees may be wrong, even if his senses recorded a true report of what occurred.

Good observation requires the skillful use of the five senses to give meaning to what is going on around the observer. The senses of sight and hearing are used most often, but the senses of smell, taste, and touch are also important to observations and descriptions. The ability to observe improves with practice. Events or spoken words that may mean little when seen or heard by an untrained observer may be very meaningful to the trained investigator.

most likely if the person you are looking for has some very noticeable feature. For example, if you are looking for a man with a limp, the first feature you would look for would be the limp. You would then look at general features and go on to note specific features. But even reversed, you are still following a pattern, still using a systematic approach.

### PERSONS

When observing and describing persons, first note a person's general features. General features include sex, skin color, height, build and posture, weight, age, and complexion. Then, observe and describe the person's specific features. Your pattern of observation and description of the specific characteristics of a person normally begins with the head and progresses downward.

NOTABLE GENERAL CHARACTERISTICS OF PERSONS						
SEX	SKIN COLOR	HEIGHT	BUILD and POSTURE	WEIGHT	AGE	COMPLEXION
Male Female	White Black Red Yellow Other Unknown	Exact or Esti- mated in 2-inch incre- ments	Large, average, small Obese, very stout, stocky, medium, slim Straight (erect) medium, stooped Angular, muscular rounded Bust (for females) flat, medium, heavy  	Exact or Esti- mated in 10- pound incre- ments	Exact or Esti- mated in 5-year incre- ments	Pale, fair, dark, ruddy, sallow, sickly pale, florid (for whites) Light brown, dark brown, dark olive (for blacks) Clear, pimpled, blotched, freckled, pockmarked Make-up — none, light, heavy

Begin by describing the size and shape of the head. Then move to the profile. Mentally divide it into three parts. Describe each third in separate detail and in relation to the whole. (The profile, unless it has a peculiarity, is not as useful as the shape of the face for identifying people.) Then describe the hair. Give both natural and artificial color of the hair if it has been altered. Describe its texture, density, appearance and style. You may use current descriptive terms for hair styles. Wigs, toupees, and hairpieces should be described carefully and in detail. You can often tell if someone is wearing a hairpiece by its difference in texture, color, density, or type from the hair elsewhere on the head. False hair will often be too nearly perfect. And the edges of a hairpiece are often evident under close scrutiny.

When describing the face, give the shape and details of the forehead, eyebrows, eyes, nose, mouth, lips, teeth, chin, and ears. Look closely at the nose. Has it been broken? Does it twist to the right or left? Is it turned up, pendulous, hairy, or deep-pored? Note the color of the eyebrows, eyes, and lips. If makeup is used to modify or enhance the complexion, include this information. When describing females, indicate both natural and artificial contours if you can. Be alert for the use of lipstick to alter or accent the natural appearance of the lips. Note equipment like glasses and hearing aids.

Contact lenses may be hard to see. Watery eyes and excessive blinking sometimes are a hint of contact lenses. Make careful note of special types of eyeglasses like monocles, pince-nez, and bifocals. Do the same for special types of hearing aids.

Go on to describe the rest of the person in this same way, moving always downward. When describing the length of the arms in relation to the rest of the body, keep in mind that an average arm length places the heel of the hand about half-way between the hips and the knees when the arm is hanging naturally. Note oddities or deformities of the hands and fingers in detail. Missing or crooked fingers, for instance, are hard to disguise. They make good first checks of suspects. The same is true for marks and scars. Describe birthmarks, moles, warts, tattoos, and scars by size, color, location, and shape. Be as detailed as you can.





















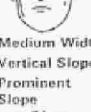

The tone and manner of a person's speech can be an important part of a description. Habitual tone should be noted as low, medium, or loud; soft or gruff; or by other descriptive qualities. State the manner of speaking as cultured, vulgar, clipped, fluent, or using broken English. Identify accents when possible. If the person is not speaking English, try to recognize the language he is using. Note oddities of, or handicaps to, speech: a stutter, a nasal twang, a pronounced drawl, or a mute condition.

Since a person may change his clothing, its descriptive value is limited. But look for dress habits like neatness, carelessness, and style preference. These do not change as readily. Clothing worn by a person at the time of an offense, however, or when the person was last seen, should be described in detail. List this by type: military, civilian, mixed military and civilian, and color. And give the condition of the clothes: clean, soiled, torn, ragged, greasy, or bloodstained.



































Be sure to include remarks about personal appearance. Use terms like neat or untidy; well-groomed or unkempt; refined or rough.

A person's odd mannerisms or traits may form the main or key part of a description. Be alert for feminine traits in a man and masculine traits in a woman. Watch how the person walks, moves, or talks. Does the person show signs of nervousness or indecision? Look for subconscious mannerisms. Is the person often seen scratching the nose, running a hand through the hair, pulling on an ear, hitching up the pants, jingling keys, or flipping coins? Look for facial tics, muscular twitches, or excessive gesturing with the hands. And note any pieces of jewelry being worn.

**NOTABLE SPECIFIC CHARACTERISTICS OF PERSONS**

HEAD	FACE	HAIR	FOREHEAD	EYEBROWS
<p>Size — large, medium, small</p> <p>Shape — long, short, broad, narrow, round, flat in back, flat on top, eggshaped, high in crown, bulging in back</p>  <p>Flat In Back</p>  <p>Flat On Top</p>  <p>Egg Shaped</p>  <p>Bulging In Back</p>	<p>Round square oval broad long</p>  <p>Round</p>  <p>Square</p>  <p>Oval</p>  <p>Broad</p>  <p>Long</p>	<p>Color — blond, brown, red, auburn, black, gray, streaked gray, white; light or dark; natural or artificial</p> <p>Density — thick, thin, medium, sparse</p> <p>Hairline — low, medium, receding, receding over temples</p> <p>Baldness — complete, whole top of head, occipital, frontal, receding, or combined</p> <p>Type — straight, wavy, curly, kinky</p> <p>Texture — fine, medium, coarse</p> <p>Appearance — neat, bushy, unkempt, oily, dry</p> <p>Style — long, medium, short; parted on left, on right, not parted; page-boy, corn row</p> <p>Wig or toupee</p>  <p>Frontal Balding</p>  <p>Wavy Course</p>	<p>Shape — high, medium, low</p> <p>Slope — receding, medium, vertical, prominent, bulging</p> <p>Width — wide, medium, narrow</p> <p>Wrinkles or age lines — none, light, deep, horizontal, curved up or down, vertical</p>  <p>← Receding Slope</p>  <p>Wide Width</p>  <p>Medium Slope</p>  <p>Medium Width</p>  <p>Vertical Slope</p>  <p>Prominent Slope</p>  <p>Narrow Width</p>	<p>Color — and if same or different from hair color</p> <p>Shape — slanted up, down, horizontal from center of face straight, arched, separated, connected plucked penciled</p> <p>Texture — heavy medium, thin</p> <p>Hair length — long</p>  <p>Thin Line</p>  <p>Arched</p>  <p>Straight Connected</p>  <p>Heavy, Long Hair</p>

NOTABLE SPECIFIC CHARACTERISTICS OF PERSONS

EYES	NOSE	MOUTH	LIPS	MOUSTACHE AND BEARD
<p>Shape — sunken, medium, bulging</p> <p>Spacing — wide, medium, narrow</p> <p>Color</p> <p>Crossed, watery, red</p> <p>Eyelids — normal, drooping, puffy, red</p> <p>Eyelashes — color; length — long, medium, short; shape — straight; curled, drooping</p> <p>Makeup — none, light, dark, irregular; color, type, extent</p> <p>Glasses — style; color of frames and lenses, how attached to the face; type — monocle, pince-nez, bifocals</p>	<p>Length — short, medium, long</p> <p>Width — thin, medium, thick</p> <p>Projection — long, medium, short</p> <p>Shape of base — turned up, horizontal, turned down</p> <p>Juncture w/forehead — flat, small, medium, large</p> <p>Line — concave, straight, convex (hooked), Roman, aquiline</p> <p>Nostrils — medium, wide, narrow; large or small; high or low; elongated or flaring</p> <p>Oddities — broken, twisted left or right, turned up, pendulous, hairy deep-pored</p>	<p>Size — small, medium, large</p> <p>Expression — stern, sad, pleasant, smiling</p> <p>Oddities — twitching, habitually open</p>	<p>Shape — thin, medium, thick (frontal); long, medium, short (profile)</p> <p>Color</p> <p>Position — normal; protruding lower, upper, both</p> <p>Appearance — smooth, chapped, puffy, loose, compressed, retracted over teeth, moist, dry</p> <p>Oddities like hair lip</p>	<p>Color — and if same or different from hair color</p> <p>Style</p> <p>Shape</p> <p>Grooming</p>
 <p>Narrow</p>  <p>Close Together</p>  <p>Puffy Eyelids</p>  <p>Bulging, Wide Spaced</p>  <p>Glasses</p>	 <p>Aquiline</p>  <p>Roman</p>  <p>Convex</p>  <p>Concave</p>	 <p>Small</p>  <p>Medium</p>  <p>Large</p>  <p>Narrow</p>  <p>Medium</p>  <p>Wide</p>  <p>Short</p>  <p>Turned Up</p>	 <p>Thin</p>  <p>Medium</p>  <p>Thick</p>  <p>Upper Protruding</p>  <p>Lower Protruding</p>  <p>Distance between upper lip and nose</p>	 <p>Straight</p>  <p>Curved</p>  <p>Divided</p>  <p>Handlebar</p>  <p>Mandarin</p>  <p>Rounded</p>  <p>Double Pointed</p>  <p>Squared</p>  <p>Van Dyke</p>  <p>Henry VIII</p>  <p>Side Whiskers</p>

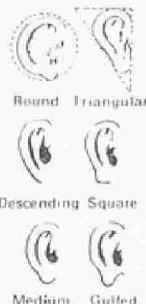
NOTABLE SPECIFIC CHARACTERISTICS OF PERSONS				
TEETH	EARS	NECK	SHOULDERS	BACK
Color — very white, normal, stained, gold Size — small, medium, large Shape — receding, normal, protruding, even, pointed Condition — broken, decayed, false, missing, w/gaps	Size — small, medium, large Shape — oval, round, triangular, rectangular Lobes — descending, square, medium, gulfed Separation from head — close, normal, protruding	Size — short, long Shape — straight, curved, thick, thin Adam's apple — large (prominent), medium, small	Size — large, medium, small; narrow, medium, broad Shape — square, round, level, one side lower (frontal); straight stooped, slumped, humped (profile)	Rear view — straight or curved Profile — straight, curved, humped, bowed
<b>CHIN</b>	Setting — low, normal, high (the corner of the eye is usually in line w/upper third of the ear) Hearing aid — color; which ear; located behind or inside ear, w/cord, w/o cord	<b>CHEST</b>	<b>ARMS</b>	<b>HIPS</b>
Shape — receding, jutting (profile) short, medium, long (frontal) Size — small, large, pointed, square, dimpled, cleft, double		Front view — broad, medium, narrow Profile — deep, flat, medium	Length — long, medium, short Musculature — slight, medium, heavy	Front view — broad, medium, narrow Profile — small, medium, large
<b>CHEEKS</b>		<b>TRUNK</b>	<b>HANDS</b>	<b>LEGS</b>
Shape — full, bony, angular, fleshy, sunken, flat Placement — high (prominent), medium, receding Make up — heavy, light, color, placement		long, medium, or short in relation to body size	Size — small, medium, or large in relation to body size Oddities	Length — long, medium, or short in relation to rest of body (average legs plus hips equal about half the body length) Shape — straight, bowed, knock-kneed Musculature — slight, medium, heavy
		<b>WAIST</b>	<b>FINGERS</b>	<b>FEET</b>
		small, medium, large	Length — long, medium, short Shape thin, medium, thick (stubby) Deformities — missing fingers, disfigured nails	Size — small, medium, or large, in relation to rest of body Deformities — pigeon-toed, flat-footed, club-footed
	<b>ABDOMEN</b>	flat, medium, protruding		

## OBJECTS

The pattern of observation you use to describe objects is like the pattern you use to describe people. You go from the general to the specific. And you use this same pattern when trying to find objects to match a description already built.

Start with general features that clearly define the broad category of the object. This prevents its being confused with objects of

other classes. Note its type, size, and color. Look for other general features that are easy to discern and that may help give quick, sure recognition. Then go on to describe the object's specific features that set it off from all other like items. Does the car have a sun roof? Is the radio or typewriter portable? Next, look for damage or alterations. Last, look for serial numbers or other identifying marks or labels.

Your observation and description should follow a general flow. Move from top to bottom, or from front to rear, or from left to right. Distinguishing marks, scratches, alterations, damaged parts, worn areas, signs of repair, faded paint, serial numbers, identifying markings, and missing parts should be noted in detail. For example, when observing and describing a typewriter, begin with the brand name. Then go on to list it as "nonportable, model 17, 11-inch carriage, light gray with ivory keys and black lettering, serial number J17-123456." Include remarks like "Letter H key is bent and strikes below the line. Numeral 5 key is bent and sticks in the forward position. When struck, it must be returned manually to the rear position." Whatever the object, you follow the same procedure.

#### DESCRIPTION OF A MAN'S SUIT

Brand XXXX; dark blue; wool worsted; coat size 42 regular; half-lined with dark blue silk; coat lapels of wide width; single-breasted with three black buttons; four small black buttons on each sleeve; small tear in lining on right outside coat pocket; trousers size 33-inch waist, 34-inch length; unlined; not pleated; cuffs, 1 1/2 inches wide; and cleaner's mark JHO stamped in black on the inside of the waistband.

#### EVENTS

If you are present when an unlawful event occurs, you must observe it systematically and quickly. Take in the important factors of time, place, persons, objects, and actions involved, as well as the immediate results of the event. These factors are involved in the essential questions of who, what, when, where, and why. But in most cases you arrive at the scene of an incident after the crime has occurred. Hence, you seldom see an event as it takes place. Your observation of connected actions after an event, however, may give major clues to what did take place.

Small but important actions or events often provide an important lead for an investigation. Remarks, states of excitement, gestures, looks of concern, and unlikely claims of lack of knowledge can all be clues.

You may get leads from such things as the way a fire burned, the presence of certain fumes or odors, the sound of a voice, or the warmth of a body. Such deduction may aid in reconstructing an event's cause, start, or progress. You must recognize related acts or conditions and understand them correctly.

Your description of an event must be as complete as circumstances allow. It should contain the facts of time, place, order of action, objects and persons involved, and what happened because of these factors. To get a thorough and logical description of an event, think about it in terms of your observations. Consider statements made by witnesses and suspects. And evaluate the physical evidence from the crime scene. Support your description of an event with sketches and photographs if they are needed.

#### PLACES

To show the exact scene of an incident or crime, you may have to make detailed observations of places and locales. Your purpose may be to connect the place to an incident. Or it may be to connect the place to information given by a witness.

Your descriptions should cite the elements you observe. Your goal is to give a concise and easily understood word picture of the scene. Sketches and photographs, when appropriate, will add to your word description. Your pattern of observation will depend on whether you are looking at an outdoor scene or an indoor scene.

When observing and describing outdoor scenes, go from the general to the specific. Look for natural or man-made landmarks. Note the general scene and its relation to roadways, railways, and/or shore lines. Use them to pinpoint the general site. Pinpoint the exact site in relation to fixed or semifixed features. Use features like buildings, bridges, or power line poles. View outstanding objects or features within the scene. Check details of the scene and items of high interest. Some outdoor sites may not have such landmarks. Then you must mentally assign boundaries to the area. Use boundaries that are neither too far apart or too close together. A common sense approach is a must.

### DESCRIPTION OF AN OUTDOOR SCENE

The incident took place in Anniston, AL, near the intersection of Quintard and First Streets. The exact location was the east sidewalk of First Street, 10 feet due north of a fire hydrant. The hydrant is on the east side of First Street about 20 feet north of the corner (curb) of Quintard and First Streets.

**Observing and describing an indoor scene is easier.** Indoor scenes have obvious

and definite boundaries like walls, hallways, and basements. But because an indoor area often contains many objects, it is very important to use a methodical pattern of observation.

First, note the location of the place to be observed. Say if it is at the front or rear of the building and at what floor level. Then check the distances to stairways, entries, elevators, or the like. Next, get the room number or other designation. Observe details near entries to the area that is the specific point of concern. Note objects located within the area. Last, get the exact location as it relates to other objects of concern.

### DESCRIPTION OF AN INDOOR SCENE

The incident took place in Room 204 of the Union Hotel, at 1052 Moore Avenue, Anniston, AL. Room 204 is on the second floor of the hotel, directly above the Moore Avenue entrance. The room is reached by the elevator to the left, or the stairway to the right, of the Moore Avenue entrance.

The door to Room 204 is wood, covered with red leather-like material. The room number is printed on it in 2-inch black letters. Inside, and to the immediate left of the entrance, is a dark upright piano. On the piano stands a large white vase and two single brass candlesticks with red candles. Against the left wall, facing the center of the room, is a dark blue standard-size sofa. On the sofa are two red and one white triangular pillows. At each end of the sofa is a dark brown end table with glass top. Each end table supports a 3-foot high brass table lamp with light blue shade. The lamp on the table nearest the door is overturned and rests partly on the sofa arm. An empty drinking glass is on the opposite end table.

In the wall opposite the entrance are two double-sash casement windows. The windows are furnished with dark red brocade drapes closely drawn. Between the windows is a movable serving bar. The front of the bar is covered with red leather-like material. On the left end of the bar stands an empty water pitcher and two empty drinking glasses. Near the center of the bar is one drinking glass containing about 1 1/2-inches of light brown liquid. On the right end of the bar is an empty glass bowl about 3-inches deep and 10-inches in diameter. Under the bar is a square wooden wastebasket containing three empty bottles and many glass fragments. Next to the

wastebasket is a wooden case containing nine empty assorted soft drink bottles. Six bar stools are in front of the bar. The stools have round seats covered with red leather-like material. Each has three black metal legs fastened to the floor with screws. The entire wall behind the bar and between the two windows is mirrored. At either end of the mirror are three glass shelves on which rest numerous inverted drinking glasses. Beneath the mirror is a glass-topped wooden shelf 10-inches wide. This shelf contains seven open and four sealed bottles of what appears to be intoxicants.

On the wall to the right of the entrance, 3 feet from the opposite wall, is a door leading to a bathroom. Eight feet along this wall from the bathroom door is a door connecting with Room 206. This door is locked at the time of observation. Between these two doors is a dark brown table with a wooden top about 2 feet by 2 feet in size. There is one dining-room chair upholstered with maroon leather-like material at the table.

Three tables of this same type are in the center of the room. Two upholstered dining chairs are at each. On each of these center tables, and on the table on the right side of the room, are two plates with partially eaten food servings.

At a point 10 feet from the entrance and 7 feet from the table near the right wall is an overturned dining chair. Its right front leg is broken but still attached to the chair. The chair leg is stained with a substance that appears to be blood.

In the center of the ceiling is a black brass, three-light chandelier. The floor of the room is completely covered by tan carpeting.



## OBSERVATIONS AND DESCRIPTIONS BY WITNESSES

Observations, descriptions, and identifications made by witnesses can be highly useful to you as an investigator. Some persons may be able to give a concise and fact-filled account of what they have seen. But, in most cases, you must use skillful and patient questioning to help a witness to recall details of persons, objects, places, and events. Your questions will evoke the details which help give meaning to his observation.

It is important that you talk with witnesses as soon as possible after they have made their observations. Do this before they have time to talk to others or to change their observations, consciously or unconsciously, to fit a pattern of other things they may have seen or heard. Imaginative persons often use conjecture to fill in the gaps in their knowledge of an incident. This is particularly true if they later learn that the incident is important in an investigation. It is also important for you to evaluate a witness's information and compare it with all related data before you use it to investigate further. And you must be aware of, and make allowance for, the many factors that may influence a person's understanding and retention of the details he relates. You also need to keep in mind how conflicts can occur in statements made by different witnesses.

When obtaining a description from a witness, learn, if you can, of any influences affecting their understanding of what they saw. Find out if there are influences that might cause them to give false answers. Some witnesses may purposely withhold information so they will not become involved.

Most investigations call for quick action. Thus you must often proceed without full background data. This may make it hard to know what influences someone. But you can take steps to help tell the extent of these influences. You can develop the use of a pattern of recall to help get a clear word picture. It will improve your technique of getting descriptions of observations from others. You can talk to witnesses briefly before questioning them. This will put them at ease and help get them to talk freely. You may discover enough about them to know what may affect their interpretation of what they have seen. And you can ask the witnesses to repeat their descriptions. This may reveal discrepancies made on purpose or by incomplete observation. Ask about these flaws in an attempt to get a better description. Your questions may even lead a witness to admit he distorted the truth. A witness who lies or hides information often makes unconscious slips that you will note.

## IDENTIFICATION

Having a witness or victim identify a person, a place, an object, or an event is the way you relate that factor to an incident. You must conduct identification efforts in a way that precludes errors or injustice. Before an identification is begun, make sure the witness has made as complete a description as he can. This will help avoid false identifications and reduce the chance for error. Let the witness identify a person or an object from among a *group* of like persons or objects. Showing a witness one weapon or one person to identify may confuse him. He may give a mistaken identification because the weapon or person was shown to him by you. To identify a place, have the witness describe its general location in relation to known

landmarks. Next, have him describe it in detail. Then he should be asked to take you to the scene.

## COMPOSITES

Composite photographs or sketches are often used to help identify persons. Composites are developed from separate photographs or sketches of foreheads, eyes, noses, mouths, chins, or other facial features. The witness selects the example which most nearly looks like the particular facial feature of the person to be identified. But do not show a witness a photo lineup before having him help develop a composite. It may influence his memory of the subject.

## COMPOSITE PHOTOS MADE WITH A COMMERCIAL KIT

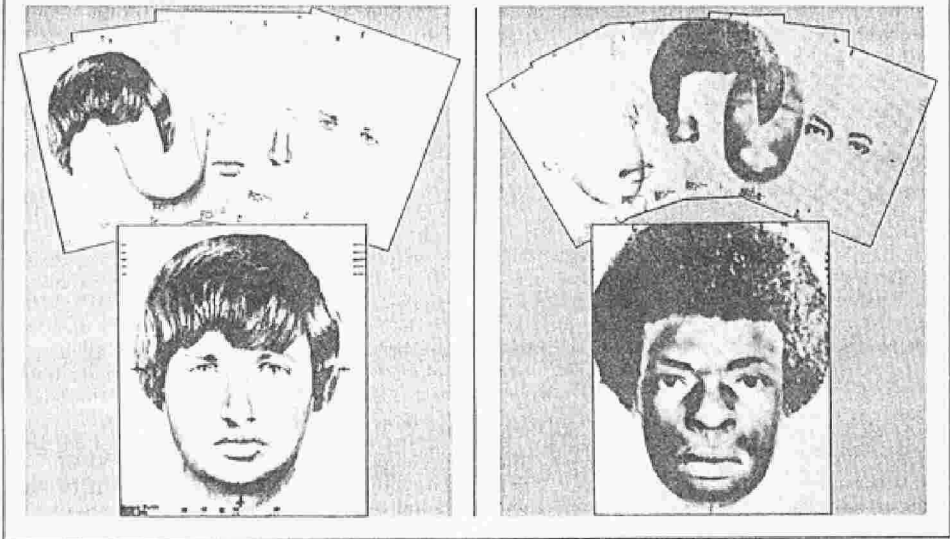

Commercially manufactured kits can be used to make composite drawings or photos from verbal descriptions. The drawings from such a kit can resemble a person so closely it removes others from suspicion. And the kit model that uses true photos of facial features, hairstyles, eyeglasses, hats, and the like produces realistic photo-like composites.

If photographs or sketches of separate features are not available, many photographs of different persons or objects may be used. Have the witness pick out the features which most closely look like the person or object to be drawn. Or have an artist sketch a likeness of persons or objects from descriptions given by one or more witnesses. Even this kind of drawing or portrait may be useful to an investigation.

### LINEUPS

Another way to identify suspects or objects is to use a lineup. A lineup can reduce mistakes and eliminate false identification of persons and objects. And it can avoid leading or misleading a witness.

*A lineup must meet legal requirements.* There are rules for picking people for the

lineup, their actions before and during the lineup, and control of the witnesses/victim. Tell the witnesses or victim of the rules that you must enforce.

For a lineup to be legal, it must meet the test for fundamental fairness. That means it cannot be impermissibly suggestive. *It must be composed of similar subjects having similar characteristics.* Anything which would hint that one of the participants is "the one" would be a defect in that lineup.

The location of a lineup is up to you. But it should be held in an area that is away from public view to keep from drawing unwanted attention or disturbance. If you are having a lineup of people, you need enough room for about six people to stand side by side. There is no specific number of participants you are required to have in a lineup. But having six or more persons, photographs, or objects is a number that works well for all three kinds of lineups. You may hold a lineup of objects at the site of an offense or in some other suitable place. Pick a place where one is likely to find such items. This may mean putting a car in a parking lot with other cars or putting a coat in a closet with other coats.

## PART THREE

**OBTAINING AND RECORDING PHYSICAL EVIDENCE**

## CHAPTER 7

**Fingerprints**

Fingerprint evidence is the most positive investigative means of identifying people. Every fingerprint is unique. Fingerprints form on a person before birth and remain unchanged until the body decomposes after death. Fingerprint impressions often look alike. But when they are examined closely, their differences can prove the prints to have been made by different fingers. And the opposite may be true. Prints from the same finger may look different because the pressure used to make them differed. Or they may look different because the curve of the surface differed. Yet examination by a qualified examiner can prove the prints to have been made by the same finger.

Positive identification or elimination of fingerprints can only be made by trained and qualified fingerprint examiners. Examiners identify prints by making the qualitative and quantitative comparisons of one friction ridge print with another. They compare the separate

**FINDING AND PROCESSING LATENT PRINTS**

"Latent" prints are chance or unintentional prints found on items of evidence or at a crime scene. Some prints can be plainly seen. They are made by a finger coated with a foreign substance like blood, grease, or dirt. Some prints are "plastic impressions" imprinted in pliable substances like butter, candles, putty, and semidry paint. Other prints, invisible or barely visible to the eye, are made by the natural body secretions of the hands and fingers.

The visibility of latent prints depends on the physical condition of the person who left the print, on the surface of the object, and on the angle of reflection of the light by which

<b>CONTENTS</b>	
	Page
<b>FINDING AND PROCESSING LATENT PRINTS</b> .....	73
<b>PRESERVING PRINTS</b> .....	75
Powdering .....	75
Lifting .....	75
Chemical Processing .....	76
<b>OBTAINING PRINTS OF LIVING PERSONS</b> .....	76
Rolled Impressions .....	77
Plain Impressions .....	78
Palm Prints .....	78
Major Case Prints .....	78
Problem Prints .....	79
<b>OBTAINING PRINTS OF DECEASED PERSONS</b> .....	79

ridge characteristics and their relationship one to another. They can do this from impressions of any area of friction skin.

they are viewed. The visibility of prints also depends on the time that has passed since they were placed, the amount of heat to which they have been exposed, and other factors. The amount of time they stay on an object is affected by atmospheric conditions, air currents, and humidity. But even when the object has been exposed to adverse conditions, it may be possible to obtain prints.

Attempts to obtain prints should be made in *all* cases. Smudges lacking ridge features may have foreign substances like grease or blood on them. Although not serviceable as latent prints, they may provide other trace evidence.

Photographing prints found at crime scenes can safeguard fingerprint evidence. Taking photographs before attempting to preserve prints can offset damage which can sometimes occur in the preservation process. The photographs are also useful in the

preparation and presentation of fingerprint evidence. After photographing fingerprints found at a crime scene, an enlargement can be made at the crime lab. Enlargements can be very useful in studying a print and comparing it with other prints.

## FINGERPRINT PATTERNS AND CLASSIFICATIONS

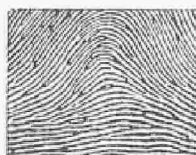

**PLAIN ARCHES**

In plain arches the ridges enter on one side of the impression and flow or tend to flow out the other side with a rise or wave in the center.

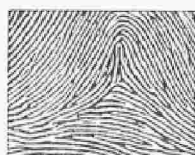

**TENTED ARCHES**

Tented arches are similar to plain arches with the exception that the ridges in the center form a definite angle, or one or more ridges at the center form an upthrust, or they approach the loop type, possessing two of the basic characteristics of the loop but lacking in the third.

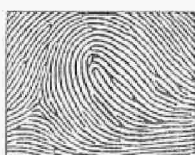

**ULNAR LOOPS**

Ulnar loops are those types of patterns in which the loops flow in the direction of the little fingers.



**RADIAL LOOPS**

Radial loops are those types of patterns in which the loops flow toward the thumbs.



**DOUBLE LOOP**

The double loop consists of two separate loop formations, with two separate and distinct sets of shoulders and two deltas.



**PLAIN WHORL**

A plain whorl has two deltas and at least one ridge making a complete circuit, which may be spiral, oval, or any variant of the circle. An imaginary line drawn between the two deltas must touch or cross at least one of the recurring ridges within the pattern area.

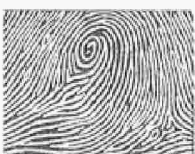

**CENTRAL POCKET WHORL**

The central pocket whorl consists of one or more recurring ridges, or an obstruction at right angles to the inner line of flow, with two deltas between which an imaginary line would cut or touch no recurring ridge within the pattern area. The inner line of flow of a central pocket loop is determined by drawing an imaginary line between the inner delta and the center of the innermost recurve or looping ridge.



**ACCIDENTAL WHORL**

The accidental whorl is a pattern with two or more deltas, and a combination of two or more different types of patterns exclusive of the plain arch. This classification also includes those exceedingly unusual patterns which may not be placed by definition into any other classes.



## PRESERVING PRINTS

Prints made visible by a foreign substance on the fingers often need only be lifted with print lifting tape. Or if the prints are on a small object, the whole object may be held as evidence. But latent prints made by just the normal secretions of the skin often have to be processed in a special way before they can be seen and preserved. The most common means is by powdering or chemical treatment.

Prints needing dusting powder to develop should be photographed before lifting. Prints found in dust should be photographed and then lifted. They should not be powdered, as this will destroy them.

### POWDERING

Fingerprint powders are supplied in field kits in several colors, but black and white are used the most. Choose the powder that best contrasts with the background. These commercial powders have been developed over many years. They are dependable and of the right composition.

Some fingerprint equipment includes fluorescent powders to develop latent prints on multicolored surfaces. These powders are not often found in issued kits. They require a source of ultraviolet light. Long-wave ultraviolet light should be used, as short-wave ultraviolet light is harmful to the eyes and skin. And you must wear protective goggles and clothing. The choice of powder depends on whether the latent print is developed for photographing or lifting. As latent prints are normally lifted, the use of ultraviolet powders is rare.

To preserve a print with powder, first check for a test print in the area selected. Lightly brush it with powder to see if any unseen latent print is actually present. Then the surface can be wiped clean and the test print made and processed.

Fingerprint powder can be applied with fiberglass, camel hair, and feather brushes. A magnetic wand is used with magnetic powder. A large piece of cotton can be used for developing latent prints over a large area.

Pour some of the powder out of the container onto a sheet of paper. Just touch the

tips of the brush to the powder. Then shake off the excess powder. The key to proper print development is to use a small amount of powder and a delicate touch. Using a smooth stroke, guide the brush over the suspected area or over the barely visible print. Get enough ridge detail to see the direction of flow of the ridges. The brushing, if continued, should follow the ridge flow. When the ridge detail is complete, photograph it. After the photograph you may use more powder to make the print more visible. Then photograph it again. Protect the print with lifting tape before sending it to the lab.

Sometimes the powder sticks to the object on which the print is found. If brushing will not remove the excess powder, make two lifts. The first lift will remove the excess powder. The second will preserve the fingerprint for identification needs. A latent print may be enhanced after the first lift by added processing with brush and powder.

If you are in the field without proper powders, you can use soot as a field expedient. Pass nonflammable objects through the smoke of a burning piece of pine wood or a wad of masking tape. A black, even deposit of soot will form on the object. Careful brushing will often yield latent prints.

### LIFTING

The most common means used to lift latent prints are rubber lifters and transparent lifting tapes. Rubber lifters are better than transparent lifting tape for taking prints from curved or uneven surfaces. Transparent lifting tape has the advantage of presenting the lifted fingerprints in the correct position; the print is reversed on the rubber tape. Both tapes and lifters are available through General Services Administration supply sources. Ordinary transparent tapes used in homes and offices is not really suitable for lifting fingerprints. However, these tapes may be used as a field expedient. Other lifting materials are also available. White and black opaque lifting tapes are applied like rubber lifters. Hinged lifters with transparent tape and white and black backings are used like lifting tape.



Dust with powder; photograph with a ruler; apply transparent tape, making sure air bubbles do not form, then lift.



Rubber lifters store well and come in both black and white for use with different colored powders. They are well suited to use on surfaces like doorknobs. Use a lifter large enough to cover the print and leave lots of room. Remove the plastic cover of a rubber lifter with care in one steady movement. Any pause will result in a line being left on the lifter. In most cases, powder on a print will not stick to the line, thus ruining the print. Place the adhesive side of the lifter to the powdered print. Press it down evenly, then peel the lifter from the surface on one smooth, even motion. Place the plastic cover of the lifter over the lifted print to protect it.

Using the transparent lifting tape available in dispensers speeds up the lifting process. Prints on transparent lifting tape should be mounted on material of a color that contrasts with that of the lifting powder.

When lifting a print with either manner, use care to halt air bubbles forming under the lifter. Keep a quarter twist on the tape with one hand while rolling it flat with the other to help prevent air bubbles.

## OBTAINING PRINTS OF LIVING PERSONS

Fingerprints impressions taken directly from a person's fingers for the purpose of identification must be uniformly clear and visible. It is not hard to take good, clear fingerprints. A good fingerprint impression is dark gray in color and free of smudges. All that is needed to obtain good prints is practice.

## CHEMICAL PROCESSING

All chemical processing of fingerprints is done at the laboratory. Lab technicians are trained to use many chemical mixtures to process the evidence. And they are trained to use the techniques required by federal regulations for the handling of dangerous, toxic chemicals.

Latent prints on paper products should be developed with chemicals. Paper acts as a blotter, absorbing skin secretions when touched. Thus, the latent prints will not rub off paper as they rub off a nonporous surface. The amount of contact and pressure by the fingers are the two variables that affect these latents the most. To develop the prints, the paper is exposed to chemicals that react with the skin secretions of the print residue. The chemical processes depend on the presence of mineral or organic matter in perspiration. Perspiration composition differs from person to person and from time to time in the same person. This difference accounts for the uncertain and frequently spotty development of these processes.

Have the subject sign the fingerprint card. It is not needed nor desired that you advise persons of their legal rights just to take their fingerprints. Have the subject wash his hands to remove any dirt particles. Make sure that the fingers are free of lint from the towels used to dry the hands. Gather your equipment together and ready it for printing.

In addition to fingerprint cards, you will need—

- A fingerprint card holder.
- Ink (printer's ink or any special fingerprint ink).
- A rubber ink roller.
- Plate glass (approximately 12" x 6" x 1", fixed to a base).

Place a small dab of ink on the plate glass and roll until a thin, even film covers the surface. It helps to place a white card under the glass to check the ink's thickness while rolling it out and while inking fingers. Secure the fingerprint card in the holding device, and the equipment is ready to use.

The steps for inking fingers and the steps for making impressions on the card are the same. Each finger is rolled through the ink on the glass and then that finger impression is rolled on the fingerprint card. All rollings should be made in single movements. Do not roll back and forth. The pressure should be just enough to apply an even coat of ink on the finger and a clear image on the card.

After the procedure is complete, fill in the data on the fingerprint card. Sign the card or paper for identification. *This signature is important in legal proceedings.*



Grasping the top of the hand and touching the tip of one finger to keep it extended, roll the extended finger through the ink, making sure the ink reaches past the first knuckle.

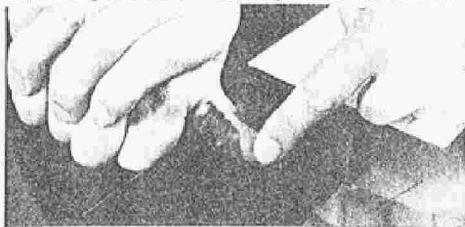

Still holding the subject's hand, roll the inked finger onto the card, printing the impression in a single movement. Repeat for each finger on that hand.

## ROLLED IMPRESSIONS

Rolled impressions are made to show the entire friction surface of the finger or thumb, from the tip to one-fourth inch below the first joint. They are made by rolling the finger or thumb from nail edge to nail edge. This surface gives all the needed ridge characteristics for correct classification. (Classification is the means by which a set of fingerprints may be filed and then retrieved in the future.)

There is a specific means of rolling the subject's fingers or thumbs in the ink and on the fingerprint card to give a good impression. You roll the fingers or thumbs from "awkward to comfortable." To see what is meant, hold your hands in front of you with the backs of your hands together. Now roll them around so that the palms are together and thumbs are up. You will see that the right hand moved clockwise and the left hand counterclockwise. This is the direction the fingers on each hand should be moved. Thumbs are moved in the opposite direction of the fingers.

When you take prints, grasp the top of the subject's hand to make sure that the finger to be printed is extended. The roll is a single movement and with only enough pressure to





give a clear print. Tell the subject to look away from the fingerprint card and to try not to "help" the roll. This will reduce smudging and give a clean impression.

**PLAIN IMPRESSIONS**

Plain impressions verify the order of the rolled impressions and show characteristics that are sometimes distorted in rolled prints. Plain impressions are made on the card by just pressing the four inked fingers on the card at a slight angle. They should show from the tips to one-fourth inch below the first joint. Thumbs are then printed by inking and pressing them on the block next to the plain finger impressions.

Have the subject hold his fingers straight and stiff. The hand should be level with the wrist. Grasp the wrist with one hand and press the fingers onto the cards with the other hand. Then allow the subject to clean the ink from his fingers.

**PALM PRINTS**











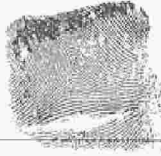

You may need to obtain palm prints from a subject at times. This is because the whole hand makes a distinctive impression. These prints are sometimes found on evidence or at a crime scene. The biggest problem with making palm prints is that often the hollow part of the palm is not properly printed.

The best way to record palm prints is to have the printing paper wrapped around a tubular object. Place the heel or base of the subject's palm on the tubular object and roll the print in a pulling motion from the heel of the hand to the fingertips.

**MAJOR CASE PRINTS**

Major case prints are a complete set of prints. They include the record prints of inked finger, palm, and sole impressions taken for identification needs. And, in addition, they include edges of the hand,

**ROLLED AND PLAIN IMPRESSIONS ON A FINGERPRINT IDENTIFICATION CARD**

RIGHT HAND					
1. Thumb	2. Index finger	3. Middle finger	4. Ring finger	5. Little finger	
					
LEFT HAND					
6. Thumb	7. Index finger	8. Middle finger	9. Ring finger	10. Little finger	
					
Left Hand Four fingers taken simultaneously		Note amputations		Right Hand Four fingers taken simultaneously	
		Thumb Plain Impressions			
					

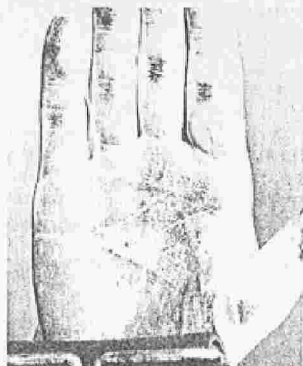

Ink the hand, place the heel of the hand on the paper-wrapped tube, and roll, pulling the hand across the tube from heel to fingertips.

fingertips, and the entire finger. In effect, prints are made of all parts of the hand to include the tips, palm, sides of the fingers, and sides of the palm. Sometimes prints of the feet are also included. Major case prints often help in forgery cases. The print of the side of the hand leaves an impression like that of a hand in the writing position.

### PROBLEM PRINTS

Excessive perspiration may cause inked impressions of many persons to blur. Wipe each finger with a cloth and then quickly ink and roll it on the fingerprint card. Follow this process with each finger. You may also wipe the fingers with alcohol or other drying agent. Some people have dry, rough hands from their work. Rubbing the tips of the fingers with oil or creams can often make them soft enough for clear, unsmudged

prints. If the ridges are fine and small and the skin is soft, holding ice against the fingers sometimes helps.

If the hands and fingers are deformed, normal printing steps cannot be followed. Apply the ink directly to the fingers with a spatula or small roller. Then rotate a square piece of paper around the finger. When an acceptable print has been made, the square is taped to the proper box of the fingerprint card.

If there is an extra finger (usually a "little" finger or a thumb), the innermost five are printed as usual on the card. The extra digit is then printed on the reverse of the card. Print webbed fingers as well as you can in the rolled and plain impressions. And if a finger or a fingertip is amputated, note that fact in the proper box. (Example: "AMP" 1st joint, FEB 1943 or "TIP AMP.")

### OBTAINING PRINTS OF DECEASED PERSONS

Major case prints are always obtained of deceased persons connected with an investigation. The prints are used to identify or eliminate latent print evidence and to identify the deceased. When the body is in an Army mortuary in the graves registration system, graves registration can provide the major case prints.

Printing deceased persons may be done before rigor mortis has set in, after rigor mortis, or after decomposition has begun.

The means used to take the prints depends on the conditions of the fingers and your ingenuity. The process of inking the fingers and rotating a square paper on the finger might be used. This works best with the recently dead or after rigor mortis is gone. When rigor mortis is present you may have to straighten the fingers. This can be accomplished by pressing down on the middle joint of the finger. You might dust the fingers and palms with fingerprint powder and lift the prints with tape or rubber lifters.

This often works well to obtain difficult record prints. Be sure to mark each lift.

The hardest prints to obtain are those from a body which has begun to decompose. It may require techniques beyond your expertise, especially when the hands are badly charred or decomposed. In such cases, the hands or fingers should be sent to the laboratory for identification by laboratory personnel. But

never send a portion of the body to the lab without first contacting the lab for guidance.

When needed, and with SJA advice, the hands or fingers may be amputated by a surgeon. Before amputation takes place, contact your USACIL to learn the best method of processing body parts. Put each body part in a separate bottle and be sure that each bottle is properly identified.

## CHAPTER 8

## Casts and Molds

**Knowing how to make casts and molds can help you protect evidence.** The impression of a footprint at a crime scene might be evidence linking a suspect to that scene. But to learn if an imprint is evidence, it must be examined and compared with other evidence. And to be useful evidence, it must be able to be retained for submission, if needed, in court. Impressions of most footprints, tire prints, and the like are fragile. Their evidence value can be destroyed by time, the elements, or the process of being collected. They must be preserved in their original state to be useful. This is done by making casts and molds.

Casts and molds of imprints can be used for field comparisons. And, more importantly, they can be sent to the crime lab to be examined. Lab specialists will look for signs of class marks and individual marks that may have been on the item making the imprint. Class marks are marks or lettering made by a manufacturing process.

## CONTENTS

	Page
RECORDING IMPRESSIONS .....	81
PREPARING IMPRESSIONS .....	82
CHOOSING YOUR MATERIAL .....	82
Casting with Plaster, Dental Stone, or Dental Compound .....	83
• Casting Under Water .....	84
• Casting in Snow .....	84
Casting with Silicone .....	84
Casting with Liquid Sulphur .....	84
CASTING DIFFICULT IMPRESSIONS .....	84
Tool Marks .....	84
Tire Impressions .....	85
COMPLETING THE CAST .....	85
PACKAGING .....	86
MOLDING .....	86

Individual marks are marks unique to an item. They are made by the cuts, tears, and uneven wear of daily use. It is the presence of these marks that will allow the examiner to make a positive or negative identification.

## RECORDING IMPRESSIONS

**STEP 1** The first step in recording an imprint is to protect it from destruction. This may mean covering it with an object like a trash can lid or cardboard box if it is small. In a large area, this may mean roping off the area and having guards posted. The imprint must also be protected from on-the-scene comparisons. *Comparisons must be done only by the lab.* For example, when a suspect's shoe is found before a cast is made of the imprint, it is human to want to compare them. But if anyone places the shoe in the print, he may contaminate the print. This could make an identification invalid in court.

**STEP 2** After protecting the imprint, it must be photographed. First, make an area photograph. This places the print in relation to other objects. Then, take a closeup of the print. All prints should be photographed with a ruler in place before developing or lifting the print.

**STEP 3** Make sure the location of the imprint is shown in the crime scene sketch. Measurements, too, should be included. And show details like trademarks, nail holes, cuts, and scars in the sketch. Then make sure the measurements and other data are in your notes. Now you are ready to make a cast of the impression.

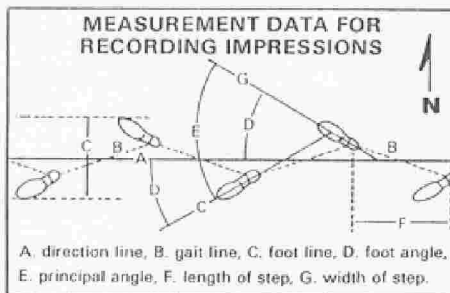

## PREPARING IMPRESSIONS

To obtain a good cast it is often necessary to prepare the imprint. If a print is found outdoors, check to see if any particles have blown into it. These should be removed carefully. Use a syringe to blow away dust that has gathered. Use a pair of tweezers or a pocket knife to take out small stones. A syringe also can be used to withdraw water from the imprint. Or water can be drained by cutting a small channel at one side of the print. Be careful to not destroy parts of the print.

Make a practice cast of your own shoe print before trying to make the evidence cast. Check it to see if the soil is cohesive enough to have made a good print. In sandy and loamy soils the particles may lack cohesion, making the print fragile. If so, the print should be strengthened to support the weight of the casting material. This will keep fine detail from being destroyed. You can strengthen the print by spraying it with a plastic spray or lacquer. Hair spray and paint spray also may be used. Spraying directly on the print may damage details. Instead, direct the spray against cardboard or other material. This

will cause a fine mist to settle gently into the print. Let dry, then spray again. The number of coats you will need can be determined by examining the test print. Three to ten coats in sandy soil is often enough. When the strengthening spray has dried, spray a mist of light oil or silicone on the print. The oil will make it easier to remove the cast.

Sprays are used to make a print solid; they are not always needed in the process. If a print is in solid, earthy material, strengthening preparation is not necessary. Likewise, if a print is found indoors in dust, no preparation may be required. Instead, use the method for preparing fingerprint impressions.

When you are ready to cast, place a retaining wall around the print. This confines the casting mixture. And it allows the cast to be built to the desired thickness. The wall may be made of earth or other material. Old venetian blind slats make good retaining walls. If you make a permanent wall, one you can reuse, give it a coat of oil. This will let it be removed from the cast with ease.

## CHOOSING YOUR MATERIAL

Dental stone takes good impressions of foot and tire prints. Plaster of paris and dental compound also can be used. These materials are most useful for imprints in dirt, mud, sand, or snow that do not show fine detail. When microscopic detail is needed, something other than these must be used. Liquid sulphur gives very fine details. But it is not as readily available as dental stone or

dental compound. Dental stone and dental compound are available through supply channels or post health facilities.

Latex rubber can be used to reproduce faint prints on linoleum and fingerprints developed with powder. However, the prints on the latex have been known to fade. Silicone rubber can be used to cast

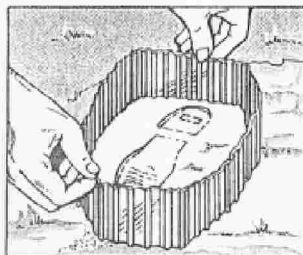
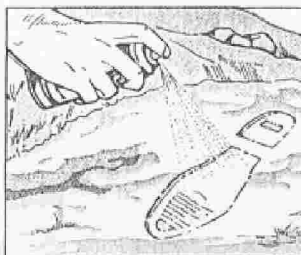
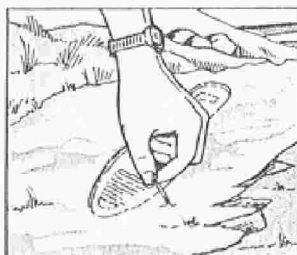

Remove loose debris, spray to stabilize loose dirt, then surround with a form to confine and build up the mixture.

fingerprints found in putty and caulking around window panes. Silicone rubber is more expensive than plaster or compound. But casts can be made more quickly with silicone. Water or heat is not needed. The casts are flexible, which keeps them from breaking during handling or shipping. And the silicone freezes at very low temperature, which makes it useful in casting prints in the snow. Epoxy casting resin may be used to make a "positive" from the silicone rubber impression.

### CASTING WITH PLASTER, DENTAL STONE, OR DENTAL COMPOUND

When casting in plaster, dental stone, or dental compound, it is best to use a thin mixture in the print at first. This helps to record the finest detail. Follow this with a thicker mixture. But if the first mixture is too thin, it may wash away details. Testing will show the right proportions.

A thin mixture records more detail than a thick mixture. But it also needs a longer time to set. The mixture will set faster if salt is added to the water. One-half teaspoon of salt should be added to each pint of water. The more salt, the faster the setting. Sugar added to the water will slow the setting. One part of borax to ten parts of water will slow the setting from 15 to 30 minutes. It also makes the cast harder and clearer. These substances should be added to the water before the plaster or dental compound is added.

Two ways to prepare the mixture may be used. Both ways require you to sift the powder into water. Never add the water to the powder. One way is to sift the powder slowly into the water while stirring. The second way

is to sift the powder around the edges of a water-filled container. Powder is added until it begins to rise to the surface. When cracks appear, no more powder should be added. Mix by stirring under the top to a thick, creamy consistency. Remove any lumps.

Pour the mixture into the print. Pour it from a low level. Break the force of the falling mixture by using a spatula or your hand. Pour the mixture into the print at a place where there is little detail.

After one-half to three-fourths inches of mixture has been poured, add reinforcing material. Sticks or wire are good to use. But care must be taken to keep the ends from sticking through the bottom of the cast. Soak twigs or wood in water before use. Dry twigs or wood will soak up water from the cast, making it fragile. Lay the twigs, sticks, or pieces of wire at random in the cast. Do not lay them parallel. If they are laid in only one direction, the cast may fracture between the pieces. Or you can use wire mesh to prevent this problem. After the reinforcement is put into the cast, more mixture can be added until the desired thickness of the cast is reached. When using dental stone, no reinforcing material is needed. And casts need be only one to two inches thick. Dental stone is three to four times as strong as plaster. The addition of reinforcing material could cause the stone to crack.

The mixture hardens about 25 minutes after preparation. While setting, it becomes warm. When it starts to cool, the cast is hard enough to remove for processing. Care must be taken in its removal. The cast is still fragile, even when it is reinforced. Allow the cast to dry 36 to 48 hours before sending it to the lab.

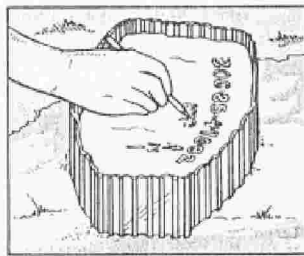
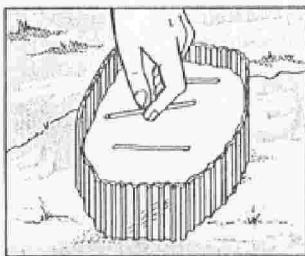
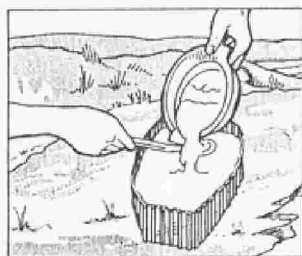

Pour plaster over a spatula; add reinforcement, followed by more plaster; then mark cast with ID and arrow pointing North.

### Casting Under Water

It may be necessary to cast a footprint or tire print that is under too much water to drain or to remove. A section of stovepipe may be used to direct the dry powder to the print. This prevents waste of the powder. The powder should be sifted into the print through the stovepipe. This can even be used in deep water. Salt may be added to the mixture to speed the setting time. Three to four parts salt to ten to twelve parts dry mixture is a good mix.

### Casting in Snow

Because dental stone, plaster of paris, and dental compound give off heat as they harden, their mixtures, when casting in snow, have a tendency to melt the snow. This can destroy the print or damage the print's details. Thus the temperature, depth, sticking quality of the snow, and the condition of the ground surface must be carefully considered. You should make test casts in the snow away from the print. This will help you decide how to proceed.

The print may be strengthened with plastic spray. Then, a thin layer of talcum powder can be put in the print with a syringe. The talcum acts as insulation against the heat. The print should be sprayed again. Several coats of spray may be necessary to fix the print. Use a retaining wall to keep the mixture from spreading to areas which are not insulated.

### CASTING WITH SILICONE

Silicone can be used for foot and tire prints, dust prints, tool marks, casting of parts of the human body, and fingerprints. Silicone

## CASTING DIFFICULT IMPRESSIONS

Some impressions present special problems for casting. Tool marks can be changed or destroyed in attempting to make casts of them. And tire imprints require more extensive casts than other imprints.

### TOOL MARKS

Avoid making casts of tool marks when possible. Original tool mark evidence is more useful for scientific examination. It is less subject to attack in court than casts. And

rubber is not recommended for surfaces with natural patterns like leather or fabric. The detail of the print is hidden by the detail of the natural surface.

Silicone rubber is a fast setting rubber. It sets up in a firm rubbery mass. The catalyst that causes it to set comes in a small tube with the package. The catalyst should be totally mixed with the liquid rubber just before using. Stir and pour the mix smoothly to avoid air bubbles that may cover details in the cast.

Setting time of the rubber can be changed by adding more or less catalyst. About one-half teaspoon of catalyst to a pound of the rubber is usually needed. Instructions are sent with the material. When catalyzed, the rubber will remain workable for about 5 minutes at 77° Fahrenheit. Lower temperatures lengthen setting time. A setting time of 5 to 10 minutes for prints in dust is recommended.

### CASTING WITH LIQUID SULPHUR

When casting with liquid sulphur, add one part iron filings to eight parts melted sulphur. Let the mixture cool. When you use liquid sulphur, the retaining wall must have a light coat of oil. The object bearing the impression should be lightly oiled, too. While the sulphur is still liquid, pour it over the object to be cast. The sulphur can be blown into the smallest of indentations.

Sulphur is useful for casting in snow. You can take it to the scene in a thermos bottle. The liquid sulphur crystallizes on contact and gives excellent detail.

often you are not able to make casts or photographs that show enough evidence. This makes identification hard at the lab.

When you must make a cast of a tool mark, use the material best suited for the shape and type of mark to be reproduced. Flat tool marks like hammer, chisel, and pry marks may be reproduced with a variety of materials. Tool marks in wood, where undercuts are present, will have to be reproduced with a flexible material.



Do not try casting or molding a tool mark until you have practiced on a similar wooden or metallic surface of no value. Take enough care and time to get a usable reproduction. Keep the surface bearing the tool mark as original evidence until you have an accurate reproduction. Then clear its release with proper legal authorities.

An imprint found on wood or on a metallic surface may be cast with modeling clay or plasticine. These materials do not take any special preparation before use. They are not likely to damage a tool mark if the first casting try does not work. A reproduction of the tool mark itself may be made from this cast using plaster or dental stone or compound. Usually, you need not reproduce a mark on a wood surface because the original evidence can be easily removed and retained.

### TIRE IMPRESSIONS

Casts should be made of the entire circumference of the tire involved. The circumference of a tire is usually between 5 and 8 feet. The likelihood of matching a track with a certain tire increases with the length of the cast made.

Casts should be made of each track found. Testimony that the combination of the designs taken from a set of four tire impressions found at the crime scene corresponds to the designs and the wheel positions of the four tires on the suspect's automobile is of obvious value.

Suspect tires should be sent to the lab with the casts. Leave the rims on the tires and keep them inflated. The lab may need to make test prints with the tires. Each cast and tire sent should be identified as to the wheel position. Sketches, photographs, and other notes should also identify wheel position.

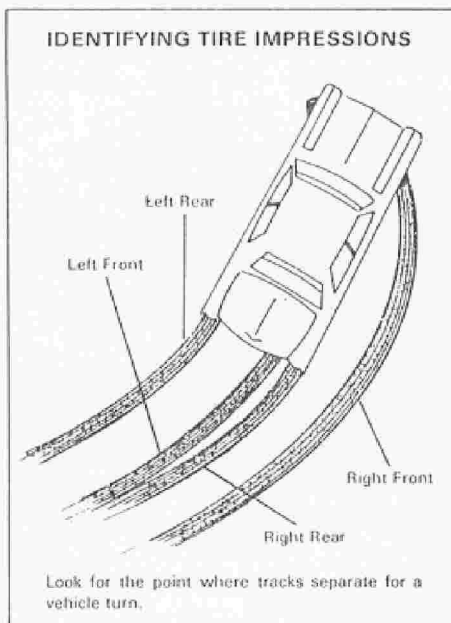

### COMPLETING THE CAST

Whatever your material, after you have made the cast and before it is set, you must mark it for identification. The data can be scratched into the surface of the cast. Any instrument may be used. The minimum data should be the case number, date, and your initials. An arrow showing north will help locate the exact placement of the cast in relation to other evidence.

Sometimes several casts are made at the same location. These casts should be numbered consecutively. The number and place of each cast should be entered in your notebook. You may want to take casts of several shoe and tire prints found at the

scene. This can help the lab specialists with their examinations. One print made by a shoe can give details not found in a second print made by the same shoe.

After you have removed the cast from the print you may gently remove excess dirt by hand. Do not use a brush or water under pressure. It may damage details. If you collect parts of the soil in the area near the print for testing with soil on the shoes or clothing of a suspect, do not wash the cast. The clinging soil will provide the lab with samples of the soil directly under the shoes of the suspect when he made his imprint. It may aid the examiners in comparing the soils.

## PACKAGING

Casts must be carefully packaged to send to the lab. A cast is fragile evidence. It is easily abraded. It must be handled carefully. The cast should be wrapped in soft paper or cotton. This may keep fine identification points from being destroyed. It should then be wrapped in strong wrapping paper and

placed in a box. Cushion the cast on all sides with shock absorbing material. Wax and modeling clay casts are not as fragile as other casts. But they can be deformed by pressure. These casts must be protected from pressure as well as abrasive action.

## MOLDING

Sometimes you may need copies of a cast. Having a cast can help in your search for the item that made the original print. To obtain copies of a cast you make a mold from the original cast. Once a mold is made of the cast, as many copies as needed can be made.

The way you make a mold is almost the same way you make a cast. Pour your mixture into a container. A rubber photochemical

tray makes a good container. Give the cast a thin coat of light oil. Without the oil it may be impossible to remove the mold from the cast. Place the cast in the molding mixture. When the mixture is set, remove the cast. This leaves a mold that may be used for making other casts. The inside of the mold must be coated with oil before each duplicate cast is made.

## Firearms and Ammunition

Solving a crime that involves firearms often depends on the scientific examination of evidence by a qualified examiner at the criminal investigation laboratory. Laboratory examination may show that a projectile or an expended cartridge case was fired from or in a specific weapon. Testing the mechanical condition of a weapon may show that an accidental discharge was possible. Other tests may show the presence or absence of gunpowder residues in the barrel of a weapon. A fired bullet or cartridge case may show the caliber and type of weapon that fired it. It may also tell the manufacturer of the ammunition. Tests may show the distance between the muzzle of the weapon and the point of contact. They may also show the point of entrance and/or exit of a projectile in clothing, wood, glass or metal.

### CONTENTS

	Page
RECOVERING AND PRESERVING EVIDENCE .....	87
MARKING EVIDENCE .....	87
TRANSMITTING EVIDENCE .....	89
TESTING AT THE LAB .....	90
Test Firing .....	91
Gunshot Residue Analysis .....	91

Investigators do not perform firearms identification tests in the field. The USACIL firearms examiners do the identification tests at the lab, and give test results to the investigator in the field. They also give expert testimony in court when needed. But while expert testimony may be given only by such a qualified lab examiner, the solving of a crime involving firearms may depend on how you, the investigator, collect and preserve firearm evidence.

### RECOVERING AND PRESERVING EVIDENCE

Any item that may need the services of a firearms examiner must be handled with care to make sure it is not altered or damaged. For instance, you must try to have medical personnel cut around bullet holes to leave them intact when removing clothing from shooting victims. And you must also make sure the items do not become contaminated. Be especially careful when clothing and like items are involved. Air dry bloodstained and semen-stained clothes before packaging.

You may find it hard to recover fired bullets at a crime scene. Never probe for, or try to extract, a bullet with other than rubber or heavily taped tools. It is often best to take a small section of the wall, ceiling, or the like

with the bullet still in it. By forwarding it intact to the laboratory you prevent damage to the bullet.

You may have a case where you feel that a weapon should be processed for latent prints. The parts of weapons having a slight oily film are not ideal for the development of latent impressions. However, it is possible to get usable impressions. Firearms evidence to be sent to the lab to learn when the weapon was last fired or for powder residue should not be processed for prints before the lab examines it. Latent print techniques may hinder the examinations of the firearms examiner. At the lab, the fingerprint and firearms examiners will coordinate their efforts.

### MARKING EVIDENCE

Evidence must be marked so it may be readily identified later. Firearms known to be of evidence value are marked immediately. But those seized or impounded to decide their value are not to be marked, scratched, or

defaced in any way. These items are marked only after it is decided that the firearm has value as evidence. Use common sense in marking antique weapons and highly engraved weapons: Protect their value.

Place your initials and the time and date of recovery on each item of evidence so you can positively identify it at a later date. When several like items are found, add an identifying number on each item. No two items of evidence in the same case should bear the same identifying numbers. All identifying marks and a description of items to which they are affixed should be put in your notes. The identifying number has no bearing on the numbers of the exhibits in the report of investigation.

Marking tools may be used for inscribing identifying markings on firearms evidence. Diamond point or carborundum pencils are ideal. Dental picks make excellent marking devices when the curved tip is cut off and the point made needle-sharp. These can be obtained at dental clinics and dentist's offices from time to time.

Firearms are most often marked on the right side of the frame. Mark all parts of the firearm that can be removed and that leave imprints on either the bullet or cartridge case.

For example, you would mark a conventional .45 caliber semiautomatic pistol in three places. You would mark the barrel, which marks the bullet; the slide, which contains the extractor and firing pin; and the receiver, which includes the ejector which marks the cartridge case. All parts of a weapon should be marked alike. Put your mark where the marking can be seen but will not interfere with existing markings or stampings on the weapon. Mark the magazine on the base toe and submit it with the suspect weapon.

Because some revolvers have interchangeable cylinders, revolvers are marked on both cylinder and barrel. Some revolvers have a removable side plate. Mark them on the side of the frame that cannot be removed. Mark weapons having removable bolts—semiautomatic and automatic weapons, as well as bolt-action weapons—on the bolt, barrel, and frame. If the barrel of a weapon cannot be removed without tools, you do not need to mark it. But marking the barrel, even under these circumstances, adds certainty.

#### INVESTIGATOR'S MARKINGS ON FIREARMS EVIDENCE

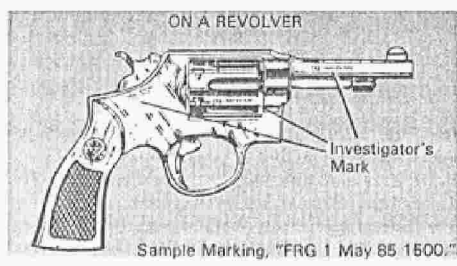

A fired bullet submitted as an exhibit may be jacketed or lead. Do not place any markings on the bullet. Identification marks may cause the loss of trace evidence or evidence marks. Rinse the bullet if it is not to undergo serology testing or examination for other trace evidence. Ridding the bullet of body fluids or other contaminants will help the firearms examiner. Rinse with care, making sure you do not rub the item. Place bullets in suitable containers. Pillboxes, plastic vials, and the like that have cotton packing material are fine. Seal the container with paper packaging tape or the equivalent; do not use cellophane or masking tape. Mark

the container so markings are on both tape and package. Record the time and date of sealing, your initials or signature, and the USACIDC sequence number or MP report number. Deformed bullets and jacket fragments must also be placed in a container and marked as described above.

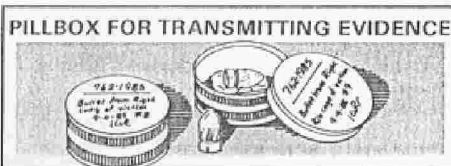

Do not mark cartridge cases. Treat them the same way you treat bullets, then place them in a container. Do not mark shotgun shell cases, wads, or shot columns either.

Shot pellets (birdshot, buckshot, other) known to be from one source can be placed together in a container. Seal container and mark it for identification.

## TRANSMITTING EVIDENCE

Unload firearms to be examined at the USACIL before preparing them for shipment. If a firearm cannot be unloaded, contact the USACIL for advice and shipping instructions. Firearms may be shipped by US mail as allowed by postal laws and regulations. Live ammunition, propellant powders, primers, or explosives may not be sent through US civil or military mails. Such items are shipped by freight or transported by courier.

Wrap firearms in a clean protective covering. This prevents dust, lint, and other foreign matter from filtering into the mechanism. Pack in suitable shipping containers. When the evidence is to be examined for fingerprints, use special packaging procedures. If you have a question about how to pack or ship evidence, contact the USACIL.

Do not clean firearms before shipping them to the lab. But if there is a lot of moisture in the weapon barrel, remove as much of it as you can to stop rust from forming. Use a single dry patch. Record this fact in your notes and on the lab request. A collection of rust makes it hard for the lab examiner to

conduct a comparison test. In a special case, when firearms must be cleaned, consult the USACIL. And be sure to send the cleaning patch to the lab when you send the weapon.

All ammunition found in the possession of a suspect or at the scene of a crime is seized and held as evidence. The laboratory may have enough ammunition of a like type to use for test needs. Contact the lab firearms division to learn if they have the right ammunition. If not, arrange for ammunition picked as evidence to be sent to the lab with the weapon.

When revolvers having loaded cartridges or fired cases are obtained, make a diagram of the rear face of each cylinder. Show the position of the loaded cartridges or the fired cases with respect to one another and to the firing pin. Scratch an arrow on each side or rear face of the cylinder lying under the firing pin when the revolver was found. Do this on the revolver, itself, and also on the diagram. Your diagram, complete with legend, lets the lab examiner relate the fired cartridges to the chamber of the cylinder in which they were fired.

### NOTATION OF THE POSITION OF THE CARTRIDGES IN A RECOVERED REVOLVER

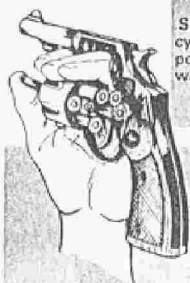

**FACING REAR  
OF CYLINDER**

Scratch arrow on rear face of cylinder to show the chamber positioned under the hammer when weapon was recovered.

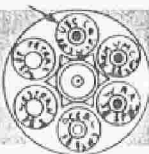

Draw diagram, label chamber under the hammer "1"; number remaining chambers clockwise.

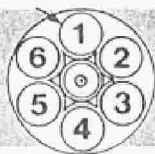

Investigator's Mark	Chamber Position	Condition	Maker
CW/1	#1	Fired	U.S. Cartridge Co.
CW/2	#2	Fired	Remington Arms Co.
CW/3	#3	Fired	Winchester Repeating Arms Co.
CW/4	#4	Misfire	Dominion Cartridge Co.
CW/5	#5	Loaded	Western Cartridge Co.
CW/6	#6	Loaded	Peters Cartridge Co.

Pack clothing items being sent to the firearms division for proximity tests so the area around the entrance hole in the garment does not become contaminated. Do this by

sandwiching between sheets of cardboard or brown paper the part of the garment containing the gunshot residues.

### TESTING AT THE LAB

Testing by lab examiners can provide you with information you are not able to determine by field examination. For instance, in gunshot wounds, powder residues may be deposited either on skin or clothing. Only pathologists or other qualified medical persons may give an expert opinion on gunshot wounds in flesh and on their powder pattern. And only lab examiners can give you an expert opinion on powder residue in clothing. By firing a suspect weapon, using ammunition of the type that left the residue, they can make tests to learn the approximate distance from muzzle to point of contact. These proximity tests are based on the dispersion of the gunpowder residues. They are, of course, subject to limitations. A scaled photo of the wound may be helpful to a firearms examiner examining the clothing worn by the victim. Normally, with a muzzle

to target distance in excess of 2 1/2 feet, no discernible gunpowder residue pattern will be present. But particles may be present even at a distance beyond 8 feet.

Sometimes a firearm has had a serial number or other die-stamped lettering removed. Showing ownership or otherwise identifying the item may depend on discerning the serial number. *This is a job for the lab. Do not try to do it on your own.*

Often the lab can examine a fired bullet or even a cartridge case alone to learn facts of the class characteristics of the firearm involved. The lab can tell you the caliber and type of firearm (pistol, revolver, rifle) from which the bullet was fired. The number and width of lands and grooves in the rifling and the direction of twist may also be provided.

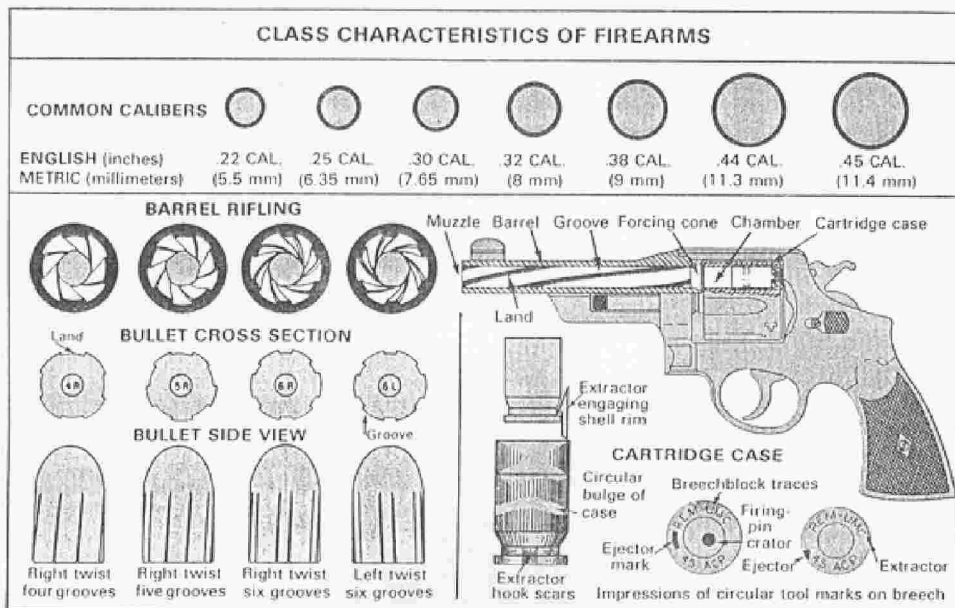

### TEST FIRING

If a firearm is sent to the lab with fired bullets, cartridge cases, or both, tests can be done to see if the ammunition was fired from that weapon. If the class characteristics of the spent ammunition is consistent with that fired from a weapon like the exhibit weapon, test firing will be done. Then the test bullets and cartridge cases will be microscopically compared with the exhibit items. If many firearms are suspect weapons in a case, it may not be wise to ship all the weapons. In such cases, contact the supporting lab for advice.

All firearms uncovered during the investigation of homicides, suicides, assaults, and robberies should be submitted for function testing. Often the value of learning if a firearm will function and if it functions safely is overlooked. It may be that a firearm could not have discharged accidentally as stated by a suspect. Or a particular firearm may not be capable of firing at all.

### GUNSHOT RESIDUE ANALYSIS

There are two types of gunshot residue tests done at the lab. One, discussed earlier in this chapter, is done to search for and identify

unburnt powder particles and measure muzzle-to-target distances using the residue patterns left on the target. The other is done to detect primer residue to tell if a subject has handled or fired a weapon. This is from the test commonly known as the "gunshot residue test." Examiners at Trace Branch, USACIL-Continental United States (CONUS), do all of USACIDC's gunshot primer residue tests.

The primer residue test checks for antimony and barium, two metallic elements often found in primer mixtures. The primer mixture, detonated by the firing pin, is what ignites the gunpowder in the cartridge. The nature of this residue is such that, at present, only swabbings are tested. Gloves or other articles of clothing that the subject may have been wearing are not checked. Primer mixtures are manufactured by only a few companies. They cannot be related to a specific brand or type of ammunition. The lab cannot tell from the residue test what brand of ammunition was used. Likewise, the test does not show which weapon was used by a subject or which was used to fire certain ammunition.

### GUNSHOT RESIDUE PATTERN ANALYSIS

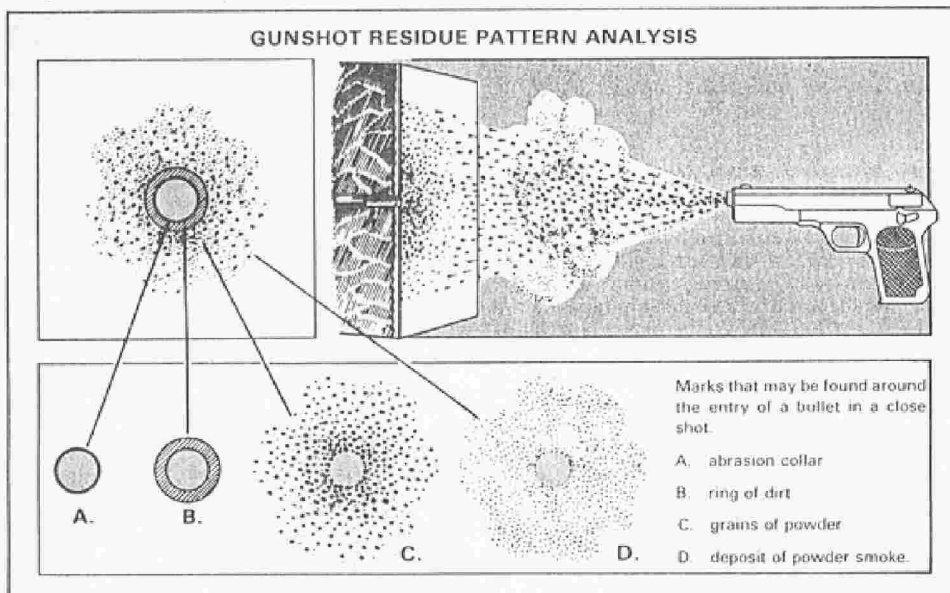



The primer residue collection kits issued by USACIDC have all of the items needed to swab the subject's hands. They give the proper analytical controls as well. The process picks up the residue for protection in

a vial. In this way the samples can be sent safely to the lab. Presently, there are two brands of kits. They differ only slightly, and either is suitable. Each kit has a set of instructions.

#### PRIMER RESIDUE COLLECTION

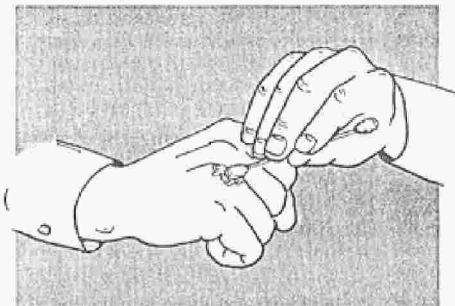
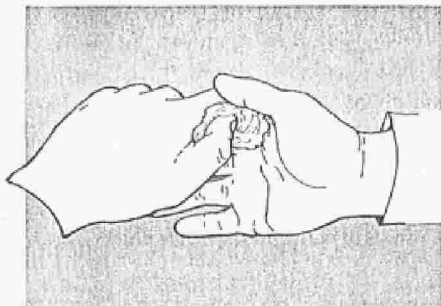

A check for primer residue can be made by swabbing a suspect's hands and sending the collected material to the lab for analysis.

## CHAPTER 15

**Burglary, Housebreaking, and Unlawful Entry**

**Burglary, housebreaking, and unlawful entry are offenses that all involve entry onto or into property without permission or authorization.** But the offenses differ in method of entry, time of entry, type of structure entered, and the intent of the intruder making the entry.

Burglary is a crime of stealth. It takes place under the cover of darkness. It is most often combined with theft, but it may involve more violent crimes like murder, rape, or arson. Persons subject to the UCMJ who, with intent to commit an offense punishable under Articles 118 through 128, (except Article 123a, bad checks), break and enter in the night time the dwelling houses of another, are guilty of burglary.

The break-in may be by physical force or by trickery like that of pretending to be a telephone inspector. Entering through a hole in a wall or an open door is not a "breaking" under the law. But if a partly open door or window is opened wider to permit entry, it is a breaking. And, of course, entering by removing or opening any part of a dwelling, like a screen, a window pane, or a door meets the requirement of breaking.

As soon as any part of the body is inserted into the dwelling, the requirement of "entry" is met. Inserting an object, like a pole, into the dwelling to extract property also qualifies as entry. The breaking and entering must be done to a dwelling belonging to another. This includes outhouses within a cluster of buildings used as a residence. It also includes separate dwellings within the same apartment or building.

The breaking and entering must occur between sunset and sunrise when there is not enough light to discern a person's face. And it must be done with the intent to commit an act of murder, manslaughter, rape, sodomy, carnal knowledge, larceny, wrongful

## CONTENTS

	Page
RESPONDING TO THE SCENE.....	162
RECONSTRUCTING THE OFFENSE .....	163

appropriation, robbery, forgery, arson, extortion, maiming, or assault. The offense does not have to be committed or even attempted. It is the *intent* to commit the act that is the basis of the proof of burglary.

Housebreaking is like burglary in that the intruder enters a structure unlawfully with the intent to commit a criminal offense within the structure. But the offense which the housebreaker intends to commit need not be covered under Articles 118 through 128, UCMJ. It need only be the intent to commit some criminal offense. Any act or omission punishable by a court-martial, except one that is a purely military offense, is a criminal offense. And the accused's intent must be alleged and proved to support a conviction of this offense. Housebreaking differs from burglary in that the place entered does not have to be a dwelling. Nor is it required that the place be occupied or that there be a breaking. And entry may occur in daylight as well as in darkness.

Unlawful entry upon lands or structures without force but by means of fraud or other willful wrong is closely related to housebreaking. But unlike housebreaking, the intent to commit an offense within the place entered is not needed for this offense. The basis of proof for this offense is that the entry was unlawful and that the conduct of the accused was prejudicial to good order and discipline.

When investigating a burglary or housebreaking you must be ready to cope with any of several other crimes. Most often, you are faced with a crime of theft or larceny. Thus the investigative techniques for larceny often apply to burglary. Your goal will be to identify and apprehend the offenders and recover as much stolen property as you can.

## RESPONDING TO THE SCENE

When you arrive at the scene, note and record the location and description of the structure or area entered. Find out where the owners or occupants were at the time of the crime. Learn when the owners or occupants left and if all the doors and windows were secured. Try to learn the time the offender entered the structure or area. Try to learn the number of persons thought to have approached the crime scene.

Seek evidence as to how the offender arrived at the crime scene. Footprints or tire tracks may show the route or means of entrance to the place of the real property.

Study the tire tracks to learn the type and number of vehicles, the direction of travel, and the places parked. Look for materials that may have been dropped, like gas, mud, oil, or water. Check also for those that might have been picked up, like soil or rock. Make casts of tire tracks and footprints found at the crime scene and send them to the lab. Once a suspect vehicle has been found, you can send the tires to the crime lab to be compared with the casts made at the scene.

To learn where and how the entry was made, search the property for broken or unlocked doors, windows, skylights, or gates.

## ASSEMBLY CHARACTERISTICS OF HOUSEHOLD LOCKS

## PADLOCK

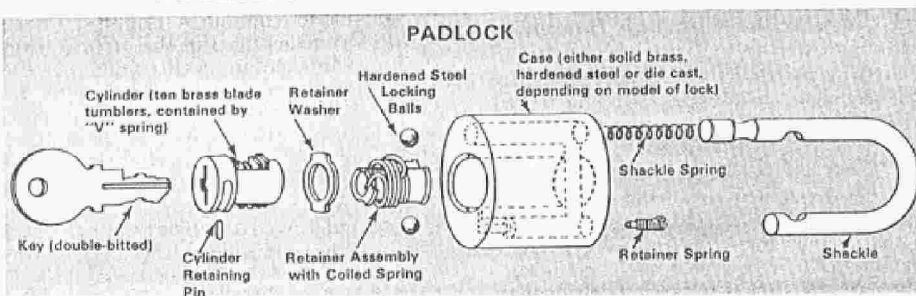

## DEAD BOLT

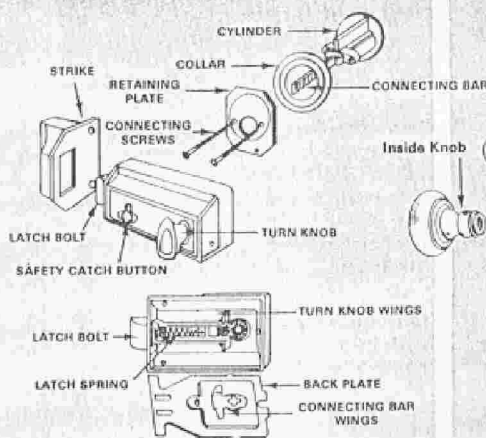

## ENTRANCE-DOOR LOCK

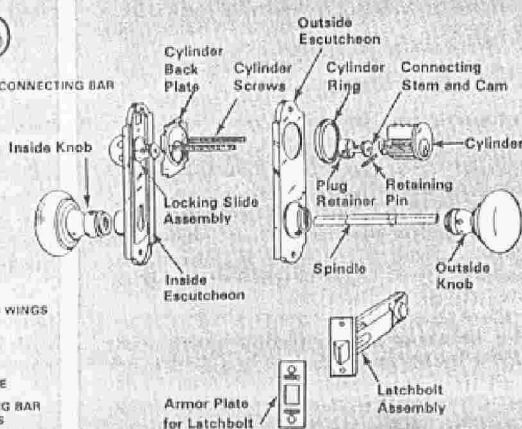

See if locks or fasteners were forced. Check for holes sawed or hacked through walls, floors, partitions, or roofs. Lab examination of wood, glass, or metal evidence found at the scene may show the direction of the breaking force. You may also learn the kind of instrument used.

Check the size and shape of openings. See if they are large enough for an offender to get in and large enough to permit removal of the stolen property. Note the height of the openings from the ground or from where the offender stood. Try to tell if entry was made bodily or by reaching through a window with an arm or an instrument. See if it seems likely someone inside the building could or must have helped in the crime by passing items to the offender. How much help would be needed

to remove the stolen items? How many persons would it take to handle the equipment?

Try to tell what equipment, such as ropes, ladders, or digging tools, were used in the breaking and entering. Collect toolmarks that show a forced entry in original form if you can. If you must remove a door or cut away part of a building, post a guard for security until repairs are made. When you cannot collect original toolmarks, make casts or molds of them. Toolmarks should be photographed and measured and the area dusted for prints before casting a mold or removing a damaged section. Tire tracks and footprints, too, should be photographed before casts are made.

Look carefully to see if any evidence was destroyed. Offenders often wipe off fingerprints, wear gloves, deface toolmarks, or try to obscure footprints and tire tracks. Try to tell if evidence was damaged by the offender, the victim, or the witnesses before MP arrived. Note what was damaged by accident and what was damaged on purpose. If the area contains records, check to see if they are in order. The offender may have tried to falsify, destroy, or misplace them.

Detecting the method and route of exit and flight may give leads to the offender. Learn if the offender used an existing escape route or broke out. Consider if more than one trip was made to remove stolen items.

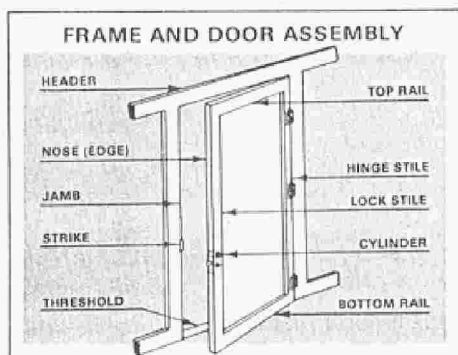

## RECONSTRUCTING THE OFFENSE

Often you can simulate an offender's search of the scene. This simulation may show if the offender was familiar with the place. And note the manner of his search. It may be a feature of a familiar MO.

Look for fingerprints and other evidence at points where the offender searched. This may reveal important information. A careful study may suggest how much time the offender spent on the premises. You may learn how skilled the person is or how secure he felt. If it appears that the offender went directly to the stolen object, it could suggest he had advance information. How did he get such information? Was the offender's search systematic, thorough, selective, or

haphazard? The manner of search may show it to be the work of a professional or an amateur. Were objects replaced after being examined? Did the offender close doors and drawers? Such actions may show a choice of articles and motive. They may also hint at the offender's presence of mind and consciousness of detection. Consider what the offender did to deter detection while searching the scene. Were shades or blinds drawn? Was the inside door locked? Check for evidence of planned alternate escape routes.

It is possible that the victim is actually the offender. Sometimes crimes are staged to try to collect insurance or make a claim against

the government. Consider if another offense, like arson, was committed to hide the original crime. And keep in mind that the crime scene

or evidence may have been deliberately arranged to mislead or to draw suspicion from the offender.

#### INFORMATION USEFUL FOR INVESTIGATING A BURGLARY OR A HOUSEBREAKING

- Is the entered structure a residence, store, office building, warehouse, garage, or other type of structure?
- Where were the owners or occupants at the time of the crime?
- When did they leave? Were all doors and windows secured?
- Where were the keys? Did other burglaries and housebreakings occur in the same area? Was the same modus operandi used?
- Have there been any recent visitors to the premises? What about tradesmen and utilities inspectors?
- Was the crime committed by someone inside or outside the premises? Were the premises occupied at the time? Was entry gained by force? If an outside job, how did the criminal enter?
- Was entry effected by picking a lock, by taking wax impressions, or by using skeleton keys or other burglar tools?
- Does the completed list of property that was stolen include a detailed description with identifying data?
- Where, when, and how was any property recovered? Did the owner identify it?
- Did the thief limit himself to one kind of property, or take other valuable items?
- Did the criminal conduct a systematic search? Did the search indicate a knowledge of the area? Were alarm wires cut?
- Have pawnshops and secondhand shops been checked for loot? Have express offices been checked for evidence of recent shipments?
- Did the thief do anything besides search and steal? Did he eat, did he smoke, did he commit a nuisance? Were any cigarette butts or matches found? What brand were they?
- Were any tools recovered at the scene? Were any tools recovered from the person of the suspect or his dwelling?
- Has any person been seen loitering about the premises? Did anyone observe the criminal leaving the premises? Were any clues observed in or around the premises?

## CHAPTER 19

**Death**

When a person subject to or within an area of military jurisdiction dies, an investigation is made to learn if a criminal act contributed to the death. Only when a person dies from natural causes while under medical attention is this not done.

You may be called on to assess the facts of violent deaths. It is important that

these deaths be looked into properly. To tell if a death is homicide, suicide, or accident requires skill, training, and experience on your part, and the technical expertise of examiners at a crime lab. Criminal blame, if present, must not be overlooked. But if the death was accidental, unjust criminal charges must not be brought against innocent persons.

**RESPONSIBILITIES AND COORDINATION**

Many agencies are responsible to the commander for investigating suspicious deaths. Close liaison must be made within commands between investigative, medical, and related forensic personnel for effective death investigations. Matters of mutual

interest include jurisdiction; investigative responsibilities; local agreements with the civil authorities; status of forces agreements; and rules to be followed by MP, USACIDC, medical personnel, and pathologists.

**CONTENTS**

	Page		Page
<b>RESPONSIBILITIES AND COORDINATION</b> .....	185	<b>DEATHS INVOLVING ASPHYXIATION</b> ....	199
<b>MEDICOLEGAL AUTOPSY AND POST MORTEM CONDITIONS</b> .....	186	Stranglings .....	199
Low Body Temperature .....	187	Hangings .....	199
Livor Mortis .....	187	Drownings .....	201
Contusions .....	188	Electrical Shocks .....	202
Bleeding .....	188	<b>DEATHS INVOLVING SHARP-EDGED INSTRUMENTS</b> .....	202
Rigor Mortis .....	188	Stabbings .....	202
Putrefaction .....	188	Cuttings .....	204
Adipocere .....	189	Choppings .....	205
Mummification .....	189	<b>DEATHS INVOLVING BLUNT FORCE</b> ....	205
Consumption by Insects and Animals ..	189	Beatings .....	208
<b>INVESTIGATIVE ACTIONS</b> .....	190	Explosions .....	208
Initiating the Investigation .....	190	Falls .....	208
Checking for Wounds and Estimating Time of Death .....	190	Crushings .....	208
Reconstructing the Scene .....	191	<b>DEATHS INVOLVING FIRE</b> .....	208
Identifying the Deceased .....	192	<b>DEATHS INVOLVING SEXUAL ASSAULT</b> ..	209
Checking Motive and Opportunity .....	192	<b>DEATHS INVOLVING TOXIC SUBSTANCES</b> .....	209
<b>DEATHS INVOLVING FIREARMS</b> .....	192	Poisonings .....	209
Bullet Wounds .....	193	Overdosings .....	211
Entrance Wounds .....	193	<b>DEATHS INVOLVING INFANTS AND CHILDREN</b> .....	213
Exit Wounds .....	196	Infanticide .....	214
Shotgun Pellet Wounds .....	196	Battered Child Syndrome .....	214
Shootings .....	197		

The provost marshal office and USACIDC are responsible for obtaining all facts pertinent to deaths occurring under suspect conditions. As an investigator you must determine the manner of death to be a homicide, a suicide, or an accidental or natural death. If the deaths were accidental or homicidal, you will investigate to identify the persons responsible.

The medical officer, often a specialist in pathology, determines the medical cause of death. You must cooperate fully with medical personnel and pathologists. They will work with you to learn the identity of the deceased and the approximate time and manner of death. They may depend on you to help them determine the cause of death.

You are encouraged to set up a liaison with the pathologist who does the autopsy. You must tell the pathologist of the known facts of death and initial investigative findings prior to the autopsy. This enables the pathologist not only to select proper ways to determine the cause of death but also to give an opinion about the manner of death. The medical officer must also complete certain military records and official certificates of death. You work with the medical officer to collect and preserve evidence. This includes obtaining at least two sets of major case prints from a

deceased to compare with latent prints found at the death scene. You will also direct photography.

The line of duty (LOD) investigating officer determines the duty status and personal conduct of the deceased. The LOD officer has no jurisdiction with the criminal investigation. The safety officer determines the safety factors or lack of them in an accident. His or her interest in accidents is limited to safety.

Close intelligence liaison is needed and directed by AR 195-2. A report of death due to homicide, accident, or suicide must be relayed at once to the nearest intelligence agency. If the victim had access to classified material, ask the intelligence officer to find out if any of this material is missing. The intelligence officer is responsible for security measures. His or her main concern is to insure that classified material is not compromised. This is very important if the death is a suicide. Ensure that intelligence officials are kept fully advised until no further security interest exists.

In some instances, the post commander or higher authority may call a board of inquiry to find out the facts connected with a death. Such a board has broad powers and may check into all areas of the matter.

## MEDICOLEGAL AUTOPSY AND POST MORTEM CONDITIONS

A medicolegal autopsy is authorized or ordered by authorities in all cases when a death is unattended. Generally, autopsies on persons who were subject to the UCMJ are done by military pathologists. Other autopsies are done by civilian pathologists on request or order of civil authorities. Procedures may differ overseas in areas over which US commanders have authority.

In a medicolegal autopsy special emphasis is placed on identifying the victim by photograph, fingerprint, dental and medical records, and/or next of kin. Final assessment of the cause and manner of death is made only after a complete medicolegal investigation reviews autopsy and toxicologic tests.

During the autopsy, you and the pathologist exchange facts and views to learn the circumstances and mechanism of death. You discuss with the pathologist all known facts, considerations, and information. You should be present at the autopsy to answer questions and to receive evidence or specimens taken from the victim. If the pathologist's findings are not understandable or if they seem to conflict with known facts, discuss them with the pathologist before he releases the body from medical control. An early and important concern that you and the pathologist consider when checking the location and character of wounds is whether or not the victim could possibly have caused the wounds to himself.



### INFORMATION AN AUTOPSY MAY PROVIDE

- Estimated time of death.
- Type of blood.
- Cause of death and determination of which wound was fatal.
- Type of weapon or substance used and manner of use.
- Time interval between receiving wounds and death and if the victim was able to move.
- Drug and/or alcoholic content in the blood.
- Evidence of sexual assault, pregnancy, venereal disease.
- Opinions as to manner of death.

Take precise measurements of the body, site, number, shape, edges, and extremities of wounds. X-ray the wounds for trace evidence (metallic fragments). Also look for defense wounds. Determine the depth and direction of each wound. But remember, *never place an object in the wound*. Check all wounds carefully and collect trace evidence like glass, hair, and fibers. You may be able to tell which wounds were fatal. Collect samples for toxicologic tests. Note medical and other artifacts like embalmer's wounds or prosecutor's slips of the knife. Document all inner and outer scars. Check all wounds for multiple thrusts. Document your findings with photographs, drawings, and charts.

The presence of postmortem conditions in the body, as they were found and noted by you at the crime scene, are important to the pathologist as well as to you. You must be sure to mention them to the person doing the autopsy. Post mortem conditions to be looked for include low body temperature, livor

mortis, contusions, bleeding, and rigor mortis. They also include the conditions of putrefaction, adipocere, mummification and consumption by insects and animals.

### LOW BODY TEMPERATURE

After the vital functions of the body have ceased, body temperature adjusts to environmental temperature. It may be possible to learn the approximate time of death by the rate of heat loss and the temperature of the area where the body is found. When body temperature falls, the amount of heat loss depends on factors which can slow or speed the loss of heat. Age, size, weight, clothing, and environment all affect heat loss. At a temperature of 70° Fahrenheit, the average body temperature drops 1.5 degrees per hour for the first 12 hours.

### LIVOR MORTIS

After death blood settles toward the lowest part of the body. This causes a reddish-purple discoloration called livor mortis, or postmortem lividity. It is often seen within one-half to two hours after death. The hue of the livor mortis may give some sign of the cause of death. For example, a bright cherry-red hue may suggest carbon monoxide or cyanide poisoning. Inconsistent distribution of the livor mortis may suggest that the body has been disturbed. For four to six hours after death, slight pressure to the skin stops the flow of blood settling in nearby vessels. This results in blanching in that area. After the condition is set, moving a body no longer changes the distribution of it. If the distribution of livor mortis does not conform to the body's position, then the body may have been moved after the condition set.

### PATTERNS OF DISCOLORATION SEEN IN LIVOR MORTIS



The distribution of livor mortis is consistent with the pull of gravity. Blood settles toward the lowest parts of the body. If the body is seated at death, the reddish-purple discoloration may be expected to appear in the feet, lower legs, hands, and chin. If the body is lying flat, the discoloration is likely to be along a horizontal plane.



Areas of blanching appear within livor-darkened portions of the body where body weight and bone structure have compressed body tissue against an outside surface, closing blood vessels and keeping the blood from settling into the compressed area.



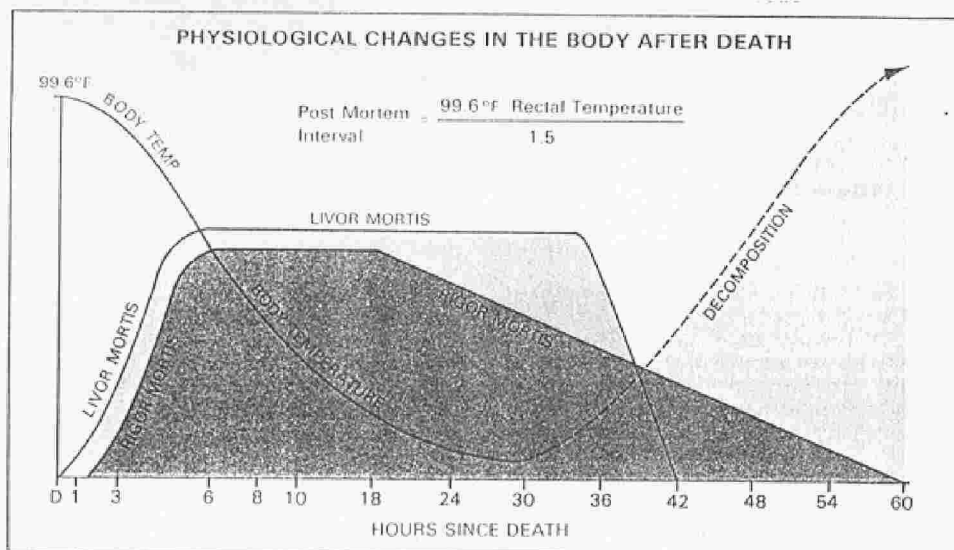

To record information about the livor mortis, take photographs and exact measurements before the body is moved. Note folds in clothes and positions of belt, buttons, jewelry. Look for anything which could have exerted pressure on the body.

### CONTUSIONS

A contusion, or bruise, is a localized hemorrhage within the body. Bruises are caused by blood spreading under the skin. They can result from a blunt impact or from fractures or torn soft tissue like ligaments and muscles. They also may be caused by indirect trauma like twisting or falling. A recent bruise is very dark red, reddish-purple, or blue. The color of it is uniform. In a day or so, a yellowish margin appears. Later it changes from green to brown and then to brownish black. You should photograph bruises with a color scale. Try to have a medical officer estimate the age of the contusion.

### BLEEDING

The presence and location of blood are important. When the heart stops, blood pressure drops to zero. Thus when injuries are seen, especially to the head, and there is no sign of blood or bleeding, the injuries may

have occurred after death. Sometimes wounds made after death on the underside of a body may show blood, but this is from blood draining down and out of the body from the influence of gravity. You should note the amount, color, degree of coagulation, size of area covered, and types of surface on which the blood rests.

### RIGOR MORTIS

Rigor mortis is a rigidity of the body caused by muscles contracting after death from chemical changes within muscle tissue. It starts in all muscles at the same time. But it is first noticed in the small muscles of the face, neck, lower jaw, hands, and feet. Its time of onset and completion depends on environmental conditions and the onset of decomposition. The rigor can be broken. For example, a leg may be straightened out, but it takes a lot of effort. If the rigor is broken after it has fully set, it will not return.

### PUTREFACTION

Putrefaction is a slow decomposition of the body. It is a chemical and bacterial change. It starts at death and continues until all soft tissue of the body is consumed. Temperature is important to the speed with which it

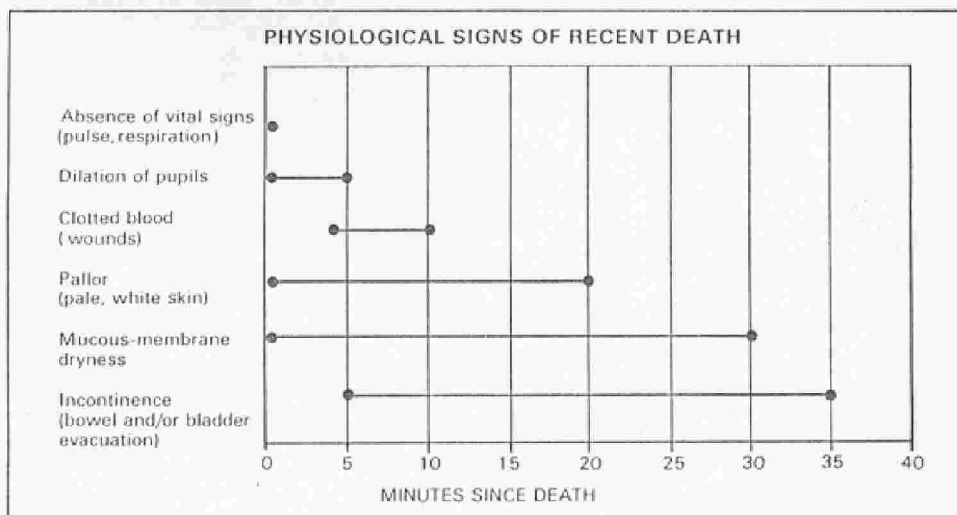

happens. Heat speeds bacterial growth and action, while cold slows it.

One of the first signs of putrefaction is a greenish staining in the lower abdomen. The change slowly spreads and takes on a brownish look. Sometimes the skin gets so dark, it may be hard to determine race. The condition called marbling comes from bacterial action on blood in the veins. They become dark red or purple and stand out lightly on the skin. And as bacteria acts on inner organs, gases form. They bloat the body, and facial features become vague. Putrefaction goes on until the body is consumed, unless adipocere or mummification begins.

### ADIPOCERE

Adipocere is a yellowish-white substance composed of fatty acids and soaps developed in post mortem changes of the fatty parts of the body like cheeks, abdomen wall, and buttocks. The chemical process is induced by enzymes and water in moist anaerobic conditions in which bacteria need no oxygen to survive. Adipocere has a greasy feel and a strong and musty odor. Although adipocere may cover wounds, the wounds can be seen in a close examination even when the process has advanced.

### MUMMIFICATION

Mummification occurs when body tissue dehydrates. The skin takes on a leathery look. The process only occurs in hot, dry climates, free from the moisture needed by bacteria. Mummification is more likely to occur in infancy than at later ages. The bodies of infants who die soon after birth are sterile. They do not have internal bacteria. Thus bacterial action is slowed because all bacteria must enter the body from outside. And, because of their size, the drying process can be completed faster in infants than in adults.

### CONSUMPTION BY INSECTS AND ANIMALS

Insects and animals may begin to consume a body soon after death. Flies, maggots, and beetles attack open areas of the body. They gather on soft body tissues. Sometimes an entomologist's study of insect larvae on a body can help estimate time of death.

Cats and dogs locked in a room with a body eventually will eat a human body. A body buried in a shallow grave often is dug up by animals for food. It is not unusual for bodies left in woods to have their parts scattered over a large area by animals.

## INVESTIGATIVE ACTIONS

The basic aim of a death investigation is to determine if the death was an accident, a suicide, or a homicide, and in the case of a homicide collect evidence leading to the conviction of the guilty party. The technique of investigating any violent death is basically the same. You investigate the circumstances, conditions, and events leading to and following the death. Learning and tracing the events and actions involving the victim before his or her death can show the likelihood of an accident or a clear intent for suicide or homicide.

Accidental deaths occur often under conditions which are suspect. Many of these deaths will look violent, but will lack criminal likelihood. Circumstances may show a logical reason for a weapon's presence and if there was a chance for an accident.

On the other hand, circumstances may strongly suggest death by suicide. Prior suicide attempts and earlier written or oral statements of intent, as well as suicide notes at the scene, are strong evidence of suicide.

Homicide, too, is often shown by conditions and events leading to and following the death. A disturbed scene, wounds to nonvital areas, punctured clothing, no weapon at the scene, no signs of suicidal intent or hazardous conditions, lack of hesitation wounds, signs of a fight, and signs of flight or surprise are all factors pointing to homicide.

The lack of a visible weapon at the scene most often suggests that the death was homicidal. But a suicide victim may live long enough to dispose of a weapon. Or he or she may arrange a contraption to cause the weapon to disappear after being fired. And relatives fearing social disgrace or having an interest in a suicide's life insurance may try to hide the deceased's suicidal intent and circumstances. Similarly, a murderer may try to make things look like a suicide or an accident. When distinguishing between suicide and homicide, it is very important that motive be learned. Opportunity is also a factor to be considered where there are signs that an apparent or alleged suicide may be a homicide.

### INITIATING THE INVESTIGATION

When you are notified of a death or an act of extreme violence, make every reasonable effort to get to the scene and secure it before it is disturbed.

If the victim is still at the scene and a doctor is not there, immediately check for signs of life. *Saving a life* takes precedence over all other actions. If the victim is alive, give first aid and have the proper medical authority notified. If the victim seems likely to die or is dying, try to get a statement. Make note of anything which may permit the statement to be admissible evidence as a *dying declaration*.

You must ensure that the scene is not contaminated. Curious onlookers can cause problems at a death scene. If the victim is still alive, onlookers can destroy evidence while attempting to help you. If the victim is dead they can destroy evidence by trying to cover the body. In either case they can deposit materials that may be mistaken as evidence. When you arrive on the scene have all unnecessary persons stand back from the immediate area.

Be sure the identities of all persons at the scene are verified. Learn the identity of the person who found the victim or who was first on the scene. Also identify the person who made the report. Process the crime scene with great care, using the steps you have learned for crime scene processing. Be sure to record the time you arrived. Also note the exact address, the temperature, and the weather. You will need this information for your investigation and for future legal proceedings. Without this information, your later testimony may be vague. This could cause the value of the rest of your testimony to be minimized.

### CHECKING FOR WOUNDS AND ESTIMATING TIME OF DEATH

You must check the body for external wounds or injuries. If a pathologist is with you, he can make a detailed description of the body site, direction, and measurements of the

injuries. It is desirable for a medical officer or pathologist to take part in the exam at the scene to note condition of the body, postmortem changes, environmental conditions and circumstances of death. Depending upon the conditions, a medical officer, especially a pathologist, can often give an opinion about the time of death. When certain control factors, such as climatic conditions and time of exposure to the elements, are known, a medical officer may give a broad estimate of the lapse of time since death. This is based on rigor mortis, livor mortis, loss of body temperature, and the state of putrefaction of the remains. Changes in brain, rectal, and liver temperature can be used to estimate time of death, but they are not always reliable. A search of stomach contents may be of value. Remember, the estimation is very broad; so its significance may be negligible to the investigation. Later you can match these findings at the scene with autopsy findings to determine the manner of death.

Slight abrasions may be the only outer signs of severe internal injuries. Or they may suggest the manner of death. Small fingernail marks and abrasions on the neck are notably important to manual strangulation cases. Likewise, slight abrasions of the nose, mouth, and neck, especially of infants, receive special attention. These marks may point to asphyxia by smothering. Similarly, abrasion and bruising of the thighs, especially on the inner side, raises the suspicion of rape. In many cases, abrasions and bruises are caused by the same force. They may obscure each other to some degree.

If a bullet, a blade, or other weapon passed through the victim's clothing, obtain the clothes and forward them to the lab for analysis. If possible, you remove or help remove them. Place each item in a separate, marked paper bag. If the garments are damp, they should be air dried by hanging in a dry room to preserve the evidence. Clothing should be cut from the body only as a last resort. Do not cut through a *hole* in the garment that might be connected to the cause of death. The pathologist should have the

chance to examine and describe the clothing to match it to injuries on the body.

Dragging a body produces changes in the clothing and the body that can be very confusing if you do not realize the cause. If a body is dragged by the feet, the primary pressure area will be the thorax, and clothes around the thorax will be pushed upward. If the breasts become exposed, particularly on females, dragging will produce numerous parallel superficial abrasions or scratches on the surface. When the surface is extremely rough or contains sharp stones, the abrasions can be deep. If a body is dragged by the shoulders, the clothes of the lower body may be pushed downward. Bruising can be severe if the body is dragged by both shoulders and legs causing multiple abrasions.

These injuries can be distinguished from those of rape or murder by their characteristic parallel, vertical-oriented abrasions. These usually occur on the thorax front or back and on the buttocks. The series of parallel abrasions will be oriented roughly from the head to toe or vice versa. It is always worthwhile to explore these abrasions with a magnifying glass and retain samples of any foreign material that may be present.

Look for metal items, such as pocket knives, watches, rings, cigarette lighters, and belt buckles. They may be separated from the victim. Or they may be mixed with similar objects from other victims. Unless you record the exact place where these items were found, they have little value as identification.

All suspected weapons, shell casings, expended bullets, and the like recovered at the scene or during autopsies must have laboratory tests to identify them and connect them with the death. Release the body only when you are sure it will no longer be needed.

### RECONSTRUCTING THE SCENE

Once the victim is removed, you can sketch the scene again, showing the action of the event and the relative positions of pertinent evidence. You may want to have someone role play the victim. Then you can replay the action and record the results with still

photographs or motion pictures to study later. The role player should be about the same height and weight as the victim. This replay of the action can help you learn if or how force was applied. It also may show if an injury was caused in a certain way or from a certain direction. Note circumstance of use and placement and conditions of any weapon.

In alleged homicide investigations it is not unusual to find the body has been removed and the scene returned to its natural state. The body may even have been interred. In cases like this, in addition to reconstructing the scene, closely check records of any other investigations of the death. Seek to establish investigative leads not yet explored. You may need to have the body exhumed for an examination by medical personnel.

Release the scene of a death only when it is certain it will no longer be needed. Early release of a scene often causes the loss of evidence and may preclude a later recheck of the scene.

### IDENTIFYING THE DECEASED

The means of identifying bodies are many and varied. Often the highly technical skills of professional medical personnel are needed. Be sure to note the victim's age, sex, race, weight, height, hair color and style, eye color, skin blemishes, and odd dental characteristics. Check metal tags, identification cards, and other documents. If a document seems to have been tampered with or if it has been mutilated or burned, send it to the crime lab for study. Articles of clothing may need laboratory testing and extensive tracing of chronological ownership. Of main concern is the size, type, and condition of the clothing; laundry and drycleaning marks; and foreign substances stuck to the clothing.

Do not completely rely on visually identifying the victim nor on written identifi-

cation and personal items found on a body. Fingerprints are the best means of identification. When you cannot obtain fingerprints, your next best means are dental charts. Medical records of injuries like broken bones or of operations like surgical repairs or removal of parts of the body are also very useful. Scars and tattoos may also help.

### CHECKING MOTIVE AND OPPORTUNITY

In homicide cases, if there is no known suspect, or if a suspected or accused person denies being involved, it is very important to identify persons who could have a motive to commit the crime and persons who would have had an opportunity to commit the crime. These two factors are of equal value. Which one you consider first depends on the facts of your case. If you find a person who could have a motive, find out if he or she had the chance to commit the crime. Conversely, if a person seems to have had a chance to commit the crime, find out if he or she had a motive.

The facts surrounding motive and opportunity often surface through questioning. Ask witnesses what they saw. Pay special attention to events that may hint of a motive. Question acquaintances and relatives of the victim to learn of persons who may have had motive or chance. Homicide is often a crime of passion committed by someone well-known by or related to the victim. Ask associates of suspects what they know about the suspects' relationship with the victim. Question the suspects about their relationship with the victim. Find out the whereabouts and the activities of a suspect before, during, and after the incident. Check alibis having a bearing on the chance to commit the crime. Sometimes, to check leads or motives, you may want to conduct a surveillance or an intensive investigation.

### DEATHS INVOLVING FIREARMS

Homicides and suicides occur most commonly as a result of the discharge of a firearm. Accidental death from the discharge of a firearm is also common. These violent

deaths often are not witnessed. But unlike other forms of violent or unnatural death, deaths from firearms often have trace evidence left by the weapon in or near the

victim's body. This evidence can be scientifically compared with suspect weapons. And it often can provide information about circumstances surrounding the death.

In a medicolegal investigation of death by firearms, scientific evidence is very important. Deciding the manner of the death, and solving the homicide if there is one, often hinges on that evidence. Thus, you must take every care to ensure such evidence is not lost. For example, gunshot primer residue must always be collected from the victim's hands at the scene if this can be done. The residue is very easily lost when a body is moved. If it cannot be collected at the scene, direct transporting personnel to touch and move the hands just as little as possible.

A study of gunshot wounds in a body can tell much about the type of gun involved. It can identify ammunition, range of fire, and direction and angle of fire. Sometimes it can tell the number of shots that hit the body. And it can give an idea of the fatal or disabling effects of an injury.

### BULLET WOUNDS

A bullet passing through a body makes a wound which have traits that can be recognized. But all wounds must be medically confirmed during an autopsy. You can usually tell entry wounds from exit wounds. However, sometimes the distinction is hard to make. External determination is hard if bodies have begun to decompose or have been mangled. The uneven surface and tumbling action of ricocheting bullets may

make ragged punctures. Bullets passing across a body can cut gashes that may look like knife wounds. And the energy of a high-speed bullet destroys tissue as the shock waves of its impact radiates away from the bullet. This makes a track of permanently disrupted tissue much wider than the bullet.

In tough cases, inspecting marks and effects on clothing may be the best way to tell the direction of the bullet's flight. Autopsy examination of the bullet's track may show the path of travel by pieces of cloth, metal, and bone fragments carried forward by the bullet. Metal debris is scientifically detectable by spectrography and X-ray methods. If present, it is heavier at entrance wounds than exit wounds when the wound is in a fleshy area. Also, the nature of bone damage often shows the path of travel of the bullet. And determining which wounds are exit wounds and eliminating them from consideration helps locate entrance wounds.

### Entrance Wounds

Entrance wounds are commonly round, regular holes showing minor bleeding. Often, skin resistance is stretched by the impact of the bullet. This makes the hole somewhat smaller than the bullet. Sometimes a narrow ring around the entrance shows grayish soiling from carbon and oils on the bullet and a reddish-brown abrasion collar caused by the bullet's impact. Some bullet entry wounds are inconspicuous or hidden. Such wounds are often of small caliber. They may be hidden under clothing, in hair, in body folds or openings, or behind closed eyelids.

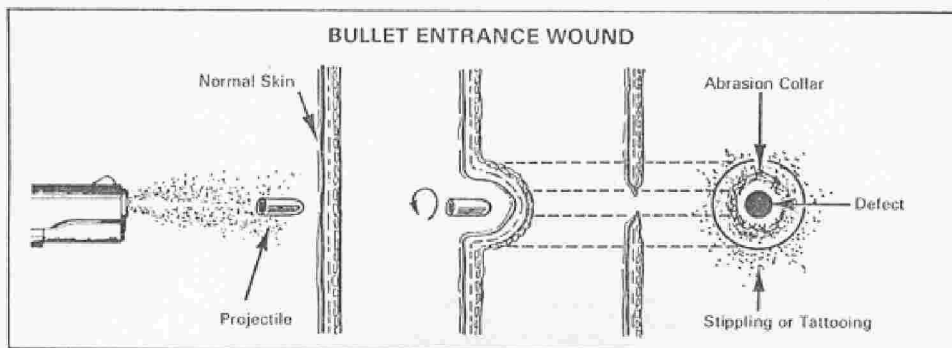



Identifying entrance wounds does not always tell the number of shots fired into the body. A single bullet can sometimes account for a number of entry wounds by piercing the body more than once. For example, a bullet may go through an arm before entering the torso. One of the aims of a pathologist's tracing of the path of the bullet is to try to match multiple wounds to the same bullet. A bullet striking a bony surface at an angle may split into two or more projectiles. The multiple projectiles can cause many exit and reentry holes. Ricocheting bullet pieces may also cause several wounds from a single bullet. On the other hand, more than one bullet may go through the same entrance wound. In one rare suicide case, a defective round failed to exit the barrel and a second round pushed the first in tandem through a single entrance.

Bullets and other products of a weapon's discharge have characteristic effects on skin and clothing. These effects can indicate the distance from which the gun was fired. Contact and near contact wounds are made with the gun muzzle held against or less than an inch from the victim. Contact wounds, especially the ones on bony surfaces, are likely to be large, ragged stellate wounds. The explosive force of gases from the discharge often tears skin and tissues around the bullet hole, producing ragged everted lacerations radiating from the hole. But a contact wound

made when exploding gases are received and expended by a large body cavity, like the chest, may not be large or irregular. On the other hand, a contact wound to the head made by a high-powered rifle may show massive bursting fractures of the skull from the explosive effect of gas forced into the skull where it has no chance to expand. Contact wounds from small caliber guns like a .25- or .22-caliber pistol tend to be smaller and less devastating than such wounds from larger caliber weapons. This is because the discharge from small caliber weapons may not be forceful enough to disrupt the surrounding tissues.

**Contact wounds** leave an abrasion collar. The edges of the contact wound and the bullet track are burned. If the gun is fired through clothing, the surrounding fabric is also burned. The flame and smoke may cause a sooty, grimy halo around the wound. But when the gun's muzzle is held tightly against the skin, the bullet hole is not "tattooed" with powder grains embedded in the surrounding skin like it is in intermediate-range wounds. This is because most of the unburned powder and other explosive products are blown right into the bullet track. The contact wound may also show a bruise pattern from swelling gases blowing the skin back against the gun's muzzle. It may be shaped like the gun's muzzle end, sights, or extractor spring rod.

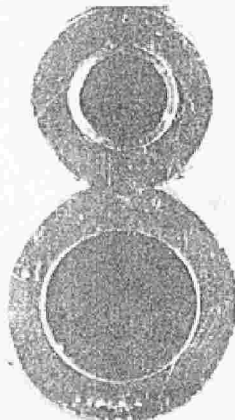

The bruise on this contact wound repeats the pattern of the over-and-under, .22-caliber rifle that caused it. Note also the even-edges of the small caliber's entry wound.

**Intermediate-range wounds** are made when the muzzle is held between 1 and 48 inches from the victim. The wounds are often round, but their edges may show minor splitting. They differ from contact or longer-range wounds by having burns and powder tattooing in the skin around the bullet hole. Powder residues and other discharge products are projected onto the victim in ample amounts when a gun is fired within 2 feet of the target. Recognizing powder marks and residues can help you tell entrance wounds from exit wounds. Their pattern and composition help you deduce the range of fire and the kind of ammunition used. Precise range of fire tests can be made by laboratory test-firing the same weapon and ammunition. Types of powder residues can also be distinguished by chemical, photographic, radiographic, and spectrographic tests.

The burned and tattooed area is roughly circular. It becomes larger and more diffused as the distance between weapon and victim grows. The area has three zones. The flame zone is the zone of burned skin around and in the bullet hole. This is surrounded by the second zone where most tattooing powder grains and combustion products burn and stick to the skin. The last zone is under the skin, where sparsely scattered powder grains and residues are embedded in the dermis. Washing will not remove powder grains in the dermis.

If the burned, tattooed, and abraded areas form a concentric circular margin around the entry wound, the bullet probably struck the body at right angles. Bullets striking at a shallower angle show marginal bruising and abrasions at the point where the bullet first meets the surface. Bullets striking at extreme angles may cause shallow furrowed wounds. These grazed, or tangential, wounds may be followed by an entrance wound. Or they may be followed by closely spaced entrance and exit wounds. It depends on the conformation of body surface in the path of the bullet.

If a gun is fired at close range and at an angle to the body, powder marks will seem to spread away from the bullet hole in an uneven V-shape. The point of the V will point toward the weapon. The size of the ammunition and the type of powder also affect the nature and extent of powder residues. At a distance of 3 to 4 feet, powder marks may not be present on a victim shot with a handgun.

**Long-range wounds** are made by muzzles held more than 48 inches from the victim. The wounds are generally rounded holes with circular abrasion collars. There are no burns or powder tattooing. Small caliber contact wounds and other contact wounds over soft-tissue areas may look like long-range wounds. But they can be distinguished by the powder residues deep in the tissues in the bullet track.

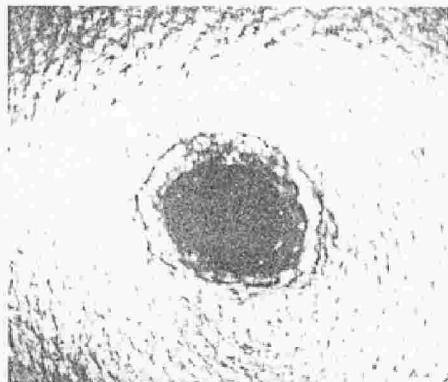
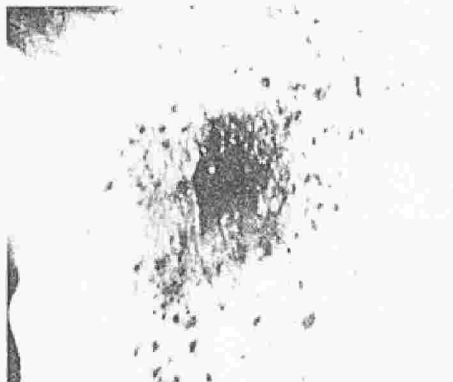

The characteristic burns and powder tattooing in the skin around an intermediate-range wound contrast markedly with the rounded hole, and circular abrasion collar of the long-range wound. Long range wounds and some contact wounds sometimes look similar, but long range wounds have no evidence of powder burn, inside or out.

### Exit Wounds

Exit wounds often show more damage than entrance wounds. Exit wounds are ragged and rough in shape. And they are often larger than the bullet itself. Tissues, compressed in front of the bullet, burst when the bullet breaks through and exits the body. Also, the bullet is often fragmented, deformed, and tumbled by impact. It is therefore more destructive. Thus, exit wounds may bleed more than entrance wounds. And pieces of internal tissue may protrude from the wound.

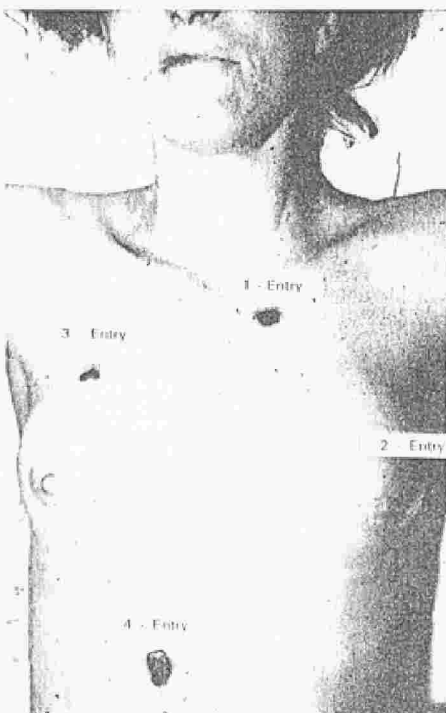

The unexpected locales of the exit wounds are the result of the bullets changing paths from contact with internal organs and bones. The uneven livor mortis is the result of pressure, from a strap on the left shoulder and from the shoulder blades, that kept the blood from settling evenly.

### SHOTGUN PELLET WOUNDS

Shotgun wounds are very different from wounds caused by other firearms. The destructive force of a shotgun blast at close range is great. If the wound is to the head, the shape of the head may be greatly changed.

Because a bullet loses momentum as it passes through the body and its tough, elastic skin, it sometimes uses up its remaining energy at the point of exit. Thus a bullet may be found protruding from the skin or loose in a victim's clothing. It may also be found under the skin, where it has caused swelling or bruising. If a bullet is lodged in a body, advise the surgeon of its potential value as evidence. Request he not probe for the bullet except as a last resort. If probing is needed, request that rubber tipped forceps be used to remove bullet.

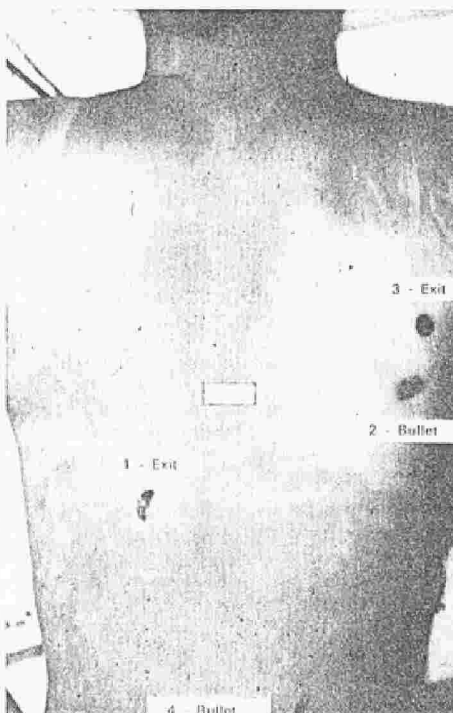

Large sections of the head or face may be blown away. Close-range wounds of the trunk and abdomen may cause loops of intestine or other organs to hang out of the body. Or it may blow away a large portion of a victim's body.

When a shotgun is fired from a distance of 10 feet or less, the charge strikes as a fairly compact mass. It leaves a large central, circular hole with very ragged edges from the many single and overlapping punctures made by the shotgun pellets. This is known as the cookie cutter effect. Scattered around the large central hole are smaller holes made by individual shot beginning to disperse in flight. When a shotgun is fired at close range, the wounds are grossly burned and tattooed. As the distance increases between weapon and victim, the wound shows less tattooing and no burning. Beyond 10 feet the shot spreads in flight and strikes the body in a more scattered grouping so that no central hole occurs.

The length of the shotgun's barrel and the type of ammunition also influence the spray of the shot and the scattered pattern of the wound. A sawed-off barrel allows quicker spreading. And the spray may be cut if the shotgun is choke-bored. The slightly narrowed muzzle focuses the shot and delays its spraying. Birdshot, even when fired at close range, usually does not go through the trunk or abdomen of an adult. But when the shot load goes through a thinner portion of the body like the neck, limb, or shoulder, it makes large lacerated exit wounds. Sometimes small, ragged exit wounds are

made when only some of the birdshot exits the body. At close range, buckshot, having a greater weight and energy, causes wounds similar to those made by large bullets.

Shotgun pellets cannot be linked to a certain gun by ballistics markings as rifled bullets can. However, the size of shot may be learned from printed material on the top wad or by marks left in the wadding. It can also be learned from printed information in the shot column. The gun's gauge may be learned by comparing the diameter of the wad with other wads. If the wadding has not struck an intervening zone, it can be found within 50 feet of where the gun was fired. If the gun is fired within 10 feet of the victim, the wadding is often carried into the body with the shot.

## SHOOTINGS

For self-inflicted gunshot wounds, unless some special contraption is arranged, the victim generally must hold the gun close to his or her body. Rifles and shotguns are sometimes fired by using a stick or string hooked to the trigger guard or by pushing the trigger with a toe or a device. Riggings made to pull the trigger, or removal of a shoe, strongly suggest suicide. And because a suicide's hands may be close to the wound when it is caused, they may be bloodied by the entrance wound.



At less than 10 feet, pellets leave a central circular hole with ragged edges and many overlapping punctures. Fired at a distance, the pellets have a spreading flight pattern and leave no central hole.

Suicide wounds are usually single, close-range or contact wounds on a part of the body that is easily reached. But sometimes suicides shoot themselves more than once before being disabled or dying. The presence of misfired rounds in or ejected from a weapon may also hint at suicide. Suicides sometimes fire shots to check the weapon while working up nerve to complete the act. Or they may misfire the weapon from momentary loss of nerve.

Often suicides expose the part of the body being attacked. For example, they tend to open their shirts before placing the muzzles against their chests. The chest and abdomen are often the target when a rifle or shotgun is used. The temple, the mouth, and the chest over the heart are common sites for suicidal attacks with a handgun. But most handgun suicides attack the head just in front of and over the ear.

Suicide victims may guide the gun by holding the barrel with the nonfiring hand. In which case, that hand will have burns from the flame from the muzzle and breach. The hand may also show singed hairs and leave powder residues. But finding primer residue on a victim's hands is not in itself conclusive proof of suicide. It must be considered in light of other facts in the case. Residue can be present on a victim's hands because they were close to the muzzle blast of a shot fired by someone else.

Condition of the weapon can suggest the manner of death. The gun may be defective. Perhaps the gun's safety catch is defective. Or the gun may not have a safety catch. Perhaps the gun can be discharged by dropping it. Evidence may show that the trigger caught on something, discharging it accidentally. Finding a serviceable weapon, needing normal force to pull the trigger, with good safety devices, may help rule out accidental shooting.

Most accidental shootings occur because of a victim's careless handling of or unfamiliarity with a gun. Perhaps the victim was on a hunting trip or was cleaning, loading, or otherwise working on the weapon. Evidence may show that the victim was handling the weapon unsafely, showing how

another person killed himself, or playing "quick-draw." Children and young people often become accident victims by playing with guns.

Accidental deaths are often witnessed and reported. If the wounds are not self-inflicted, the report is often made by the person who fired the gun. Unwitnessed accidental gunshot deaths may look a lot like suicide. But, in most cases, the known attitude and life-style of the victim, plus the lack of a clear case for suicide or homicide are strong signs of an accident.

Most deaths due to multiple gunshot wounds have proven to be homicides. The murderer, usually related to or closely acquainted with the victim, fires in a fit of rage, panic, or other strong emotion.

The location and number of empty shell cases at the scene may tell you the number of shots fired and the relative positions of the gun and victim. Lining up the final resting point of the bullet, position of the victim, and entry and exit holes on the victim can help tell the position from which a gun was fired. And a gun may have been fired close to or while resting on some surface. If so, it will have left powder residue. This also may tell you the position from which the gun was fired. All feasible surfaces of weapons, shells, magazines, must be checked for fingerprints.

When you recover bullets at a crime scene, *record exact details*. Give the location and condition of the bullet, the type of material it pierced, and its depth of penetration. Note irregularities of size and shape and the approximate angle of impact. Note any other information which may help the lab examiner. And be sure to note in your crime scene sketch the point at which each discharged bullet or fired cartridge case was found.

Markings may be placed on a bullet by the weapon's bore. Other marks may be placed on the cartridge case by the firing pin, breach block, chamber extractor, and ejector. Also, a lead bullet impacting on cloth may receive a patterned impression of the fabric's weave. This may be useful to prove that a particular bullet passed through the victim.

At the laboratory, powder residues on evidence are tested chemically and microscopically. Bloodstains, hairs, fibers and similar trace evidence are identified and

compared. The lab may be able to tell from the residue or burns on the clothing the approximate range from which the bullet was fired.

## DEATHS INVOLVING ASPHYXIATION

When the body or any vital part of it is deprived of oxygen, asphyxia occurs. Death from asphyxia alone is most often due to natural or accidental causes. Many diseases and infections can hinder airways. And foreign bodies like meat or bone can become trapped in the throat or windpipe, causing asphyxia. Food particles are often the cause of accidental choking deaths in adults. Choking deaths of children are common from food and from small plastic or metal toys. And pressure on the outside of the chest that restricts breathing can cause asphyxia. This pressure can occur in cave-ins, building collapses, or traffic accidents.

Inhaling chemicals like ammonia, chloroform, carbon monoxide, and carbon dioxide also may cause asphyxia. Sometimes these chemicals are the cause of suicidal or homicidal deaths. Homicide and suicide by asphyxia alone are rare. But in learning the reasons for death by asphyxia, anything suspicious must be pursued through background investigation and autopsy. Only then can the death be ruled accidental or natural.

### STRANGLINGS

Strangulation is asphyxiation from compression on the neck. It can be done manually or with a ligature like a binder, a rope, a necktie. Strangulation may also be caused by hard blows to the neck. Judo or karate chops to the throat may cause damage to the larynx, followed by suffocation.

Manual strangulation is a homicide. A person cannot strangle himself with his hands, because when he loses consciousness his hands relax and his breathing resumes. In manual strangulation, the attacker's fingernails often make small tell-tale bruises or marks on the neck. But the marks on the neck will not show the direction from which the victim was attacked. Fingernails vary too much in size and shape. Another sign of

manual strangulation is hemorrhaging in the throat area. This can be seen in an autopsy. Sometimes a fracture of the hyoid bone, a U-shaped bone at the base of the tongue, is also found.

Strangulation by ligature may be homicidal or suicidal. It is a fairly common form of suicide, but it is a rare form of homicide. The ligature often is made from something handy at the scene. Pajamas, neckties, belts, electrical cords, ladies' stockings, and other items can be used. Strangulation by a garrote of rope or wire sometimes is used in homicidal strangulation, but it is not seen very often. Close inspection of the marks left on the skin may show the type of garrote used. If possible, *leave the ligature in place* for a pathologist to remove during the examination.

When you investigate a strangulation, search the scene and the victim for signs of struggle. Obtain fingernail scrapings. Check the body for signs of defense wounds that may suggest homicide. But look for the presence of hesitation marks hinting at attempted suicide by other means before ruling it a homicide.

### HANGINGS

Hanging is asphyxiation by strangulation using a line of rope, cord, or similar material to work against the hanging weight of the body. Hanging is most often suicidal. But sometimes it is accidental. It is seldom homicidal, except in lynchings.

A person does not have to be fully suspended to hang. Hanging may occur if a victim jumps or is pushed from a height while tied by a line to a rafter or a tree limb. If the height is more than just a few feet, the victim's neck may break. But the neck is seldom broken in suicidal or accidental hangings,

At the scene you must check the beam or rafter over which the line is laid for marks showing the direction of travel of the line. You may want to remove the line for inspection. The hanging line must be checked in a laboratory to learn if it pulled against the weight of the body. Inspect the scene for signs of a fight and signs of defensive marks or rope burns. But keep in mind that an unconscious victim may convulse, knocking over items in the immediate area.

When you take down the body, *do not untie the knots*. The type of knot may give you a lead to follow. Remove the hanging line from the victim's neck by cutting the line on the side opposite to the knot. Make a careful inspection of the groove around the neck. A close look at the edges of the groove will often show black and blue marks from minute bleeding. Ruptured blood vessels in the skin mean the victim was alive at the time of the hanging. But the lack of these marks does not necessarily mean the victim was dead at the time of hanging. Combined with other conditions, however, it could raise suspicions.

Note the position of the groove as it relates to the location of the knot. The mark of the ligature should agree with the location of the knot. For example, if the knot is in front of the face, the deepest part of the groove should be

on the nape of the neck. Anything different suggests homicide.

When a fixed knot is used in hanging, the groove will form an inverted V on the side of the knot. The bruise on the skin in the groove is greatest opposite the knot. It tapers off as it reaches the knot. If a slip knot is used, the groove may be uniform around the neck.

If the victim is nude, suspended before a mirror, or suspended in an unusual manner, you may suspect an accidental hanging from sexual activity. Accidental deaths may occur from autoerotic sexual acts using restraints like ropes, cords, chains, and handcuffs. The victim, trying to reach sexual contentment, uses these items to restrain his or her hands, arms, legs, and neck. When strain on the neck causes unconsciousness or when the victim loses balance during the act, accidents occur. The victims are unable to release themselves because of the binding on their hands, arms, and legs. They may end by hanging themselves. Sometimes, when they use binding material or plastic bags on their faces, they suffocate. A notable feature of this type of death is the presence of female attire and articles on or near a male body. And erotic material is often present. In the past, these deaths were often incorrectly labeled suicides. But they are accidental and they must be listed as such.

#### VISIBLE PATTERNS CHARACTERISTIC OF STRANGLINGS AND HANGINGS

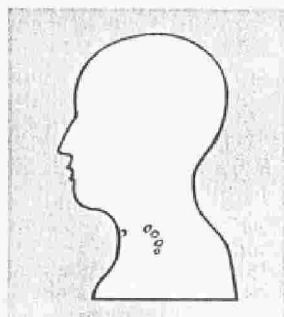

The finger bruises of a manual strangulation.

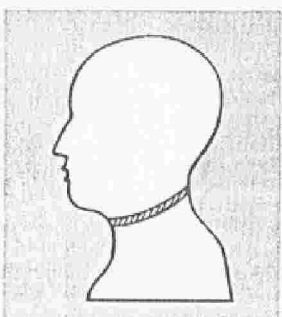

The even pressure and straight furrows left by a ligature.

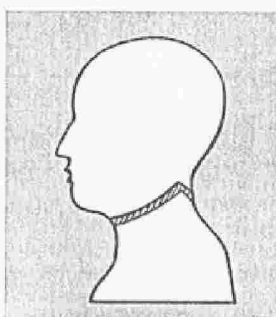

The inverted V and the angular furrows of a hanging.



Other accidental hangings differ from autoerotic deaths in the lack of female attire, erotic material, or constrained hands or feet. And accidental hangings often involve infants and young children. Infants can get caught in restraining devices. They can get their clothing caught on things. Or they can get their heads caught between crib or fence slots. If they are unable to get themselves free, they may strangle. For no known reason, young children, especially boys, will put nooses around their necks. They too may strangle to death.

### DROWNINGS

Drowning is asphyxiation from water or liquid being inhaled into the airways, blocking the passage of air to the lungs. Water inhaled into the windpipe causes violent choking. The choking irritates the mucous membranes of the airways causing a large amount of sticky mucus to form. The mucus, mixed with the water and agitated by violent attempts to breathe, turns into a thick sticky foam which fills the windpipe.

Most drownings occur when the victim submerges in a body of water. A small number of "drowning" deaths among swimmers are actually caused by their hearts stopping from the shock of submersion. Most commonly, a drowning victim has a violent spasm of the neck, throat, and chest muscles. This prevents breathing. The victim submerges, inhaling water. The victim may stay submerged the first time he goes under. Or he may go under and surface many times, until he can no longer struggle to the surface. Loss of consciousness often occurs fast. Because the human body is heavier than water, when unconsciousness occurs, the victim sinks and tends to lay at the bottom with the head down. Breathing may continue briefly with varying amounts of water inhaled. The heart may beat briefly after breathing stops. Death by asphyxia occurs within a few minutes. Banning strong currents, a body sinks fast. It often comes to rest at a point close to where it was last seen on the surface.

Rigor mortis may start early because of violent muscular struggle. Postmortem lividity occurs, but is often a light red in color

and is most noted in the head and upper body. This is because of the body's tendency to sink head down. The foam that formed in the airway may exude from the mouth and nose. Often, the victim's hands will be grasping gravel, mud, or grass. The hands and fingertips may be scratched from violent grasping efforts. The palms may be cut by the fingernails during the hands' violent clenching motions. And medical laboratory study of the victim's bone marrow may show microscopic bodies. These factors are good circumstantial signs that the victim was alive when he entered the water.

After a few hours, depending on temperature and movement of the water, postmortem changes peculiar to submersion begin to occur. The skin, especially on the hands and feet, becomes bleached and waterlogged. Palms develop a very wrinkled condition called washer-woman hands. The constant churning of water currents or long periods of submersion may cause maceration. This is the wearing away of skin and flesh, especially of the hands and feet. Mutilation may occur from propellers of boats. This causes the appearance of postmortem dismemberment. Parts of the body, notably the face, may be eaten by marine life. As bacteria mounts in the body, putrefaction begins. As putrefaction progresses, gases build up in the tissues, organs and body cavities. The body becomes distended with gas. This makes the white foam in the airway come out of the nose and mouth. As the gases build up, the body becomes buoyant. Warm water speeds putrefaction; cold water slows it. In warm water, buoyancy may occur in a couple of days. In winter, the action may be slowed for weeks or until spring. As putrefaction advances, the skin loosens from the tissues. Sections of skin, especially hands, feet, and scalp, may fall from the body.

Unless a body is heavily weighted down or firmly caught on underwater debris, buoyancy will eventually cause it to rise to the top and float. If a body is prevented from rising, the gases eventually escape. Then buoyancy leaves and a body may stay down forever. When a "floater" rises and is exposed to the air, decomposition proceeds at a much faster rate.

Prolonged submersion and decaying may dim or destroy the external signs of asphyxia. Signs of violence or other cause of death may also be lost. Prolonged submergence makes death by drowning medically difficult to diagnose. But medical evidence may show signs of asphyxia like foam in the airways, and an enlarged heart. It may also show changes in the blood from water absorbed during drowning. Algae and other substances from the water may be found in the stomach or airways. Chemical tests during an autopsy can show if the person was alive when he entered the water. But chemical tests are nonspecific, and none are diagnostic of drowning.

Suicidal drownings in places like bathtubs are hard to distinguish from accidents unless a reason is suggested or some other means of suicide was also attempted. Check for marks which may show suicidal intent. A weighted body strongly suggests homicide. But suicides may weight their bodies to speed drowning and stop recovery. Inspect weighted bodies carefully for injuries suggesting homicide. See if the binding and weighting method could have been done by the victim. Check for self-inflicted injuries such as cut wrists or any other sign of suicide.

Homicidal drownings are rare. Unless accompanied by signs of homicidal violence or other such conditions, the autopsy shows only signs of asphyxia by drowning. There have been times when submerged bodies have shown no signs of violence, but, after the body dried out, bruise marks and small

abrasions appeared that could not be seen when wet.

### ELECTRICAL SHOCKS

Death by asphyxiation can occur as a result of electrical shock. The shock stops the action of the heart, and the brain, deprived of oxygen, ceases its function. The effect of electrical shock on a person depends on many things. It depends on their health. It also depends on their location and how wet or dry it is. And it depends on the amount of voltage they receive, how long they are in contact with this voltage, and the after-effects of the shock.

Electrical shocks often leave marks, although it is possible for a body not to show outer or inner damage. Usually electrical shocks leave entrance and exit wounds on the body. These have a grey or white puckered look. Severe burns from higher voltage, called Joule burns, are often brown and take the form of the thing that caused the fatal contact. Lightning deaths leave a characteristic mark that resembles a fern leaf. High-voltage shocks may leave marks where metal objects have melted on the person. And there may be extensive fractures of the bones.

When you investigate a death by electrical shock, you need to check weather conditions, electrical appliances the victim may have been using, and the victim's location and activity at the time of death to determine if the death is accidental or not. Deaths from electrical shock are most often accidental. Murder by electrocution is rare. But it is possible.

## DEATHS INVOLVING SHARP-EDGED INSTRUMENTS

The body's vital functions can be fatally impaired by injuries from sharp-edged instruments. Deaths or injuries from stabbing, cutting, and chopping are hard to evaluate without extensive experience. But the type of wound and the victim's personal history can help decide if death was an accident, a suicide, or a homicide.

### STABBINGS

Stab wounds may be made by any object with a fairly sharp point. Knives, scissors, ice

picks, triangular files, or hat pins can all make stab wounds. Sometimes stab wounds look like other kinds of wounds. A wound made with a stiletto or ice pick may look like a bullet wound. And the reverse may be true. If examination fails to show a sure sign of stabbing, the wound may have been made in some other way. X-rays may help to locate an unsuspected bullet or piece of a weapon, such as a knife or stiletto, which may be inside the body. Most stab wounds involve some cutting. This occurs as the weapon is pushed in or drawn out.

The shape of the wound depends on the direction from which the weapon penetrates. It also depends on the shape of the weapon. And it depends on the movement of the weapon while in the wound. For instance, a flat blade piercing a body at a right angle to the surface of the skin often causes an oval-shaped wound with pointed ends. If the blade's penetration is parallel to the cleavage lines, the wound is more or less closed. However, if the wound is at right angles to the direction of the cleavage lines, the sides pull because the fibers are elastic. A gaping wound is made. If the blade pierces a body at less than a right angle, it makes a beveled wound. If the blade moves around in the wound, an uneven-shaped scrimmage wound is made. Often the weapon is turned slightly as it is withdrawn. This causes a wound that has a notch in one side.

The depth and shape of a fatal stab wound, fixed during an autopsy, may give a clue to the type of weapon used. The track of a weapon may be very clear in fleshy areas. However, when a weapon penetrates inner organs, its track may not be accurate. Inner organs change in shape and position after death and when a body is moved. Also, a strong stabbing force against a soft area like the stomach can depress the area, making the wound deeper than the true length of the weapon. Likewise, a longer blade may not penetrate its full length. Then the wound path is shorter than the blade.

A homicidal stab wound often penetrates a victim's clothing. For this reason you must take special care when removing and checking the victim's clothing. Many times the clothing matches the real width of the weapon better than the wound does.

Pierced bony surfaces like the skull, sternum, or spine often show the shape of the part of the weapon that passed through the bone. And sometimes weapons break off or are left in the bone. The blade or portions of it may project from the inner part of the bone. If a blade is broken in a fatal stab wound, the part of the bone with the blade in it may be removed at the autopsy. It can be used as evidence of the corpus delicti, especially if the matching part of the weapon has been preserved as evidence.

To tell if a wound was made before or after death is difficult. A good inspection of the wound made before the body is moved is very important. If the wound was made before death there should be evidence of blood clot, swelling, wound healing, or infection.

Accidental stab wound deaths are rare. When they do occur, they are often caused by the victim's falling through glass doors or windows. The victim is stabbed by the larger pieces of broken glass. Other stabbing accidents may occur when victims fall on sharp pointed surfaces of tools or equipment. Sometimes victims are pierced by large splinters, by vehicle surfaces, or by horns or tusks of animals.

Most fatal stab wounds are homicidal. Often there is only one wound which pierces a vital organ or nerve center causing death from shock, hemorrhage, or the ceasing of a vital function. Homicidal stab wounds often appear on the back, neck, and upper chest. When many wounds are present on different parts of the body, homicide is strongly indicated. Wounds of the same depth, wounds of nonvital areas, scrimmage wounds, and multiple wounds of a vital area strongly support homicide. Several stab wounds to the breasts and genitals are suggestive of a sex-related homicide. And defense-type wounds on hands and arms and wounds to the back or other areas not easily reached by the victim hint of homicide.

Many stabbings are not instantly fatal. The victim may live for days and then die from acute infection or other medical problems. Stabbings usually are not immediately disabling. Unless the victim is unconscious or otherwise helpless, the scene is likely to show signs of struggle. Signs of flight and traces of blood are likely to be scattered over a large area.

Suicides most frequently stab themselves in the chest over the heart. But suicidal stab wounds may be made on any area of the body that can easily be reached. Like suicidal shootings, the victim will often open up clothing or uncover the selected stab area. Often the knife is left sticking in the wound.

In some cases, the suicide may jab the weapon into his chest a number of times. In such cases, the wounds often vary in depth.

Many of them may barely penetrate the chest. These hesitation wounds are made as the victim works up nerve to force the weapon through. Suicides sometimes stab themselves repeatedly in different directions, through the same wound, without completely withdrawing the weapon. This causes more stab tracks than outer wounds. Hesitation cuts under the wrist or thighs are good signs of the suicidal intent of a victim.

### CUTTINGS

A cut is an incised wound made by a sharp-edged object. The sharp edge is pressed to and drawn over the surface of the body to inflict a cut. Knives and razors account for almost all incised wounds. Cutting wounds can cause fatal hemorrhages and infection. They also can be fatal if the victim inhales blood from a cut airway. Cuts often are made on exposed surfaces like the head, neck, and arms. Where many cuts are involved, those on the palms of the hands and the outer surfaces of the forearms of the victim are often defensive

cuts. They may indicate a homicidal attack. Heavy maiming and dismemberment may accompany sex murders.

Homicidal cuttings are usually deep, clean cuts without hesitation marks. The wounds may be on various parts of the body. But most often they involve the head and neck. Homicidal slashing wounds may be present. Such a wound may be a single deep cut on the side of the face and neck. Or it may be one of many deep slashes crisscrossing each other.

Sometimes when a victim tries to dodge slashes there are small shallow cuts near larger wounds. These defensive wounds may be confused with suicidal hesitation cuts.

Suicidal cuts are often many, parallel, overlapping incisions of varying length and depth. Many times they have a lot of smaller shallow hesitation cuts on the lead edge of the injured area. Fatal suicidal cutting wounds are often on the throat. A right-handed suicide normally holds the weapon against the left

### WOUNDS INVOLVING SHARP-EDGED INSTRUMENTS



Closed wounds lie parallel to the lines of skin tension.



Gaping wounds lie at right angles to the lines of skin tension.

Knives cut and stab at the same time but the wounds are usually deeper than long

An oval wound is made by a flat blade piercing the body at a right angle.



A beveled wound is made by a blade piercing the body at less than a right angle.

A scrimmage wound is made by a knife being twisted in the body.

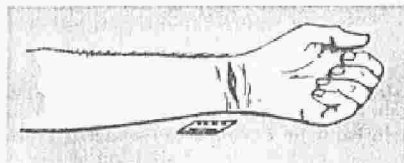

Hesitation cuts are the minor marks surrounding the final deep wound frequently observed in suicides

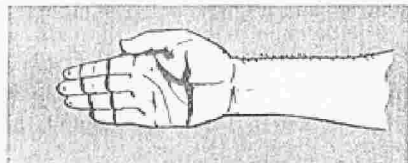

Defensive wounds are made by the victim's attempts to protect himself by grabbing the weapon.

side of the neck and draws the weapon to the right and across the throat. A left-handed suicide usually does the opposite. But sometimes a suicide holds the weapon against the neck on the same side as the cutting hand and pulls forward and downward across the throat. When a throat is cut, fatal bleeding sometimes results from a fairly shallow cut which severs a large vessel. Sometimes the cut starts shallow and gets deeper, cutting deep neck structure. The cut may reach the voicebox, deep vessels, windpipe, and esophagus. It may even scratch the spine. Often, a suicide slashes the wrist opposite to the cutting hand before attacking the throat.

Other self-induced cuts may be made to the groin, thighs, ankles, knees and the inside of the forearm at the elbow. Suicidal cuts on the limbs are often not fatal. Frequently found on persons who have killed themselves some other way, they support a judgment of death by suicide.

Accidental incised wounds are rarely fatal. They occur most often from broken glass or contact with moving machinery or sharp tools. Most times the situation clearly shows the accidental nature of the injury.

## DEATHS INVOLVING BLUNT FORCE

Blunt force damages the body by direct physical violence. Generalized blunt force affects the whole body or a large part of it. Deaths caused by such force may happen in vehicle accidents, explosions, or falls from a height. Localized blunt force impacts on a limited area. Death involving localized blunt force can be caused by contact with a fist, weapon, or foot.

Blunt force injuries of the skin and tissues under the skin are of three general types - abrasion, bruises, and lacerations. Abrasions are surface injuries to the outer layer of skin at the point of impact. An abrasion may duplicate the surface appearance of the impacting object. It may look like the grill pattern of an automobile or the rough edges of a file. It may look like a threader pipe or the treads of an automobile tire. Bite and nail marks are considered abrasions. But they actually may be small

A chopping wound is a mangling, tearing cut. The wound is usually made with a heavy instrument like a cleaver, a machete, a hatchet, or an ax. Death from chopping wounds may come from shock, hemorrhage, or interruption of vital functions.

Most chop wounds are homicidal. They are usually made on the head, neck, shoulders and arms. Injuries may be multiple. Injuries received by the victim in an attempt to defend himself may include total or partial loss of fingers, hands, or arms. Fatal accidental chop wounds sometimes occur from propeller blades of fans, boats, or planes. Suicidal chop wounds are rare.

Because the shape and size of chopping wounds often resemble the shape and size of the weapon that made them, autopsies may provide medical evidence. A pathologist may be able to determine the type of weapon that was used by examining the depth, width, and appearance of the wound and the amount of tissue damage. He may be able to link the injuries to a suspected weapon. It may even be possible to take tool mark impressions of the weapon from bone or cartilage.

puncture wounds. Abrasions normally are caused by direct violence from hands, blows of a weapon, or collision with a vehicle. They may also be caused as a body falls and strikes a surface.

The appearance of an abrasion, and its linear scratches on the skin, may show the direction of the injuring force. Often the end portion of the abrasion will show many small bits of loose, ragged skin. Abrasions on a live person seep blood and plasma. They develop reddish black scabs. Postmortem abrasions show little or no seepage, because blood circulation has ceased. Such abrasions look like translucent, yellow parchment as they dry. Sometimes patches of skin falling from a decaying body expose raw surfaces. These may dry like a reddish brown antemortem abrasion. But a pathologist may be able to confirm the lack of vital reactions, if decay is not too advanced.

Abrasions received at the time of death cannot be readily told from those received after death. But abrasions occurring well before death have a different appearance and color from postmortem abrasions. A pathologist can usually distinguish between them.

Bruises, or contusions, occur when blood escapes within tissues from small blood vessels ruptured by blunt force. A bruise is a red-blue area which is often raised or swollen. Unlike an abrasion, a bruise does not always lie at the point of impact. The blood may travel some distance in deeper tissues. And blows to the body may bruise body linings and inner organs without producing external bruises. Although patterned bruises are less common than patterned abrasions, they may occur and show the nature of the object that struck the body.

Distinguishing a bruise received at the time of death from one which occurred a few minutes before death is often not possible. But bruises made after death have a different appearance. They must be made by gross force to cause even minor bruising. They are not swollen, because circulation has ceased. Instead, they are often depressed at the center of impact. They are yellowish in color and translucent in appearance.

After decay starts, it may be hard to tell bruising from postmortem lividity marks. In early lividity, pressure applied to a mark blanches a lividity mark, but not a bruise. In later stages, a pathologist distinguishes bruising from lividity by microscopic inspection. Blood appears in the tissue in bruises, but only distends the vessels in lividity. However, as decay advances, gaseous pressure rises and postmortem rupture of many small vessels may occur. Then it becomes impossible to tell antemortem bruising from postmortem decay.

No precise estimate of the age of a bruise is practical. The color changes that occur as bruises age vary with the depth and size of the bruise. In general, a surface bruise is red-blue when recent. Within a week or two it looks greenish. Later it turns yellow. By the end of a month it has vanished.

The size of a bruise may indicate the degree of violence causing it. But not always. Females tend to bruise more readily than males. Bruises occur more easily on the very young, old, fat, soft-skinned, poorly-conditioned, and sick. And a light blow to soft tissues like the eyelid or genitalia may cause gross bruising, while a heavy blow to dense, fixed tissue like the scalp may cause only mild bruising.

#### BLUNT FORCE INJURIES TO THE SKIN AND TISSUES

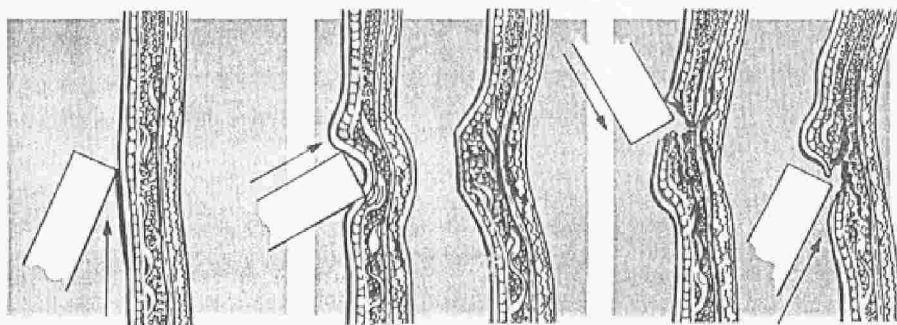

Abrasions are surface injuries to the outer layer of skin, grazing linear scratches in the direction of the force.

Bruises, or contusions, are ruptured small blood vessels under the skin, causing raised red-blue area at the point of impact.

Lacerations are ragged-edged depressions in the skin from tearing or splitting of tissue in the direction of the blunt force.



Lacerations are caused by a shearing force or violent depression to the skin, which tears or splits tissues. Lacerations may be caused by blows from fists, sticks, or hammers. They also may occur from the impact of a motor vehicle or as a result of a fall. Lacerations, characteristically, are bruised and ragged-edged. The tissues are unevenly divided and the blood vessels and nerves are crushed and torn. The crushed ends of vessels may show only slight bleeding. Lacerations may contain foreign material like soil or glass from the impacting object. Lacerations of the scalp, face, eyebrow, or skin near bone have a linear splitting effect. These may be hard to tell from cuts.

Normally it is not possible to tell lacerations made at the time of death from those made shortly after death. The distinction depends on the presence or absence of vital reactions like bleeding and bruising in the wound. Lacerations made during life tend to gape. But lacerations in heavy muscles like the thigh, especially those that cross the grain of the elastic tissue fibers, tend to gape at any time.

Homicidal deaths may occur from either generalized or localized blunt force. Victims may be struck with fists or blunt objects. Or they may be thrown from heights, pushed in front of moving vehicles, or crushed with heavy objects. Sometimes homicidal blunt force deaths involve fatal injuries from negligence. This may occur in highway accidents.

Suicidal deaths from blunt force usually involve generalized blunt force. The victim jumps from a high place or in front of a moving vehicle. But sometimes a suicide may ram his head into a wall or in some other way create enough impact or crushing force to cause fatal injuries. Accidental deaths from blunt force are usually falls.

Often your investigations of death involving generalized blunt force will show that the injuries have resulted from impact with a vehicle. And you must be able to link the vehicle to the victim by trace evidence left at the scene or found on the persons or vehicles involved.

If circumstances suggest a hit-and-run accident or a vehicular homicide you must

initiate an immediate search and apprehension plan. Such a plan may include setting up coordinated MP patrol activities and roadblocks. It may include searching and patrolling parking lots, service stations, residential parking areas, motels, taverns, bar rooms, garages, and body repair shops. If a military vehicle could be involved, it must include alerting and checking motor pools. And it includes checking known license and registration data at once.

At the scene, look for evidence supporting the crime and linking the vehicle and victim. Check skid marks to learn about the vehicle's speed, the alertness of the driver, and to check the accuracy of the driver's and witnesses' statements. Take samples of dirt from under the vehicle to link it to the point of impact and to use for future comparison. Photograph and cast tire tracks before they are disturbed. Take the bumper height measurements to match them to the victim's injuries. This may help you learn if the vehicle at the time of impact was braking, maintaining, or increasing its speed.

Collect material from the scene and from the victim or the victim's vehicle that may have come from the offender's vehicle. Broken glass, vehicle trimmings, paint chips, and liquids may identify vehicle-type and may be compared with a suspect's vehicle. Pieces of glass and paint too small for matching fractured surfaces can undergo spectrographic tests and other lab tests to learn specific gravity, refractive index, optical dispersion, and other physical properties to match it to the vehicles involved and to the manufacturer.

Be sure trace evidence from the victim like blood, body tissue, hairs, and textile fragments are also seized. And vehicles suspected of having been involved must be checked for signs of impact and traces of the victim or victim's clothing. Often, in hit-and-run accidents, the victim's clothing leaves patterned rub marks. The pattern may show in the chassis paint. It may also show on grease and mud on the undercarriage. Likewise, hand, finger, and even lip prints of the victim may be left on the vehicle. And hair, tissue, and bone fragments as well as fabric, fibers, and other trace evidence of the victim may be stuck to the suspect vehicle.



Blood of the victim, often found on the undercarriage, must be typed with a sample from the victim. And the sobriety of the victim at the time of death always must be learned.

Follow-up investigation may include checking on persons with a history of speeding and reckless or drunken driving. Check with insurance agents, on vehicle sales and on transfers of registration. Consider press, radio, and TV coverage. And check tradesmen, deliverymen, garbage collectors, and the like. Their schedules may place them on the scene at the time or day of the accident.

Contact medical facilities to see if anyone has sought medical attention after an accident. Check stolen vehicle reports. A driver of a hit-and-run vehicle may report that the vehicle was stolen. Likewise, a hit-and-run driver may file a false accident report to cover a real accident.

### BEATINGS

Beatings involve localized blunt force. Death from a beating is usually not planned. Beatings leave extensive bruises on a body. Autopsies often show ruptured vital organs and brain hemorrhaging. When a weapon is used in a beating, it often leaves distinct pattern injuries. They may help you learn the type of weapon used. When a person is kicked or stomped, the shoe often leaves impressions and clear cut marks on the clothing or body.

Sometimes, in a beating death, the body is moved and a simulated vehicle accident is staged. Or a vehicle is driven over the body to stage a hit-and-run accident. An autopsy may show that the injuries are not like motor vehicle injuries. Search the area. There may not be a point of impact. And a thorough search of the area may show evidence inconsistent with an accident.

### DEATHS INVOLVING FIRE

Most deaths by fire are accidental. But connecting the death and the cause of the fire may show that homicide is involved. The fire may have been the cause of death or it may have been used to try to cover up the crime. If homicide is suspected or, in fact, the case, you must take steps to investigate for arson. Sometimes a person who commits a homicide

### EXPLOSIONS

Most deaths from explosives are accidents resulting from blasts during training, construction, or military maneuvers. Homicides occur in which a deliberate blast is the cause of death. But more usually, explosions are used to hide a victim's identity or the real cause of death.

In an explosion a body may be shattered or hurled against a hard surface, causing blunt force injuries. It may receive many lacerations and punctures from pieces of the explosive device and nearby objects. It may be burned by thermal blast, flame, and steam. Compression injuries may occur in the lungs and elsewhere from swelling gases. Foreign material in the body must be examined at the autopsy to help learn the nature of the explosion and explosive device used.

### FALLS

Deaths from falls are usually accidental. A person may be pushed or thrown from a height, but such events are rare. It is sometimes helpful to consider the blood alcohol content of the victim. And you must consider the height from which the victim fell and the distance from the base of the object to the point of impact. Do not overlook the fact that a victim found at the very base of an object may have been knocked out and rolled over the edge. An inspection of the point of departure of the body must get ample attention.

### CRUSHINGS

Crushing deaths may occur in vehicle and industrial/construction accidents. These deaths may also occur from crowds in panic situations like fire in restaurants or theaters. The victims are usually the weak, the old, or the small.

with a firearm will try to hide the crime by setting fire to the scene. In cases of death by burning you should request that the remains be x-rayed. This may show the presence of a bullet in the body.

The two toughest facts to establish in a death by fire are the victim's identity and a

connection between the death and the cause of the fire. Investigating a death by fire is difficult. The victim may be mutilated by the fire, and the scene of the fire is often unavoidably disturbed by fire-fighting activities. Identifying unknown victims requires the help of pathologists. They can check skeletal remains for size, race, and sex distinctions. And they can compare the remains to dental records and X-rays.

Your investigation of a death from fire depends greatly on the pathologist's report of the cause of death. If the victim was alive at the time of burning, the autopsy will show inhaled smoke particles or carbon monoxide in the blood. The presence of these suggests life at the time the fire started, but its absence does not support death prior to the fire. A body is rarely burned to the point that a meaningful autopsy is not possible. Even if

death occurs quite some time before the fire is brought under control, and the body is badly charred, the inner organs are usually well-enough preserved. The cremation of a body takes one and one-half hours at 1600° to 1800° Fahrenheit. Even then bone fragments are seen. The ordinary housefire rarely exceeds 1200° Fahrenheit.

You must rely on the pathologist to identify wounds on a burn victim. There are many types of burn injuries that are misleading at first glance. The body may have a "pugilistic attitude." Its fists and arms may be drawn up like a boxer's stance from contracting muscles and skin. Bones fracture in an odd, curved way when cooling begins. Skull fractures may be present. But the cracks, radiating from a common center, are made by the release of steam pressure rather than blunt force.

## DEATHS INVOLVING SEXUAL ASSAULT

Deaths may come from sexual assault, either directly or indirectly. The actual way the victim is killed may or may not clearly show a sexual reason. The most common means are strangulation and stabbing.

Anytime a violent death involves a woman or a child of either sex, sexual assault or abuse may be involved. Here, medical and psychiatric opinions must be requested. Bruising of the arms, inner thighs, and of the genitalia is commonly sustained by victims

of rape. Do not be misled by the fact evidence of normal sexual intercourse is not present. Anal and oral openings must be checked.

You must be alert for signs in the crime scene or on the body that might show sexual assault. These signs may differ broadly, from strange maiming of sex organs to merely an odd arrangement of clothing. Use sexual assault investigation methods, and closely inspect the crime scene and trace evidence to help track the criminal.

## DEATHS INVOLVING TOXIC SUBSTANCES

Death from toxic substances may occur if substances safe only for external use are taken internally. And death from toxic levels of substances safe for internal use may occur if the substances are taken in amounts greater than the body can support. In either case, the death may be an accident, a suicide, or a homicide.

### POISONINGS

The term poison is relative when describing a substance. A poison is any agent, that, when introduced into a living organism, causes a detrimental or destructive effect.

Accidental death may result from industrial, home, or food poisoning.

Sometimes poisonings result from gross negligence like that occurring in bad liquor or criminal abortion cases. Poisoning as the result of bad liquor is a broader, more organized manifestation of crime than an individual homicide. Solving these cases usually requires help from civilian authorities. These cases are not common to CONUS installations. But they have occurred in oversea areas where acceptable liquor is not available in quantity, and where there are black-market transactions in liquor. They also have occurred where insurgent forces have used poisoned liquor as a method of offensive operations against US military personnel.

Although homicide by poisoning is fairly rare, it must not be ruled out without a thorough investigation. Murder by poison can often be made to look like suicide. For example, the scene of a murder by poisonous gas may be fixed to look like that of a suicide or an accident.

Investigation of the crime scene is of special importance in the case of poisoning, because postmortem detection of poison may be difficult if its presence is not suspected. The presence of any one poison may be so hard to find that it may not be identified unless medical personnel have some idea of the type of poison they are looking for. The crime scene search for such poisons is most important.

When death is suspected to be the result of poison, it is important for you to give the pathologist performing the autopsy as much information as you can about the circumstances of death, the on-the-scene investigation, and the type of poison suspected. If you provide this information before the postmortem examination it allows the pathologist to use the right autopsy methods and to keep good specimens for toxicological tests.

### GROUPINGS OF COMMON POISONS

#### ORGANIC POISONS

Volatile	Nonvolatile
Ethyl alcohol	Alkaloids (heroin, cocaine)
Aniline	Barbiturates
Phenol	Glycosides (digitalis)
Gasoline	Synthetic drugs
Benzene	Miscellaneous
Chloral hydrate	(botulinus toxin, snake venom)

#### INORGANIC POISONS

Metallic	Nonmetallic
Arsenic	Cyanides
Mercury	Flouride
Lead	Iodine
Other metals	Strong acids
	Strong oxidants
	Gases

The Army Medical Department must conduct a medical inquiry to learn the immediate cause of a death by suspected poisoning. Results of the inquiry are recorded in the postmortem report. The report is a full record of all that medical authorities know about the person who has died. It includes a record of—

- Clinical treatment given victim.
- Utterances, statements or accusations made by victim before death.
- Known facts pertaining to death.
- Immediate cause of death.
- Autopsy.
- Pathological and toxicological examination conducted to support the autopsy.
- Medical examinations of items of physical evidence.

The autopsy may tell the specific poison that caused the death, its concentration in the body, and the period of time the poison was in contact with the soft tissue before and after death. In some cases the specific poison may be unidentifiable because the dose was too small to detect or the materials in the compound were the same as natural body products.

Ask the pathologist to obtain specimens of the victim's blood, bile, gastric contents, and urine. These samples can be sent to the USACIL, if they are not needed by medical personnel for diagnostic and autopsy purposes. The laboratory will try to learn if poison is present. Remember that body fluids found on a floor are likely to be contaminated. They are little use in toxicological tests for poisons. Nor is fecal matter a good source of specimen for poisons.

Take samples of food, medicines, beverages, narcotics, fuels, and chemicals that the victim may have consumed. Sinks, pipes, drain traps, garbage cans, cupboards and refrigerators may contain evidence of the poison. Poison also can be easily hidden in spices, sugar, flour, baking soda and the like. Soiled linen or clothing may contain traces of poison in stains from food, liquid, vomit, urine, or other matter. Collect spilled liquid in a filter paper and put it in a clean glass jar and seal it tightly. These samples must be submitted, despite an admission or

confession, in any case that may involve criminal charges.

Collect containers that could have held a substance consumed by the victim. Include cups, glasses, and utensils that may have been used to prepare or serve food or drink. Check medicine containers for prescription numbers and the name of the dispensing pharmacy. In difficult cases you may want to take the contents of the medicine chest to search for materials that might have been taken in amounts large enough to cause toxic effects. Be sure to seize any items like hypodermic needles and syringes that could introduce a poison into a victim's body.

Identification and analysis of the poison may help locate its source. Few laymen know enough about poison in pure form to purchase or obtain any but the most well-known types. But many common retail products, not often thought of as poison, are toxic under some conditions. It is these materials that will be easily accessible to the poisoner. And their very availability may cause you to overlook them. Household sprays, paint and paint solvents, pesticides, liquid fuels, patent medicines, many antiseptics, and some cosmetics contain poison.

To learn the source of a poison, consider its availability and who would have easiest access to it. A poisoner usually uses a poison he knows. His familiarity with a substance can come from his occupation, hobbies, or past experience. Hospitals, dispensaries, laboratories, pharmacies, and illicit narcotics channels can be sources of medicines and drugs to be used as poisons. Offices, homes, and grocery stores contain cleaning substances, rodent and insect poisons, and medicines that may be toxic. Depots, warehouses, storage areas, farms, and similar places may be sources of rodent and insect poisons. Motor pools, fuel depots, and other places containing fuels with alcoholic bases and cleaning and solvent compounds may also be sources.

Locating a poison's source and determining its availability may suggest the mode of poisoning. Knowing a poison was contained in a food or beverage may help you ascertain where the victim ate the food or

drank the beverage. The place where a poison takes effect is not always the place where the victim consumes the poison.

There are rarely, if ever, witnesses to an act of poisoning. Consequently, you must gather as much concrete evidence as possible to find out if a crime was, in fact, committed, and if so, who committed it. Such evidence is not limited to the poisonous substance.

To learn key information about the poisoning you must run a background check on the victim and his activities. Be sure to interview persons who may—

- Have witnessed the act of poisoning.
- Know of a suspect's utterances or actions that could establish a motive for the crime.
- Know what the victim ate or drank within the time he probably received the poison.
- Have sold drugs or medicines to the victim or suspects.
- Know of the victim's movements before he was stricken.
- Be familiar with the victim's eating and drinking habits, use of drugs or medicines, and attempts at self-medication or treatment from sources outside military medical channels.
- Be familiar with the victim's eating and drinking habits, use of drugs or medicines, and attempts at self-medication or treatment from sources outside military medical channels.
- Be familiar with the victim's financial status, family background, social life, or business associates.

## OVERDOSINGS

Preliminary inquiry into a death may suggest that a victim died from an overdose of drugs. General observations of the crime scene, the victim, the victim's clothing, or conclusions about the victim's life-style may suggest this. Note the quality and quantity of food and liquor supplies, the contents of a library, the style and condition of the furniture and decor. An astute evaluation of these items can give significant and reliable clues to the life-style of the drug victim. These clues may clarify the circumstances of the death or at least give explicit information concerning the resident and the life-style he or she may have led.

A frequent finding in suicide by drugs, regardless of whether or not the victim was a drug abuser, is the presence of a single capsule or tablet near the body. The single dose, commonly called the "tell-tale" tablet is usually a sample of the medication which is used to produce the fatal result. The tell-tale is usually lying free, but it may be in the medicine vial or ampule on the night table, bedding, or floor. There is often no satisfactory explanation of why a person planning suicide leaves this type of clue. The presence of a tell-tale is not generally public information, so the suicide is not really copying the style of other suicides.

Anyone who has experience in death investigations will confirm the premise that drug abusers seem to have significantly higher suicide rates than nonabusers. Suicides among drug abusers may be precipitated by the onset of various legal processes and the fear of confinement. Thus, a legal paper compelling an appearance in court found near a body can be considered the equivalent of a suicide note. It may even be true that abusive use of drugs, especially those recognized as dangerous, may be a symptom of a number of psychiatric conditions known to have a high incidence of suicide. This is especially important to bear in mind as you attempt to classify the manner of death when the cause of the death is related to the acute effects of an intravenous injection.

Suspicion of intravenous drug abuse should be aroused when long-sleeved garments are worn when the weather does not justify it. A sleeve that is severely wrinkled in contrast to the other shirt sleeve may have been used as a makeshift tourniquet. In cases where drug death is acute and related to intravenous drug abuse, frequently the abuser will not have had time to conceal his drug cache or paraphernalia prior to his or her collapse. Thus, cellophane envelopes, balloons or paper packets, syringes, needles, bottle caps or other devices used as cookers, cotton balls, matches, and cigarette lighters may be seen. Sometimes a tourniquet or other constrictive device may be dropped after a victim collapses. And syringes are commonly still at the injection site or grasped in the hand.

Check the body for needle marks and scars. Most intravenous drug injections are made with very small (26-gage) needles, which are designed for intradermal injection. If there have been only a few relatively recent injections not associated with puncture hemorrhage, you may need to use a magnifying glass to detect the punctures. In most chronic addicts, of course, there is no difficulty in detecting the tracks. In addition to the linear scars of intravenous drug use, flat ovoid or circular scars from lesions caused by unsterile injections given immediately under the skin sometimes may be seen. Chronic addicts may conceal punctures by injecting at unusual anatomic sites. They often inject in and around the genitalia, the nipples, the tongue, the mouth in general, and the scalp. Some addicts, who apparently do not care whether or not puncture sites are seen, may use the jugular vein in the neck to inject. Check the body for signs of nervous tension like the short, irregular edges of fingernails characteristic of nail biting or the yellow staining of the fingers characteristic of excessive smoking. Make detailed notations of pupillary diameter, even though this is not a reliable postmortem sign of drug abuse.

Toxicologic analyses do not always specify the exact doses of a drug. Thus, it can never be determined with any degree of specificity whether or not an abuser died accidentally from taking an overdose or decided to commit suicide by taking several doses at once. This is further confused by the fact that it is not really known how death is produced in a so-called "overdose," because it is rarely possible to show a large excess of drug material.

If the cause of death appears to be accidental and there are no signs of criminal acts or negligence, record any evidence supporting your judgment. Sometimes accidental death from drugs does not lend itself to early, clear resolution. You must rule out all aspects of other than natural cause. Make sure no motive for murder was found and no threats could be learned. See that persons who may have had a chance to cause ingestion of the lethal dose, either by force or trick, have been searched for leads and that there is no credible sign that the death was other than accidental.

## DEATHS INVOLVING INFANTS AND CHILDREN

Investigations of deaths of infants and children are particularly complex. You must proceed with great caution. You must fully coordinate your investigation with medical personnel, social welfare agencies, and SJA.

Suspicious deaths that involve infants and children can be grouped into three types - sudden infant death syndrome, infanticide, and battered child syndrome. Sudden infant death syndrome is believed to be the largest killer of children between one week and one year of age. The syndrome is also known as crib death, because this is where the death often occurs. In the past it was thought that these deaths were probably caused by the child smothering on bed clothes. Present medical research is investigating several theories, but none are yet proven. These deaths are generally held to be medically, rather than criminally, caused.

Infanticide is the criminal death of an infant by neglect or deliberation. Sometimes newborns are left to die of neglect in garbage cans, furnaces, restrooms, secluded places, and public dumps. Sometimes they are simply allowed to die at home or in a car in the expectation that they will be disposed of later. The cause of death in cases like these is usually a combination of acute congestion of the respiratory system, dehydration, and lack of basic life-sustaining care. Sometimes parents actively kill their infants. They may choke the baby with the umbilical cord, cup a hand over its mouth and nose, drown it in a bathtub, or drop it into a river or sewer. Sometimes, however, infants are stillborn or die soon after unattended births. Here, the criminal intent may only be to avoid reporting the birth and to illegally dispose of the body.

The battered child syndrome occurs in cases of child abuse. It accounts for a number of deaths of young children under violent conditions. Assigning criminal liability for deaths due to child abuse is often difficult. The victims are most often small children under three years old. If they are still alive when you first see them, they are usually unable or unwilling to describe what happened.

When investigating the death of a child, your first step is to get a brief background from the person finding the child. Where and in what position was the child found? When was the child last fed? Find out if the child had been ill or irritable the day or two before its death. Medical background, if known, can be of great benefit. If you are investigating an infant's death, try to learn of any problems during pregnancy and the infant's birth weight. Learn about routine visits to the doctor or well-baby clinics. Ask about the child's history of shots, illnesses, and hospital admissions. Learn the parents' ages, the number of children in the family, and if there is illness among family members.

Then check the body. Is its size consistent with its age? Consider the child's state of nutrition, sickness, dehydration, and cleanliness. Look for old scars and new or old bruises, lacerations, and abrasions. Examine the child's body, bed, and anything else relevant to the child. Include reports and interviews from neighbors, babysitters, and other children in the family.

You must find out how the child was cared for and who was responsible for the care. In most cases, there is one main person responsible for the care of the child. Get information about the family structure and number of relatives or persons frequenting the household. If the child has injuries, one of these parties may be responsible for the injuries. Include information about anyone who may feel competitive towards the child, like a mother's boyfriend. Information may be available from the local welfare agency and hospital and doctor records. Question the child's brothers, sisters, parents, neighbors, and babysitters. Many times a babysitter becomes the confidant of abused children, but from fear or disbelief she may not report the abuse that the children have related.

Cases of battered children often surface by conflicting statements of what the parents said happened and what the autopsy shows. You must listen for any conflicting statements, no matter how small. And in many cases the parents of a dead child have rehearsed their alibis.



The pathologist must have as much background about the child as possible before the autopsy. If there is no traumatic injury, the cause of death may be ruled as natural disease or crib death. When trauma from mechanical force is present, the distinction must be made between accidental injury and homicide. Bone injury may be caused by grabbing, gripping, and shaking the child by one or more extremities, as well as by blows to the child. Blunt force injury is the major cause of death of a battered child.

X-rays are crucial and vital. X-ray of new injuries will show the type and fracture, whether it be transversed or spiral from twisting forces. A radiologist can also find out the age of the injury. Some injuries to the head and stomach when used with X-ray evidence and autopsy findings of old injuries show repeated abuse and develop a pattern of injuries. Other injuries are of such a profound nature that accidental cause is hard to believe.

### INFANTICIDE

Determining that a death is a case of infanticide is often difficult. Most such deaths are due to asphyxia, which also can occur from natural and accidental conditions. But when death occurs from strangulation or other forms of direct violence or when the circumstances show criminal abandonment or disposal with criminal intent, infanticide is strongly suggested.

Three questions must be resolved in a suspected infanticide: Did the infant breathe after birth? Would the infant have lived if given proper care? And, what was the cause of death?

At autopsy, the pathologist checks the infant's lungs to learn if it breathed after birth. Usually the lungs of a stillborn and a live birth appear quite different. But sometimes the signs are not distinct. Then the pathologist must make vast microscopic and hydrostatic tests to find out if lung tissues have been aerated. Even then, there is a chance that breathing may have occurred only inside the birth canal or the uterus and the infant later choked on the umbilical cord during birth or was suffocated by extruded

membranes, blood, or the mother's weight and position. Tries at artificial respiration also may account for air in a stillborn's lungs. Even when signs of asphyxia are present, the death may be wholly natural or accidental.

The pathologist medically assesses the completeness of the infant's prenatal development. He also checks for certain vital changes which occur immediately after birth. He considers the apparent general health of the infant and evaluates any congenital defects and injuries received at birth. From his findings he decides whether or not the infant could have lived if given minimal care.

Identifying the victim may be impossible without finding the mother. The body of an abandoned infant usually has no identity of its own. And identifying the mother is not easy; she probably hid the pregnancy and birth. However, a suspect may be found if she seeks medical attention after the birth. She can be medically identified as the mother of the victim, if her physical condition is compatible with the birth of the dead infant. And blood tests can show close blood grouping. At all autopsies of abandoned infants, blood samples are taken and analyzed for future comparisons.

If a baby has died from injuries, you must check the child's medical record to see if the injuries were treated or hidden. Try to learn if the mother showed signs of mental depression after the birth of the child. In such a case she would be capable of seriously or fatally injuring the child or even herself. You should also review the mental history of the father. Medical personnel, neighbors, and friends of the parents can give you information about the temperament of the family. And military or civil police will have records of any complaints or past investigations of the parents.

### BATTERED CHILD SYNDROME

A major step in looking into the death of a battered child is to be able to spot signs of battering.

The victim of abuse is commonly an infant, most often under 3 years of age. One child in



the family is usually the main target of abuse. This child may be the product of an unwanted pregnancy or a premarital pregnancy. Or the child may be unwanted for other reasons. The home may be basically clean and the remainder of the children in it well cared for, fed, and clothed. It should be noted that sometimes the family is financially set, well educated, and socially oriented.

Many times battering parents were targets of abuse in their childhood. A statement such as, "If you think he is mistreated, you should have seen the way my old man kicked me around," shows a trend of child abuse from generation to generation. Parents raise their children the way their own parents raised them, because they know no other way. A battering parent often shows signs of emotional immaturity and mental and environmental stress.

Another factor which you must recognize is the presence of an extreme sense of competition between the parents. This competition can cause resentment that is taken out on the child. In most abusive families there is a constant stress of one kind or another.

Emotional outbursts from aggravation or frustration are responsible for many abusive deaths. Most parents feel some degree of guilt even though their children have been injured accidentally. They make statements like, "I shouldn't have bought him such a big bike," or "Why didn't I watch him more closely," or "Why did I let his bath water run so hot." The battering parent, on the other hand, often shows anger and a hostile, argumentative outlook. They may cry harassment on the part of an investigator.

You must assess the parents to try to detect undue frustration, belligerence, or nervousness when you suspect child abuse. But you must not overlook the chance that a child was beaten by a brother or sister. A small child, 18 months and older, may think and feel that its position in the family has been invaded by the arrival of a new baby. Parents may unthinkingly talk of the new baby in a way that the older child will resent. A child has many toys and objects at hand that can cause battering injuries.

The nonfatally battered child is hard to identify. This child may appear at medical facilities with extensive bruises, a broken arm, a cut lip, or a black eye. These injuries are easily explained by parents. A fall or a toy thrown by an older child are excuses often used by battering parents. Only repetitive injuries of this type can alert the doctor to a battered child. Often, to avoid discovery, the parent will take the child to a different doctor or hospital each time.

Some battered children show no outer signs of injuries. Others show extensive injuries. There may be deep bruises of the face and arms. Deep lacerations are rare. They are probably only seen when a blunt object is used to strike a child on the head or face. Lacerations on the inside of the mouth are more common, caused by them biting themselves when hit.

Almost all children have one or two scars from falls, but multiple scars on a small child shows a pattern leading you to conclude abuse. Small round burn scars may indicate cigarette or cigar burns. Burns on the buttocks may occur when an angry parent places a child on a hot surface to dry his wet pants. Sometimes a parent bites the child. The bite often leaves a pattern of human teeth marks on the child.

Your main tool is your eyesight. Look the child over, paying attention to signs that the child was abused. Look at parts of the child's body that are normally covered by clothing, like the arm pits and the inside of the upper thighs. Check the soles of the feet for burns. Look at the child's nutritional state, as well as his general cleanliness to check the parents care of the child.

Most of a battered child's internal injuries occur in the head or the stomach. The face and scalp may not show outer signs of abuse. But heavy hemorrhaging may be present under the skull. Subdural hematomas, common among battered children, take moderate to severe force to make. They may occur from a child being dropped to the floor or beaten repeatedly on the head. Or they may occur from a child being held by the ankles and swung against a wall. Or they may occur from a child being dropped down a staircase.

Blunt force injury to the stomach often causes a lacerated, torn, or ruptured spleen spilling into the peritoneal cavity. The small and large bowels may be perforated, causing the feces to enter into the cavity. Pancreatic substances or bile may be sent to the stomach by injuries to the liver or pancreas. All of

these injuries will cause much pain, crying, listlessness, shock and finally a coma. And because the lining of the stomach is soft, these injuries may not be apparent. One clue to intra-abdominal injury in the absence of obvious skin injury is a swollen stomach.

---

## CHAPTER 20

**Arson**

The willful burning of someone else's property is arson. No crime is more dangerous to human life than arson. Statistically, a murderer is unlikely to kill again. An arsonist, though, is a creature of habit. He will continue to set fires until caught. And no crime has a greater potential for loss of government property. A \$5,000 larceny is a big larceny, but a \$5,000 fire is a small fire. Thus all suspicious fires must be investigated to determine if the crime of arson has been committed.

Arson investigation is a highly complex process involving much vital work in a short period of time. Valuable and perishable evidence may be lost forever if it is not recognized and preserved immediately. Thus, an immediate response to fires and a close liaison with the fire department are essential elements of an arson investigation. Your close liaison with the local fire department can ensure you are notified immediately of any suspect or unusual fires in the area.

**FIRE CHEMISTRY AND BEHAVIOR**

There are two kinds of fires: accidental fires and incendiary or deliberately set fires. Most fires are accidental. To determine if a fire was accidental or incendiary, you must understand the basics of fire chemistry and behavior.

**CHEMISTRY**

Fire is a chemical reaction that takes place when fuel, heat, and oxygen combine in an uninhabited chain reaction. Fire can only exist when all four of these factors are present. Remove any one of the elements and the fire goes out because you have stopped the continuing chemical reaction.

Because only gases burn, solid and liquid fuels must be heated until they become vapor (gas) before they can burn. Heat chemically decomposes a fuel into its gaseous elements.

<b>CONTENTS</b>	
	Page
<b>FIRE CHEMISTRY AND BEHAVIOR</b> .....	<b>217</b>
Chemistry .....	217
Behavior .....	<b>218</b>
<b>FIRE INVESTIGATION</b> .....	<b>220</b>
Responding to the Scene .....	220
Observing the Spectators .....	222
Examining the Crime Scene .....	222
Assuming Responsibility .....	222
• Take Preliminary Actions .....	223
• Search Fire Scene .....	223
• Find Point of Origin .....	223
Eliminating Natural Causes .....	224
Establishing Proof of	
Incendiary Fire .....	225
• Look for Ignition Devices, Accelerants, and Trailers .....	225
• Check for Special Preparations for the Fire .....	226
Processing the Crime Scene .....	226
Identifying Suspects .....	227
Check for Motives .....	227
Look for Means and Opportunity .....	228

This decomposition is known as pyrolysis. For example, when wood is heated, it pyrolyzes to form hydrogen, oxygen, ethane and methane gases, and methyl alcohol. It is these highly flammable vapors which burn. Fuel in vapor form in its normal state, like natural gas, does not need to be pyrolyzed.

Most fuels are compounds of carbon, hydrogen, and oxygen along with traces of mineral matter. When the fuels burn completely and freely in air, the carbon reacts with the oxygen, forming carbon dioxide, and the hydrogen combines with the oxygen, forming water vapor. The mineral matter remains behind as ash. As the oxygen in the fuel is used up, oxygen is drawn from the air to continue the reaction. That is why drafts and air supplies directly affect the behavior of a fire. A fire started in a

completely enclosed space soon dies. It uses up all of the available oxygen and generates noncombustible gases that smother it. On the other hand, the rate of burning is greatly increased if a chimney effect exists when the hot gases and flame contact combustible material. Disasterous fires result in large buildings where elevator shafts or stairways served as chimneys to direct the uprushing flames and gases.

It takes heat to ignite the fuel and start the chemical reaction. Once ignition has taken place, however, the reaction (fire) produces its own heat and becomes self-generating as long as fuel and oxygen remain present.

The lowest temperature at which a fuel's vapor will ignite is that fuel's ignition point. Every substance has an ignition point. When vapor is heated above its ignition point in air, it will burst into flame without direct contact with a heat source. The degree of heat needed to reach ignition point is constant for a given substance. The amount of heat required for ignition depends on the size, temperature, and dryness of the substance. For example, a pine match stick and a pine 2 x 4 board both ignite at 502° Fahrenheit. But it takes a lot more heat to raise the board to 502° Fahrenheit. And it takes more heat to raise a wet 2 x 4 to 502° Fahrenheit than it does to raise a dry one.

In addition to having an ignition point, liquid fuels have known temperatures at which they form vapors, called flash points. A liquid fuel's flash point is not the same as its ignition point. The flash point is the lowest temperature at which the liquid begins evaporating. The ignition point is the temperature at which the resulting vapor ignites. For example, the flash point of gasoline is -45° Fahrenheit. Its ignition point, depending on the blend, is between 536° and 853° Fahrenheit. Kerosene has a flash point of 100° Fahrenheit and an ignition point of 410° Fahrenheit. Local fire departments have tables which show ignition points and flash points of most substances.

It is understandable then, that fuels do not need to be touched by flame to begin burning. They simply need to be heated above their ignition points. It is for this reason that heat,

not flame, is the greatest cause of fire spread. Heat can be transferred from one place to another by convection, conduction, or radiation.

Convection occurs when heat is transferred by a circulating medium like air or water. Heat conducted by circulating air is the most common method of fire spread.

Conduction transfers heat by contact. Often, heat from a fire in one room is conducted throughout the structure by pipes or electrical conduit. If combustible material in another room is in contact with the pipe, it can become heated above its ignition point and start a second fire. Metallic objects are the most frequent conductors of heat. Sometimes, though, even brick walls can conduct enough heat to cause a second fire.

Radiation transfers heat in the form of energy waves through space. Heat radiates through any transparent medium like air, glass, or even water. No physical contact is needed. This is how the sun's heat is transferred through the vacuum of space to the earth. Often, a fire in one building radiates enough heat to start a fire in another building, even through a curtain of water sprayed between the buildings by the fire department.

## BEHAVIOR

Fires behave according to well-defined principles of burning. Fires produce heat, flame, smoke, and gases. These combustion by-products may or may not be readily seen. Flame includes both open flame and smoldering glow. Smoke is composed of very fine solid particles and condensed vapors. The composition of fire gases emitted by the burning materials depends on the chemical makeup of the burning material, the amount of oxygen available during burning, and the temperature of the fire. Most fire gases are highly toxic. They are the biggest cause of fire deaths. The biggest single killer is carbon monoxide—not because it is the most toxic, but because it is the most abundant. When breathed in quantity, carbon monoxide causes unconsciousness and, eventually, death. At less than lethal concentrations, it causes disorientation and confusion, subjecting victims to other hazards present

in the fire. The second most dangerous gas produced by a fire is carbon dioxide. While not toxic in itself, a 2 percent increase in carbon dioxide in the air causes a 100 percent increase in a human's breathing rate. This doubles a victim's intake of other toxic gases.

Fire burns up and out. It leaves a V-shaped char pattern on walls and vertical structures. A fire which is hot and fast at the point of origin will leave a sharp V pattern. A slow fire will produce a shallow V. If fire meets an obstruction, such as a ceiling, it will burn across the obstruction looking for a place to go up.

Fire travels with air currents. It never travels into the wind unless the entire fire load—the combustible material or fuel in an area—is on the windward side of the fire. If this happens, the fire slowly eats into the fire load as its tendency to follow the wind is overcome by its attraction for fuel.

Fire seeks oxygen. Because fire consumes great amounts of oxygen, it is always drawn toward new sources of oxygen when burning occurs indoors. It is not unusual to see a char pattern going up a wall to the ceiling and across the ceiling toward an open window. It is also common to find deeper charring and evidence of higher heat on window frames and doorways.

These principles of burning account for most of the fire and char patterns you see

during and after a fire. But sometimes there are unusual patterns that are the result of flashover or backdraft, natural conditions which only occur during fires when conditions are right.

Flashover occurs as heat from a fire in one room causes objects in another room to heat rather uniformly. As the air becomes hotter and hotter, so do all of the objects. Because all of the objects are heated to about the same degree, they are all close to their ignition point. As the first object to reach ignition point bursts into flames, the flames "flash over" the entire room. In an instant every object in the room is burning. The big tipoff to a flashover fire is that burning is only on the top surface of items in the room.

Backdrafts occur when a building burns with all doors and windows closed and the fire uses up all of the available oxygen. It then turns into a slow smoldering fire, generating huge amounts of superheated carbon monoxide gas. The hot gases rise to the top of the room and stay there. Because the carbon monoxide is a flammable gas and it is heated above its ignition point, it only needs more oxygen to burst into flames. Oxygen entering around cracks in doors and windows keeps the fire smoldering. This produces more and more super-heated carbon monoxide. Then, when a door is opened or a window melts out, the intruding oxygen combines with the super-heated carbon monoxide, causing an explosive fire.

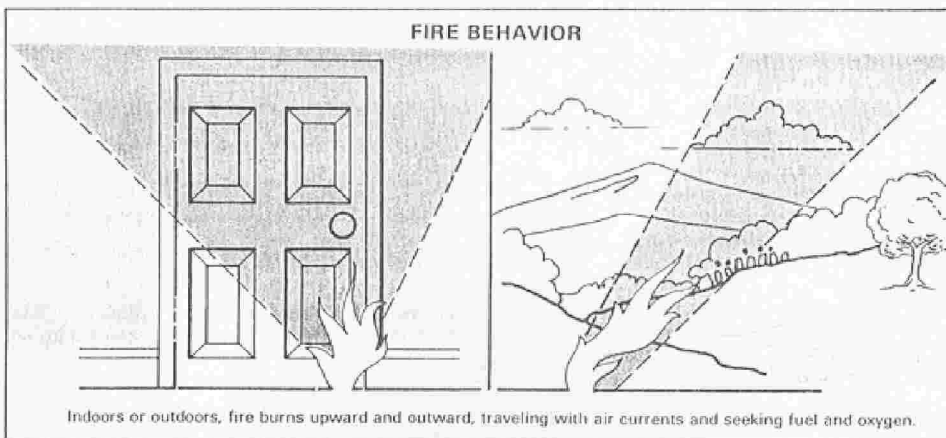

Windows will blow out, and the explosion may be strong enough to damage the structure of the building. Damage caused by a backdraft may look similar to that caused by a low explosive. But a backdraft produces an unusual char pattern. Most of the burn damage will be at the extreme top of the room. There will also be a rather sharp line of demarcation at the bottom of the char pattern on the wall. As with a flashover, no accelerant residue is present.

When wood burns, it chars a pattern of cracks which looks like the scales on an alligator's back. The scales will be the smallest and the cracks the deepest where the fire has been burning the longest or the hottest. Most wood in structures char at the rate of 1 inch in depth per 40 to 45 minutes of burning at 1400° to 1600° Fahrenheit — the temperature of most house fires. A room fire chars only the upper one-half to two-thirds of

the room. Ceiling damage in a normal structural fire is usually at least five times the floor damage. Sometimes a char pattern has a sharp line of demarcation on one side. This indicates that the fire quit spreading in that direction when a draft entered and blew it back.

When glass is exposed to fire it begins to melt at about 1200° Fahrenheit. It becomes runny at about 1600° Fahrenheit. You can learn much about a fire from the glass at the scene. Remember, though, to examine all of the glass and not jump to conclusions from the appearance of just one piece. As a general rule, glass that contains many cracks indicates a rapid heat buildup. Glass that is heavily stained indicates a slow, smoky fire.

Bright metals, like the chromium on toasters, turn colors when heated. These colors may remain after the fire and indicate the temperature of the fire at that location.

## FIRE INVESTIGATION

To investigate a fire you must find out five things: time, temperature, point of origin of the fire, fuel, and ignition source. You must learn how long the fire burned before it was brought under control and assess the amount of damage compared to the time involved. A great deal of damage in a relatively short time should tip you to the possibility of accelerants, multiple fire sets, or a deliberately arranged draft. You must learn the degree of heat in various areas during the fire. The amount of heat given off by a fire is governed by the fire in that area. Indicators of extremely high heat in areas with little fire load may indicate that an accelerant was present. You need to *discover* the point where the fire started. It is here you will find the cause. If you cannot find out where the fire started, you will not find out why it started. You must learn what material first ignited. Would this material be found naturally at the point of origin? If not, why was it there? And you must learn what caused the fuel to ignite. Was the heat source natural to this area? If not, why was it there?

### RESPONDING TO THE SCENE

When you are notified of a fire, note the weather conditions. Pay special attention to

wind direction and speed. They may change rapidly. Note if it is hot or cold. Note if the sun is shining or if it is cloudy or raining. Sunlight focused through glass has been known to start fires. Arsonists may use ignition devices triggered by moisture to enable them to establish alibis for the time of the fire.

When you arrive, do not attempt to enter the burning building. Fire department personnel are trained to fight fires and are properly equipped to do so. You are not. In the unlikely event you arrive at the scene before the fire department, enter the burning building *only* to save a human life. If you must enter, take several deep breaths before entering the fire area. While inside, hold your breath for as long as possible. But do not wait so long that you must take in a whole lung full of air at once. You might inhale dangerous fumes. Keep low, as the air will be better and cooler near the floor. *Do not ever* enter a closed, burning building if the smoke is "dirty" looking and the building creaks and groans. If you even open a door under these circumstances, you will cause a backdraft explosion.

Note precisely the time you arrive at the scene. Then quickly note whether the fire is

burning slow or fast. If the fire is burning fast, is this consistent with the type of fire load present in the building? If not, suspect the use of an accelerant. Note the color of the smoke coming from the fire. This is very important at the beginning of a fire, as it can indicate what material burned first. If you did not see the initial smoke yourself, try to find witnesses who did.

Wood smoke is usually gray to brown. At times, though, black may show where the air supply is poor or the wood is green. It is highly unlikely that a dry wood fire will show much black smoke. White clouds appearing before fire fighting operations begin indicate moist substances are burning. Reddish brown or yellow smoke indicates burning of products having a nitrocellulose base. The presence of reddish brown or yellow smoke where materials of this type are not usually found may indicate such a substance was used as an accelerant. Grayish smoke is produced by loosely packed substances, such as straw and hay, that give off flying soot and ash. Oil, gasoline, creosote, tar, paint, and similar organic materials with a petroleum base usually burn with a black smoke. This is of particular importance in arson, because such materials are commonly used to start fires. Colors of flame and smoke for substances are contained in reference material available at your fire department.

Note the location and the extent of burning. Is the fire only in one part of the structure, or is the whole building involved? Is there only one fire, or does there appear to be two or more separate fires?

Note the condition of the exterior of the building. Especially note damage to doors and the positions of doors. Are they open? Closed? Locked? Note the condition of all windows. Are they opened? Closed? Broken? Melted? Clear? Smoke blackened? Note damage to the structure which might have been caused by an explosion. Note if and where the fire burned through the side or the roof.

Note the color of the flames. If you can, take color photos to document flame color, size, and location. Take plenty of photos throughout this phase of your investigation.

Different substances burn with different colored flames. The color of the flames you observe can later be compared with the fuel that should have been there. This will indicate if foreign material was present. Pay close attention to the relative brightness or lightness of the flames. Generally, flames are the lightest where the fire is burning the hottest. The fire should be burning the hottest where the fire load is heaviest. A large, hot fire where there is little fire load may involve an accelerant. Also note the direction of flying sparks from the fire. Sometimes an arsonist sets another fire near a large, ongoing fire. He will then try to claim his fire started from flying sparks.

While the firemen are fighting the fire, carefully check the area outside the building. Look for footprints and tire tracks which may have been left by an arsonist. If you find such evidence, preserve it by covering it with a garbage can lid, box, tarp, or similar object. If you do not, fire fighters are likely to obliterate it while fighting the fire. And look for tools that could have been used to force entry into the building.

Examine the area carefully for traces of flammable accelerants. Especially note any such traces which appear to lead to the fire area. Look for gas cans or other containers that could transport liquid accelerants. Often arsonists abandon these items at the scene. Sometimes ignition devices like match books or cigarette lighters are dropped by arsonists in their haste. If you spot them, note their positions. Photograph them in place, if you can, before seizing them for evidence. Carefully preserve them for fingerprint comparisons. Place them in the trunk of your car or wherever they will be accessible only to you.

Note odors at the fire scene. Odor is another way to identify burning substances. Ammonia is sometimes used to keep firemen away from the fire or to offset the smell of gasoline. Gunpowder, gasoline, rubber, alcohol, manufactured gas, linseed oil, turpentine, paint thinners, and lacquers have distinctive odors. Feathers, wood, and hair give off a sulfurous odor. Vegetable materials may produce acid or aromatic odors. You may want to become familiar with



the odors of various flammable materials and chemicals so you can identify them when you need to do so. Be careful, however, not to inhale toxic fire gases or superheated air in your attempt to detect odors.

### OBSERVING THE SPECTATORS

Always have the military police identify everyone at a fire scene. This is vital. You may later have to interview all of these witnesses. Most of the time the arsonist is among the spectators at a structural arson fire. Jot down license plate numbers and descriptions of vehicles in the area. If you find vehicles that are not normally in the area, check to learn why they were there. Photograph everyone in the crowd. You can use these photos later to tell whether or not a certain person was there. You can also use them to compare faces with those seen at other suspect fires. Especially note anyone who is overly interested in the fire or who asks questions about the fire's cause. And look for people who seem out of place, like persons fully-dressed at a late night fire.

Identify anyone attempting to leave the scene. If you see a juvenile leaving a fire scene, check him closely. Most juveniles with nothing to hide will stay to watch. Finally, look for anyone who seems to get personal satisfaction from the fire. Compulsive firesetters enjoy flames and excitement. They may give themselves away at the scene by their unusual behavior.

Most fire departments are equipped with an instrument called a "sniffer." It detects hydrocarbon vapors left by flammable accelerants. Ask the fire marshal to go through the crowd with his "sniffer." It will react to anyone with hydrocarbon vapors on their persons.

If the fire occurs in government quarters, listen to the conversation of bystanders, neighbors, and witnesses. Especially note statements like these: "People who live here were having a lot of trouble." "This family has a child they're having trouble with." "Their damn kid is always playing with matches." "I heard the man say that he's been having a lot of financial trouble." "It wasn't 10 minutes ago that I saw them drive away in their car."

### EXAMINING THE CRIME SCENE

Examine the crime scene with the fire marshal. As always, you must see that the crime scene is protected. But because fire scenes are especially likely to be destroyed, you must make special efforts at a fire scene. Most of the evidence is fragile or perishable. The persons most destructive to your scene will be firemen. But once the fire is put out, their responsibility stops until the fire cause is found. The cleanup, known as the overhaul, need not be immediate. Try to arrange with the fire fighters that in cases where arson is suspected, overhaul will not start until you have finished your examination.

Entry into even a fire-damaged building may involve Fourth Amendment considerations. The determination of the source and cause of a fire is normally the responsibility of the fire marshal. His entry during the firefighting operation, or immediately after the fire is extinguished, to locate the source and determine the cause is a valid administrative entry. You may accompany him on such entries to examine and take steps to preserve evidence. But once evidence has been discovered which indicates the fire was arson, you must obtain a search authorization before extending your investigation to other parts of the building. And if such information is obtained, either from fire fighters or from your investigation, before your entry into the building, then you must obtain a search authorization before your initial entry.

### ASSUMING RESPONSIBILITY

Assume responsibility for the investigation when the fire marshal or fire chief tells you that arson is possible. Although much evidence may be destroyed, you can usually find some indication of its presence through scientific techniques. The general principles for examining debris from fire vary with the type of fire and the extent of damage. If all combustible material is destroyed, there may still be quite a bit of noncombustible evidence that remains. Metal tools or objects may have been used to enter or to construct an ignition device. The objects may have been brought in by the

arsonist moved or modified by him. Fortunately, fires in which all combustible material is destroyed are rare on military installations. Fires are most often extinguished in their early state. If so, much of the combustible material will remain. In these cases, wood, building material, traces of flammable accelerants, and items left by the arsonist may be found.

Sometimes an arson attempt is unsuccessful. An arsonist may arrange a device to ignite a building while he is away, so that he will have an alibi. If the device fails, or is discovered, the fire is prevented. Often the elaborateness of a fire setting device helps solve the crime. Tracing a burnt match is difficult, but tracing a complex timing device can prove relatively easy.

### Take Preliminary Actions

Find out from the fire marshal or fire chief the time and method of alarm and the time the engine companies arrived. Be tactful in your asking. Fire departments are sensitive to criticism about slow responses to fires. Make sure that the fire fighters understand that this is merely to help you investigate the cause of the fire.

Ask what fire fighting techniques and chemicals were used. This is important. The chemists at the crime lab must know this to examine the evidence.

Find out how fire fighters entered the building. What was the condition of the doors and windows. If forced entry was made, who made it and how? Get a full statement later from that person. Ask fire fighters if the owners or occupants of the building were present when the engines arrived. If so, what were they doing? Ask fire fighters if they noted any unnatural fire spread or evidence of arson. Check the condition of fire hydrants in the area at the time of the fire. Arsonists like to sabotage fire hydrants to delay fire fighting.

### Search Fire Scene

Search the fire scene from the area of least damage to that of most damage. That is, your search of the fire scene should begin at the outside and move inward. The perimeter of a

crime scene is always the hardest area to secure. Because it is the most fragile part of the scene in which to preserve evidence, it should be done first. And if the point of origin is not obvious, it can be found more easily this way.

Sometimes a fire starts in a piece of furniture that is thrown out of the building during fire fighting. Examine items like these first. They may show remains of ignition devices or traces of accelerants that will be lost or destroyed if they are not found immediately.

Examine carefully any damage in a structural fire that cannot be explained by the principles of burning. If the damage is not explainable as a backdraft or flashover, submit the material for laboratory analysis. Unusual conditions may cause unusual but perfectly natural char patterns. However, examine all such patterns for evidence of arson.

Look at and note the condition of alarm devices. If they were working and did not go off, why not? If they were not working, why weren't they?

Inside the building watch for misarranged, scattered, piled up, or missing furniture and other contents. Note open doors on heaters. Note empty rooms or empty closets. Look for pictures missing from the walls and missing appliances like stoves, refrigerators, or TVs. Notice peeled wallpaper and old, ragged furnishings that may be replacements.

If a fire occurs in a supply room or warehouse, pay particular attention to the debris left from the fire. Was the kind and amount of debris that which would have been left if all the reported items were involved? Was an inventory due? Check the physical size of the reportedly destroyed items against the capacity of the facility. You may find the total cubic feet of the reported material is greater than the capacity of the storage area.

### Find Point of Origin

You must find the fire's point of origin. If evidence of arson exists, you will find it here. If the fire was accidental, you will prove it here. Examine the char pattern. The cracks

in the alligator char are deepest and the scales are smallest at or near the point of origin.

Examine beams on the ceiling. The corners will char and round off away from the point of origin and direction of fire travel. Examine the most heavily damaged ceiling area. The fire is usually hottest and climbs most rapidly at the point of origin. Any place where the ceiling has dropped out or has burned through is likely to be over a point of origin.

Examine light bulbs and bottles found at the scene. If heated enough, glass objects melt. The side of an object closest to the point of origin gets hot faster than the other side. The object then tends to tilt and point towards the point of origin. Examine the window glass remaining in the area. The glass showing the fastest heat buildup is likely to have been closest to the point of origin.

### ELIMINATING NATURAL CAUSES

Once you locate the point of origin, you find the cause of the fire. To do this, you must learn the source of the heat and the kind of fuel that fed the fire. Then attempt to reconstruct the event that combined them. The source of the heat may be chemical, electrical, or mechanical. Then consider if the event was accidental or incendiary.

All fires are presumed accidental until proven otherwise. To determine a fire as the work of an arsonist, you must first eliminate natural causes. Electrical fires often are caused naturally. So are fires started by heating systems. Fires from cigarette smoking, children playing with matches, and other possibilities must all be checked out before a fire can be declared to be incendiary. You must prove that a fire was incendiary before you can even begin thinking about a suspect. Indeed, even if you obtain a confession, the case may never go to

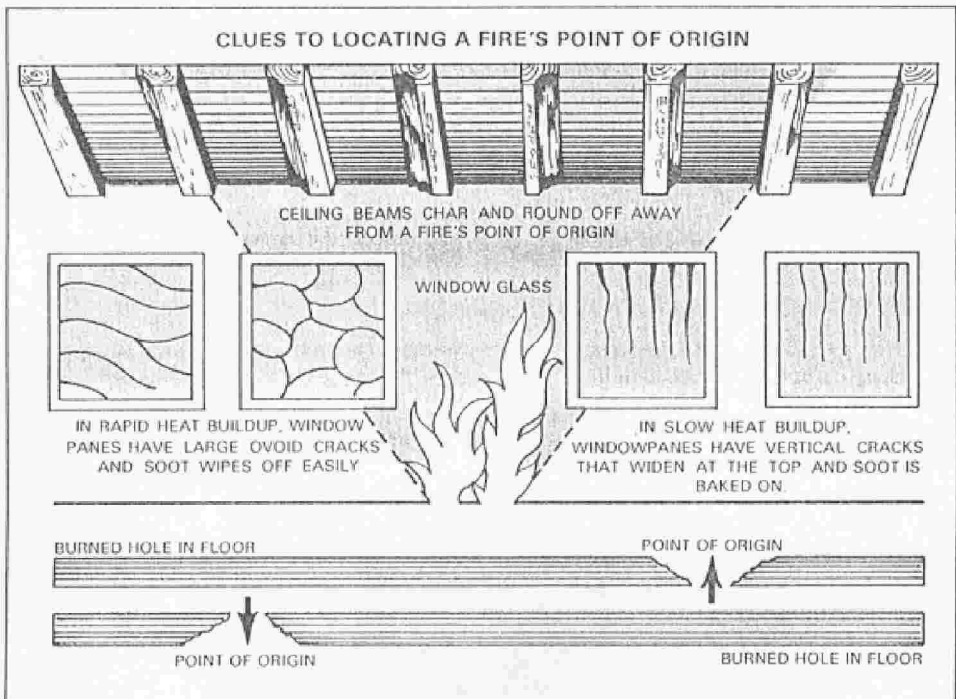

court if you cannot present evidence to corroborate the details in the confession.

### ESTABLISHING PROOF OF INCENDIARY FIRE

You should suspect a fire to be incendiary if you find circumstantial evidence of special preparation for the fire. If you can show that a fire started in two or more places and that the fires are totally unconnected, you can establish proof of an incendiary fire. You need not prove for sure what started the fire. You must prove, however, that one fire did not result from another fire. The burning material may have dropped or blown from another location. The heat could have been transferred from another fire. Or fire, shorting out electrical lines and creating overloads in other parts of the system, can cause fires elsewhere.

#### Look for Ignition Devices, Accelerants, and Trailers

Linking ignition devices, accelerants, and "trailers," at the point of origin are considered proof that a fire was incendiary.

The remains of ignition devices at the point of origin are the most positive means of establishing arson. Make a careful search for suspicious articles and devices like fuses, clocks, cans, candles, bottles, wires, and dry cell batteries that may have been used to ignite or accelerate the fire.

If an explosion has occurred, recognizing the nature of the explosive material can give you an indication of the types of igniting devices you should look for. If the explosive material is lighter than air, like natural gas, the walls will be blown or bowed outward near the ceiling. Explosions caused by lighter than air explosives and those caused by back-drafts are very much alike. But the explosion that ignites a fire does not leave a charred pattern on the upper part of the room like that caused by a back-draft, a result of an existing fire. If the explosive material is heavier than air, like liquid fuel, the walls will be blown out near the floor. If the exploding material is a solid-like smokeless gunpowder, it produces a "pushing" effect but leaves gaps in its force path wherever it meets heavy, fixed objects like upright posts or beams. If it is a solid

material like dynamite, it creates a localized shattering effect at the center of the blast.

The most common igniter is a match. Sometimes a pan containing gasoline is left on a hot plate. Chemical ignition devices can be made from many combinations of household chemicals. One of the most common is a swimming pool chlorinating compound. The kinds of ignition devices are limited only by an arsonist's imagination. Carefully examine *anything* unusual at the point of origin. Submit debris from the point of origin of all suspect fires to the crime lab for analysis.

The presence of flammable accelerants where *none* are ordinarily kept can be considered proof of arson. Use a sniffer to detect hydrocarbon vapors after the fire is put out.

Liquid accelerants leave evidence of low burn. That is, they show burning on the floor of the structure. A normal fire chars only the upper portion of a room. Floor damage in natural fires is usually limited to about 20 percent of the ceiling damage. Low burn, shown by complete charring of large areas of the floor or the baseboards, is not natural.

Nor is fire burning downward natural. Fire burning downward is a prime indicator of use of a flammable accelerant. Patterns burned in wood floors or holes in a floor may show that an accelerant was used. Burning in the cracks of the floors, under carpets, along the bottoms of doors, or in back of baseboards also indicate use of accelerants. Heavy deep char, out of proportion to the damage in other areas, may indicate the presence of accelerants. So may burning on the underside of furniture. But be aware that some foam padding in furniture melts as it burns. It makes a low burn pattern under and around the item just like flammable liquid does. Lab analysis may be needed to tell the difference.

We tend to think of accelerants as liquids like gasoline. But paper, cloth, packing material, or trash may have been used. If so, it may have been brought in by the arsonist. It may leave traces of fibers, glass, hair, soil, metal, and the like that can be connected with the arsonist.

Trailers are trails of flammable liquid or solid material such as newspapers, clothing, rope, or waxed paper used to lead a fire from one part of a structure to another. Since there is usually only minor floor damage from fire, the marks of a trailer may be clearly visible on the floor.

### Check for Special Preparations for the Fire

Sometimes arsonists make special preparations. They move or stack items to increase the fire load. They may empty fire extinguishers in the building and nearby buildings. They may block doors or cut holes in the floor to increase the draft or to hinder firemen. Often they break windows or leave them open to increase the draft. Sometimes they substitute cheap broken items for the contents of the building.

Arsonists may pull curtains that are normally kept open. Or they may place objects in front of windows to block the view into a building. They also may disconnect or muffle alarms and deactivate sprinkler systems.

Arsonists often remove valuable documents and expensive items like color TVs, stereos, and guns. Other items removed from residences may include expensive clothes and jewelry, family photographs, hobby or sports equipment, and tools.

Other circumstantial evidence supporting a belief of arson may be burns on occupants who are absent when the fire department arrives. Immediately check the local hospitals for burn admissions or treatment after any major fire. And be sure to note burned or unburned newspapers at the point of origin, especially out-of-town newspapers. A professional arsonist often uses his newspaper when he makes his set.

### PROCESSING THE CRIME SCENE

Once you have located the point of origin and identified evidence, you must document and collect the evidence. Because fire scenes have usually been greatly disturbed by the fire fighting, unless a death is involved, you need not make as detailed a sketch as you do for other crime scenes. It is important,

though, to have a general sketch of the scene showing the position of various items of furniture in the room. And pay particular attention to the area of the point of origin and any evidence you find.

What you *absolutely* do need is photographic evidence of the fire scene. Photographing a fire scene is one of the most challenging things that you may be called upon to do. It is relatively simple, though, if a few simple guidelines are followed. First of all, whether or not flash is used, obtain a correct guideline for exposure by focusing into the darkest, blackest portion of the charred material. Set the camera at whatever exposure the meter indicates. If you are using flash, set the camera at the proper f-stop according to the guide number or distance scale on the flash unit. Then take one picture at this exposure. The lens should then be opened up two f-stops. Take a second picture of the same area. Finally, the lens should be opened up two more f-stops. Take a third picture at this exposure. Thus, you obtain three photographs of every blackened or charred item you wish to record. One should be taken at what is normally the correct exposure, one overexposed by two f-stops, and a third overexposed by four f-stops. Usually the second and sometimes the third exposure will be the correct exposure for your purposes.

Process the arson scene, keeping in mind the unique and fragile nature of arson evidence. Make detailed notes on the fire's cause and the location of the evidence. Detailed, accurate notes are vital to your presentation of evidence. Pay close attention, and record everything the fire marshal says and points out to you. This will, of course, help you in writing the case. Moreover, the fire marshal can use your notes to refresh his memory when he is called upon to testify months or even years later.

The best place to look for evidence of arson is on the floor of the scene. Be sure that you have enough evidence. The burnt material on the floor of that building is not considered precious material. You do not have to sign a hand receipt for it. The more evidence you collect, within reason, the better the chances of the crime lab finding what caused the fire; if accelerants were used; and if so, what kind.

Collect evidence from the point of origin. And collect it from any area where the sniffer or other indicators alert you to the presence of flammable accelerants. Be sure to collect the ends of boards that might have been exposed to accelerants. Flammable liquids soak deep into the end grains of the wood. They are likely to remain in detectable quantities. Also, collect odd-colored ashes or soot, unusual formations of clinkers, and impregnated materials. Examination of ash, when possible, is important, particularly in instances of small fires such as those in a fireplace, furnace, incinerator, or bonfire. Fragments should be collected very carefully, placed in a container large enough not to exert strain or pressure, and taken to the laboratory with the minimum of disturbance. A fragment may be sprayed with a thin lacquer to strengthen it enough to handle. But if the fragment is to be checked for accelerants, do not spray it.

After you have collected the evidence, you must take steps to preserve it. Use vapor-tight containers to package volatile substances. New, unlined metal paint cans with friction-top lids are best for arson debris. You can also package debris for which no accelerant odor is apparent in heat-sealed kapok bags. Do not use ordinary plastic or paper bags or boxes for arson debris. Volatile substances can diffuse through the plastic, then accelerants are lost and/or other exhibits are contaminated. Unlined metal paint cans are available from the post engineer's paint shop or through government supply channels.

### IDENTIFYING SUSPECTS

After you have processed the evidence from the crime scene, you are ready to identify suspects and begin the follow-up investigation. To find the arsonist, first analyze your target. Ask yourself these questions. Why was this target chosen? Why was the fire set? Why was it set at this particular time?

Then look for persons who had motive, means, and opportunity to set the fire. The motive to commit arson may be to fill emotional or economic needs, or it may be to divert attention from another activity or crime. The means to commit arson may be

available to a suspect at his place of work or from his hobbies. And a suspect's opportunity may be a matter of being at the fire in person or being able to hire someone to do the job.

### Check for Motives

Emotional motives account for most structural arson fires on a military reservation. The motive most responsible for structural arson is spite/vengeance. The arsonist, feeling wronged, wants to cause injury or hardship to a person or to damage government property because it represents an authority.

Sometimes an arsonist is dissatisfied with substandard living or working conditions. He sets fires to require repair or replacement of substandard facilities. Sometimes fires are set as wanton acts of destruction. Juveniles indulging in vandalism are likely to cause such fires. Sometimes fires are set so an arsonist can make himself a hero by discovering or putting out the fire. For this reason, the person who reports a fire is always a suspect. These vanity fires are not often large fires. They are commonly set in trash or inconsequential material. Sometimes, when there is a sequence of unexplained fires, these fires are the work of a compulsive fire setter. Compulsive fire setters suffer from a psychological disorder called pyromania that exhibits itself in an uncontrollable impulse to start fires.

Some fires are set to divert attention. They may be set to conceal occupational wrongdoing like white-collar crime, as well as crimes of a more serious nature. Unit supply personnel who are accountable for property that they lose through carelessness or sloppy procedures sometimes set fires to cover shortages. Agitators set fires as a means of causing or furthering a civil disturbance. Saboteurs set fires to create diversions to allow them to examine classified material or destroy vital military equipment. Embezzlers manipulating cash flow or stock control documents may set fires to destroy incriminating documents before inspections, audits, or crime surveys.

Economic motives account for fewer arson fires than emotional motives, but they cause more property damage because they are

usually set to destroy high value property. Most, but not all, economic motives involve insurance coverage. Since government property is not insured, this type of fire is seldom seen on a military reservation. The exception to this is an incendiary fire of a privately-owned vehicle. Most vehicle incendiary fires are set for insurance motives. Sometimes business competitors set fires to eliminate their competition. These fires may sometimes occur on a military installation where insured stocks of high fashion or similar items are stored by concessionaires. Owners or occupants of buildings sometimes attempt to pass off accidental fires as arson. They may fear higher insurance premiums, embarrassment, or that they may have to pay the cost of putting the fire out. They may also lie to protect others. This is typical of parents protecting juveniles.

Burglars and thieves sometimes set fires to cover up signs of forced entry or missing

items. Thieves may set fires to cover the loss of property or to create enough confusion to allow them to fence the stolen property before it is reported stolen. And fires are sometimes set to cover evidence of homicide in hope that law enforcement officials will believe the victim died in the fire. All deaths involving fire require a thorough autopsy. See Chapter 19.

#### Look for Means and Opportunity

You must try to link the suspect to physical evidence found at the scene. Try to find fingerprints or documents showing that the suspect purchased materials similar to those found in the fire. Of these means, fingerprints are by far the most valuable. They may be found in protected areas. For example, look on the bottom of gas cans or in areas where the fire did not burn. You also must show that the suspect was at the scene when the fire was set, or show his connection with some other person who is believed to have set the fire—that is, with a hired torch.

### ACTION PHASES FOR INVESTIGATING AN ARSON

#### EXAMINE THE FIRE SCENE WITH THE FIRE MARSHAL

- Assess the amount of damage in relation to the length of time the fire has burned.
- Note indicators of extremely high temperature in the presence of a small fireload.
- Locate fire's point of origin.
- Find source of heat and note kind of fuel.
- Note signs of fire behavior not explained by principles of burning.
- Eliminate natural causes.

#### ASSUME RESPONSIBILITY FOR THE INVESTIGATION WHEN ARSON IS POSSIBLE

- Look for evidence of multiple unconnected fires.
- Look for and link ignition devices, accelerants, and "trailers" to the fire's point of origin.
- Look for evidence that valuables have been removed, fuel stockpiles, drafts created to enhance oxygen supply or other special preparations have been made for the fire.
- Establish proof of incendiary fire.

#### PROCESS THE CRIME SCENE; IDENTIFY SUSPECTS; COMPLETE THE INVESTIGATION.



## Guns NOT to Buy for Survival

*by Douglas P. Bell*

What guns NOT to buy for survival is almost-as important as what gun TO buy for survival. Firearms chambered for cartridges that are not common now would not be a good bet for survival use unless you had your own cache of ammunition and reloading supplies. While the .505 Gibbs may be the ultimate big bear, moose and elephant cartridge, if you can't get ammunition, cases or bullets for it NOW, it would not be ideal for survival use in the future.

To be fair, I'm going to divide this article into four parts, what long guns to avoid, pistols to avoid, a break down of "survival gun" books and what cartridges to avoid. The reason for this is that there are a lot of guns out there that are not suitable for survival use due to design, price, caliber or cartridge, or possibly some other consideration. The same is true of several cartridges as well, some are not ballistically balanced, common or are just inferior to others in the same caliber.

First let's get the guns I DO NOT recommend out of the way. I would like to say there may be nothing "wrong" with many of these guns, but that they are either not suitable for survival, at least as far as I am concerned, due to price, availability, or parts supply. If the gun is over priced all you are out is money, which could have put to better use elsewhere.

Availability and parts supply are pretty much self explanatory. If you can't get at them to buy in the first place, or you can't get spare parts, it doesn't matter how great they are, they are worthless for this use, since once they break or wear out, they can't be repaired or replaced.

Guns that fall into the "you've got to be-kidding" class are the "Sten" and "Sten" type copies such as the Encom MK IV and MP-9/MP-45 pistols, Holmes MP-83, Feather AT-9 and AT-22, the federal XC-900/XC-450/XC-220 and Ljutic "space" guns. Also included here in the "you re kidding" group are the FIE Spectre, Steyr AUG, and the Uzi. Like I said, all these guns may work, and work great, but all are designed to be super cheap in construction if not in price! If I'm paying for expensive machining, I want expensive machining!

The Sten, Encom, Holmes, Feather, Federal and Ljutic guns are designed to use simple seamless tubing for the receiver and most other parts as well! Go down and look at what seamless tubing is going for now in the sizes needed, generally about \$5-\$10 a foot retail.

They also use "off the shelf" plastic parts and spot welds or arc welds with no (or very little) polishing or other cosmetics to cover the rough spots. While I don't

mind a weapon that looks a little rough as long as it works, I also don't expect to pay a premium to have it left that way either! With these guns you are paying a premium for the crude "military" looks, not performance.

A good example of this is the Sten, which was mass produced in England in dozens of small one and two man shops for about \$2.00 per finished gun, but one firm is "selling" (Maybe I should say "offering for sale") semi-automatic "Stens" for around \$500 to \$800 each! You can buy real Sten parts kits and receivers blanks and build (check the BATF and local laws first) your very own semi-auto Sten for about \$150 to \$200 each!

The other guns listed, the FIE Spectre, the Uzi and the Steyr A.U.G. were all designed to use state of the art (at the time anyway) tools and designs to be made as cheaply as possible. The Uzi is simply the taking of other designs and combining them together to get a good weapon with as many stampings, spot welds and simple "off the shelf" machine parts as possible. The Steyr A.U.G. uses a plastic receiver/stock, trigger and hammer group, plus just about plastic everything else except the barrel. They are all WAY overpriced as far as material and workmanship is concerned.

The M1 Garand is my all-time favorite military battle rifle, and I'm not anyone in this. There is even a Garand Collector's Assn. (POB 181, Richmond, KY 48475). The Garand was THE battle rifle of WW II as well, but like Ethiopia, which had the finest light horse cavalry which kicked the Italians out of Africa in WW I but got wiped out in their first charge in WW II, this isn't 40 years ago. Times have changed and so has weapons design.

The M1 Garand is outmoded now as far as most military planners are concerned. This is not to say it isn't one of the finest semiautomatic .30-06 battle rifles going, but this is due more to a lack of semi-auto .30-06's than the design, although the M1 can hold it's own in any company. However the point is, survivalists are not military planners either, and any one who plans to fight constantly is lost from the start as the point is to survive.

The M1 Garand needs M2 Ball (PMC "generic" is M2, as is all U.S. Mil. from the 1930's on) ammunition to function properly and regular sporting ammunition will normally over function the action and bend the operating rod or wear out the gun in short order. Other problems include the large opening behind the bolt, the same problem the M-14, M1 Carbine and Mini-14 have. The bolt opening always dirt and water in to the back of the action which could jam the weapon. The Garand also needs eight round en-bloc clips to work and while these are getting harder to find they are still readily available on the surplus market.

If you can work around the limitations of the Garand, it is a wonderful weapon and there is nothing finer. If you can't, then pass the Garand up and get something else, possibly a M-14.

Another U.S. Military weapon that I wouldn't recommend for survival is the M1 Carbine or commercial copies. While the gun is short, light and handy, it is chambered for what amounts to a pistol cartridge, and in fact was designed to replace the Colt .45 Auto. While the gun itself is readily available and quite inexpensive right now, the ammunition costs almost as much as the .30-06 ammunition on the market. For more on this, read my reviews of the M1 Carbine.

As to the other military weapons, especially bolt actions, some are good and some are garbage. If you choose a military bolt action, be sure you can get ammunition and spare parts for it, and buy up a couple of truckloads of ammo NOW so you will have it later. Most of the odd-ball foreign ammo is surplus and supplies could dry up at any time, or the anti-gunners could ban it's sale.

The Mosin-Nagant rifles are very, accurate and cheap right now as is the ammunition for it. Of the Mauser bolt standard chamberings (7mm Mauser, 8mm Mauser, .30-06, 7.65x54) and get lots of ammunition for them.

Now we are going to talk about "survival handguns" that aren't all that great for survival. First of all, just what is a survival handgun? It is a tool, nothing more. It is not, by itself, a force for evil or good. It is not as good for hunting as a rifle or shotgun, nor is it as powerful. It is also the court of last resort. It is the last ditch weapon before you start throwing stones. It has to be light enough to carry, small enough to conceal if need be, rugged enough to withstand a considerable amount of use and abuse and powerful enough to stop, not just kill, an attacker. And that my friends is a pretty tall order.

Now that you've read that last paragraph, go back and read it again, it is highly germane to the rest of this article that you understand what it said. A handgun is just a tool, nothing more. Choose the wrong tool and you can't do what you want. After all, you don't use drills to pound nails, so don't choose any gun and expect to do it all, from bears to mice and have no recoil. The handgun you choose must be able to do what you want, but it can't "do it all", at least not by itself and there probably never will be one that can.

Mel Tappan in his book "Survival Guns" divides guns up in to two groups, "working" guns and "fighting" guns. This is OK if you have an unlimited supply of cash to buy with, but for most of us, a working gun and fighting gun are whatever we happen to have at hand at the time. So it behooves you to choose your weapons carefully.

I said the handgun was the court of last resort and I meant it. A handgun is the LAST weapon you want to be using to fight or hunt with. However it is also the only weapon you will probably have on you when you need a weapon and need it NOW. Therefore, it must be small enough to carry on your person at all times, and that means both weight and size.

The gun must also be chambered for a cartridge powerful enough to stop your attacker NOW, not later after you are dead! It must be sturdy enough to withstand considerable use and abuse. After all you are going to need to actually shoot the gun to learn how to shoot and become proficient in it's use. This generally means it should not have zinc, aluminum, or other lightweight frames that will wear quickly, although some of the hard chrome finishes are harder than the underlying metal, and will wear well.

All the expected criterion are opposites also! To be light enough to carry it would need a light recoiling caliber or it will tear your arm off each time you shoot it. To be large enough to be controllable, sturdy and shoot a reasonable cartridge it needs to be large and/or heavy. So you can see the needed handgun is a series of trade offs, power for size, weight for power, strength for size, the trades go on.

What guns you need however isn't the point of this article. What you don't need is. You remember I talked about the "Sten" type firearms like the Holmes, Encom Spectre, Intratec TEC-9 and TEC-22, etc. and said they were designed for inexpensive manufacture but were, in my opinion, over priced? Well they have all equally fatal flaw in their size. Some of these guns are well over a foot long, and with the clip installed, over a foot high! Some weigh as much as a Ruger Mini-14 but only shoot low powered pistol ammunition! Not a good trade!

Now let's look at the two "survival weapons" books: Mel Tappan's *Survival Guns* and Duncan Long's *Firearms for Survival* and see what unsuitable guns are recommended.

Let's start with "Survival Guns" and see what guns Mel recommended. First, there is the S&W Model 29, the gun of "Dirty Harry" fame. Well, this gun is certainly powerful enough for our use. The gun is chambered for the .44 Magnum, it's very power works against it. This gun has a very delicate lock-work, so unless you are a pistol-smith, and enjoy retiming your guns every few rounds, this one should be passed by. Also heavy, bulky and expensive.

The Python is Colt's top of the line revolver and a beautiful pistol, but many other guns less expensive are available and with a little work can match the function, if not the fit and finish, of the big bolt. If you have money to turn and want a nice .357 Magnum I really can't think

of anything to say against it though.

As far as "pocket pistol's" are concerned, the Charter Arms (now "Charco") guns are "good", but they aren't "real good". Most Charter Arms guns are light weight "light duty" pistols and wear out or break down fairly quickly. If you plan to carry the gun a lot but shoot it very little, this might be an acceptable choice. If you want one get it now, as well as a goodly supply of parts. You may not be able to later.

Now on to Duncan Long's "Firearms for Survival", and the third chapter ".22 and .45 ACP Pistols". The first line of the second paragraph tells it all, "The .22 rimfire shells and the .25 ACP are poor for self-defense purposes". That pretty much sums it up, the .22 and .25 ACP are piss-poor stoppers, although a .22 pistol would be all but indispensable for pest control and practice.

The .25 ACP, due to it's high priced ammunition, tiny, light bullets and tiny, light weight "light duty" pistols are also not viable survival weapons. Like I said before, the point is to survive the fight, which means stopping your opponent NOW, not having them die three days after they have killed you and your family. Yes. I know, .22's and .25's have dropped people in their tracks and .22's have killed elephants, but let's face it, both cases were flukes.

Another thing I don't like about the book is that all the gun had to do to be included was have the manufacturer send a photo, and Duncan would say nothing bad about any of them. Survival is not the place for low quality trash or "cutsie" little toy like guns. If you've never heard of the gun and it looks like low quality garbage there usually is a reason for it.

As far as the other guns are concerned, the Desert Eagle semi-auto pistols, which Duncan refers to as "stockless rifles" are large, heavy and VERY expensive. The Ruger P-85 has an aluminum frame that may wear out rather quickly and when it does you are out a pistol. Also the repeated problems that Ruger has had since introducing the pistol, including one recall, has not boded well for it for survival use. As to the other hand-guns in the book, I stand by what I said earlier, if you haven't heard of it or it looks like trash there's a reason for it and you shouldn't risk buying it for survival purposes.

Currently there are only two books that can be even remotely referred to as "survival weapons" books Mel Tappan's classic "Survival Gun" (Janus Press), and "Firearms For Survival" by Duncan Long (Paladin). For more on either of these two books plus a book review of their other works, I would recommend you read the book reviews I did on these books.

First let's look at the weapons that Mel Tappan talks about in his classic book "Survival Guns". "Survival Guns" for those who don't know is mandatory reading for

anyone who hopes to make a go of it after "the day" and wants to use firearms to survive. For more on the individual weapons listed in Mel's book, read the first two parts of this series.

Actually there isn't really much to disagree with if you have an unlimited supply of cash to buy with, and understand that "Survival Guns" was published in 1970, and is now badly dated; many of the firearms are no longer made and some of the firms are out of business as well. This isn't intended as a put down of 'Survival Guns' as ANY survival gun book would be dated in just a few years and badly dated in ten and Mel, who died in November of 1980, would most likely updated the book by now.

First let's take a look at the batteries Mel set up. The first problem is just too many guns! In the first battery he talks about in the book, he has 44 cartridge guns, two air rifles, and "several single-shot shotguns and inexpensive .32's"! Let's call that 50 cartridge guns (the real number may be considerably higher depending on how many "several" is) for a single couple, and these guns are in at least 15 different chamberings! While all the guns are top of the line weapons, there are just too many of them and in too many different chamberings to be truly practical! Logistics would eat you alive! Just supplying the cleaning kits, spare parts kits, ammunition, holsters, slings, scopes, etc., would overwhelm you in short order!

The second battery is also for a couple, and has 14 weapons in seven to nine chamberings depending on what the shotguns are, and a few of the other non-listed chamberings. The fifth battery (the third and fourth either were not listed by gun or were not designed by Mel) has 13 guns in four calibers, but this is for a Green Beret who is to provide protection for a group. The sixth battery has four guns in three calibers and I agree with Mel that it is not "sufficiently realistic".

Well, that should be enough to show what I want to talk about here: too many guns in too many caliber or cartridges, with too many different makes and models. The first battery has 31 different makes or models of guns in 15 cartridges. The second battery has 11 different makes or models in at least seven cartridges. The fifth battery has nine makes or models, but only four different chamberings! The sixth battery has three guns and three calibers so it '5 not as bad as the others, cartridge to number of guns wise, but as Mel said, it's extremely limited too.

Now let's start breaking that down, what guns and why. First he has an Armalite AR 180 AND a Ruger Mini-14. Why not two of the same model? That way you would need only one spare parts kit, and need to "learn" only one gun. By "learning" I mean where the safety is, how to load, clear jams, etc. Many a G.I. lost his life

fumbling for a safety or clip that wasn't there when switching between the M1 Garand and M1 Carbine.

Also along these same lines, I'm still talking about the first battery here, he has a (Pre-64) Model 70, and a Sako and Husquarna in the same action length. Why not three Model 70's, three Saksos or three Husquarnas? This would, as I said earlier, make learning and parts kits much simpler. Why a Colt Python and a S&W 19? Why not two of either one? Also, why a Savage 99 (an excellent gun and greatly under rated) in both the .308 AND .243? Why add the extra cartridge to the line up? It's going to be hard enough supplying ammunition for all the other guns as it is, why add more? The same pattern is repeated in battery number two, an Armalite AR 180 AND a Ruger Mini-14.

The fifth battery is for a Green Beret, so the person should have had a good idea what they wanted in the first place. Most of the guns are listed as pairs, two Armalite AR 180's, two Colt .45's, etc. Note the limited number of cartridges, just four, and a recommended hideout gun was vetoed as it would have added an extra cartridge to the line up. A wise move!

Now on to the "other" survival gun book, "Firearms for Survival". The best way for me to describe the book is to think of someone sitting down and writing all the makers of firearms listed in the "Gun Digest" and then including all the guns that the manufactures sent photos of. It may not have been that way, but it's a rare photo that isn't marked "courtesy of..." too.

As I said in the other chapters, I do not consider ANY .25 ACP pistol or most cheap, low quality handguns to be a 'survival' weapon. So much for the .22 and .25 ACP chapter.

The .22 rifle chapter continues the theme of low cost, and in some cases, low quality rifles. Mixed in with the "less than suitable" rifles are some really excellent rifles that seem to stand out by comparison, at least in the photos if not the text. Also some of the after market accessories are just about worthless for survival. If you want to look "mean", OK I have no problem with that, just don't confuse looking mean with surviving.

The rest of the chapters (.32 & .380 Autos, 9mm & .45 Autos, Revolvers, Pistol Caliber Carbines, Shotguns, Centerfire Rifles, Special Purpose Guns), aren't too bad, although you must read closely to find out what is really meant. Also there are the usual mistakes, the 311 Savage double barrel DOES NOT have outside hammers, and any good M1 Garand can hold it's own against other battle rifles of it's era and does not give 'less-than-ideal accuracy'.

"Firearms For Survival" is an interesting book, but is nowhere near the book that "Survival Guns" was (and still is for that matter!). I would not recommend spending

\$16.95 (the current list price) for it. If you can borrow a copy that you should read "Firearms for Survival", but if you can't, well you haven't missed anything.

For this article I could simply tell you that this or that cartridge is unsuitable simply by picking up a copy of "Cartridges of the World" or "The Handloader's Manual of Cartridge Conversions", (both excellent books by the way and well worth reading), and listing the cartridges. There probably are some writers who would do this if it occurred to them, but let's go through the two "survival gun" books again and see what they recommend that I don't and why.

Let's start with (what else?), "Survival Guns" by Mel Tappan and see what he recommends for survival use. First he talks about centerfire handgun cartridges so let's start there as well. He starts with the .25 ACP and said 'there is certainly very little use for this cartridge...' but, "if you are really aware of its extreme limitations, you use it at little more than arm's length and are cool enough to shoot for the eye sockets, it may give you a 5% chance of stopping an attack from a single assailant." Well 5% is better than nothing, but if I was so cool, calm and collected enough to do all that, I wouldn't need a .25 ACP either. Pass the .25 ACP on by.

I pretty much agree with his views on the .32 ACP, .32 S&W Long, .380 ACP and .38 S&W so we can keep going. As to the .38 Special, I feel he comes down a little hard, especially for someone who can find a use for the .25 ACP! However I don't recommend getting guns in the .38 Special either, and for the same reasons listed. If you want a .38 Special get a .357 Magnum and shoot .38 Specials in it. That way you have in effect two different handguns: one a mild and easy shooter, and one powerful and hard hitting, just by changing ammo. Also if you can only get one or the other you are still able to use them.

I pretty much agree with him about the 9mm pistol as well. It's a totally inadequate cartridge to bet your life on, being nothing more than a rimless .38 Special. However as just about every police department, highway patrol and the U.S. Military has gone to it, as well as it being about as common as a cartridge as can be found, I would recommend you have a pistol or two around for it. The .357 Magnum is referred to as a "compromise", and is a good "working" cartridge, but not a good "fighting" cartridge. If you like revolvers though, this is the way to go.

Now for the next three cartridges, the .38 Super, the .41 Mag, and the .44 Special. Although Mel doesn't like the .38 Super, and I do, I do agree with him that it isn't a suitable survival cartridge, and neither is the .41 Magnum. The .44 Special is like the .38 Special, you shoot it in the .44 Magnum as a light load. If you already have a .44 Special, it is an excellent cartridge.

As to rifle cartridges that Mel recommends and I don't, let's start with the .243 Winchester. Well at least it isn't the 6mm Remington that one writer recommended! The .243 can be made by necking down .308 brass, but you will need to turn or ream the necks or the brass may be too thick. A nice cartridge, but stick with military issue until you have enough experience to know what you are doing.

The .270 Winchester is a nice cartridge, but one I do NOT recommend for survival. The cartridge uses an odd-ball bore size so you can't pull bullets from other cartridges to use here like you can with .22 or .38 caliber stuff. Also while it is very popular as a sporting caliber, under survival conditions that could change in a hurry.

The .30 caliber stuff, the .30 M1 Carbine, .30-30 Winchester, .308 Winchester (7.62x51 NATO) and .30-06 Springfield are next. I agree pretty much here, the .30 M1 is pretty worthless as a survival cartridge, but as so many guns and so much ammo is stored away, get something to shoot it in, a "shell Shrinker for one of the other cartridges works well here. I agree with all he has to say about the rest as well.

As to the cartridges he WOULD NOT recommend "solely on the basis of their ballistic inefficiency or poor design are the .32 Remington Special, the .300 H&H Magnum, and the .351 Winchester SL (Self Loading), together with all of the obsolete pistol/rifle rounds such as the .38-40, .25-20, .25-35, etc." Sorry Mel, the .300 H&H is one of the MOST ballistically efficient of the big .30's and won the 1000 yard 1935 Wimbledon Match with FACTORY ammo! There is NO ".32 Remington Special", he means either a .32 Remington or a .32 Winchester Special, either or both of which we could easily do without, as well as the .351 SL.

As to the "obsolete" pistol/rifle cartridges the new improved 10mm Auto and .40 S&W are just rimless copies of the old .38-40! The .25-20 and .32-20 are both nice little rounds now coming back, although like I said, stick with military issue until you know what you want. Also along these lines, the .25-35 was NOT a pistol/rifle round, it was a rifle ONLY round, at least before the T/C Contender.

Now on to "Firearms for Survival" and what is included as a "survival" round. First the .25 ACP is OUT, as are the .32 ACP and .380 ACP. I happen to like the .380, but not for long term survival!

About the only time he talks about other cartridges as such is in the lineup of photos, supplied by Federal of course, and he states "a wide range of rifle ammunition is available for survival use." Just because it is available doesn't mean it is suitable! The .22-250, 6mm Remington, .257 Roberts, .25-06, .270 Winchester, 7mm Mauser (unless you have a military arm and LOTS of ammo !),

and 7mm Magnum are cartridges that I would NOT recommend, although they are "available"!

The second photo (listed as "another assortment of rounds useful for many survival needs") includes the 300 Savage (an excellent cartridge in it's own right, but not popular enough for survival use), the 8mm Mauser (see the comments about the 7mm Mauser), "two of the .32 Winchester Special" (actually what is pictured is a .32 Winchester Special and a .35 Remington, pass them both by), and .45-70. The .45-70 is the one "iffy" round here, as there are times when the big cartridge could come in handy, but not enough to be included in a survival battery.

When President Elect Clinton heard we wanted to move to ARKANSAS, he sent us the following:  
APPLICATION TO LIVE IN ARKANSAS

NAME: \_\_\_\_\_

Nickname: \_\_\_\_\_ CB Handle: \_\_\_\_\_

Address (RFD): \_\_\_\_\_

Daddy (if unknown, list 3 suspects): \_\_\_\_\_

NECKSHADE: ( ) Light Red ( ) Medium Red ( ) Dark Red ( ) Other \_\_\_\_\_

TEETH: Number of teeth exposed in full grin \_\_\_\_ upper \_\_\_\_ lower

TRUCKS: Make of Pickup \_\_\_\_\_ Size of Tires \_\_\_\_\_

HOUNDS: \_\_\_\_ Type: ( ) Bull Terrier ( ) Beagle ( ) Black&Tan ( ) Other \_\_\_\_\_

CAR: How many cars in front yard? \_\_\_\_ How many on blocks? \_\_\_\_

OTHER: How many kitchen appliances on front porch? \_\_\_\_ back? \_\_\_\_  
When and where was your last "ELVIS" sighting? \_\_\_\_\_  
Do you own any shoes (not boots)? YES \_\_\_\_ NO \_\_\_\_  
Can you sign your own name & always spell it right? Yes \_\_\_\_ No \_\_\_\_  
Have you EVER had more than one bath in a week? YES \_\_\_\_ NO \_\_\_\_

MARRIAGE: Are you married in any of the following (circle all that apply): ( ) Sister ( ) Cousin  
( ) Aunt ( ) Other, explain \_\_\_\_\_  
Does your wife weigh more than your pickup ( ) Yes ( ) No

MEDICAL INFORMATION  
Do you have at least two (2) of the following:  
( ) B.O. ( ) Crabs ( ) Lice ( ) Bad breath ( ) Scabies  
( ) Fleas/Tailions ( ) Crooked eyes ( ) Runny nose ( ) Brown Teeth ( ) Yellow Teeth  
( ) Any teeth ( ) No of teeth missing \_\_\_\_

GENERAL INFORMATION:  
Favorite weapon: ( ) The handle ( ) Pick handle ( ) Log Chain ( ) Shotgun  
Favorite pastime: ( ) Drinkin' ( ) Goin' huntin' ( ) Fishin' ( ) Other \_\_\_\_\_  
Truck equipped with: ( ) Gas tank ( ) Flasher ( ) S-Track  
( ) Rebel flag ( ) C.B. radio ( ) Bore case  
Favorite vocalist: ( ) Willie Nelson ( ) Johnny Cash ( ) Conway Twitty ( ) Loretta Lynn  
( ) Jim Nabors (see careful here)

Cap emblem: ( ) John Deere ( ) CAT ( ) SKOAL (Bridewester)  
( ) Back Ozarks ( ) Rebel Flag ( ) Wal-Mart

Memberships: ( ) NRA ( ) VFW ( ) KKK ( ) 700 Club ( ) B.P.O.E.

Your signature (use X with dot): \_\_\_\_\_ Date: \_\_\_\_\_



# EXPLOSIVES AND BOMB DISPOSAL GUIDE

By

ROBERT R. LENZ

*Explosive Ordnance Consultant*

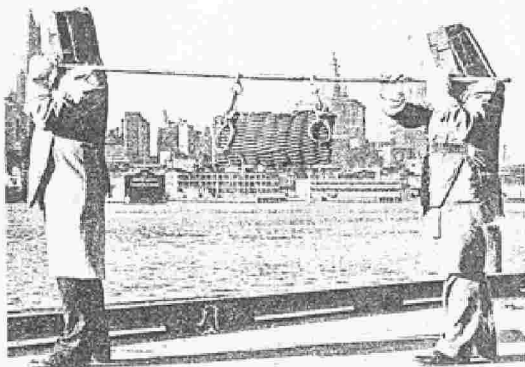

© 1964, by CHARLES G. THOMAS • PUBLISHER  
Library of Congress Catalog Card Number: 62-29051



*Published and Distributed Throughout the World by*

CHARLES G. THOMAS • PUBLISHER

BANNERSTONE HOUSE

301-225 East Lawrence Avenue, Springfield, Illinois, U.S.A.

NATCHEZ PLANTATION HOUSE

797 South Atlantic Boulevard, Fort Lauderdale, Florida, U.S.A.

## DEDICATION

*This book is dedicated to my family,  
to the New York City Bomb Squad,  
and to all Peace Officers who may  
contact explosive devices in the course  
of duty.*

## PREFACE

ON November 21, 1917, a bomb in a suspected package was carried into the Central Police Station in Milwaukee, Wisconsin. The bomb exploded violently as the officers were about to examine it, killing nine policemen and two civilian onlookers.

In February, 1933, a large heavy pipe device was turned over to the Army 61st Explosive Ordnance Disposal Team at Fort Sill, Oklahoma. Examination of the pipe disclosed thirty-two pounds of explosive phosphash powder and two electric igniters capable of detonating the pipe with a damage radius of one-fourth of a mile.

In May, 1963, a Canadian military bomb disposal expert reached into a mailbox to examine a suspected package and was met with a searing blast which completely severed his left arm and immediately terminated his career in Bomb Disposal.

The Canadian incident was not in vain, however, because it served the purpose of reminding all peace officers that the only effective way to combat explosive devices is through knowledge and research, and this book was then conceived for that purpose.

Three wars, compounded, have trained thousands of men in the use of demolitions and mine warfare, and have subsequently released these thousands back to civilian life.

Aggressor nations are training saboteurs and terrorists by the hundreds in the use of clandestine devices and improvised explosives, and they are being sown daily throughout the world.

Many psychotics roam the streets and, to gain attention, have turned to explosives, for there is no better weapon to strike fear and create panic than a carefully placed explosive device.

Saboteurs use explosives and incendiaries as a primary weapon because of their ability to disable or completely destroy the target.

Military, commercial, and "home made" or improvised devices are encountered daily by peace officers the world over. Newspapers headline the terrorists: unions, psychotics, and even teenagers who have utilized explosives as an effective weapon against society.

The author, through years of field experience, research, and teaching background, has attempted to consolidate the essentials needed to combat the ever-present threat of an explosive device or infernal machine. This large exchange and dissemination to the majority of interested parties can only be accomplished through the media of a well-organized publication.

Explosives are an unstable substance which, when subjected to the proper initiation, become stable, by unleashing tremendous power, accompanied by heat, blast, and terror. The damage and psychological effect are tremendous because such a weapon is not selective in its target. Any innocent person within its

lethal range becomes a potential victim.

There is no positive or fool-proof way to render safe any and all explosive devices, but this book will certainly afford a positive means of approach towards these deadly devices.

The means of initiating explosives and chemicals are countless in number and each device is limited only by the imagination of the perpetrator.

The subject material presented herein has been carefully planned to indoctrinate and orient all peace officers who may encounter explosive devices now or in the future.

Initially, it was the opinion of many that this book would be dangerous to publish, as it could accidentally fall into the hands of certain undesirable people. Perhaps this is true to some degree, but so is a gun in the hands of one who desires to use it against society.

The peace officer today can effectively combat a gun because he knows its capabilities and limitations through study, but the majority of peace officers have a very limited background in explosive devices because so few people, to date, have studied this subject.

The consolidated data and techniques within this volume should be disseminated to the proper agencies and it is the intent of the author that the book be solely for those agencies who have a "need to know." The agencies who would normally need to know this information would be Peace Officers, Fire Departments, Public Safety Units, Military EOD Units, Civil Defense Groups and certain educational institutions.

This manual combines material which has never before been assembled into one volume. It serves to supply a background of knowledge for any peace officer who does not have the many references, or qualified teachers, for bomb disposal training.

The peace officer with a good background in explosives can at least approach each situation with confidence, and perhaps succeed in his mission of rendering safe a device where previously a mistake through lack of confidence and knowledge could have been fatal to himself and innocent bystanders.

A favorite expression among bomb disposal technicians reads: "There are only two degrees of effectiveness in bomb disposal, initial success or complete failure!!"

R. R. L.  
P. O. Box 142  
Indian Head, Maryland

## ACKNOWLEDGMENTS

The New York City Police Department,  
B. Bowers, C. Newbouser, C. Jackson,  
Elizabeth Anne Luster, L. G. Sacy, W.  
E. Roberts, R. E. Smith, F. Philcox,  
R. E. Wallick,

R. R. L.

## CONTENTS

<i>Chapter</i>	<i>Page</i>
I. THE HISTORY OF EXPLOSIVES AND EXPLOSIVE	
ORDNANCE DISPOSAL	3
Background	3
Military and Explosives	3
Metropolitan, Civil Units and the New York City	
Bomb Squad	11

<i>Chapter</i>	<i>Page</i>
II. EXPLOSIVES AND EXPLOSIONS	14
Types of Explosions	14
Types of Explosives	15
Initiation of Explosives and Explosions	17
High Order and Low Order Detonations	18
Explosive Firing Trains	20
Sensitivity of Explosives	20
Methods of Loading or Packing Explosives	21
III. BLASTING SUPPLIES	23
Blasting Caps, Commercial Detonators, Igniters	
and Initiating Devices	21
Miscellaneous Tools and Blasting Equipment	30
Improvised Igniters, Detonators, and Assorted	
Burning Fuzes	33
Primers	34
IV. COMMERCIAL EXPLOSIVES	35
Dynamite	38
Ammonium Nitrate	42
Nitroglycerin and Disposal of Nitroglycerin	45
Military and Foreign Explosives	49
Primary High Explosives	51
Main Charge High Explosives	53
Sheet Explosives (EL-506 Du Pont)	59
Liquid Explosives	60
Home Made and Improvised Explosives	60
Miscellaneous Improvised Explosive Devices	63
Disposal of Explosives	63
Improvised Explosives Disposal	65
Explosive Solvents	67
V. EXPLOSIVE EFFECTS	68
Special Explosive Effects	68
Fragmentation Effect	69
Cavity and Shape Charges (Munroe-Effect)	70
Early Cavity Charge Experiments	71
Linear Cutting Charges	75
Misnay-Schardin Effect (Plate Effect)	74
Concentrated Blast Effect	75
Fougasse Effect (Improvised Shotgun)	77
Scabbing Effect	78
Sub-missile Effect	79
Striped Effect	79
Whistle or Startling Effects	81
Blast Effects on Automobiles	81
VI. INCENDIARIES (FIRE DEVICES)	84
Manufactured and Military Incendiaries	85
Improvised Incendiaries	86
Actual Incendiary Mixtures	87
Molotov Cocktails (Fire Bombs)	88
Pyrotechnics	90
Lacrymators (Tear Gas)	90
Sink Bombs	92
Hoax Bombs	93



Chapter	Page	Chapter	Page
VII. APPLIED PHYSICAL PRINCIPLES	96	Requirements for a Bomb Disposal Area	251
Power Sources	100	Vehicles and Special Equipment	258
Switches	103	Other Special Equipment	262
VIII. TRIGGERING METHODS, FUZING SYSTEMS, AND FIRING DEVICES	112	<i>Appendix</i>	
Military Fuzes, Firing Devices, and Systems	121	A. GLOSSARY	272
Miscellaneous Explosive and Incendiary Devices Illustrated	131	B. TECHNICAL REFERENCES, CONSULTANTS, BOOKS, GOVERNMENT MANUALS, AND EQUIPMENT MANUFACTURERS	282
IX. MILITARY MUNITIONS	168	C. DEMOLITION AND DISPOSAL "DO'S AND DON'TS"	285
Background	168	D. EXTRANEOUS ELECTRICITY	295
Classification	169	<i>Index</i>	298
Military Munitions	170	3	
Chemical Munitions, Mixtures, and Agents	177	<i>Chapter 1</i>	
Hypergolic Mixtures	182	THE HISTORY OF EXPLOSIVES AND EXPLOSIVE ORDNANCE DISPOSAL BACKGROUND	
Stink Bombs	182	<p>"THE unholly desire throughout the centuries for man to implement his belligerent impulses with superior devices for conflict, has provided the science upon which he has patiently constructed the most lethal scourge of the universe today, the high explosive bomb." (G. M. CHINN)</p>	
Contrived Explosive Devices	182	MILITARY AND EXPLOSIVES	
Simulators	183	<p>A good bomb disposal story could never be told without a brief history of the origin of early crude weapons progressing to modern day explosive ordnance. Starting during the days of the most primitive caveman, we find that the wooden club or "shül-lelagh" was universally employed for obtaining food, collecting wives, and clobbering his fellow man. Even today, as a reminder of its once devastating force, it is carried by certain high ranking military leaders and is called a "Swagger Stick," a symbol of the past and "A tribute to the man who wields the best club."</p>	
Protection Against Chemical Agents	185	<p>However, man in his increasing desire to conquer, progressed from the wooden club to better methods when he discovered that his neighbor retaliated with more effective means by throwing rocks and rolling huge boulders from a remote position in an effort to decimate his enemy remotely. Progress in weapons then began its normal course.</p>	
Nuclear (Atomic Bombs)	185	<p>What followed in the early years was inevitable. The stone axes, pikes, metal axes, swords, maces, projectile and fire catapults, cross bows, king bows, and even crude version of germ warfare made their appearance.</p>	
United States Department of Justice Federal Bureau of Investigation Letter	186	<p>About the time of Moses, history shows that the Chinese wrote in their code of laws a passage for thought which read, "The Magistrate will not make war with any deceitful machine, or poisonous weapons, or with cannons, guns, or any kind of firearms."</p>	
Information for Release to Representatives of Duty Constituted Law Enforcement Agencies	187	<p>Early in the year 1252, Roger Bacon described the use of black powder for military use by stating that it could "blow the enemy up or put him to flight by the terror of an explosion." Little did Roger Bacon realize at the time of these writings that the world would progress to the present day "nuclear methods" capable of destroying entire cities.</p>	
Civil War Ordnance	189		
Transportation and Disposal of Civil War Munitions	201		
X. EMPLOYMENT, MATERIALS, AND SUPPLY OF CLANDESTINE AND SABOTAGE DEVICES	202		
Personnel and Agencies Who May Employ Clandestine Devices, Improvised Explosives, or Sabotage Devices	202		
Containers and Materials Used in the Manufacture of Devices	203		
Employment (Prime Targets)	201		
Sources of Supply	205		
Analyzing and Evaluating a Bombing or Incendiary Problem	206		
Incident Report Forms and Bomb Files	207		
XI. APPROACHES TO RENDERING SAFE AND NEUTRALIZATION PROCEDURES	211		
Explosive Incident Categories (Priority of Attack) Categories	213		
Approach and Rendering Safe Phases	214		
Common and Special Tools	234		
XII. SAFETY DISTANCES AND EVACUATION PROCEDURES	238		
Evacuation	239		
Safety Distances and Formulae	210		
Detailed Search Procedure and Protective Works	243		
XIII. ORGANIZATION OF THE BOMB SQUAD	246		
Organization and Standard Operating Procedures	247		
Training	248		
Public Information and Press Releases	248		
Evidence and Preservation of Evidence	248		

Records indicate that gunpowder mortars, multiple-barreled guns, and cannons were in use as far back as the year 1300. History seems a little shady concerning weapons during this period, but we feel the shot used was of the solid type fired from smooth bore guns.

The first use of an explosive missile delivered by air, and not fired by a propellant, was recorded in 1849 when the Austrians used small charges of gunpowder attached to floating balloons against Venice.

The Civil War era, 1861-65, brought to the United States artillery shells, grenades, and crude mines capable of bursting internally in the air or on impact, and throwing fragments with a devastating effect. It is interesting to note that bomb disposal personnel are still recovering Civil War Ordnance, with black powder bursting charges just as effective as the day they were manufactured.

The year of 1866 ushered in a new era for explosives when Nobel mixed nitroglycerin with an absorbent material (blender) making it safer to handle. This new explosive was then classified as the "high explosive family." Further developments on nitration of materials in later years proved that this new type explosive has a more devastating effect when used as a main filler in various munitions, replacing explosive black powder.

5

The arrival of the aeroplane in 1903 added greatly to the wholesale fast delivery of explosive bombs, as demonstrated by the Italians in 1911, who dropped large containers of raw nitroglycerin on ground forces in Tripoli. (Incidentally, duals were at a minimum and pilots were known to grumble and complain considerably during these rather risky type of missions.)

In 1911, the Germans opened a new epoch in warfare by dropping high explosive bombs on Paris killing nearly one thousand people. Here was destruction indeed!

At this point however, Explosive Ordnance had not created a demand for trained disposal personnel inasmuch as early Civil War and World War I Ordnance were fitted with crude mechanical impact fuzes or powder-train time fuzes which presented no great problems for disposal. The dud ratio on this type of ordnance was relatively high because of the crude fuzeing systems used.

Records indicate that regular ordnance personnel of the British Royal Army Ordnance Corps undertook the job of disposing of the unexploded World War I bombs, dropped by Zeppelins from Germany, without much incident.

The year 1901 marked a definite turning point in the evolution of bombs and fuzes, because the German "Reinische Metallwaren und Maschinenfabrik" applied for patents throughout the world on a range of devices called "electric time and impact fuzes for projectiles and the like."

The Spanish Civil War (1936) presented the German Luftwaffe with the opportunity to estimate the performance capabilities of their new family of explosive bombs on live targets in a tactical situation. Needless to say, the results were successful. This should have been the signal for all countries to train bomb disposal personnel with up-to-date techniques. However, it was only briefly discussed and largely overlooked at this stage.

In February of 1940, the War Office of Great Britain decided to assign responsibility for bomb disposal after a few light bombings by German scout planes. The decision was too late, however. Late in 1940, the Germans cut loose on Great Britain with

6

everything but the "kitchen sink," including ordnance not previ-

ously studied by Ordnance Corps experts.

When the Germans captured the airfields in France and the lowland countries, they immediately started an intensive bombing of England. By dropping bombs fuzed with delays that functioned one and a half to eighty hours after impact, they achieved the effect of continuous bombing twenty-four hours a day. Long after the German bombers had returned to their homeland, the bombs continued to explode. The damage to property and to the war effort was heightened by the devastating effect on the morale of the people. Long-delay fuzed bombs, plus those that failed to go off because of a malfunction in the fuzeing, constituted ten percent of all the bombs dropped on England during the war.

All bombs that did not explode had to be considered time bombs until they were uncovered and proved otherwise. As a consequence, at the height of the blitz, more than 2,200 areas within the limits of metropolitan London were evacuated because of the presence of UXB's (unexploded bombs).

Factories and utilities were shut down, civilian morale was at a very low point and the war effort was virtually at a standstill. Through the joint efforts of the Royal Engineers, Navy, Air Force, and some of Britain's foremost scientists, an elaborate system was evolved for locating, rendering safe, and disposing of unexploded bombs. In England, science soon replaced luck and daring and the unexploded bomb ceased to be a nightmare.

The original British Bomb and Mine Disposal Squads are to be highly commended for their job, as theirs was extremely dangerous work and the records indicate that of the original forty-six volunteer personnel, only eight or nine remained alive by January of 1942. There is an old Explosive Ordnance Disposal expression which goes, "Those who remained alive were experts."

As a result of the British experience in mine and bomb disposal—the lessons they learned the hard way—the first U. S. Naval Mine Disposal School was established at the U. S. Naval Gun Factory, Washington, D. C. in December of 1941. Lieutenant D. L. Kauffman, USNR, became the first officer in charge of

7

the new school, which was established as a result of the directive issued by the Chief of Naval Operations as follows:

The U. S. Naval Bomb Disposal School

"The Chief of Naval Operations desires to proceed at once with the establishment and development of a bomb disposal unit."

So read the directive dated 9 December 1941. These units were to be organized in order to:

1. Safely dispose of bombs dropped on ships or naval establishments.

2. Recover bombs for study, when this is practicable.

This then, was the official beginning of the first bomb disposal organization ever to be incorporated into any American service. The first directive continues: Recommendations for the establishment of a bomb disposal school are as follows:

1. That the name of the school be the Bomb Disposal School and presently be located at the Navy Yard, Washington, D. C.

2. That the number of students for the first class be approximately fifteen officers and five enlisted men. As facilities become available, this number should be increased as necessary to meet requirements.

3. That the length of the course for the first class be approximately eight weeks. The length of the course for future classes should be determined by circumstances then existing.

The directive also specified, "assignment to bomb disposal duties will be on a voluntary basis only."

Thus, authority was granted to form the nucleus of what was to become an organization far greater in scope than was envisioned by its builders. It was not merely a school; it would more accurately have been called the Explosive Ordnance Center. It was here that over two thousand officers and enlisted men received training in bomb disposal and related work; that mobile training units were organized, outfitted, and supplied with intelligence; and that development of disposal methods and equipment was carried on.

The bomb disposal school, of necessity, was moved from the Gun Factory, in the fall of 1943, to a five acre plot in the campus

8

of the American University. The accomplishments of the personnel trained in these schools during World War II are a matter of history.

The "mission" of early bomb disposal units, as extracted from a Bomb Disposal Manual dated 1 Aug. 44, read: "The mission of the U. S. Navy Bomb Disposal is to minimize the damage done by unexploded bombs to ships of the Navy and Merchant Marine, and to shore areas and establishments important to these services; and to civilian shipyards and factories turning out material vital to the Navy or Merchant Marine. Further, it is the mission of Navy Bomb Disposal to provide the U. S. Navy with officers trained in U. S. Aviation Ordnance, booby traps and demolitions, and sufficiently versed in general ordnance to be of service to all commands in the solution of ordnance problems."

Shortly after the U. S. Navy established its school, the U. S. Army, in the Spring of 1942, established a Bomb Disposal School at Aberdeen, Maryland. The Officer-in-charge was Colonel Kane, USA. This school was much like the British Bomb Disposal School in England inasmuch as the Army had already sent students to the British School for training. Shortly thereafter Army Bomb Disposal personnel were to receive the mission of bomb disposal on all U. S. land masses. The Army still maintains an ordnance school where the original Bomb Disposal School stood in Aberdeen Proving Grounds, Maryland.

After the start of the U. S. Navy Bomb Disposal School, the failure percentage crept up and, as a result, considerable pruning was essential in order to maintain the necessary standards. In one enlisted class, there were only two graduates.

The school became the home base for almost every officer and enlisted man who satisfactorily completed the course. A rotation policy was set up, similar to the present system, so that after eighteen months the men were returned to the school for a refresher course. This had two most important advantages; the esprit de corps within the organization was kept at a high level, and the staff could be continuously supplemented with experienced personnel. The failure percentage of officers and enlisted men averaged around thirty-three percent. This included

9

those who were reassigned to specialized work and those who left early in the course that they had made a serious error in volunteering for this type of work.

In civilian education circles, such a failure percentage would be subjected to careful scrutiny, but not so for the Bomb Disposal School. Those who participated in this work obviously could not afford to make mistakes and it was, therefore, imperative that the standards be maintained at a high level. Instructors were selected from a graduating class and carried on the instruction program until experienced men returned from the field. The policy was to use experienced personnel in this department almost entirely.

Practical work, which represented about 25 per cent of the

instructional hours and counted very heavily in grades, was carried out in a two acre plot of ground near the classrooms and the Ordnance Investigation Lag at Stumpneck, Maryland. Digging, timbering, knot tying and use of equipment were taught there. Demolition and fuse stripping of live fuzes were also carried out. A small hut was constructed for use of classes acquiring a familiarity with booby traps. The same procedure is followed in the present bomb disposal school. The museum at the school was probably the best of its kind in the world and contained excellent displays of every warring country's ordnance.

By the summer of 1943, there were so many new developments in explosive ordnance that field personnel were unable to keep up-to-date in a satisfactory manner. To combat the problem, the school organized the mobile unit training program. There were two types of units—truckborn and airborne. Each unit had at least one officer and one enlisted man and expanded in some cases to two officers and four enlisted men. The truck units operated within the United States. Each unit was responsible for training the aviation ordnance personnel at the various bases within a specified area.

The trucks were fully equipped for giving a course of instruction that varied from one to forty hours. Seventeen of these units were in full swing when the war ended.

The airborne units were designed to give the same instruction

10

overseas. Five of these units operated throughout the Pacific, the Caribbean, and the Aleutians and completed their work early in 1945 to the full satisfaction of the many commands visited.

Another training activity which originated through the efforts of bomb disposal personnel was the Unexploded Ordnance School. Bomb disposal officers and enlisted men in the field encountered numerous instances of serious accidents and fatalities occurring when personnel picked up unexploded ordnance, both foreign and allied, either to dispose of it themselves or to make souvenirs from the recovered object. The dangers of such practices had been given only limited circulation. With these facts in mind, the first Unexploded Ordnance School in this country was opened at Fort Huachuca, California, Overseas, this had been done on a smaller scale at Bizerte. Both of these schools were immediately successful. The instruction program, as started at Fort Huachuca and subsequently developed at most of the other ten schools and units, was divided into two parts: a two day course for everyone and a two week course for a specially selected group who were to be bomb disposal assistants. The objective was to teach every man who went overseas how to recognize, avoid and report properly to bomb disposal personnel any item of ordnance that was found. By the summer of 1945, several thousand officers and enlisted men had received this training.

It is interesting to note that a number of women were also trained in the art of bomb disposal between the period of 1941 and 1945 to relieve male Marines in the states for overseas duty.

In November of 1945, shortly after World War II hostilities ended, the Naval Mine Disposal and Bomb Disposal Schools were combined and established as the Explosive Ordnance Disposal School at the U. S. Naval Receiving Station in Washington, D. C.

In August of 1946, the now combined school moved to the U. S. Naval Powder Factory on Jackson Road, Indian Head, Maryland.

In 1947, the Bureau of Naval Weapons foresaw the need for a separate unit to conduct Explosive Ordnance Disposal research and development and thereby designated the first Explosive Ord-

11

name Disposal Unit for research, development tests, and evaluation at the U. S. Naval Powder Factory as an integral part of the school. This unit was later designated as the Explosive Ordnance Disposal Technical Center and at present is entitled Explosive Ordnance Disposal Facility, and located at Stump Neck Annex, Maryland. The facility is now separated from the Explosive Ordnance Disposal School and has its own Commanding Officer.

The Explosive Ordnance School, which was located on Jackson Road, Indian Head, Maryland; began about 1948 teaching classes to all members of the armed services and again was forced to move into new and larger quarters, in 1958, on Strauss Avenue where it presently stands.

The mission of the Explosive Ordnance Disposal School has changed considerably since its beginning in the old U. S. Naval Bomb Disposal School and now reads:

"Mission of the U. S. Naval Explosive Ordnance Disposal School"

*Under the direction of the Chief of Naval Personnel to train selected officers and enlisted personnel of the Navy, Army, Air Force, and Marine Corps, including the Naval and Marine Reserve, in the best methods and procedures for recovery, evaluation, and disposal of the surface and underwater explosive ordnance employed by the United States and by other nations.*

#### METROPOLITAN, CIVIL UNITS AND THE NEW YORK CITY BOMB SQUAD

It is difficult to state when or where the first metropolitan bomb squad was organized for the purpose of combating the threat of civil bombs, psychotic bombers, or terrorists. The rival gang wars and bombings during the "Roaring Twenties" certainly indicated the need for such training, as bombings were almost a daily incident in major east coast cities.

Most larger metropolitan cities today have organized and trained bomb disposal personnel based, to some degree, on the number of incidents handled. The largest and perhaps most

12

highly trained of these units is the New York City Bomb Squad which maintains an efficient unit, described herein.

#### New York City Bomb Squad

The New York City Police Department Bomb Squad was founded in April 1903, at a time when bombs were common instruments of extortion among foreign born residents of New York City. Among its first members and early commanders was the famous Lieutenant Joseph Petrosino who was to be killed in the performance of duty some six years later and three thousand miles away in an investigation that began on the streets of New York City.

After Petrosino's death and the break-up of the secret societies and organizations that had precipitated it, the bomb squad turned its attention to the anarchists who had adopted the bomb as a weapon of terror in the days that preceded World War I.

Upon this country's entrance into that war, members of the bomb squad were attached to Intelligence Departments of the Army and Navy and had as their chief mission the prevention and detection of sabotage.

A period of social unrest following the war culminated in the infamous Wall Street explosion of September 16, 1920, in which thirty-nine persons were killed and hundreds injured, and which launched one of the most extensive investigations ever conducted

by this squad.

In the 1920's and 1930's, bombs were often employed by racketeers and it was against such activities that the resources of the bomb squad were chiefly directed.

On July 4, 1940, just prior to the outbreak of the Second World War, detectives Joseph Lynch and Ferdinand Socha of the bomb squad were killed by the explosion of a bomb they had just removed from the crowded British Pavilion of the New York World's Fair.

From 1911 to 1957, some thirty-three bombs were set in various places of public assembly throughout the city by a "mad bomber." The arrest of George Metesky climaxed seventeen years of intensive police investigation.

13

In the last three months of 1960, a series of Sunday bombings culminated in the death of a fifteen-year-old girl aboard a subway train. The case is still active.

Thus, through the sixty years of its existence, the bomb squad has successively combatted the secret societies, the anarchists, the saboteurs, and the demented—all of whom used the same common denominator—the bomb. In recent years, a new group has been added—the racial terrorists. A nationwide increase in this type of bombing has made many law enforcement agencies acutely aware of their limitations in this area. The bomb squad provided training for many members of these agencies and made available information based on the experience of the oldest and most active organization of its type in American police history.

Each year the bomb squad investigates and handles over one thousand incidents involving bombs and explosives in New York City. These range from the unfounded telephone threat to the live bomb.

The New York City Police Department has a bomb squad composed of members of the Detective Division, operating on a twenty-four hour basis. This squad is assigned to the handling, dismantling, and disposal of bombs, explosives, and suspicious packages; and to the investigation of explosions.

Applicants for this type of duty are initially selected from those members of the department who have had prior civilian or military experience in demolition, explosives, and ordnance. After a three month training and trial period in the bomb squad; encompassing the use and operation of technical equipment, and the handling and dismantling of infernal machines, suspicious packages, and military ordnance; those trainees displaying special aptitude and ability are then permanently assigned to the bomb squad.

14

#### Chapter II

### EXPLOSIVES AND EXPLOSIONS

EXPLOSIVES today present a great challenge to society because of the fantastic power released in micro seconds.

This power cannot be underestimated and I have seen explosives through the years perform unpredictable and unbelievable feats.

During World Wars I and II, and up to the Korean war, the effects gained by explosives were primarily of the blast nature but three wars and stepped-up research have ushered in newer effects of explosives; such as deep penetration of steel and concrete, directional effects in the form of ultra high speed fragments and shrapnel and white hot jets.

In one instance, forty pounds of explosive drove an eight ton

block of steel approximately twenty feet into the air and set it down some sixty-five feet from its original resting place. This power measured in foot pounds is almost unbelievable.

In other cases as little as one pound of explosive can drive a hole instantly through almost two feet of reinforced concrete.

We can readily see, by the above statements, the need for being familiarized with explosives and the newer effects of explosives.

#### TYPES OF EXPLOSIONS

An explosion may be defined as a bursting or violent expansion as a result of a sudden production or release of pressure. It is always accompanied by a loud noise, high temperature, and usually by a large volume of gas.

We normally classify explosions as three types, these being:

15

1. **Mechanical**—Steam building up in a boiler with a defective safety device will cause a sudden rupture of the case and a mechanical explosion will occur.
2. **Chemical**—Results from an extremely rapid conversion of a solid or liquid explosive compound into gases. An instantaneous change normally called a detonation or delagration. Most military munitions will utilize explosive compounds which will undergo the chemical type of explosion. Chemical explosions are normally accompanied by extreme heat, loud noise and, in some cases, violent shock.
3. **Nuclear (atomic explosion)**—This type of explosion is accomplished when the nucleus of an atom is split releasing tremendous energy. This type of explosion is also accompanied by extreme heat, loud noise, violent shock, and radiation or radioactive effects. A further breakdown of atomic bombs and explosions is given in Chapter 9.

#### TYPES OF EXPLOSIVES

Explosives are unstable chemical compounds found in a solid, liquid, or gaseous form. They are substances that, when heated, struck, or shocked by another explosive, are capable of producing an explosion by liberation of great quantities of heated gas.

Being an unstable substance, they are always attempting to become stable. Therefore, when subjected to the proper initiation, they will become stable either by rapid burning or by detonation (instant combustion) depending, of course, on the type of explosive.

The speed with which an explosive compound decomposes or explodes will normally determine its type.

We normally classify explosives as being of three types:

1. **Low explosives**—These are often referred to as the burning explosives such as black powder, rifle powder, etc. They are not normally designed to explode violently as they are usually used to propel bullets from gun tubes and to project rockets into the air. They will, however, detonate or explode violently under certain conditions if confined properly and are often used by psychotics and saboteurs because

16

of their availability. Initiation of low explosives is relatively simple to achieve (spark or flame in most cases) making them even more desirable to bombers.

2. **Primary high explosives**—These explosives are extremely sensitive to heat, shock, or friction and, under normal conditions, will detonate violently instead of burning. They have the strength needed in small quantities to initiate or detonate secondary high explosives and are usually used for that purpose. They are often referred to as primers or deto-

natons and in most blasting caps provide the main ingredients used. Because of their violent and sensitive nature, primary high explosives are naturally treated with care and require controlled conditions in the manufacturing phases. Because of the sensitive nature of this group, they are normally quite well controlled by the supply houses and are almost impossible to improvise outside of laboratory conditions. Psychotics and saboteurs will normally resort to a more simple type of explosive to accomplish their mission. Most primary high explosives are usually procured by theft or other clandestine means by those who have an evil purpose in mind. Certain states, however, have relaxed laws regarding both primary and secondary high explosives.

3. **Secondary high explosives**—These include the vast number of high explosives which are relatively insensitive to heat, shock, or friction and will normally burn rather than detonate, if ignited in small quantities in the open air. For this reason, they are primarily used as booster charges and main bursting charges in most cases. Some examples of common secondary high explosives are: military TNT, ammonium nitrate, dynamite, etc. Secondary high explosives are also difficult to manufacture or improvise outside of controlled laboratory conditions, but there are known cases of certain undesirables who, with the proper background, have manufactured, illegally, nitroglycerin and added a desensitizer to make an effective explosive.

17

#### INITIATION OF EXPLOSIVES AND EXPLOSIONS

In all explosions, there must be an initiator or initiating action to induce or start the explosion or chain of events leading to the explosion. The usual methods of initiation are:

1. **Ignition**—The explosive is fired by an electrically heated wire, similar to a spark plug in an automobile engine, which explodes the gas vapors.
2. **Inflammation**—The explosive is fired by a flame produced from a fuse similar to a firecracker fuse.
3. **Percussion**—The striking of percussion caps and primers which in turn detonate or ignite the main charges. Example is a firing pin in a rifle striking the percussion cap and igniting the propellant.
4. **Friction**—Often referred to as a **friction primer** and acts much like striking a match on the abrasive coating of a match book.
5. **Detonation**—A strong shock wave set up by primary and secondary high explosives which will cause the explosive to explode or detonate at its maximum rate. A good example of a detonating initiation is a stick of dynamite primed with a blasting cap which, when fired, will cause an immediate explosion or detonation.
6. **Exploding wire detonation**—A rather complex method, which is achieved by building up extremely high voltages and releasing these high voltages suddenly into certain types of thin wires. This will cause the wires to explode and create enough shock to detonate high explosives. This method is often referred to as the "exploding bridge wire."

#### HIGH ORDER AND LOW ORDER DETONATIONS

Many bomb disposal technicians will use the terms "high order" and "low order" during disposal operations and these terms pertain to the manner in which the explosive that they are dealing with detonates. A technician with years of field experience can merely listen to a detonation and ascertain whether the entire block of explosive was consumed. The terms "high" and "low" mean:

18

1. **High order detonation**—This term indicates that the explosive completely detonated at its maximum velocity. During this type of detonation, the entire mass was consumed or exploded at the rate normally expected.
2. **Low order detonation**—This term indicates that the detonation was incomplete or detonated at a rate lower than its maximum expected rate. These factors can be caused by such conditions as:
  - a. Deteriorated (old explosive).
  - b. Improper initiator.
  - c. A poor marriage or lack of continuity, such as separation of the blasting cap and main charge.
  - d. Accomplished purposely by a trained technician who desires a low order detonations such as in bomb disposal.

In most cases a low order detonation will leave chunks or powdered explosive spread in a large area around the site of the detonation.

Many bomb disposal personnel uses classified techniques to attempt the low order detonation of larger bombs and various munitions. It is amazing that, in many cases, they can cause a bomb containing five hundred pounds of explosive to split and open and merely burn harmlessly. More amazing is the fact that they use explosives **against** explosives. In some instances, low order detonations will detonate half of the explosive in the bomb case at an ear-splitting rate and leave the other half lying around the area in huge chunks.

#### EXPLOSIVE FIRING TRAINS

Most explosives and explosions require what is termed as the firing trains to achieve initiation. These are a series of steps by which a small initial amount of energy is built up to the large amount required to insure the explosion or detonation. Explosive trains will vary in structure from very simple to complex, depending on the actions required (Figures 1 and 2).

19

The general firing trains listed in most manuals are:

1. Basic propellant train.
2. Basic high explosive train.
3. Time action high or low explosive train.
4. Superquick action high or low explosive train.
5. Powder train delay action train.

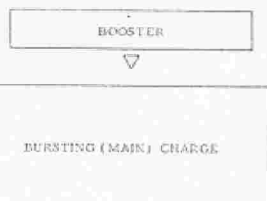
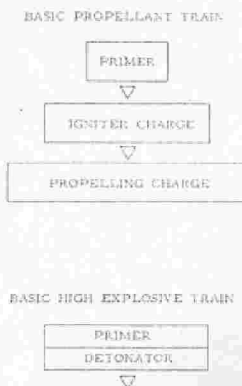

FIGURE 1. Propellant and high explosive train.

#### BASIC TIME DELAY ACTION TRAIN

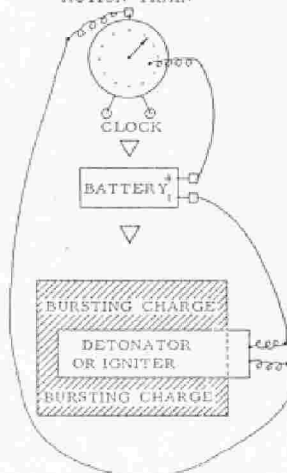

FIGURE 2. Time delay train.

#### SENSITIVITY OF EXPLOSIVES

The sensitivity of explosives are normally determined by the ease with which they can be initiated. Pure nitroglycerin, for example, can normally be initiated by merely dropping the container on a hard surface, whereas a desensitized explosive such as TNT would require normally a severe shock.

Most explosives are desensitized to some degree in the manufacturing process, but various conditions can cause a chemical change that can render an explosive compound so sensitive that the heat of the human body alone may cause it to detonate. An example of this is badly decomposed nitroglycerin in a metallic container.

21

Most explosive manufacturers laboratory test explosives under controlled conditions prior to shipping to insure the degree of sensitivity. The factors which will affect the sensitivity of an explosive are:

1. Crystal size.
2. Density.
3. Temperature.
4. Moisture.
5. Coating of the crystals (wax, etc.).
6. Distortion of the crystals.

Most military secondary high explosives are required by specifications to be rather insensitive to heat shock or friction but

certain commercial high explosives are quite sensitive because of cost of manufacture for public use.

We should never underestimate the sensitivity of the explosive regardless of specifications, as they are used only as a guide for users.

Some factors which may cause certain chemical changes to make an explosive dangerous for handling are:

1. **Reaction with certain metals** - Sensitive salts are formed.
2. **Temperature changes** - Extreme heat or cold.
3. **Powdered explosives** - Powdering of high explosives caused by rough handling of containers can be extremely dangerous.
4. **Chemical reactions** - Certain explosive compounds subjected to periods of prolonged unstable storage can form explosive gases and salts which will cause them to spontaneously ignite or detonate and be hypersensitive to handling because of their erratic nature.

**METHODS OF LOADING OR PACKING EXPLOSIVES**

Most explosives are loaded into ammunition or packed into certain containers as follows:

1. **Cast loaded** - Often referred to as melted, poured, and cooled. This method provides for a high density explosive and is found as a solid. Most U. S. military high explosives are cast loaded. Example, TNT in most munitions.
2. **Press loaded** - The explosive is powdered and pressed into the container with a ram. This process is time-consuming and not too desirable.
3. **Extrusion method** - The explosive is led into a hopper and extruded into the container by means of a worm gear screw.
4. **Pouring** - Powdered or flaked explosive is poured into the container. Many explosive hand grenades are loaded in this manner.
5. **Block fitted** - The explosive is pressed into blocks and merely inserted into the munition or container.
6. **Hand loading** - Certain plastic (pliable) explosives are loaded into containers in the field by merely shaping it like putty and packing the container by hand.

28

**Chapter III**

**BLASTING SUPPLIES**

**M**OST explosives and devices must be destroyed by the application of explosives against explosives. Therefore, the training of bomb disposal personnel in the use of explosives is of the utmost importance. The best way to train bomb disposal personnel is by actual field training in the handling and use of demolition materials. Confidence in demolition can only be gained by actual use. Books and manuals are important, but the fear of handling demolition materials can only be overcome by close contact and familiarization with the materials. It is recommended that any department organizing a bomb squad send the team members for a special course in the use of demolitions and blasting supplies. In many cases, this training can be accomplished by liaison with nearby large military installations or military explosive ordinance disposal units. The following sections will explain certain blasting supplies and their use, but actual field training is essential and the instructions should be given by a thoroughly trained technician fully aware to the hazards involved. Confidence in the use of explosives will come with

field training and the effects of explosions will be learned during this same course.

21

**BLASTING CAPS, COMMERCIAL DETONATORS, IGNITERS AND INITIATING DEVICES**

1. **Blasting caps** - These are grouped into two major categories, electric and non-electric, and are short capsules of copper

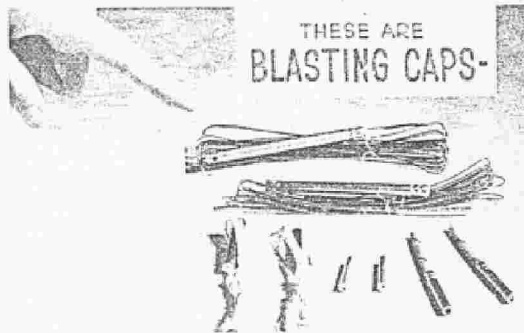

FIGURE 3. Blasting caps electric and non-electric. (Courtesy Institute of Makers of Explosives.)

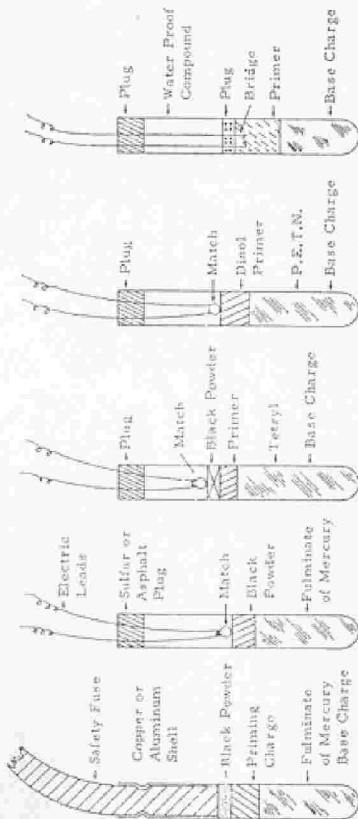

FIGURE 4. Assorted blasting caps, commercial. Army engineer, special electric and non-electric.



25

or aluminum closed at one end. They contain a small quantity of one or more of the more sensitive high explosives. Regardless of their size they are very powerful and are sensitive to heat, shock, or friction, and must be handled with care. They are used to propagate the detonating wave which will explode main charge high explosives. Blasting caps can be initiated by means of a burning time fuze or by electrical wires and battery power applied. Most blasting caps are about the diameter of a lead pencil ( $\frac{1}{4}$ " ) and will range in length from one inch to six inches.



FIGURE 5. Non-electric blasting caps, package of 100. (Courtesy E. I. Du Pont de Nemours & Co.)

2. **Detonating cord (primacord)**—Detonating cord is a detonating (exploding) fuze used for initiating commercial explosives by transmitting a detonating wave down the length of cord into a main charge explosive. It is a very strong, flexible cord about one-fourth inch in diameter with a core containing a powerful explosive. When the detonating cord or primacord is initiated with a blasting cap, the velocity of detonation reaches approximately 21,000 feet (four miles) per second.

26

Primacord, when detonated, has the initiating energy of a blasting cap at all points and will transmit the detonating wave from one end to the other when initiated. It can be assumed that if one end of a strip of detonating cord were inserted into a dynamite stick, reeled out four miles and initiated, the detonating wave would strike the dynamite in one second and explode or detonate the stick. Whereas blasting caps are extremely sensitive, detonating cord is considered quite insensitive to heat, shock, or friction.

A high degree of safety is therefore present in the use of detonating cord and it is used considerably by many military operations. Detonating cord is normally issued on spools for easy handling and ranges in color and appearance from a waxy external to a shiny plastic. The Ensign-Bickford Company of Simsbury, Connecticut produces a wide variety of detonating cords for many field applications and, used as a branch or trunk line, it will initiate many charges simultaneously without the necessity of using multiple blasting cap hook-ups. An additional safety feature in the use of detonating cord is that it is not susceptible to extraneous electricity (lightning, etc.) and affords maximum safety during blasting operations.

27



DETACORD®



PLAIN PRIMACORD®



REINFORCED PRIMACORD®



PLASTIC REINFORCED PRIMACORD®



PLASTIC WIRE COUNTERED PRIMACORD®

FIGURE 6. Primacord (detonating cord, assorted).

28

Safety is increased by use of detonating or primacord during blasting operations as a means of detonating a main charge.

3. **Igniters**—Igniters are used primarily to ignite rocket motors, simulators, noise makers or black powder devices. They are usually manufactured in a plastic or metallic container and will contain a black powder igniting charge when initiated. Some igniters, called "squibs", closely resemble blasting caps but are used for ignition rather than detonation. Most igniters are of the electrical variety but some commercial firms use time or slow burning fuze as a means to ignite certain devices.

4. **Safety fuze (time fuze)**—Safety fuze is a medium through which fire is conveyed at a continuous and uniform rate to the non-electric blasting cap or explosive charge. It consists of a train of special black powder fuze, supported and encased in various wrappings of textile and waterproofing materials.

Safety fuze is slightly smaller in diameter than a blasting cap and is usually issued or sold in 50-foot coiled lengths. The fuze has a waxy appearance and will come in colors: such as orange, black, and white wax. Burning time averages about 45 seconds per foot.

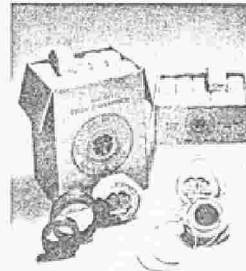

FIGURE 7. Safety fuze, 50-foot coiled lengths.



FIGURE 8. "Ignition spit" — a jet of flame which shoots out of the end of the safety fuse as the powder train is ignited. A jet of flame called the "end spit" shoots out of the other end of the fuse when the powder has burned through. (Courtesy of the Ensign-Bickford Company.)

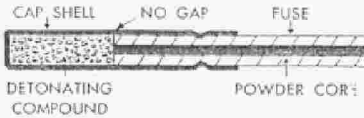

FIGURE 9. Safety fuse crimped properly into non-electric cap. (Courtesy of the Ensign-Bickford Company.)

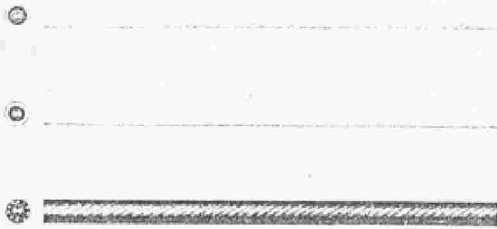

FIGURE 10. Assorted styles of safety fuse. (Courtesy of the Ensign-Bickford Company.)

MISCELLANEOUS TOOLS AND BLASTING EQUIPMENT

1. **Crimpers** — Cap crimpers are small tools resembling a pair of pliers, which are used to securely fasten a blasting cap to the safety fuse. They consist basically of crimper jaws, cutting jaws, a punch on one handle, and a screwdriver blade on the other. They are normally constructed of a non-sparking type of metal and are essential for safety and efficiency in non-electric blasting operations.

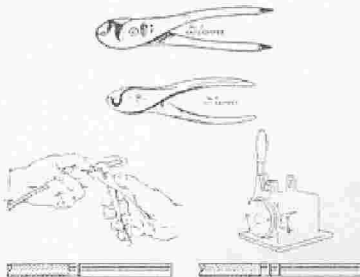

FIGURE 11. Cap crimpers. Upper set for hand crimping and lower set is the Du Pont Superior machine crimper.

2. **Blasting machines** — Blasting machines are used to generate current for firing electric blasting caps during field disposal operations. They are operated by a quick twist of a handle or, the larger machines, by a downward thrust of a plunger. Some machines are magnetos but the large majority are modified generators. They are normally rated by the number of copper wire

electric caps they can be depended upon to fire in a straight series circuit. They range in capacity from one cap to 100 caps.

It is interesting to note that many disposal personnel have appropriately nicknamed these machines as "hell boxes".

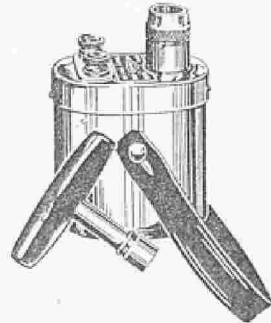

FIGURE 12. Du Pont pocket type ten cap blasting machine. (Courtesy E. I. Du Pont de Nemours Co.)

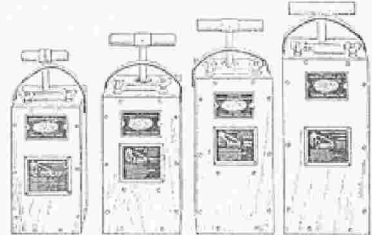

FIGURE 13. Blasting machines, large capacity plunger types. (Courtesy E. I. Du Pont de Nemours Co.)

3. **Fuze Lighters** — Fuze lighters are manufactured to provide a quick sure method of igniting safety fuze. The two most common types are the pull wire type and the automatic cocked pin type. They contain an internal ignition compound which readily ignites the fuze when initiated.



FIGURE 14. Pull wire fuze lighter.

4. **Circuit testers (galvanometer)** — This instrument is used by blasters to test the circuit prior to electrical initiation and to determine that the circuit is complete for firing. This machine will indicate the existence of leaks or short circuits and the approximate resistance of a circuit. A small current generated by a small silver chloride battery within the galvanometer is sent through the circuit and blasting caps and on its completion will

register on the machine's needle-like pointer. The machine, in addition, can be used in series on other circuits to check on breaks within the circuit.

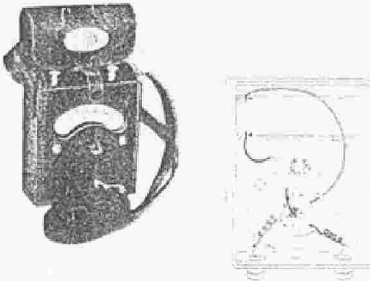

FIGURE 15. Du Pont electric tester (galvanometer) with carrying case (Courtesy: E. F. Du Pont de Nemours Co.)

33

### IMPROVISED IGNITERS, DETONATORS, AND ASSORTED BURNING FUZES

1. **Improvised igniters**—Consists of electrical or mechanical devices designed to initiate an incendiary or explosive by means of a brisk flame. Some of the more common types of improvised igniters are:

a. **Light bulbs:** Flash bulbs and light bulbs are often used by drilling or filing the ends of a bulb and filling the bulb with various flash mixtures such as black powder or photo-flash powder. The bulb is then fired by wires which are soldered to the base of the bulb and electrically initiated.

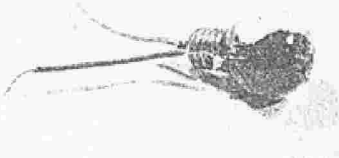

FIGURE 16. Improvised electrical light bulb igniter filled with black powder.

b. **Potassium chlorate and sugar igniters:** Used widely as an igniter mixture or sometimes as an explosive filler. These mixtures can be ignited easily by flame or sulphuric acid delay mechanism.

c. **Glo-plugs:** Model aircraft hobby shops utilize a small spark plug called a glo-plug. These are often used as a hot wire type of igniter. They are threaded into pipes or like devices to ignite black powder or smokeless powder by means of a time delay and electrical current.

d. **Rifle, shotgun and pistol cartridges:** Widely used as a percussion type of igniter. In assembling this type of igniter, the perpetrator merely removes the slug or projectile, closes the open end with wadding and constructs a firing pin of some type. This type of igniter is used considerably by professional terrorists and saboteurs to ignite black powder bombs and incendiary devices.

2. **Improvised time fuzes**—These are constructed by use of various burning powders and certain chemical mixtures. Some of

the more commonly improvised fuzes are:

- Cotton string impregnated with solutions of potassium chlorate and sugar.
- Assorted commercial fireworks fuzes.
- Cotton string saturated with wet black powder or smokeless powder and sun dried.
- Mixture of household glue and black powder used to impregnate cotton string.
- Mixture of potassium permanganate, flour, and sulphur inserted into common drinking straws.
- Model airplane timing fuze sold for a burning timer on model airplanes.

3. **Improvised Detonators**—These will rarely be encountered improvised, as it is extremely dangerous to attempt to construct a detonator (blasting cap) outside of laboratory conditions.

### PRIMERS

Primers are generally found as small devices containing a priming compound used to produce fire or small explosions to transmit flame or heat to ignite propelling charges, fire heat sensitive detonators, or start rocket igniter devices. Igniters are generally grouped into the percussion or friction types as to initiation. A good example of a primer device is the small round primer found in the center of the base of a standard shotgun shell. The blunt firing pin of the shotgun strikes the primer briskly, transmitting a spit of flame to the smokeless powder, driving the pellets from the barrel of the gun. Primers are often used by terrorists for ignition purposes and can be procured in most gun shops where re-loading supplies are sold.

55

### Chapter IV

## COMMERCIAL EXPLOSIVES

THE following list of commercial type explosives are perhaps the most general types encountered by peace officers today. Included in the forms are some key identification features and characteristics which may prove valuable should the explosive be encountered. A separate section has been devoted to nitroglycerin because of its sensitivity and the extreme hazards involved in dealing with this explosive. In addition, dynamite is included as a separate section because of the many types found and because of its wide use.

The explosive forms contain such information as: color, detonating temperature, sensitivity, initiation, and disposal methods.

Commercial explosives are normally encountered more by the peace officer than military explosives because of their availability to civilians. In many cases, psychotics and saboteurs will resort to theft of a civilian construction storage site as a means of obtaining bulk explosives (Figure 17). These storage sites in a majority of cases will house the blasting caps, time fuze, and bulk explosives all in one magazine or bunker. Breaking into this type of site provides the undesirable with all the essentials needed to trigger a bomb and prevents detection as would be the case if a purchase were made.

56

### COMMERCIAL EXPLOSIVES (Low)

NAME:	Black powder
COLOR:	Shiny black, or brown
TYPE:	Low explosive
DETONATING TEMPERATURE:	Ignition temperature 300°C
LOADING METHODS:	Pouring or press loaded
SENSITIVITY:	Extremely sensitive to heat, shock, or friction
USE:	Blasting agent, propellant, blasting charge, initiator, quickmatch, safety fuse.

and primers  
 INITIATION REQUIRED: Spark, flame, detonator, or a sharp blow.  
 REACTION WITH METALS: Unknown  
 DISPOSAL: By burning, or dumping into a fast moving stream of water

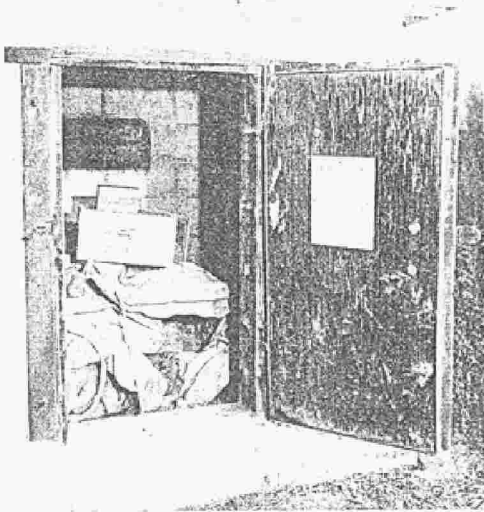

FIGURE 17. Construction site explosive storage locker broken and entered for explosives.

REMARKS: Black powder is considered to be the most dangerous explosive known because of its sensitivity. When disposing of black powder by burning a 25-foot ignition train should be used as it has a burning speed of 1 to 10 centimeters per second at pressures up to 30000 pounds per square inch. It is widely used by saboteurs and psychotics as a burning charge. It can be readily purchased in gun shops without signature as a re-loading agent for various cartridges and is, therefore, encountered by many peace officers; being used in assorted pipe bombs, etc.



FIGURE 18. Blasting powders showing exact sizes of various types and grades.

COMMERCIAL EXPLOSIVES

NAME: Smokeless powders (single base)  
 COLOR: Black, amber or brown  
 TYPE: Low explosive  
 DETONATING TEMPERATURE: Ignition temperature 315°C. may detonate if confined and ignited  
 LOADING METHODS:  
 SENSITIVITY: Ignition is difficult but care should be exercised  
 USE: Blasting agent or propellant powder  
 INITIATION REQUIRED: Primer, spark, detonator, or flame  
 REACTION WITH METALS: Unknown  
 DISPOSAL: By burning  
 REMARKS: Has a burning speed of 1 to 18 centimeters per second and is also widely used by psychotics and saboteurs as a main charge for bombs. If confined, it may detonate violently.



FIGURE 19. Smokeless powders sold in gun shops.

DYNAMITE

Dynamite is used rather extensively by psychotics, saboteurs, satecrackers, and other undesirables because of its availability and shocking power.

Dynamites are usually used commercially as a blasting agent and can be grouped into the basic types listed below:

1. Straight dynamite.
2. Blasting gelatin.
3. Gelatin dynamite.
4. Low freezing and nonfreezing.

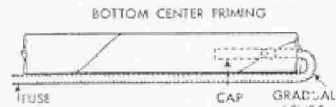

FIGURE 20. Dynamite cartridges: one primed, one unprimed. (Courtesy E. J. Du Pont de Nemours & Co.)

5. Military dynamite.
6. Permissible dynamite.
7. Ammonia dynamite.

All dynamites except military dynamite contain nitroglycerin plus variations of absorbent materials, oxidizers, etc. The strength of various dynamites is indicated on labels, such as 40 per cent indicating that the dynamite contains 40 per cent of nitroglycerin by weight.

Dynamites of various types range in detonating velocity from

4,000 feet to 23,000 feet per second.

Most dynamites have a lower detonating rate than military high explosives making them suitable for commercial mining because of the "heaving" or pushing effect.

Most dynamites are sensitive to heat, bullet impact (shock), and friction. They also will detonate if burned in large quantities. Dynamite requires a detonator as a means of initiation (electric or non-electric cap).

Straight dynamites, because of their nitroglycerin content, are considered to be very sensitive at a certain temperature in a frozen state.

Dynamite ranges in color, but most will be found as a reddish

40

yellow to brownish yellow and resemble a crumbly plastic mass. Gelatin dynamites, however, are more plastic than the straight dynamites and can be moulded better.

Many undesirables, such as salcrackers, extract the raw nitroglycerin in various forms from dynamite and use this as a blasting agent. The procedures used in this method of extraction are covered in the nitroglycerin section.

Dynamites are furnished in a wide variety of sizes. They are usually divided into two classes; small cartridges, being under four inches in diameter; and large cartridges, being over four inches in diameter.



FIGURE 21. Dynamite cartridge with marriage or joining tube. (Courtesy E. I. Du Pont de Nemours Co.)

The most popular diameters are  $1\frac{1}{8}$  and  $1\frac{1}{4}$  inches by eight inches in length. In large size diameters, four to six inches seem to be more in demand with lengths up to thirty inches. Most cases of dynamite are shipped fifty pounds to the case. The cases are constructed of wood or fiberboard.

The disposal of dynamite will be found in the disposal section of this book. Dynamite, however, can be burned in small quan-

41

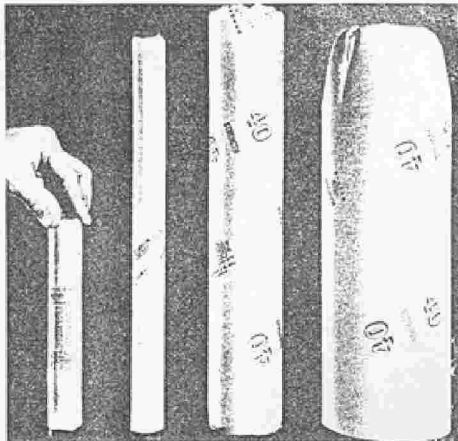

FIGURE 22. Assorted dynamite cartridges.

ties) or detonated. The recent trend in dynamites seems to be to use ammonium nitrate as a substitute for sensitive nitroglycerin.

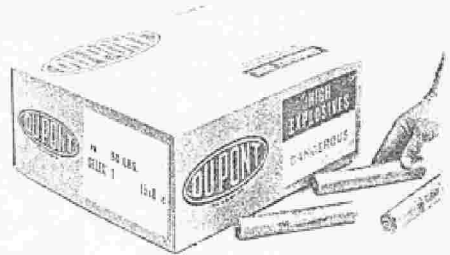

FIGURE 23. Dynamite case, 50 pounds. (Courtesy E. I. Du Pont de Nemours Co.)

42

### AMMONIUM NITRATE

The use of ammonium nitrate (fertilizer grade) as a high explosive is quite possible, but requires more than just walking into a hardware store, picking out a fertilizer, and priming it into a bomb. The fact that it can be used as a lethal high explosive is evidenced by several recorded cases. Perhaps the most prime example is the Texas City, Texas disaster of 1947 where a shipload of fertilizer grade ammonium nitrate exploded and almost destroyed the entire city, with a death toll of over 500 people.

Ammonium nitrate coupled with confinement, water, and excessive high temperatures will form dangerous ammonia fumes and gases which may detonate as evidenced by the above disaster.

Raw ammonium nitrate is an oxidizing agent that, mixed with



FIGURE 24. Ammonium nitrate pill. (Courtesy E. I. Du Pont de Nemours

a sensitizing agent (fuel oil) and properly primed with a blasting cap and booster, will detonate with violence. It requires confinement to propagate a good detonating wave but, once started, it will detonate at rates up to 14,000 feet per second. Ammonium nitrate explosives, if mixed properly, can be compared in strength to a good 60 per cent straight dynamite mixture. The mining industry and the military have been researching the use of ammonium nitrate as an explosive quite vigorously the past few years because of the low cost as compared to other explosives. The Du Pont Company produces ammonium nitrate "prills" ready for use in cratering and blasting operations (Figure 24). These prills, however, are quite highly refined compared to fertilizer grades and, in this higher grade, will require only a detonator and good booster for detonation.

Ammonium nitrates, because of their availability, should certainly be considered as a ready "do-it-yourself kit" for psychotics and saboteurs possessing an explosive training background.

-44



FIGURE 25. Ammonium nitrate primers. (Courtesy E. I. Du Pont de Nemours

Co.)  
45

FIGURE 26. Military ammonium nitrate cratering charge. Forty pounds of ammonium nitrate (nitramon).

#### NITROGLYCERIN AND DISPOSAL OF NITROGLYCERIN

Nitroglycerin (glyceryl trinitrate) was first prepared in 1816 or early 1847 by an Italian named Ascanio Sobrero. Sobrero kept his secret closely guarded for years but, in 1867, Nobel of Swe-

den effectively desensitized nitroglycerin and in 1875 brought forth the explosive known today as gelatin dynamite.

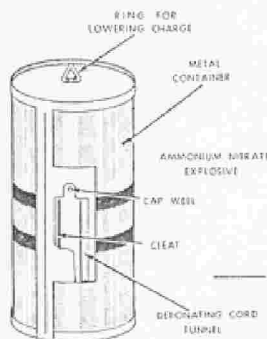
Glycerin is a by-product of soap manufacture but when treated with sulphuric and nitric acids becomes nitroglycerin.

Nitroglycerin is an oily liquid which is colorless when pure but, because of impurities, is often found to be milky to yellow in color.

Nitroglycerin is the most commonly used explosive in safe-blowing operations. It is a liquid with an extremely high speed of detonation (29,000 FPS) and hence is probably one of the most effecting explosives, outside of military types for shearing steel in safe cracking operations, etc.

Nitroglycerin is a most dangerous liquid and can explode — apparently spontaneously — from such causes as a slight jar, over-

-46

heating, chemical reaction with container materials, or impurities from storage. In certain cases, it has been known to detonate for no apparent reason at all.

As manufactured, nitroglycerin is usually found in dynamites in the percentages of between 10-60 per cent and is usually the source for criminals to obtain their pure (crude) "milled" nitro for safe blowing operations.

Pure nitroglycerin is seldom used by industry and then only by certain larger petroleum companies for fracturing formations in oil or gas wells.

The criminal has these possible sources for obtaining nitroglycerin:

1. Stolen from oil company storage areas or dynamite manufacturing companies (difficult, however, because of security measures).
2. Crude methods of extracting from high grades 40-60 per cent dynamite. Several methods of extracting have been used:

- a. Heating the dynamite on a steel plate over an open fire and spooning off the collected nitro-residue (*most hazardous!!!*).

- b. By heated salt solutions.

- c. By "milking" the nitroglycerin in a silk stocking under hot water. The silk stocking method produces the best grade and nitro produced by this method is usually a pale brown in color. It should be remembered that nitroglycerin produced in this manner is extremely sensitive, due to the impurities in the liquid.

- d. The criminal may also manufacture nitroglycerin by the direct nitration of glycerin using chemical methods and laboratory conditions. Nitro so made is usually water white in color and samples found usually contain a layer of water above the nitroglycerin. This type of nitro is also super-sensitive because amateur manufacturers seldom do a good job of washing out acid impurities.

- e. By boiling dynamite in water and skimming.

It should be noted that criminals seldom carry their nitro under safe conditions and frequent accidents do occur. A point

-47

worth noting also is that, contrary to previous teachings, frozen nitroglycerin is not as sensitive as the liquid material and, once frozen, it can be transported as easily as liquid. In other words, frozen nitroglycerin is not as hypersensitive as previously thought. Semifrozen, however, it is very sensitive because of a change in chemical composition.

Nitroglycerin is a powerful heart stimulant. It has a sweet taste, but one small taste will cause a severe headache. Prolonged breathing of the vapors or contact with the skin can be dangerous

so, should this happen, seek medical attention.

### Detection of Nitroglycerin

Several methods have been used by various officials for the detection of nitroglycerin. They are:

1. **The anvil or hammer method**—Take a piece of newspaper,  $\frac{1}{4}$  inch wide by approximately 4 inches long, and dip one end into the nitroglycerin about  $\frac{1}{4}$  inch up on the paper and slightly saturated. Withdraw the strip and lay it on an anvil or solid steel object. Using a wooden shield or other similar face protector, take a hammer and strike the saturated tip of the newspaper. If it is nitro, it will give a resounding sharp report similar to a firecracker exploding.

2. **Burning technique for detection**—The newspaper strip method may also be used for detection. Cut a strip of newspaper,  $\frac{1}{4}$  inch wide by about 8 inches long, and saturate the end about  $\frac{3}{4}$  inches up by dipping. Light the dry end of the newspaper and retire to a safe distance. If it is nitroglycerin, the paper will burn with a bright yellow or greenish tint and will have a crackling sound. In some cases, it may explode with a sharp report.

3. **Laboratory analysis**—Procure about five or six drops in a small plastic container as the lab technician will require that much (if you can find a technician willing to run the test).

### Neutralization Techniques for Nitroglycerin

Several solutions can be prepared for neutralizing or desensitizing nitroglycerin, these being:

1. **Alcoholic potash solution**—A solution of potassium hydroxide in denatured alcohol or methanol. The strength should be about 10 per cent or 10 grams per 100 cc, although a stronger solution may be carried to the site and diluted before use. When adding the neutralizer, be sure and do it slowly! For the amounts of nitroglycerin to neutralize, use about five parts neutralizer to one part nitroglycerin, or more if desired.

2. **Nitroglycerin destroyer, No. 1.**—  
Sodium sulphide: 77 parts  
Denatured alcohol: 54 (Antifreeze grade) parts  
Acetone: 16 parts  
Water: 23 parts

3. **Nitroglycerin destroyer, No. 2.**—  
1 quart water  
 $3\frac{1}{2}$  quarts denatured alcohol  
1 quart acetone  
1 pound of 60 per cent sodium sulfide  
(Blot or scrub carefully)

In addition to the above mixtures: two separate containers, one containing one pint of methanol and one with one pint of acetone should be kept in the neutralizing kit for flushing and finishing operations on safe jobs.

4. **Simple nitro neutralizing solution**—Ethyl alcohol: Seventy parts by weight and acetone: 20 parts by weight.

Any of the above three mixtures can be used in the desensitizing operations of nitroglycerin or flushing operations in safe-cracking failures, but the residue should be collected in containers and eventually poured into sawdust for complete destruction by burning in a disposal area.

### Handling Techniques

First of all, do not drop nitroglycerin or throw it against a wall. The experts say that such tactics would result in a detonation about 50 per cent of the time.

Containers used should be made of plastic or rubber materials and well cushioned. A good practice is to carefully pour the nitro into a sawdust-filled container prior to transporting. You

are now in effect converting it to a low grade dynamite prior to transporting.

The best method is to use the neutralizing solution prior to transporting but, in the absence of this solution, try to avoid carrying the nitroglycerin in its original container.

Extreme heat could affect the sensitivity of nitroglycerin. So, on an extremely hot day, it would be wise to cool the nitro to a normal temperature while transporting.

If you should spill a little nitro on the floor, don't panic. Either use a neutralizer or absorb the nitroglycerin into a handful of sawdust and place this in the container. If a standard neutralizer is not available, ethyl alcohol soaked into the nitro will help somewhat to desensitize the liquid.

### Disposal Techniques

1. **Pure nitro**—Either by detonation or by burning. If it is to be burned, it should be poured on a bed of sawdust and a 25-foot ignition train used.

2. **Desensitized nitro waste**—By burning on a bed of sawdust, still observing the 25-foot ignition train rules.

It is not advisable to dump nitroglycerin into a fast moving stream, as dangerous quantities could collect at various points presenting a future hazard.

3. **Badly decomposed nitroglycerin**—Note: should you ever be called in to handle a vial, glass, or container of nitroglycerin, it may be extremely hazardous to transport because of a bad state of decomposition. As nitro decomposes, it becomes more acid in state and may explode violently at the slightest jar or increase of heat. Badly decomposed nitro will cause reddish brown fumes to evolve at the top of the liquid. Should you ever see these types of fumes, it would be advisable to add nitroglycerin destroyer remotely and under no circumstances transport for any great distance as, in this state, it is unpredictable.

### MILITARY AND FOREIGN EXPLOSIVES

Most military explosives encountered by peace officers will be in the form of very brisant high explosives whether in muni-

tions or in bulk form. In addition, most military bulk explosives are relatively insensitive to heat, shock, or friction because of the high military specifications.

They are not encountered in bulk form too often because of the stringent regulations on most stations and the security of military magazine areas. The detection of a military explosive if used, however, will not be too difficult because it will have a very marked shattering effect based upon their rates of detonation (23,000 feet per second in most cases). Another unique feature of military explosives is the requirement of a special type of blasting cap called "the engineer special cap" for initiation or detonation of the explosive.

Due to the insensitive nature of military explosives the cap must be stronger to affect a detonation. Most commercial caps (No. 6 etc.) will not detonate military high explosives.

The following charts will outline the major types of military and foreign explosives. Many military bomb disposal units are capable of identifying explosives both by chemical analysis and by visual inspection. Therefore, if a doubt exists, seek aid from a local army military unit.



**MILITARY LOW EXPLOSIVES**

**NAME:** Single base propellant (nitrocellulose explosives).  
**COLOR:** Amber, brown, or black.  
**TYPE:** Low explosive.  
**DETONATING TEMPERATURE:** Ignites at 350°C, but will detonate if heated in large quantities.  
**LOADING METHODS:** Cast or poured.  
**SENSITIVITY:** Sensitive to heat, shock, or friction.  
**USE:** Propellant.  
**INITIATION REQUIRED:** Flame, spark, or detonator with booster.  
**REACTION WITH METALS:** Slightly evolves acetal.  
**DISPOSAL:** By burning.  
**REMARKS:** Single base propellants are normally used by the military as a propelling charge in artillery types of weapons to propel the projectile to its target.

**MILITARY LOW EXPLOSIVES**

**NAME:** Double base propellants.  
**COLOR:** Grey green to black.  
**TYPE:** Low explosive.  
**DETONATING TEMPERATURES:** Ignites at 130°C and will detonate if heated in large quantities.  
**LOADING METHODS:** Cast.  
**SENSITIVITY:** Very sensitive to heat, shock, or friction.  
**USE:** PROPELLANT

51

**INITIATION REQUIRED:** Flame, spark, or detonator.  
**REACTION WITH METALS:**  
**DISPOSAL:** By burning.

**REMARKS:** Double base propellants are normally used as the solid fuel for large rocket motors or boosters. These propellants use nitroglycerin as a solvent in the manufacturing process and are therefore more sensitive and dangerous than single base propellants. They will detonate violently if a blasting cap and booster are applied.

**PRIMARY HIGH EXPLOSIVES**

Primary high explosives are those extremely sensitive to heat, shock, and friction. Because of their sensitive nature and extremely brisant (shocking) nature, they are used in primers where, by shock or friction, they produce fire for ignition purposes and in detonators or blasting caps where, by friction or percussion, they produce a detonating wave (shock) to initiate high explosives (boosters and main charges).

It might be interesting to note that they are also used in the manufacture of toy caps, toy torpedoes, cherry bombs, and the like to produce noise for children. Many times commercial fireworks are used as a source to obtain large charges of improvised explosives by psychotics.

The most sensitive of the primary high explosives is an explosive called "fulminate of silver." It is prepared by a solution of nitrate of silver precipitated by lime water and treated with a strong solution of ammonia. The dry residue of fulminate of silver is so sensitive that, in most cases, it will explode when touched. This is the best example of why we say that an explosive is an unstable substance always trying to become stable. The following charts will best illustrate the major primary high explosives in use by military and foreign countries today.

**PRIMARY HIGH EXPLOSIVES**

**NAME:** Mercury fulminate  
**COLOR:** Grey  
**TYPE:** Primary high explosive  
**DETONATING TEMPERATURE:** 180°C (356°F)  
**LOADING METHODS:** Pressed  
**SENSITIVITY:** Very sensitive to heat, shock, and friction  
**USE:** Initiators, blasting caps, etc.  
**INITIATION REQUIRED:** Blunt or sharp striker, spark, or flame  
**REACTION WITH METALS:** Very little  
**DISPOSAL:** By detonation  
**REMARKS:** At one time was used primarily in detonators and blasting caps but is slowly being phased out today with lead azide.

-52

**PRIMARY HIGH EXPLOSIVES**

**NAME:** Lead azide  
**COLOR:** Grey  
**TYPE:** Primary high explosive  
**DETONATING TEMPERATURE:** 350°C  
**LOADING METHODS:** Pressed  
**SENSITIVITY:** Very sensitive, but less sensitive than mercury fulminate  
**USE:** Detonators, blasting caps, and assorted initiators

**INITIATION REQUIRED:** Flame, or stab strikers  
**REACTION WITH METALS:** Very little  
**DISPOSAL:** By detonation  
**REMARKS:** Used considerably in military detonators and blasting caps.

**PRIMARY HIGH EXPLOSIVES**

**NAME:** Lead styphnate  
**COLOR:** Stark to yellow  
**TYPE:** Primary high explosive  
**DETONATING TEMPERATURE:** 267°C  
**LOADING METHODS:** Pressed  
**SENSITIVITY:** Very sensitive to flame, or percussion  
**USE:** Initiator  
**INITIATION REQUIRED:** Flame, or percussion  
**REACTION WITH METALS:** Very little  
**DISPOSAL:** By detonation  
**REMARKS:** Used primarily to make an initiator more sensitive to percussion. Often used in conjunction with a pellet of lead azide. Considered to be a poor initiator as it cannot be used alone.

**SECONDARY HIGH EXPLOSIVES**

**NAME:** P.E.T.N.  
**COLOR:** White  
**TYPE:** Secondary high explosive  
**DETONATING TEMPERATURE:** 210°C  
**LOADING METHODS:** Pressed and often mixed with wax  
**SENSITIVITY:** Quite sensitive, if used alone  
**USE:** Small caliber high explosive shells and detonating cord  
**INITIATION REQUIRED:** Detonator  
**REACTION WITH METALS:** Very little  
**DISPOSAL:** By burning or detonation  
**REMARKS:** The most common use of P.E.T.N. is in commercial detonating cord (previously). A very brisant high explosive that detonates at 8,300 meters per second.

**SECONDARY HIGH EXPLOSIVES (Boosters)**

**NAME:** Tetryl  
**COLOR:** Yellow  
**TYPE:** Secondary high explosive  
**DETONATING TEMPERATURE:** 260°C  
**LOADING METHODS:** Pressed  
**SENSITIVITY:** Fairly sensitive, and will detonate from the shock of a rifle bullet  
**USE:** Booster explosive  
**INITIATION REQUIRED:** Detonator  
**REACTION WITH METALS:** Very little

53

**DISPOSAL:** By burning or detonation  
**REMARKS:** Widely used in military munitions as a booster explosive, and in small land mines as a main charge, because of its great shattering effect.

**SECONDARY HIGH EXPLOSIVE**

**NAME:** R.D.X.  
**COLOR:** White  
**TYPE:** Secondary high explosive  
**DETONATING TEMPERATURE:** 197°C  
**LOADING METHODS:** Pressed or cast  
**SENSITIVITY:** Very sensitive to bullet impact or shock  
**USE:** As a booster or when mixed as a main charge  
**INITIATION REQUIRED:** Detonator  
**REACTION WITH METALS:** No reaction  
**DISPOSAL:** By burning or detonation  
**REMARKS:** R.D.X. has the highest rate of detonation known (9,300 meters per second), therefore, is considered the most powerful explosive known. It is widely used by many countries as a booster and main charge explosive.

**MAIN CHARGE HIGH EXPLOSIVE**

3

FIGURE 27. TNT - One-half and one pound blocks.

Because of high military specifications, this group is considered to be relatively insensitive to heat shock and friction. Therefore, the majority require a special type of blasting cap (high powered) to initiate a detonation. They are, however, very brisant and are very suitable as a main charge explosive in artillery projectiles, land mines, warheads, grenades, and aircraft bombs.

54

Most civilian or commercial concerns do not utilize military high explosives in bulk form because of their high cost. When peace officers encounter military high explosives, they can be traced to a military source. Of the majority of military explosives encountered, I would say TNT (trinitro-toluene) and the composition (plastic) explosive groups are in use.

The following charts will best describe the explosive properties of most military and foreign main charge explosives in use today.

#### HIGH EXPLOSIVES (Main Charge)

NAME: T.N.T. (trinitro toluene)  
 COLOR: Straw (brown if deteriorated)  
 TYPE: High explosive  
 DETONATING TEMPERATURE: 470°C  
 LOADING METHODS: Cast or pressed—sometimes flaked  
 SENSITIVITY: Insensitive to heat, shock, or friction  
 USE: Main charge  
 INITIATION REQUIRED: Engages special blasting cap  
 REACTION WITH METALS: None—reacts with alkalis  
 DISPOSAL: By detonation or burning  
 REMARKS: Perhaps the most widely used military explosive both United States and foreign. It is also mixed in many forms to create other explosive mixes. A very brisant (shattering explosive) with a detonating rate of 6,500 meters per second.

#### HIGH EXPLOSIVES (Main Charge)

NAME: E. C. blank powder  
 COLOR: Orange or pink  
 TYPE: High explosive  
 DETONATING TEMPERATURE: 200°C  
 LOADING METHODS: Powdered  
 SENSITIVITY: Extremely sensitive to heat, shock, and friction  
 USE: Blank ammunition—main charge  
 INITIATION REQUIRED: Spark—detonator flame  
 REACTION WITH METALS: Reacts with copper, magnesium, and steel  
 DISPOSAL: By burning or detonation  
 REMARKS: The name "E. C. powder" is an abbreviation for Explosives Company Powder since it was invented by the Explosives Company at Stoneham in England. It was one of the first nitrocellulose explosives to be developed. It may also be considered as a propellant but is sensitive enough if confined to be classed among the high explosive family.

#### HIGH EXPLOSIVES (Main Charge)

NAME: Amatol  
 COLOR: Straw to white  
 TYPE: High explosive  
 DETONATING TEMPERATURE:  
 LOADING METHODS: Extrusion or cast  
 SENSITIVITY: Less sensitive than TNT

55

#### HIGH EXPLOSIVES (Main Charge)

USE: Main filler in Japanese bombs.  
 INITIATION REQUIRED: Detonator  
 REACTION WITH METALS: Forms dangerous salts with tin and copper  
 DISPOSAL: By burning or detonation  
 REMARKS: Used in U.S. Bangalore torpedoes and Japanese munitions. In certain cases, amatol was used in conjunction with TNT as a substitute explosive. If these two combinations set together over a period of years, a dangerous gas pocket is formed which requires special handling in a spontaneous ignition or detonation may occur.

NAME: Ammonium nitrate  
 COLOR: Colorless  
 TYPE: High explosive  
 DETONATING TEMPERATURE: Ignites at 605°C  
 LOADING METHODS: Cast or press  
 SENSITIVITY: Relatively insensitive unless formed with metals or moisture  
 USE: Cratering charge, propellant, etc.  
 INITIATION REQUIRED: Detonator or igniter  
 REACTION WITH METALS: Yes, with iron, steel, copper, brass, lead, and cadmium  
 DISPOSAL: By burning or detonation  
 REMARKS: Ammonium nitrate is used as an explosive and a fertilizer commercially. The purity as a fertilizer does not have to meet the high requirements of an explosive. However, ammonium nitrate in any grade desensitized with a fuel oil and a proper booster can be detonated with violent results.

#### HIGH EXPLOSIVES (Main Charge)

NAME: Composition "B"  
 COLOR: Dirty white to brownish yellow  
 TYPE: High explosive  
 DETONATING TEMPERATURE: 270°C  
 LOADING METHODS: Cast  
 SENSITIVITY: Relatively insensitive  
 USE: Main charge  
 INITIATION REQUIRED: Detonator  
 REACTION WITH METALS: Mild  
 DISPOSAL: By detonation or burning  
 REMARKS: Composition "B" today is rapidly replacing TNT as a standard main charge high explosive in military munitions. Main body consists of TNT-RDX and wax. Composition "B" however is more sensitive from a disposal standpoint than TNT.

#### HIGH EXPLOSIVES (Main Charge)

NAME: Composition C-3 (plastic explosive)  
 COLOR: Yellowish, hand tamped, puttylike explosive.  
 TYPE: High explosive  
 DETONATING TEMPERATURE: 280°C  
 LOADING METHODS: Packed or pressed  
 SENSITIVITY: Relatively insensitive  
 USE: Demolition blocks, ILEP rounds, mines.  
 INITIATION REQUIRED: Detonator  
 REACTION WITH METALS: Mild

56

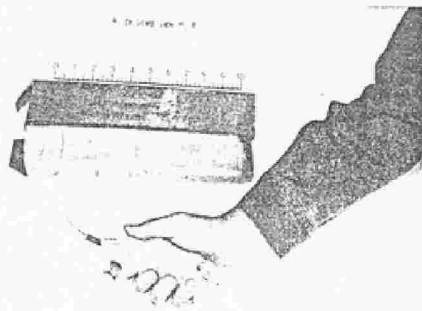

FIGURE 28. Plastic explosive C-3.

DISPOSAL: By detonation or burning  
 REMARKS: Perhaps one of the most widely used high explosives in hand disposal personnel because of its plastic qualities. A very brisant, efficient high explosive indeed.

#### HIGH EXPLOSIVES (Main Charge)

NAME: Composition C-4 (plastic explosive)  
 COLOR: Dirty white to light brown  
 TYPE: High explosive  
 DETONATING TEMPERATURE: 290°C  
 LOADING METHODS: Packed or pressed  
 SENSITIVITY: Relatively insensitive  
 USE: Demolition blocks—underwater demolition  
 INITIATION REQUIRED: Detonator  
 REACTION WITH METALS: Mild  
 DISPOSAL: By burning or detonation  
 REMARKS: Widely used by military demolition personnel but becomes brittle in cold weather. Therefore, C-4 is more widely used as a plastic explosive.

#### HIGH EXPLOSIVES (Main Charge)

NAME: Explosive "D" (ammonium picrate)  
 COLOR: Orange or lemon yellow  
 TYPE: High explosive  
 DETONATING TEMPERATURE: 325°C  
 LOADING METHODS: Pressed  
 SENSITIVITY: Very insensitive  
 USE: Main charge in armor piercing rounds  
 INITIATION REQUIRED: Detonator  
 REACTION WITH METALS: Reacts with metals to form sensitive salts  
 DISPOSAL: By burning or detonation  
 REMARKS: This explosive is inferior in strength to TNT but is widely used in military armor piercing munitions because of its insensitive qualities to heat, shock, or friction.

57

#### HIGH EXPLOSIVES (Main Charge)

NAME: HBX-1  
 COLOR: Gray  
 TYPE: High explosive  
 DETONATING TEMPERATURE: 250°C  
 LOADING METHODS: Cast  
 SENSITIVITY: Relatively insensitive

USE: Depth charges, torpedo warheads, rocket warheads

INITIATION REQUIRED: Detonator

REACTION WITH METALS: No apparent serious reaction

DISPOSAL: By detonation or burning

REMARKS: This explosive consists of RDX, TNT and aluminum. The aluminum is added in many explosives used underwater to give extra heat, and shock to the explosion. This explosive cannot be steamed. It detonates at a rate of 2,000 meters per second and is considered to be a high brisance explosive.

#### HIGH EXPLOSIVES (Main Charge)

NAME: Nitrostarch

COLOR: Grey

TYPE: High explosive

DETONATING TEMPERATURE: 217°C

LOADING METHODS: Pressed

SENSITIVITY: More sensitive than TNT and will detonate on bullet impact

USE: Grenading charge

INITIATION REQUIRED: Detonator or bullet impact

REACTION WITH METALS: Will corrode metals

DISPOSAL: By burning or detonation

REMARKS: Nitrostarch consists of a nitrated starch which is fairly hygroscopic (absorbs moisture), because of its sensitivity it should never be broken or crumbled.

#### HIGH EXPLOSIVES (Main Charge)

NAME: Picric acid

COLOR: Yellow

TYPE: High explosive

DETONATING TEMPERATURE: 250°C for 5 seconds

LOADING METHODS: Pressed or cast

SENSITIVITY: Rather sensitive, similar to a booster explosive

USE: Japanese main charge and German booster

INITIATION REQUIRED: Detonator

REACTION WITH METALS: Forms sensitive salts - dangerous

DISPOSAL: By burning or detonation

REMARKS: Picric acid can be neutralized by a sodium carbonate or sodium sulfite solution. It may be toxic to certain personnel on skin contact. If mixed in water, it will impart a yellow color to the solution.

Picric acid crystals have been purchased from drug supplies and have been used for terrorists who achieved a detonation by using an incinerator to acquire the detonating temperature.

#### HIGH EXPLOSIVES (Main Charge)

NAME: Gunotton

COLOR: White

TYPE: High explosive

DETONATING TEMPERATURE: Ignites at 200°C

LOADING METHODS: Pressed

78

SENSITIVITY: Very sensitive to heat, shock, and friction

USE: Primers, smokeless propellants, and general demolition work

INITIATION REQUIRED: Detonator

REACTION WITH METALS: None

DISPOSAL: By burning or detonation

REMARKS: This explosive is made by treating cotton with nitric and sulfuric acids. There are recorded cases of unfortunates attempting to manufacture this explosive by the above method. Gunotton is still used today by Great Britain and Canada as a demolition explosive. Gunotton is soluble in acetone.

#### HIGH EXPLOSIVES (Main Charge)

NAME: Military dynamite

COLOR: Buff and pink

TYPE: High explosive

DETONATING TEMPERATURE: Unknown

LOADING METHODS: Machine tamped

SENSITIVITY: Rather insensitive

USE: Blasting and quarrying

INITIATION REQUIRED: Detonator

REACTION WITH METALS: Unknown

DISPOSAL: By burning or detonation

REMARKS: One of the newer military explosives, used in low velocity and medium velocity grades. It is relatively insensitive to heat, shock, or friction as compared to commercial straight dynamite, and has a fast rate of detonation (1,257 meters per second). This would be about half as fast as TNT.

#### HIGH EXPLOSIVES (Main Charge)

NAME: Liquid oxygen (LOX)

COLOR: Clear liquid

TYPE: High explosive

DETONATING TEMPERATURE: Unknown but low

LOADING METHODS: Pressed in liquid form

SENSITIVITY: Very sensitive to heat, shock, and friction

USE: Above ground mining

INITIATION REQUIRED: Spark, heat or detonator

REACTION WITH METALS: Unknown

DISPOSAL: By detonation

REMARKS: Liquid oxygen is used considerably by Hungary and Russia as an above ground explosive. When mixed with a porous material such as lamp black, it becomes a very brisant high explosive. Liquid oxygen is very dangerous as it becomes violent on contact with grease or oils.

#### HIGH EXPLOSIVES (Main Charge)

NAME: Photo-flash powder (often considered pyrotechnic)

COLOR: Silver to grey

TYPE: Pyrotechnic, but highly explosive

DETONATING TEMPERATURE: Very low

LOADING METHODS: Powder

SENSITIVITY: Extremely sensitive to heat, shock, or friction

USE: Military fireworks, night photography, etc.

INITIATION REQUIRED: Spark, flame, friction, or detonator

REACTION WITH METALS: Unknown

DISPOSAL: By detonation or burning

REMARKS: Although photoflash powder is considered to be a pyrotechnic item,

79

I prefer to class it among the very sensitive high explosives because of its violent nature. Photoflash powder has been used by psychotic bombers and explodes with all the violence of a true high explosive. Photoflash consists of a mixture of barium nitrate, aluminum powder, and potassium perchlorate. Handle with care!

#### SHEET EXPLOSIVES (EL-506 DU PONT)

Sheet explosives are among the most recent developments in the high explosive field and are considered to be the most versatile. They can be molded by wrapping, or shaped to cut any type of hole and their flexibility resembles a rubber matting.

To date, I have seen the colors range from pink to green, and the detonating rate ranges up to 7500 meters per second, indicating a very brisant high explosive, indeed.

The initiation required for sheet explosives is a special blasting cap (engineers type because of the relative insensitivity of sheet explosive to heat, shock, or friction).

The thickness of sheet explosives ranges from 0.084 inches to almost one-half inch. I feel that sheet explosives for disposal work will eventually take their place as a leader. However, we should bear in mind that they can also be used in a clandestine device as small as an envelope.

The advantages of sheet explosive as a cutting charge and pliable worker should most certainly be considered for any demolition operation. In the past, we have relied on a plastic (putty type) explosive, but the science of Du Pont has now created a total wrap-around sheet explosive which will do many jobs with tremendous power (Figure 29).

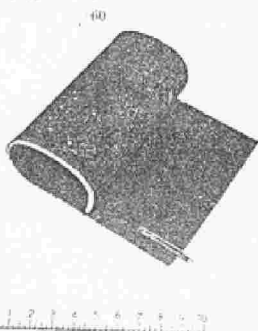

Figure 29. Sheet explosive (pliable).

#### LIQUID EXPLOSIVES

Liquid explosive is a recent development but, at present, not too much is known about its capabilities or limitations. It consists basically of two liquids inert when separated, but active and highly explosive when mixed. It would appear that this type of explosive would also be very versatile when perfected.

#### HOME MADE AND IMPROVISED EXPLOSIVES

Many law officers are totally unaware of the ease with which a basic chemistry student can construct a bomb or like device

using homemade or backyard explosives.

The only ingredients required are a fuel, a good oxidizer, and binder.

A drugstore or drug supply in most cases can furnish various oxidizers such as chlorates, perchlorates, and nitrates and the fuels can be procured in any "dime" store.

When confined and properly initiated, these crudely improvised explosives can explode with fantastically violent proportions.

The most widely used explosives in the improvised group seem to be black powder and smokeless powder. These two explosives

61

are easy to buy commercially in any gun shop for reloading purposes, or black powder can be manufactured from chemicals procured in any hobby shop. The majority of major gun shops sell various smokeless powders in one pound cans (Figure 30).



FIGURE 30. Rifle sporting powder (smokeless).

Black powder manufactured in secrecy usually consists of the following ingredients: potassium nitrate, 74%; powdered charcoal, 16%; sulphur, 10%.

Black powder, in the ratio shown, is mixed in dry or in paste form, screened, and dried. When confined and ignited with a spark or brisk flame, it will cause its container to burst violently. Because of its low velocity, the container will usually be found in large chunks over a wide radius.

Smokeless powder (commercial grade) will explode at a faster burning rate than black powder, if confined.

Other improvised mixtures and sources of homemade explosives are as follows:

1. Nitroglycerin (extruded from dynamite).
2. Mixtures of potassium chlorate and powdered or granulated sugar.
3. Mixtures of potassium nitrate, ammonium nitrate, and charcoal.
4. Potassium perchlorate mixtures.
5. Mixtures of potassium chlorate and red phosphorous.
6. Potassium chlorate and vaseline.
7. Model airplane glue (confined).
8. Common country store match heads (tips only).
9. Ammonium nitrate prills (fertilizer) with No. 2 fuel oil.
10. Liquid oxygen and lampblack or spongy material.
11. Calcium carbide with water.
12. Chinese firecracker powder.
13. Toy cherry bomb powder.

62

14. Flashlight powder procured in camera and photography supply houses.
15. Common match heads nitrated with urine and dry processed.
16. Toy perforated roll caps in bulk.
17. Acetone, confined.
18. Ether, confined.
19. Mixtures of potassium chlorate or sodium chlorate with wax.
20. Mixtures of sodium chlorate and sugar.
21. Mixtures of potassium carbonate and picric acid in crystal form.
22. Mixtures of oxidizers and wood putty.

The majority of mixtures shown above can be initiated by a spark or flame, but some will require a detonator to propagate a detonating wave. These are by no means all of the mixtures, but show a good cross section.

65

#### MISCELLANEOUS IMPROVISED EXPLOSIVE DEVICES

1. Propane or butane tanks.
2. Dust explosives, flour, starch, or coal dust initiated with a burster igniter (Figure 31).
3. Natural gas stove jets opened and a candle placed at floor level.



FIGURE 31. Calcium carbide as sold in toy and hobby shops.

#### DISPOSAL OF EXPLOSIVES

There are a number of methods used to remove explosives from their containers such as unpanning, thermal (steaming), and chemical (solvent means). However, the actual disposal phase is most important toward completely disposing of the hazard of a high or low explosive.

The methods which are considered most effective for disposal of high and low explosives are: dumping at sea, detonation, burning, and dumping in a fast moving stream.

For chemical and military munitions, a nearby military explosive ordnance disposal team should be contacted as these munitions (depending upon the type) are extremely hazardous to dispose of without the proper equipment. Following are general disposal methods to be used for high explosives.

#### Methods of Removing Explosives from Containers

1. **Steaming**—Certain explosives may be steamed from their containers using low pressure controlled temperature steam. However, certain hazards exist during this operation and before steaming the type of explosive should be known.

Explosives containing mixtures of ammonium nitrate, TNT and aluminum powder will detonate if steamed. RDX and composition "A" may also detonate if steamed. It must be stressed

64

that this technique is not a disposal method as the residue and sludge from steaming are still highly explosive. The procedures listed here are only methods of removing certain explosives from containers; such as TNT, etc.

2. **Chemical**—Certain solvents may be employed to dissolve certain explosives from their containers such as:

- Water—black powder, ammonium nitrate.
- Pyridine—mercury fulminate.
- Phenol—RDX.
- Acetone—will dissolve the majority of remaining explosives.

### Actual Disposal Operations

1. **Dumping at sea**—All explosives may be disposed of by dumping at sea. Regulations require that the explosives be removed from their containers and dumped not less than ten miles from shore at depths of not less than 500 fathoms. Regulations may vary on this procedure depending upon buoyancy of certain explosives.

2. **Detonation**—Most explosives can be primed and detonated, if a proper disposal area exists, and if the various types of explosives are prepared in the proper manner.

Primary high explosives, in bulk, in cloth bags, may be primed and detonated. However, small metallic blasting caps, detonators, and primers should be detonated in small quantities to insure complete detonation.

3. **Burning of explosives**—Burning is generally considered to be the preferred method of destroying bulk high explosives. During a burning operation, one should always stand by for a high order detonation and never burn more explosives than the surrounding area can stand should it detonate in mass.

Explosives are burned in layers not more than three inches thick on a bed of combustible material, such as excelsior. To ignite the explosive bed, use a 25-foot ignition train or one long enough for the person igniting it to reach a safe area before the explosives ignite. Certain limits of explosive weights should be observed during burning operations, such as:

#### a. Black powder:

Do not burn more than fifty pounds at one time and spread the powder in a train two to three inches wide, using care not to have any part of the train closer to any other than ten feet. Using a 25-foot ignition train, burn the powder in the direction from which the wind is blowing. Black powder may also be dumped into a fast moving stream.

#### b. Smokeless powder (blank, shotgun, etc.):

Burn no more than 2,000 pounds at one time and spread in a train about four feet wide, six inches deep and fifty feet long. If rocket grains (solid propellant) are burned, they should not be stacked nor left in containers. Row let grains must be burned in single layers. Again, the 25-foot ignition train rule applies.

#### c. Booster and main charge explosives:

These explosives are spread in a layer not more than three inches thick and burn no more at one time than the area can stand should it detonate. The 25-foot ignition rule again is used.

#### d. Dynamites:

Burn no more than 100 pounds at one time. The cartridges should be slit lengthwise and placed in a single layer, not greater in width than the length of one cartridge, on a bed of combustibles. If dynamite shows signs of exuding (bleeding), it should be burned in the unopened container. Always stand by for a detonation as dynamite is quite sensitive to burning. Observe the 25-foot ignition train rule.

#### e. Nitroglycerin (liquid):

Raw or liquid nitroglycerin may be burned by soaking it into sawdust and burning on a bed of combustibles. One should not burn more than one pint (soaked in sawdust) at one

time and should carefully spread the sawdust out of the ground two inches deep prior to pouring the nitro in small quantities. Never mix or agitate the nitro in sawdust. Due to the extreme sensitivity of this mixture, the chances of it detonating are quite probable. Chemical breakdown or straight detonation are perhaps more desirable methods.

66

### IMPROVISED EXPLOSIVES DISPOSAL

Most improvised explosives can be disposed of by burning, much the same as any high explosive. However, there are certain hazards involved which require the use of common sense before the disposal operation.

I would say that the majority of improvised explosives can be burned using the 25-foot ignition train precaution, due to the oxidizers and fuels used. However, certain improvised explosives may require detonation much the same as a primary or booster type explosive. Experience will be the best teacher governing disposal of this large group. If one uses the standard approach of "standing by" for a high order detonation in all burning operations, and if you take the precautions necessary for a violent explosion, no one should be injured in any disposal operation.

We have made statements throughout this manuscript that certain explosives can be burned or detonated, but we also stated that explosives are an unstable substance and can detonate under the right circumstances.

Just plain burning, even unconfined and in small quantities, could cause an explosive to become stable by its violent detonation or explosion. *They are unpredictable* and should be treated as such.

67

### EXPLOSIVE SOLVENTS

A large number of explosives are soluble in certain solvents and in certain instances these solvents are used to soften and facilitate removal of the explosives from various containers. Acetone is a good example of a solvent which will soften or dissolve nearly all cast explosives. The following chart lists the major explosives and their solvents.

EXPLOSIVE	SOLVENT
Black powder	Water
Smokeless powder	Acetone
Fulminate of mercury	Alcohol, Ammonia, Pyridine
Lead azide	Acetone
Lead styphnate	Acetone
Tetryl	Acetone, Benzene
RDX	Acetone, Phenol
Picric acid	Alcohol, Acetone
PEEN	Acetone
TNT	Alcohol, Ether, Acetone
Amatol	Acetone
Composition G-3	Acetone
Peritolin	Acetone
Ammonium nitrate	Acetone, Water
Tetryl	Acetone
Nitroglycerin	Acetone, Alcohol, Benzene
Dynamite	Acetone, Alcohol
Nitro-starch	Acetone
Composition G-4	Acetone

### Chapter V

### EXPLOSIVE EFFECTS

IN nearly all explosions or detonations there are certain fundamental effects such as:

1. **Blast**—A positive pressure wave of compressed air which moves outward at a velocity of about 1110 feet per second. Pressures may reach 1,000,000 pounds per square inch.

2. **Heat** — Temperatures of 3000-4000°C are not uncommon and if metals are present, the white hot fragments will normally start fires.
3. **Fragmentation** — Container material or loose debris will move outward in every direction from the center of the blast wave and certain directional high velocity fragments may achieve speeds up to 20,000 feet per second.
4. **Earth shock** — If the explosion is located on or below the ground surface, a shock wave will move out similar to an earthquake and will break water or gas mains and crack foundations.
5. **Suction phase** — A negative pressure wave creating a vacuum effect will follow the fast-moving blast wave creating almost the same amount of damage as the initial compression wave.

### SPECIAL EXPLOSIVE EFFECTS

In 1799, during an experiment, a phenomenon was observed.

69

The shape of the explosion and its container would cause a directional or pin-pointing effect and this finding was exploited to the maximum during three major wars.

Science today has created directional explosive munitions capable of penetrating many inches of steel or many feet of reinforced concrete.

The effects in some cases resemble those of a magnifying glass placed above an object focusing the sun rays and intense heat to one focal point.

It is not difficult to see why the concentrated force of an explosive will penetrate deep into a solid object because, if one can pinpoint temperatures of 4,000°C, pressures of 1,000,000 pounds per inch, and velocities of 23,000 feet per second, something is going to give in its path.

Other explosive experiments with directional munitions indicated that a mild flexible steel object rather than brittle steel, if loosely attached to a high velocity explosive, would move outward at speeds of almost 80 per cent of the initial detonating rate, giving the effect of an ultra high speed projectile. This was a rather amazing discovery because previously it was thought that the plate would break up from the explosive force.

These special effects are not limited to the military because directional munitions have been employed already by safe crackers, terrorists, and saboteurs to better accomplish their destructive mission. The peace officer should familiarize himself with these effects and identify these types as they will have a great bearing on the method of transporting and disposal techniques. A directional munition could penetrate through a standard bomb carrier and travel unchecked for great distances at ultra-high velocities. These munitions will sometimes travel beyond normal expected fragmentation ranges and some go as far as 2,400 yards.

### FRAGMENTATION EFFECT

This effect has been used since very early munitions and consists basically of an explosive breaking up a steel casing or a serrated solid container by blast pressures. The fragments in this

70

case will normally move outward in all directions but could have some directional pattern, depending upon the placement of the container. Three examples are shown in Figure 32.

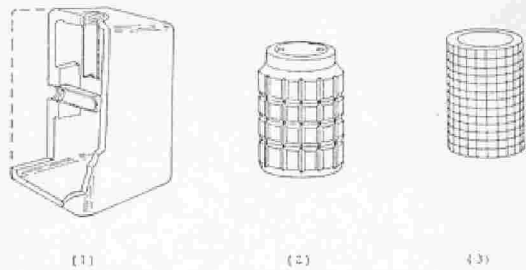

FIGURE 32. Fragmentation effect, internal charges. 1) Solid case, 2) Pressurized, 3) Wire wrapped.

### CAVITY AND SHAPE CHARGES (MUNROE-EFFECT)

A solid block of explosive placed on a steel object will normally produce some cavitation effect as shown in Figure 2, but the blast waves move outward in all directions, thereby losing the maximum pressure or force. Solid blocks of explosive when detonated will take the path of least resistance from the center of the explosion outward.



FIGURE 33. General cavitation effect with solid block of explosive, which leads to discovery of the "Munroe effect" (shape charge).

71

### EARLY CAVITY CHARGE EXPERIMENTS

In 1799, a Norwegian named Baader observed that if depressions or shapes were cut into an explosive and placed face down on a steel plate, the detonation would cause a distinct pattern to appear from the cavitation effect. (Figure 3)

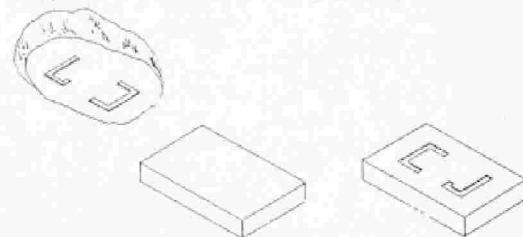

FIGURE 34. Early cavitation experiments by Baader.

In 1885, Charles Munroe at the Naval Torpedo Station in Alexandria, Virginia, conducted a series of experiments which perfected the cavity type of effect. His initial experiments using an inverted metal cone as a container for the explosive indicated great penetrating capabilities (Figure 4).

Munroe had made an amazing discovery. If two explosive surfaces are at an acute angle to each other and are simultaneously detonated; the shock wave, heat, and expanding gases from each surface will reinforce the other at the intersection point, forming a high velocity hot jet capable of deep penetration into steel or other hard materials.

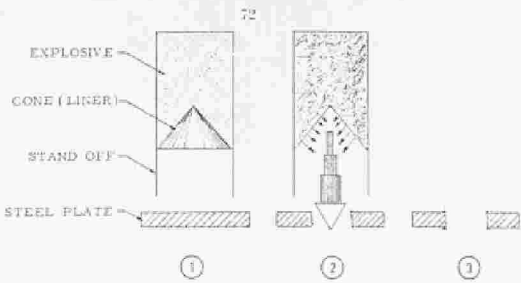

FIGURE 35. Charles Munroe experiments (Munroe shape charges). 1) Shape charge before detonation, 2) Shape charge during detonation and formation of the slug and jet, 3) After detonation, showing pin-point penetration.

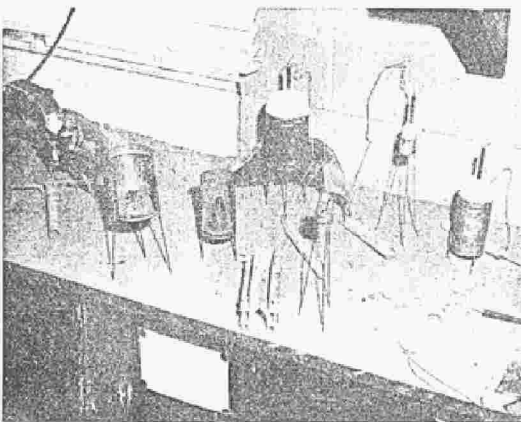
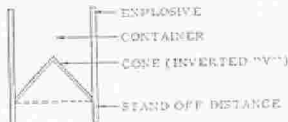

FIGURE 36. Assorted cavity and linear cutting charges.

72

LINEAR CUTTING CHARGES

Linear charges are designed for cutting steel objects rather than produce the pin-point effects observed in the Munroe shape charges. They consist of metallic containers which have been shaped with an inverted "V" at the base to create a cutting jet down the long axis of the charge on detonation. An end view of a linear charge would appear thus:



Any depression in a block of explosive will cause some degree of jet action, but the conical recess produces by far the strongest and most efficient jet. Munroe also discovered that, to obtain maximum penetration, the cavity container must be raised to various heights above the target, "stand off" distances, depending on the size of the container and explosive weight.

Any obstruction between the cone and target will cause a certain degree of deflection and break up of the jet action, reducing penetration. Many commercial firms today (steel and oil indus-

tries) use cavity charges. Therefore, their appearance in public is highly possible. There are recorded cases of shape charges being used in safe cracking operations.

74

MISNAY-SCHARDIN EFFECT (PLATE EFFECT)

This effect is often termed the high speed "plate" effect and consists of a mild steel plate loosely attached to the explosive which moves outward at fantastic speeds from the detonation. Certain plate devices have been known to penetrate as much as three inches of steel at distances as far as 100 yards from the detonating point. Figure 38 illustrates two versions of this effect. The plate, if properly initiated, will travel at speed of almost 70 per cent of the detonating rate, indicating speeds of 20,000 feet per second in certain cases.



FIGURE 38. Misnay-Schardin effect (plate charge). 1) Flat plate, 2) Concave plate.

75

CONCENTRATED BLAST EFFECT

Recent tests indicate that if a Munroe shape charge is placed directly against a steel object without using the stand off, deep penetration will not occur. However, the explosive force will be concentrated over a wide focal point giving a tremendous thrust against the object. This acts much like a large fist striking the object, giving fantastic power in a concentrated area (Figure 39).

76





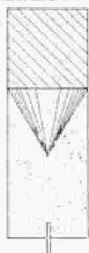

FIGURE 39. Concentrated blast effect. Slope charge applied directly to the target without using stand-off distance.

75

**FOUGASSE EFFECT (IMPROVED SHOTGUN)**

The fougasse or shotgun effect is an improvised directional munition constructed with pipe or tubing and is made very much like a shotgun shell. Incendiary devices much like the illustration shown have also been used on occasions.

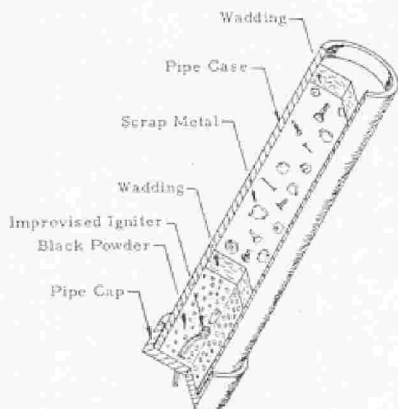
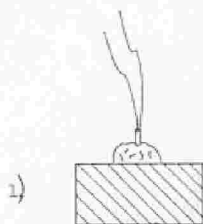

FIGURE 40. Fougasse (shotgun effect).

78

**SCABBING EFFECT**

This effect takes place when a large mass of explosive is detonated directly against the surface of a brittle steel target. The tremendous shock exerted against the face of the target will cause the opposite or reverse side of the target to flake or scab off large portions of metal and hurl the flakes at high speeds. In effect it cavitates the reverse side of the target.



1)

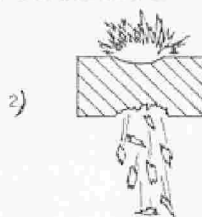

2)

FIGURE 41. Scabbing effect. 1) Plastic explosive placed directly against target. 2) Scabbing effect during detonation.

79

**SUB-MISSILE EFFECT**

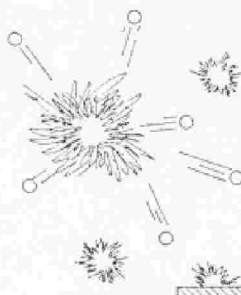
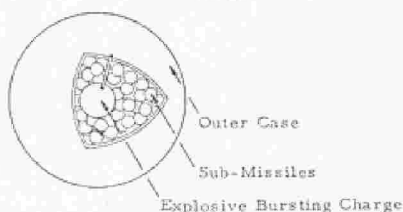

FIGURE 42. Sub-missile effect.

This effect was used as far back as the Civil war and consists basically of small explosive charges separately fused and placed into a container. The internal bursting charge is designed to hurl the sub-missile outward. They will detonate on impact or in the air by means of a time fuse.

**SHRAPNEL EFFECT**

Where fragmentation relies on the breaking up of the case, shrapnel was designed to ease the burden of the explosive charge.

80

Shrapnel consists of pre-cut or perforated cubes or spheres packed in or around an explosive charge. In many military munitions, shrapnel consists of reject ball bearings, cubes, or arrow-like devices shaped much like darts. The Germans were known to use phonograph needles as a means of producing the shrapnel effect in certain munitions (Figure 43).

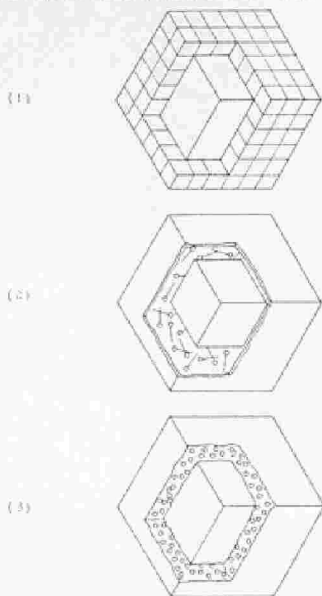

FIGURE 43. Shrapnel effect. 1) Pre-cut cubes with bursting charge. 2) Dart shrapnel. 3) Ball bearing shrapnel.

81

**WHISTLE OR STARTLING EFFECTS**

These effects are obtained by using propellant or a like explosive to create a startling effect by a loud screaming or whistle type of noise. These devices are often made with a whistle followed by a sharp report to give the effect of a bomb or like device falling. They can be hazardous because of the photoflash or black powder bursting charges.

**BLAST EFFECTS ON AUTOMOBILES**

Figures 44, 45, and 46 show two dynamite bombings on automobiles. The effect in either case would be a shattering or a heaving effect indicating a low or a high explosive.

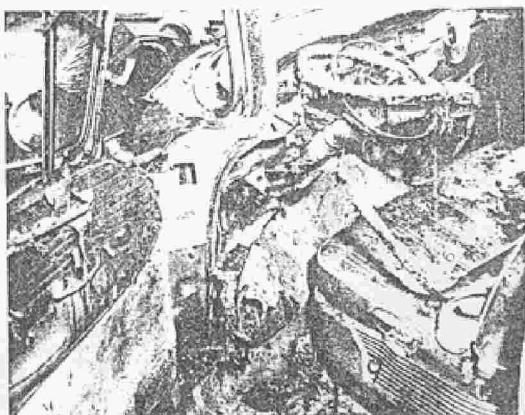

FIGURE 44. Car bombing. Blast effects of dynamite.

82



FIGURE 45. Car bombing. Blast effects of dynamite.

83

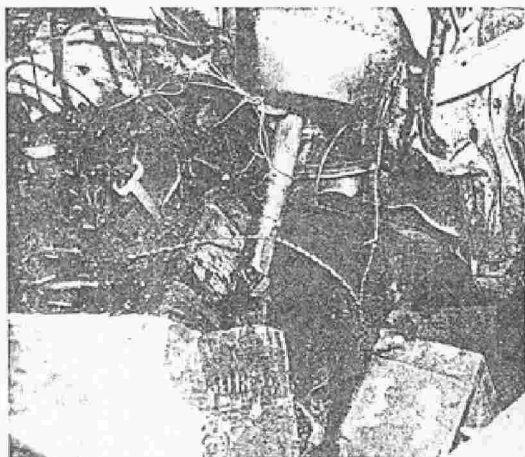

FIGURE 46. Auto bombing showing engine compartment damage. Estimated three sticks of dynamite.

84

*Chapter VI*

**INCENDIARIES (FIRE DEVICES)**

RECORDS dating back to the year 670 mention the use of "Greek fire" as a weapon to strike fear into the enemy, and fire in one form or another has been used in nearly every major engagement since.

Greek fire consisted of mixtures of saltpeter and other combustible mixtures ejected from siphons (tubes) at enemy ships, with a devastating effect in the early days of wooden warships.

The theory and principle behind the use of fire has not changed much since the year 670 as firebugs, psychotics, and many military munitions are used with the same results.

Incendiary materials, when properly employed, are perhaps more effective than explosives because, if not controlled in time,

the target is completely consumed by the fire.

The three essential ingredients or components of an incendiary are a match (initiator), a kindling, and the fuel. Practically any combustible material can be used as a fuel but most saboteurs and professional fire bugs will use a highly inflammable material to insure a proper initiation.

The methods of fuzing for the initial starting can vary from a simple cigarette and match hook to a complex clock work or chemical delay similar to those used for initiating high explosives.

Incendiaries of the manufactured variety should never be underestimated, as a manufactured incendiary may contain an explosive charge to confuse and harass fire fighting operations. Military incendiaries, in many cases, burn at extremely high temperatures: some reaching temperatures as high as 2,200°C.

85

Fire fighting techniques will vary with different incendiaries because water will cause certain incendiaries to explode or react violently, presenting great problems to fire departments.

The above facts certainly indicate a need to study the various materials used and the employment of incendiaries for they can be as lethal and destructive as an explosive.

#### MANUFACTURED AND MILITARY INCENDIARIES

Military incendiaries are used primarily to set fire to buildings, industrial installations, ammunition, fuel dumps, etc. They may be divided into three main categories: oil, metal, and a combination of oil and metal. They are as follows:

1. **Oil incendiaries**—Mixtures of oil and gasoline or thickened fuel mixtures consisting of a manufactured thickener (Napalm) and gasoline. Gasoline is always used as a base for these types. Napalm is often called a mixed aluminum soap. Natural rubber is often used as a thickener material. White phosphorous and metallic sodium are often used as an ignition source for these incendiaries.
2. **Metal incendiaries**—Made from magnesium, and powdered aluminum mixed with iron oxide. These incendiaries require a high temperature for ignition. However, once started, they burn at a fierce temperature and are very difficult to extinguish. Magnesium burns with a blinding white flame and melts as it burns, and the melting mixture ignites everything in its path. Thermite and thermate mixtures of powdered aluminum and iron oxide are used in metal type incendiaries and once started are capable of burning completely through the block of an automobile engine. Thermite mixtures are often used to start magnesium bombs.
3. **Oil and metal incendiaries**—Consist of a mixture of petroleum and various metals such as magnesium, etc. These are often named "PT" mixtures.

86

#### IMPROVISED INCENDIARIES

The inflammable materials which can be used in improvised incendiary devices are far too numerous to list here. However, the most commonly used materials, both liquid and solid, are:

- |                        |  |
|------------------------|--|
| 1. Gasoline.           | 7. Acetone.                            |
| 2. Kerosene.           | 8. Iron oxide.                         |
| 3. Assorted solvents.  | 9. Metals (magnesium, aluminum, etc.). |
| 4. Alcohol.            | 10. Wax.                               |
| 5. Carbon di-sulphide. | 11. Potassium permanganate.            |
| 6. Paint thinners.     |  |

- |   |                        |
|---|------------------------|
| 12. Glycerin.                               | 16. Sawdust.           |
| 13. Cellophane.                             | 17. White phosphorous. |
| 14. Acids (hypergolic mixtures).            | 18. Metallic sodium.   |
| 15. Commercial heat devices (Sterno, etc.). | 19. Black powder.      |

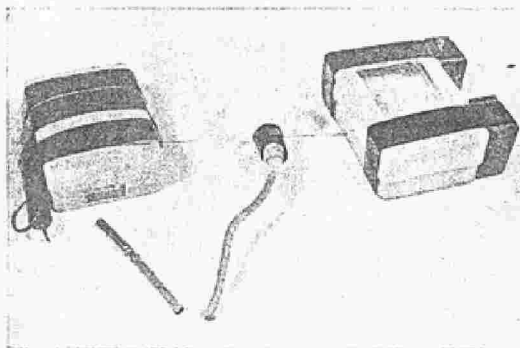

FIGURE 47. Soap-dish incendiaries.

87

These devices are in wide use by terrorists and saboteurs and consist of a plastic soap dish filled with an incendiary mixture ignited by a squib, igniter, or like device. Magnets are often taped to the soap box to facilitate rapid attachment to a metallic object. These devices burn with an intense heat (2,000-3,000°C) and have been known to burn completely through the solid block of an automobile engine. Metal incendiaries are considered most violent.

#### ACTUAL INCENDIARY MIXTURES

1. Mixtures of sulfuric acid and gasoline arranged to react hypergolicly with a dry mixture of potassium chlorate and sugar.
2. Potassium nitrate with sawdust.
3. Paraffin (wax) combined with gasoline.
4. Soap flakes combined with gasoline.
5. Mixtures of plaster of paris, water, and aluminum powder.
6. Mixtures of potassium chlorate, sulphur, ground coal or sugar, iron filings, and wax.
7. Mixtures of potassium chlorate and sugar.
8. White phosphorous mixtures—used submerged with carbon di-sulphide, kerosene, or plain water. Upon exposure, will react.
9. Metallic sodium and calcium carbide—these are often called "firelys" and are arranged in a gelatin capsule and inserted into the gasoline tank of an automobile. After a pre-determined time, the gelatin dissolves and upon contact with moisture, they react violently exploding the gas tank.
10. Mixtures of black powder and aluminum powder.
11. Railway and highway "fuzes."
12. "Sterno" or canned heat variations.
13. Sponge platinum wire in gas tank suspended into a cork to ignite gasoline as the tank empties.

88

## MOLOTOV COCKTAILS (FIRE BOMBS)

A hand-thrown incendiary type of device used perhaps as far back in time as Moses. These bombs have a tremendous psychological and devastating effect. They became very popular through use by the Russians during World War II and were nicknamed "Molotov Cocktails." A very crude and simple version is illustrated in Figure 48. More exotic and complex versions are found in Chapter 8.



FIGURE 48. Molotov cocktail incendiary device. Gasoline filler and saturated

wick  
89

FIGURE 49. Left to Right: Modern Molotov and snow ball incendiary devices.

A modern Molotov consists of a bottle filled with  $2\frac{1}{2}$  gas and  $\frac{1}{4}$  sulfuric acid. A blotter which has been saturated in potassium chlorate and sugar mixture is wrapped and secured to the bottle.

When the bottle is thrown against a hard surface and broken, the blotter acts as an igniter.

A snow ball consists of potassium chlorate and sugar mixture embedded in a wax mold, using a length of safety fuse for an igniter.

This group is rather unique and is designed to be hand-thrown with great effect. It can consist of a simple wick attached to a bottle of gasoline or may utilize various acids and chemicals designed to react violently upon bursting. The early Russian versions consisted simply of a wick inserted into a bottle of gasoline. When a target approached, the wick was lit and the cocktail thrown at the target.

Modern versions incorporate the use of acids mixed with the gasoline and wicks attached to the outer bottle which, when broken upon impact, will cause a violent reaction or immediate flame. Two versions of this which may be encountered are:

1. A mixture of alcohol and gasoline using a chrome oxide strip taped to the bottle which, when thrown, will burst violently.
2. Mixtures of gasoline and sulfuric acid, with igniter materials taped to the outside; such as potassium chlorate and sugar wicks. These combinations will react violently when the bottle is broken.

## PYROTECHNICS

These items are designed to produce a brilliant light for illumination, or various smokes (colored) for signal purposes. We cannot just forget this group because many military illuminating devices are so manufactured as to be propelled to great heights into the air and burn with a very great intensity. The screening smokes have been used on occasions by members of the underworld to screen their actual activity and certain types of smokes can be somewhat toxic in nature. A highway "tuzee," for example, would be considered as a pyrotechnic item as it produces illumination for emergency purposes. It could also be used as an incendiary due to its heat producing qualities.

These items normally consist of a friction or percussion igniter, a delay fuse, priming charge, first fire, and main charge. An improvised pyrotechnic can be handled with normal fire precaution. However, a military pyrotechnic should be handled with care and military assistance should be sought as certain military pyrotechnics are extremely hazardous to handle.

The prime identification feature on most pyrotechnic items are vent or emission holes on the outside of the container. However, this may not hold true in all cases as some are designed to fire by means of an internal bursting charge.

## LACRYMATES (TEAR GAS)

Lacrymates are sold in practically every hardware or sports shop with no restrictions or control as to the purchaser. They

91

run in assorted sizes from the pencil gun to a grenade size, and are sold as a protective item. Their use as a weapon against society is highly probable because they have the power to incapacitate and, if used in great quantities, can be lethal. Most peace officers are quite familiar with the protective measures and effects of tear gas. Today, almost anyone can purchase these items and, if stockpiled in quantity, they could be used as a weapon against society.

There are also recorded cases of lacrymates being used against certain business establishments, to cause the establishment to

submit to certain demands. It is reasonable to assume that any place of business subjected to a tear gas bombing periodically is going to suffer a decrease in the number of people frequenting this establishment (Figure 50).



FIGURE 50. Military tear and choking riot control grenade. This grenade also uses a vomiting agent.

These bombs present hazards to the peace officer. In many cases, they are constructed with delay mechanisms designed to explode the tear gas at a predetermined time, allowing the perpetrator time to escape. The lacrymates alone are a problem if not handled correctly.

Most military lacrymates will bear the symbols CN or CS and in some cases will use a combination symbol of CN:DM. The grenades will be round in shape or resemble a beer can with a standard grenade fuze and emission holes.

92

**STINK BOMBS**

Most people can recall photo film or other chemicals placed in a theatre or public place as a means of creating confusion or near panic. These childish pranks, using the "rotten egg" smell, cause people to disperse and move from the area quite rapidly. This theory is not only used by pranksters but has become a science among persons attempting to have business establishments sway to their ways of thinking or doing. The art of the simple stink bomb with a delay fuzing system has become quite efficient indeed! Figure 51 illustrates a simple device using oil of valerium, sulfuric acid, and zinc strips which, when coupled, will cause a violent reaction capable of clearing even the best of establishments. The odor or after effect of this device is so foul that it requires a complete renovation of the establishment to eradicate the smell. The high gas pressures developed by this instrument could present great hazards to a peace officer should he arrive on the scene at the precise moment it were to explode.

We cannot, therefore, underestimate even the most simple device, because high gas pressures could be involved; creating a mechanical explosion capable of doing great damage with high velocity fragments.

93

**HOAX BOMBS**

These are encountered by peace officers perhaps as much as a live loaded item, and must be treated as live until rendered safe.

The perpetrator in this case uses inert materials (simulated dynamite, etc.) and attempts to scare his victim with the thought of a live device.

These devices are rather unique and vary from flashing light bulbs to a simulated package of explosives with clock delay and the entire package would fire if it were real.

This type of package should be investigated as thoroughly as a live one because, in many cases, the perpetrator will follow up

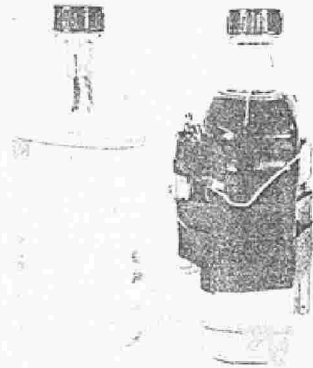

FIGURE 51. Stink bombs. Left: Mechanical explosion. Right: Clock delay with blasting cap fuze charge.

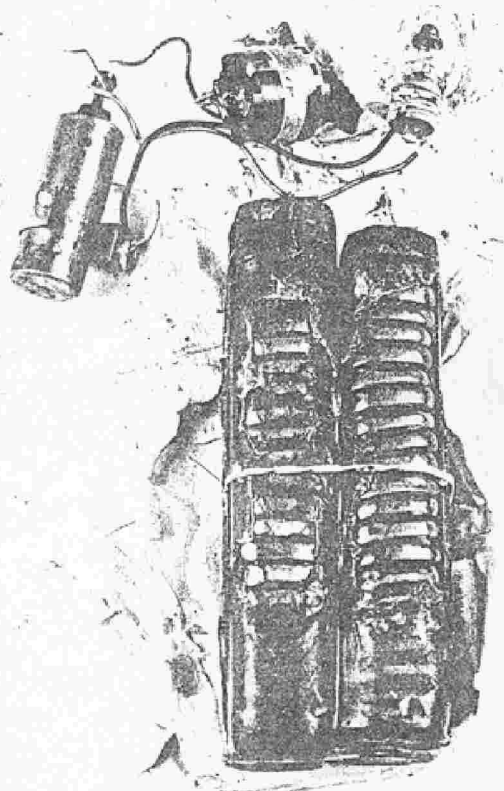

FIGURE 52. Hoax bomb rigged with blinking light and no explosive. Often called "fake" bombs.

with a live device and most certainly has the ability to do so. We can assume that any individual whose hatred is deep enough to create a hoax device as an instrument of fear is most certainly capable eventually of creating the real device.

95

Many bomb disposal personnel are called in to render safe such items as electric tooth brushes and toys. Often the entire area has been evacuated for this job. This may prove embarrassing to the disposal expert, but should chalk it up to good training for the next device may not be a hoax. If it is a "suspected" package, then we are obligated to give it the full attention and precautions of a live item.

There are recorded incidents of several hoax type devices neatly designed to cause the expert to relax his procedure, followed by an ingenious booby trap designed to kill the expert whose guard was dropped through a hoax.

96

## Chapter VII

### APPLIED PHYSICAL PRINCIPLES

THE science of physics must be learned prior to teaching the fuzing and firing systems in military munition. All military munitions utilize physics in the many complex fuzing systems encountered. The triggering of fuse systems in improvised munitions will require at least a basic background in the physical principles set forth in this chapter.

The forces of velocity, set back, acceleration, impact, and inertia play very important roles in the arming and firing systems in the military ordnance field today. It is important to know whether a fuse is fully armed, partially armed, armed and functioning, or dud-fired upon visual observation and during the rendering safe procedure.

Of all the systems encountered, the electrical fuse is perhaps the most dangerous a peace officer may encounter. The power sources today have been miniaturized (pen lights, hearing aids, etc.) to such a degree that a small bomb can be placed inside a package of cigarettes with delays up to twelve hours. A person with a background in electronics can incorporate anti-disturbance and booby trap systems in these miniature lethal packages by wiring up devices in parallel within the package. The author has personal knowledge of two electronic devices that caused the death of one disposal man and severely injured another. The first, a well-known technician reached into a clandestine package with a pair of steel cutters and cut what appeared to be a single strand wire, but, as it turned out the wire was in reality a double strand system. His steel cutters acted as a switch, firing the system and completely severing his arm.

97

Another case involved an expert who reached into a package and very methodically cut all the wires, removed the detonator from the main charge, and breathed a sigh of relief. He then picked up the package and, as he tilted it, the bomb exploded, killing him instantly.

Investigation later disclosed that the terrorist had very neatly placed a small separate bomb in the package near the main charge and wired it electrically with small pen light batteries and mercury switch. The disposal expert took for granted the obvious, main charge was safe and, upon picking up the package, had activated the small concealed bomb which sympathetically detonated the large charge.

This little trick is simple, but may deceive the best experts.

By now you can begin to realize that we cannot stereotype or take for granted the perpetrator of a clandestine device. Every electric circuit encountered will have a power source (battery), a load resistance which utilizes the current, and wires to conduct the current from the source to the load. In addition to the above components, the bomb, when constructed with an electric circuit, will have a switch device and perhaps an arming delay mechanism to put the operator at a safe distance. The simple circuit shown in Figure 53 shows the basic components necessary in an electrical fuzing system.

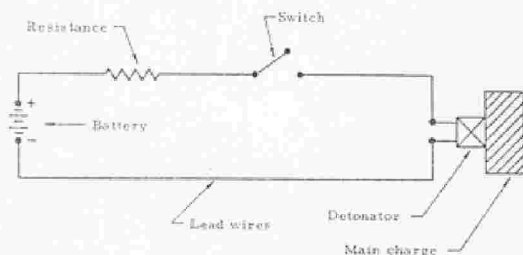

FIGURE 53. Basic electric circuit.

98

The resistance symbol shown is not necessary in this circuit, but the wire itself will afford some resistance to the current. Therefore, I show the electrical symbol. As you can see by the diagram, the switch is in the open position but the instant it is closed, the current load is dumped into the electric detonator, firing the main charge. A variation of this circuit is shown in an actual time bomb (Figure 54). The switch in this case is the clock mechanism.

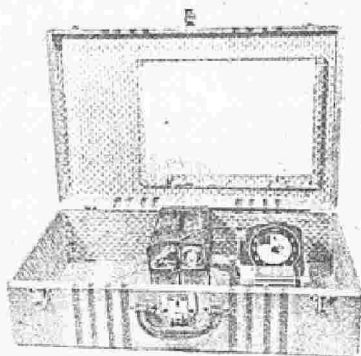

FIGURE 54. Suitcase bomb electric circuit delay device. Twelve hour delay with clock used as a switching device.

The circuits shown in Figure 53 and 54 represent very basic circuits and very basic mechanisms. It is important that every peace officer study basic electronics during his training phase in bomb disposal as certain circuits can be extremely complex. Any electronics technician with an electric blasting cap, improvised igniter, and a main charge can most certainly construct an infernal machine far beyond the concept of an untrained technician. A good example of a complex circuit which was found is shown in Figure 55.

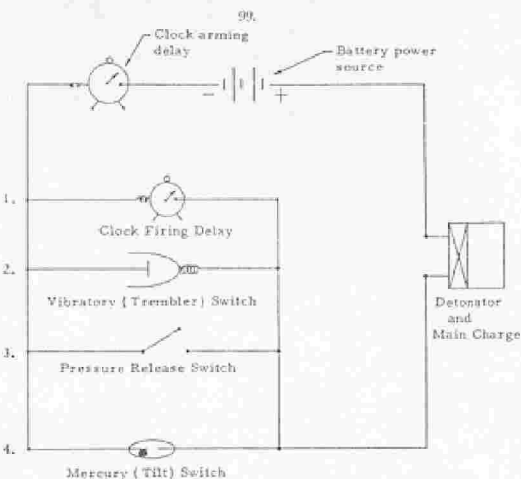

FIGURE 55. Long delay, anti-disturbance, booby trapped circuit.

case acted as a storage reservoir (condensor) and stored up the electrical energy. On contact with the stored electricity (which is always seeking ground) it was discharged, giving a shock. This is known as static accumulation of an electrical charge.

The Germans during World War II constructed a bomb fuze utilizing this principle and called it the "dust fuze." It consisted basically of two cells using unlike metals and filled with talcum powder or dust. In addition, the fuze had a storage capacitor (condensor) to store up the electrical energy generated. The operation was very simple: as the fuze was dropped from the airplane, an arming device opened the air vent in the fuze causing the talcum dust to vigorously blast the two unlike cells, in turn creating an electrical charge which was stored in the capacitor.

Upon impact, a switch was closed, dumping the stored electrical charge into an electric detonator, and firing the bomb. Bearing in mind the example of the seat covers, the peace officer who attacks any electrical circuit should first ground himself by merely reaching down and touching the ground with his finger. Do not wear nylon clothing as this tends to build up a static charge rapidly and could cause an electric detonator to fire.

**Chemical Cells**

Two dissimilar metals in the presence of an electrolyte (acid) will create a current. A good example is a dry cell flashlight battery which contains carbon, zinc, and ammonium chloride (Laclanche cell).

Another version is your car battery or what is known as the wet cell, which contains two unlike metallic plates and sulphuric acid as an electrolyte. Chemical cells containing enough power on a one shot basis to fire an electric cap have been miniaturized almost to the size of a ten-cent piece as in hearing aid devices, wrist watches, etc.

**Thermal Cells**

One of the newer batteries used on a one shot basis consists of two unlike metals, a dry salt electrolyte, and an incendiary mixture. This battery has a tremendous shelf life as the materials are inactive until it is activated. The principle involves the incendiary which, when ignited, will melt the salts and immediately give a current flow that will only last for a few minutes. It is highly unlikely that a psychotic or saboteur would resort to the use of thermal batteries as a power source when dry cells or wet cells would accomplish their mission much better.

**Heat Source**

Often called the see back effect, consisting of two different metals twisted together to form a junction. The two different metals develop opposing voltages and the energy is available for use.

**Light Source**

These consist of two types:  
 a. Excited type.  
 b. Self-excited type.  
 They are often referred to as the photo-electric cells and could be used as a booby trap if properly employed. The photo cell consists primarily of a metal plate and selenium alloy. When light strikes this device it causes a current flow. A good example of the self-excited device is an automatic door which opens as you break the beam.

Many hobby shops today sell the photo-electric type cells for

This circuit most certainly shows that problems can arise in electric circuits. The circuit shown in Figure 55 represents what is known as a straight parallel circuit and one can readily see that any attempt to disturb the package, once the arming delay is completed, will result in an immediate detonation or explosion. The diagrams shown represent large scale drawings but one should bear in mind that the entire circuit shown could be contained in a box the size of a cigarette package, using pen light miniature batteries.

To summarize, all that is needed in any electric circuit is: the power source, the wire, the switch, an initiator, and the main charge.

**POWER SOURCES**

This section will deal primarily with the more common sources of electrical power in order to acquaint law officers with the many versions of power which could be utilized in any electric circuit. These power sources are:

1. Friction power source (static charge).
2. Chemical cells.
3. Thermal cells.
4. Heat source.
5. Light source.
6. Pressure (on crystals).
7. Magnets.

**Friction Power Source (Static Charge)**

It is very unlikely that the friction type of power source will be found in any electrical bomb, but the principle should be explained as the hazards involved with a static charge could result in the disposal officer accidentally firing the electric cap in any bomb utilizing an electric circuit.

Everyone has departed from an automobile by sliding across plastic or nylon seat covers, as you placed your hand on the door handle it gave off a spark, with quite a jolt. Electrons in this case were collected by the body as two unlike materials (the seat cover and your clothing) were rubbed together. The body in this



as little as \$1.50. These should not be overlooked as a possibility when opening a suspected package.

#### Pressure Sources of Power

This effect is often termed as the piezo-electric effect and consists of certain crystals that, stressed or crushed, will create a current flow. Some crystals used are barium titanate, quartz, tourmaline, etc. Many military munitions utilize this type of system and, once the fuzes are armed, they become extremely dangerous for any further stress may fire the munition. At this time, it should be stated that any military ordnance item should not be touched until a military bomb disposal technician has identified the round.

#### Magnets as a Source of Power

Physics states that an electric current is produced by passing a coil of wire through a magnetic field. This physical principle can also be reversed by passing a magnet over a coil of wire. The current flow will be slight, but enough to activate a sensitive switching device. There are magnetic switching mechanisms termed "search coils" constructed of thousands of turns of wrapped wire that can cause a switch to close by passing a small metallic tool over the coil. It is somewhat remote that a psychonic technician could devise such an item. This would indicate that magnetic precautions should be taken until a device has been identified.

#### 103 SWITCHES

The switches listed below are some encountered in any electric circuit.

1. Knife switch.
2. Toggle switch.
3. Anti-disturbance switches
  - a. Mercury switch.
  - b. Vibratory switch.
  - c. Ball switch: Consists of a small ball bearing resting in an insulated material. When the device is tilted, the ball will roll across a set of contacts completing the circuit.
  - d. Reed switch (vibratory): consists of very sensitive leaf type springs which vibrate at the slightest touch and can be tuned to accept the very slightest movement. For this reason, we should always jar and rattle a package remotely before any physical contact is made.
4. Clock switch: utilizes the plastic face, expanding main spring, or the alarm winding step to complete the circuit.
5. Micro switch: consists of spring-loaded plungers that will close and open various circuits within an electric device when depressed or released. They are very often found in packages designed to fire when the package is opened or jacked up.
6. Electro-mechanical switches: require electrical energy to open or close a switch and are:
  - a. Solenoids (most dangerous).
  - b. Motor switch.
  - c. Grasshopper switch (counting mechanism).
  - d. Explosive switch.
  - e. Dimple switch.
  - f. Caterpillar switch.
  - g. Thermal switch.

Of the electrical switches listed above, the solenoid type should be discussed because of one particular application in ordnance. In this particular circuit, the dry cell batteries activate a solenoid switch, holding the circuit open, and act as a long delay circuit. As the batteries lose their power, the solenoid will close, firing

104

the bomb. Any attempt to remove the batteries or to cut any one wire in the circuit would also fire the circuit. It is most certainly wise to be positive what types of switches are used in a circuit, prior to cutting a wire or removing a power source. This circuit is also referred to as a collapsing circuit.

- b. Electrical switches: certain tube type switches will operate strictly on electronic principles and can be used to collapse a circuit or fire the circuit on a delay basis.

These tubes are:

- 1) Glow tube.
- 2) Gap tube.
- 3) Triode or firing thyatron.

#### Chemical Action(s)

1. **Delay Mechanisms**—Many delay mechanisms, particularly improvised delays, will utilize acids to achieve the delay. Acids, being very corrosive in nature, can be effectively used by merely eating their way through various substances. In addition, certain acids are hypergolic in nature. They cause certain chemicals to burst into flame upon contact and can be utilized to start incendiary fires or initiate certain explosive devices. The following chemical mixtures and their actions are the most common from the standpoint of bomb disposal.

- a. **Sulphuric acid:** The most widely used chemical acid and can be procured from any automobile battery for use. This acid is very corrosive in nature and also hypergolic in contact with certain oxidizers and fuels. Used as a delay device and a firing initiator by eating its way through various materials (cork, rubber, paper, etc.) and reacting violently with an oxidizer and fuel, giving a violent flame.
- b. **Cupric chloride:** A very corrosive chemical often used in various delay fuzes to eat through a wire which is holding a spring-loaded firing pin to fire a stab-sensitive primer mixture.
- c. **Nitric acid:** The same as cupric chloride. In addition, is used as a delay and igniter for incendiary mixtures.

- d. **Acetone:** Used in long delay fuzing systems to soften a plastic or celluloid disc which retains a cocked firing pin. The strength of the acetone and thickness of the disc would determine the length of delay. Temperature will affect this type of delay by changing the firing time as much as 200 per cent.
- e. **Electrolytic action:** A delay mechanism which utilizes a copper wire suspended in a solution of copper sulphate and retains a cocked firing pin. When battery (electricity) power is applied, it will eat the wire releasing the cocked firing pin. The amount of power or current will determine the delay.

2. **Material Fatigue**—Material fatigue is often referred to as the "lead break" method and is used in certain items of ordnance to achieve a delay in either arming or firing. It consists very basically of a lead wire which, when stressed with a spring, will stretch the lead wire and eventually "break" it, releasing a spring-loaded firing pin.

3. **Mechanical Action**—This alone would cover an entire volume if all variation were discussed. For purposes of this chapter, fuzes will be representative of the various mechanical methods utilized to release cocked firing pins. The two types of firing pins of prime importance are:

- a. The cocked firing pin (most dangerous)

## b. The uncocked firing pin.

106

Figure 56 best illustrates the cocked firing pin and in this case is being retained by what is known as a retaining pin. This is the most simple of the group. The only physical requirement for this version is to withdraw the retaining pin. Many complex ordnance items, however, will use ball bearings, sliding sleeves, and pins to release the cocked striker.

Another device used to release a cocked firing pin is known as a silhouette device (Figure 57).

Operation: A spring-loaded firing pin retained in the cocked position by the small opening of the silhouette plate. As pressure is applied to the plate, the large opening will move down, releasing the firing pin. The pin is then driven forward into the small arms cartridge primer which in this case would be used as an igniter for black or smokeless powder.

107

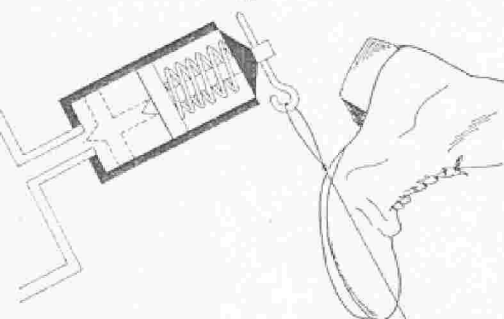

FIGURE 56. Cocked firing pin (pull initiated) device.

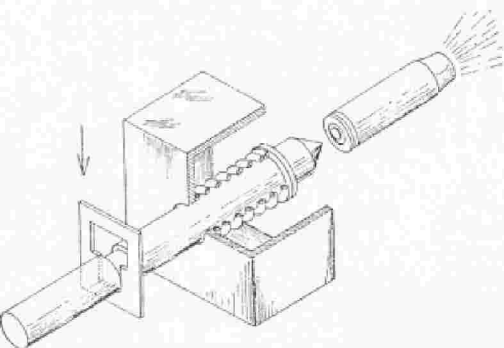

FIGURE 57. Silhouette cocked striker release device.

108

Another mechanical device quite common to clockwork delay mechanisms is termed the timing disc (Figure 58). This is primarily used in military demolition clock systems.

All military or manufactured clockwork mechanisms should be treated with the utmost in safety precautions as the spring-wound timing disc may have stopped within seconds of firing time and any subsequent movement could restart the clock, causing a detonation. The Germans during World War II manu-

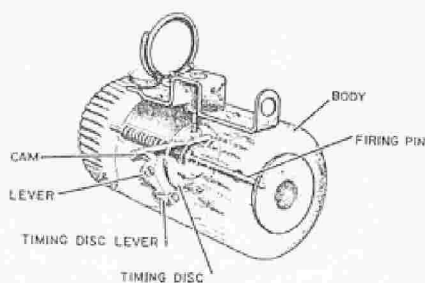

FIGURE 58. Clockwork timing disc.

factured clocks using timing discs of a silent nature. Therefore, the device could be functioning at the time of gaining access to the package or device.

The device shown in Figure-58 could present a great hazard to any person who might disturb it, should it fail to function. Any disturbance might cause the disc to rotate and release the firing pin. Leave all military munitions to the military experts.

4. **Uncocked firing pins**—This is cocked and fired all in one operation and can be done by application of pressure, tilting, or pull. A good example is the fiber spring called the "Belleville spring" (Figure 59). This device, from a bottom view, resembles a saucer and is constructed of a fiber or plastic material which will give it a snapping action similar to the metallic springs utilized in "crickets" that children snap to make a noise.

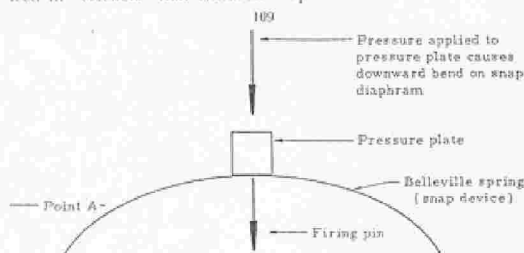

FIGURE 59. Belleville spring (snap diaphragm).

As the Belleville spring is depressed beyond point "A", the fiber or plastic will snap downward with enough force to initiate a detonation.

#### Initiating Actions

The initiating action must be identified before attempting a rendering safe procedure. The initiating action is considered to be the first step or combination of steps which causes the device to function. This could be a simple step, such as pulling a wire or cord, or a complex device using a combination of many initiating actions such as pressure, pull, pressure release, etc. The four main systems which could be used to fire a detonator are:

1. Mechanical actions.
2. Chemical actions.
3. Friction.
4. Electrical current.

The first action which starts function of the fuzing system is termed the initiating action. Initiating actions are classified as:

1. Pressure.
2. Pull.
3. Pressure release.
4. Combinations.
5. Thermal.
6. Tilt.

- 7. Anti-photo.
- 8. Barometric.
- 9. Delay.
- 10. Proximity.
- 11. Controlled.
- 12. Anti-withdrawal (A'W).
- 13. Booby trapped (B'T).
- 14. Collapsing circuit.

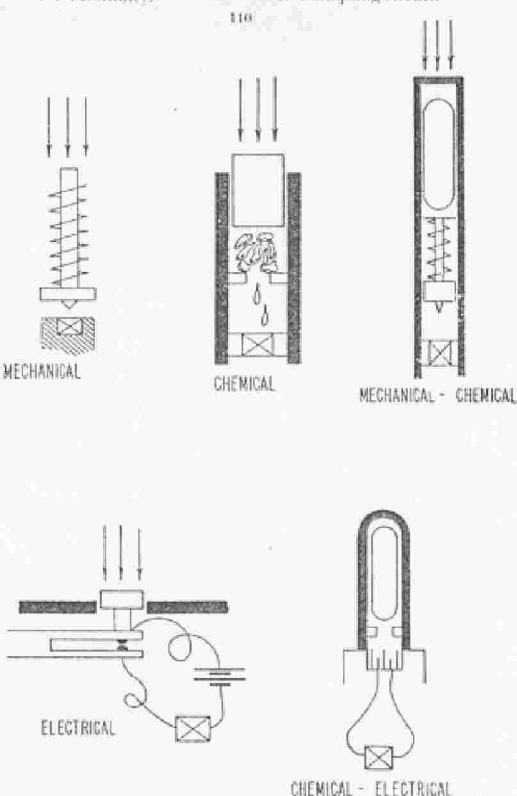

FIGURE 60. Fuzing systems.  
111

Further details of the initiating actions listed will be covered under each separate fuze in the fuzing and triggering section, Chapter 8. It can readily be seen that with the many combinations of initiating actions, the job of bomb disposal may become frustrating.

**Sympathetic Detonation**

If one explosive detonates near another explosive, it may cause other charges to detonate in the immediate area. The detonating wave or shock wave from one charge will cause the other to detonate within critical distances. It is difficult to say just how much of a charge will detonate another at what distance because many factors are involved, such as the sensitivity of the explosive, the mass, etc. In most cases a one-half pound block of TNT placed twenty-six inches on a flat plane from another block will cause detonation of the second explosive block. Sympathetic detonation is important as, in any clandestine package, there is the possibility of one or more separate charges capable of firing on their own power and each may sympathetically detonate the

other charges.

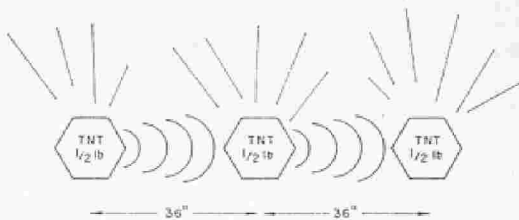

FIGURE 61. Sympathetic detonation table. One-half pound blocks of TNT spaced thirty-six inches apart.  
112

**Chapter VIII**

**TRIGGERING METHODS, FUZING SYSTEMS, AND FIRING DEVICES**

AS indicated in the applied physical principles section, the most important step, once access is gained to any device, is to be able to recognize the initiating (triggering) action or combination of actions which will fire the mechanism. These systems may range from a simple pull release mechanism to a complex electronic circuit, such as photo-electric, utilizing many anti-withdrawal or protective devices. For purposes of grouping, we consider the fuzing systems as initiating actions which can be constructed to explode or ignite; using mechanical, chemical, friction, or electrical devices.

The initiating action is considered to be the first step or action which will cause the normal firing train to ignite or explode the device. The initiating action or combination of actions are:

1. **Pressure**—Directly applied pressure on a plunger or any flexible device which will close an electric switch, release firing pins, break chemical vials, and fire the device as a result of this application.
2. **Pull**—Consists of wires or cords which, when pulled, will close electric circuits or release firing pins to fire the device. This action is considered quite sensitive and is used on doors or inside packages as an anti-lift device.
3. **Pressure release**—A device which will fire on a release of pressure or a restraining weight. Normally these devices utilize a spring-loaded firing pin or an electrical micro-switch which will fire the device as the pressure is removed. They are easily concealed and are considered most dangerous as they can be assembled inside a package or placed inside a book or under an object to fire as the object is opened or picked up. These types of initiators are an example of why we must attack a suspected device by remote means.
4. **Combination devices**—A combination of initiating actions assembled on one fuze, such as a combination pressure and pull fuze, which will fire either on applied pressure or pull.
5. **Tilt**—Consists of a lever or rod connected to the device in such a manner that, when direct pressure is applied, the fuze will fire. Another application of the tilt action is the use of sliding contacts, ball bearings, or a mercury switch which will fire the fuze as the device is tilted or moved. These are most dangerous and no suspected package should be moved by hand until the mechanism is identified.
6. **Thermal**—Bi-metal strips obtained from toasters, steam

rons, or like devices which will fire as heat or cold is applied. They have a thermostatic action and, in certain cases, will indicate a delay period until the proper temperature is reached. A fine example is the engine of an automobile: cold prior to starting but that will heat on running, causing the bi-metal switch to close.

7. **Anti-photo** — Consists of a device which will fire as radiation is applied. A rather complex system but could be employed to defeat X-ray machines in photo operations.

8. **Barometric** — Consists of a bellows or balloon system which will expand or contract on altitude or pressure changes, firing the fuze. These have been used in sabotage devices and were placed in aircraft so that, as the aircraft reached the proper altitude, they would close a circuit and fire the device.

9. **Delay** — Any mechanism which will fire the device in a given time and may run from minutes to days. There are numerous methods to achieve these delays, and are very dangerous to render safe due to the element of unknown time. Some of the more common delay devices are as follows:

a. **Clock work delays:** pulley devices or those constructed

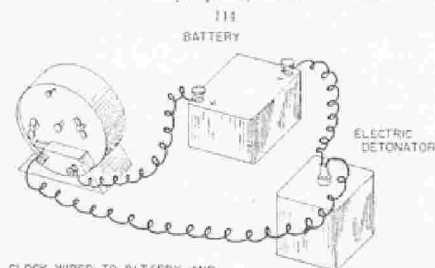

FIGURE 62. Clock work delay unit assembled.

with electrical switches are designed to fire the fuze or igniter at a pre-determined time. Most crudely improvised timers will have about a two to four hour maximum delay. However, certain military demolition or sabotage clocks may run as high as 120 days in delay time. Figure 62 illustrates a basic clock delay mechanism.

115



FIGURE 63. Wrist or pocket watch with electric delay device.

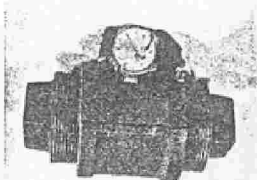

FIGURE 64. Wrist watch delay employed in pipe bomb.

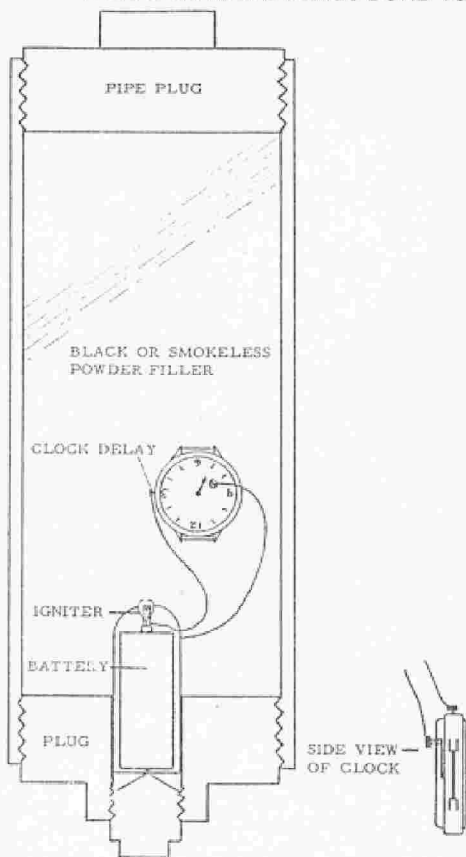
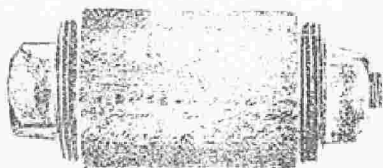

FIGURE 65. Small clock delay unit installed in pipe bomb with improvised igniter unit.

117

New York Journal-American • Sat. Sep. 11 1939

## Mad Bomber Mystery



b. **Chemical delay:** consists of acids (sulphuric, etc.) which will eat through a given material after a time. In some cases, a chemical, such as acetone, which will soften a plastic device, releasing a trigger or firing pin after a pre-determined period. Some chemicals used are cupric chloride, sulphuric acids, nitric acids, etc. Heat and cold effect these types of delays as on

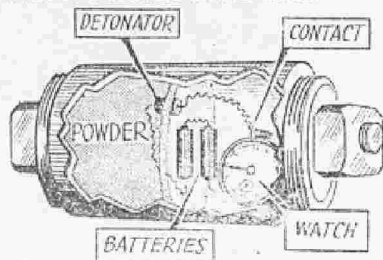

FIGURE 66. Exact replica of the clock delay time bomb used by the "Mad Bomber of New York." (Courtesy New York American Journal)

118

hot day the chemical action is faster and cold weather slows down the action.

c. **Water drip or expanding delay:** used by the Germans during World War II and consists of water expanding dried peas, or water slowly dripping from a tin can to raise a buoyant object (corks, etc.) to eventually fire the circuit. The British applied the method in a rain barrel to which copper sulphate had been added. As the rain or gutter spout filled the rain barrel; the water, now conductive, would close around two open wires located near the top of the barrel and would complete an electric circuit, firing the bomb. This principle was also applied in toilet reservoir bowls on occasions.

d. **Material fatigue:** often termed as the "lead break" delay and consists of a lead wire or similar material which, when spring tension is applied, will eventually stretch out and break after a pre-determined time.

e. **Electric delay:** consists of the use of batteries, resistors, and gap tubes which will fire at a pre-determined time. These devices are difficult to detect once employed because they cannot be heard with electronic stethoscopes.

f. **Electrolytic delay:** consists of a dry cell battery, variable resistors, and a copper wire (spring-loaded) in a solution of copper sulphate. As the battery power is applied, the copper sulphate will eventually eat the copper wire, releasing a spring-loaded pin. Delays on this device are known to range as high as 120 days.

g. **Time fuze delay:** consists of a simple burning fuze to ignite or explode the device. Some commercial fuzes can range into hours of burning time.

h. **Cigarette and match book delay:** consists of a burning cigarette placed in a match book which will ignite as the cigarette burns into the matches.

119

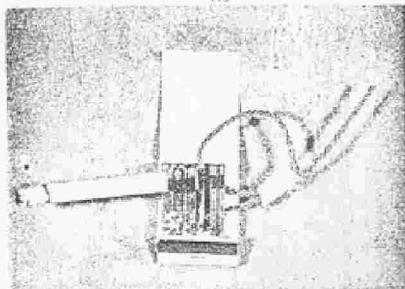

FIGURE 67. Cigarette and matchbook delay device.

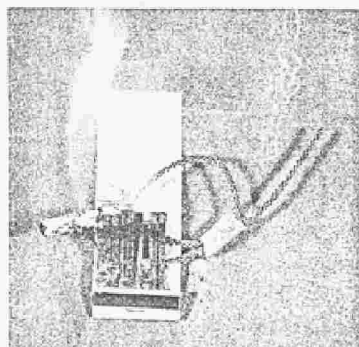

FIGURE 68. Cigarette and matchbook delay device at the instant of ignition.

120

i. **Magnifying glass delay:** consists of a magnifying glass focusing the sun rays on a flammable material and has been employed by saboteurs in incendiary devices.

10. **Proximity Initiators**—Perhaps the most dangerous of the entire group of initiating actions and in some cases impossible to render safe, once they are armed. They consist of very sensitive devices, such as vibratory or trembler switches, which will fire the device at the slightest touch. Examples are:

a. **Vibratory switches:** leaf springs and hair springs or like devices designed to fire at the slightest vibration. They will normally utilize an arming delay to allow the perpetrator time to get away from the device.

b. **Magnetic induction or magnetic movement:** designed by use of magnets to fire as any metallic object (tool) is passed near the device.

c. **Photo-electric:** the use of selenium cells to fire on the receipt of light or darkness.

d. **Acoustic:** designed to fire on the receipt of certain sounds and is constructed by use of a microphone.

e. **Frequency induction:** designed to defeat the use of a mine detector as this system will fire on certain cycles of frequency.

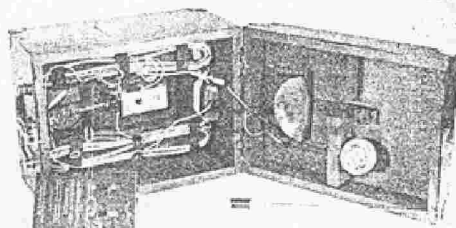

FIGURE 69. Radio-controlled transmitter and receiver unit.

121

11. **Controlled actions**—The use of electric wires or controlled mechanical devices where the perpetrator has control of the time of firing. Another example of this action would be radio controlled by use of a transmitter and receiver type of device.

12. **Anti-withdrawal and Booby Trapped Actions**—These are often termed as protective types of actions and may be employed in conjunction with a delay action to fire the device if it is dis-

turbed prior to the delay firing time. It could consist of one or any number of the initiating actions already listed.

13. **Hydrostatic** — A system which will fire a device on the application of water pressure. Used primarily in military munitions for anti-submarine munitions.

14. **Collapsing Circuit** — Consists of an electric circuit using energized relays designed to fire the item if any one wire is cut or severed. NOTE: It is extremely important that all electric circuits are most positively identified before removal of any electrical component is attempted. If any doubt exists, the wires and/or batteries should be severed or removed by remote means to preclude the danger of a collapsing circuit.

15. **Anti-probe Circuit** — This circuit is rather unique in that the inner box or package is assembled using two layers of aluminum or other metallic foil separated by an insulating material. The circuit is connected electrically to each foil wrapper and if a metallic probe or knife is inserted, the circuit will close, firing the bomb. This device has actually been used and should remind all peace officers not to attack a package with metallic tools by hand methods.

16. **Anti-submerge Circuit** — Consists of a salt tablet or copper sulphate in a gelatin capsule rigged in a plastic tube near two open leads of the firing wire. If the package is submerged in water or other similar fluids, the salt or sulphate will cause the circuit to conduct and fire.

#### MILITARY FUZES, FIRING DEVICES, AND SYSTEMS

The following figures will best show the various types of fuzes used by military units in placed munitions; should the peace officer be confronted with such items. Regardless of country, these

122

devices will bear the same characteristics. In many cases, the rendering safe procedures will consist of merely replacing a safety pin but one should bear in mind that most military fuzes utilize cocked firing pin springs and are, therefore, highly sensitive and dangerous until neutralized. In addition, certain military fuzes may contain anti-withdrawal and booby trap devices, especially if long delay is employed. If there is any doubt on military fuze systems, a military expert should be consulted.

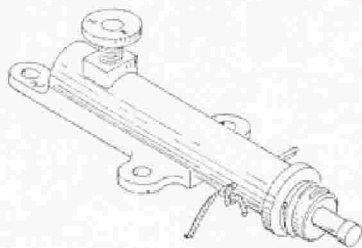

FIGURE 70. M-1 pressure device.

A standard U. S. firing device used in anti-personnel or improvised mines. It consists of a barrel, head, and base assembly. A spring-loaded firing pin is located in the barrel assembly and retained by the plunger on the base. A pressure of twenty pounds applied to the plunger releases the firing pin which fires the primer, detonator, and main charge. A three-pronged device can be attached to the plunger assembly for use in grass or weeds, making the device almost impossible to see with the naked eye.

123

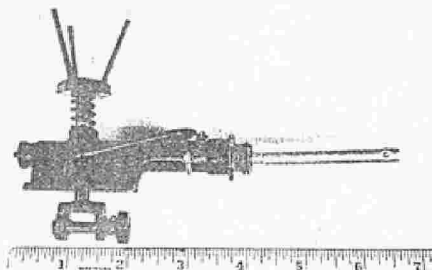

FIGURE 71. Combination firing device.

This device is very versatile and can be set in a combination of different initiating actions; those being pressure, pressure release, pull, and tension release.

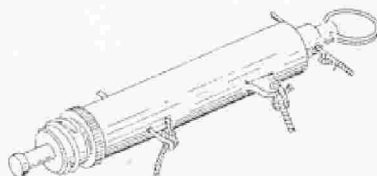

FIGURE 72. M-1 pull device.

A standard U. S. pull-initiated firing device used in anti-personnel and improvised mines. The device, when assembled for use, consists of a fine trip wire attached loosely to the pull ring at the base. A pull of about 3-5 pounds exerted on the wire will release a spring-loaded firing pin, firing the primer. The trip wire used with this device is almost invisible to the naked eye. Rendering safe procedures for most standard firing devices consist of replacing safety pins and carefully checking the trip wires to the anchored end before cutting.

124

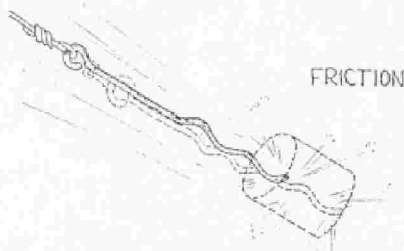

FIGURE 73. Pull friction firing device consisting of an abrasive-coated wire which is pulled through a phosphorus compound, igniting the fuse or exploding a heat sensitive explosive.

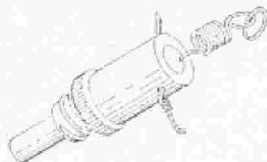

FIGURE 74. M-2 pull friction device.

A small black plastic pull initiated firing device employed by the U. S. in anti-personnel and improvised mines. It consists of an abrasive coated wire which is pulled through a match compound, firing a heat sensitive primer. A pull wire is attached to the pull ring and anchored. A pull of 3-5 pounds will initiate the friction compound, firing the primer and blasting cap. This fuze is almost obsolete today as it absorbs moisture and misfires on occasion.

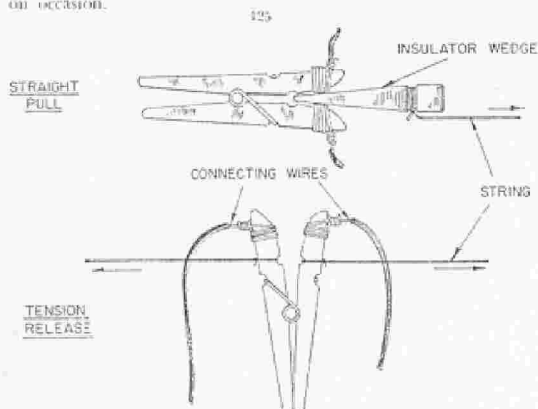

FIGURE 75. Clothes pin electric switching devices.

This device, although simple in construction, is one of the most versatile switching devices in use for mines and booby traps. It consists of an electric circuit which is triggered by the clothes pin switch. The jaws of the pin are held open in the pull version by an insulated wedge, or by a tight wire in the tension release application. Upon initiation, the jaws of the pin will snap closed, completing the circuit. This device can also be employed as pressure and pressure release by variation in the pin assembly. This switch is universally employed by saboteurs and terrorists because of its simplicity.

126

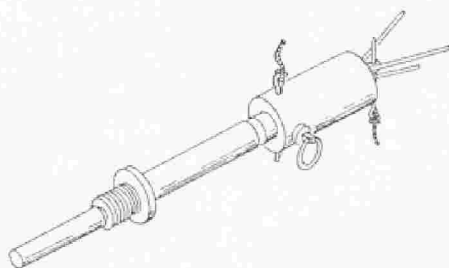

FIGURE 76. U. S. combination pressure and pull fuze.

A U. S. combination firing device that can be triggered by application of pressure or pull. The device consists of a pull ring for a slack trip wire and a pressure plunger on the upper fuze body. A pressure of 8-20 pounds or a pull of 3-8 pounds on the wire will cause a spring-loaded firing pin to fire the mine. This fuze is often employed in the "bounding" variety of anti-personnel mines.

127

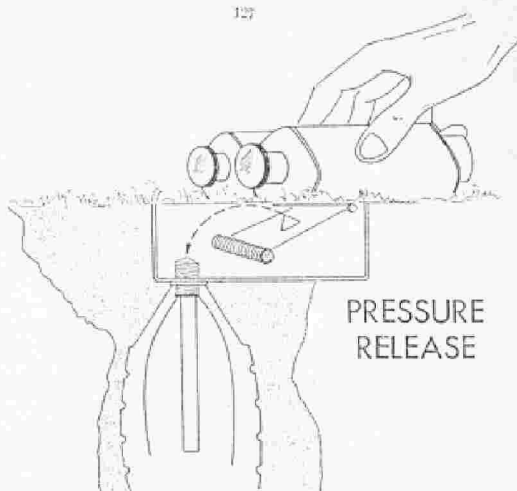

FIGURE 77. Application of a pressure release mechanism. Restraining load, when lifted, will release socketed firing pin.

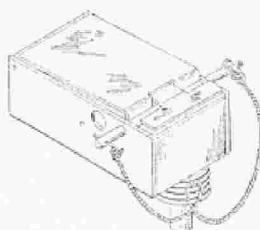

FIGURE 78. M-5 pressure release device.

128

A standard U. S. pressure release firing device, often used in booby trapping operations. It consists of a small rectangular box with a hinged lid. A cocked firing pin is held in position by the lid and, when fully armed, the device is placed under an object or mine having a weight of about five pounds. If any attempt is made to raise the restraining load, it will release the spring-loaded firing pin, detonating the mine. This device is very deceptive and is considered very sensitive, as the load only requires about five thirty-seconds of an inch of lift to cause the device to fire. A rendering safe procedure on this type of device should only be attempted by personnel who have had training with military fuzeing systems.

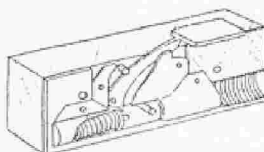

FIGURE 79. German nipolit pressure release device.

A rather unusual firing device used by the Germans during World War II. The entire unit was constructed of a consumable explosive and weighed only two ounces. This unit fired on a



release of pressure, much like the U. S. pressure release firing device. The Germans would place these tiny devices under the standard anti-tank mines to cause the mine to detonate if lifted from the ground.

All-Explosive Pressure Release Device.

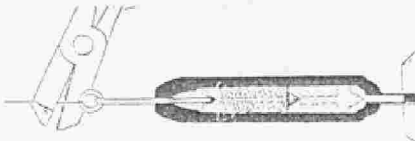

FIGURE 80. Initiation of a tension release fuze.



FIGURE 81. Russian fuze set for tension release in firing action.

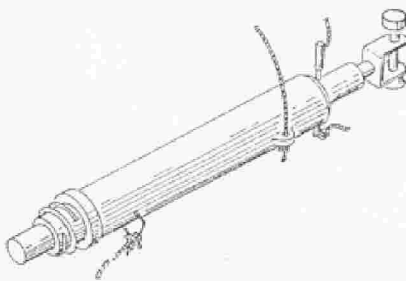

FIGURE 82. U. S. combination pull and tension release fuze.

This device is perhaps one of the most sensitive and versatile of the U. S. mechanical mine fuze group. It is used in any type of booby trapping operation and in nearly all U. S. mines. The device, when fully armed, will fire if the tight wire is pulled or cut. A fine trip wire is attached to the winch at the top of the fuze body and anchored to a solid anchor point. The winch is then used to provide the proper tension for arming. The fuze contains a spring-loaded firing pin which is extremely sensitive when fully armed. Only qualified personnel should attempt a rendering safe procedure on this fuze.

130

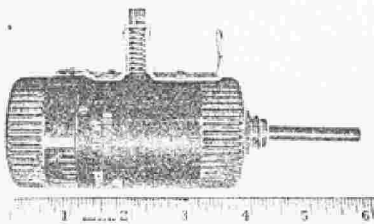

FIGURE 83. U. S. demolition timer (clockwork delay).

This device consists of a clockwork spring-wound timer which is used in demolition operations where long delay is required. This particular timer will give delays up to twelve hours. The timer utilizes a spring-loaded firing pin and timing disc internally.

This device, if found unfired, could be very dangerous as the timing disc may hang up only seconds away from firing time and any subsequent jarring could re-start the clock.

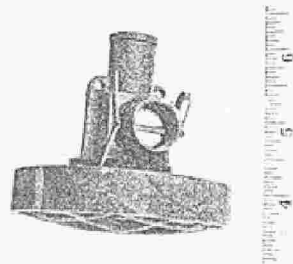

FIGURE 84. Concussion firing device.

The concussion firing device was designed for sympathetic detonation of charges, either in the air or in water up to twelve feet in depth. The concussion of a nearby charge causes a snap diaphragm in the device to drive a firing pin into a small percussion cap. The snap diaphragm is located under the waffle-shaped protective grill on the forward section of the fuze body.

MISCELLANEOUS EXPLOSIVE AND INCENDIARY DEVICES ILLUSTRATED

The following illustrations will show a good cross section of clandestine explosive and incendiary devices that have been used or are depicted in various manuals for employment. As one can readily see by the illustrations, the devices are extremely variable and are limited only to the imagination of the perpetrator.



FIGURE 85. Auto bomb (dynamite, electric cap and clips).

132

The auto bomb consists of about three sticks of dynamite, two lengths of electric wire, an electric blasting cap, and (usually) alligator clips for rapid attachment. This device is universally employed by major crime syndicates and by various terrorist groups.

This device is employed directly on the engine block. However, most professionals will attach the dynamite to the fire wall on the driver's side of the car. One electrical clip is secured to the input side of the coil and the other is connected to a common ground. Amateurs or inexperienced psychotics will normally hook up to the spark plugs and to ground, often resulting in misfires

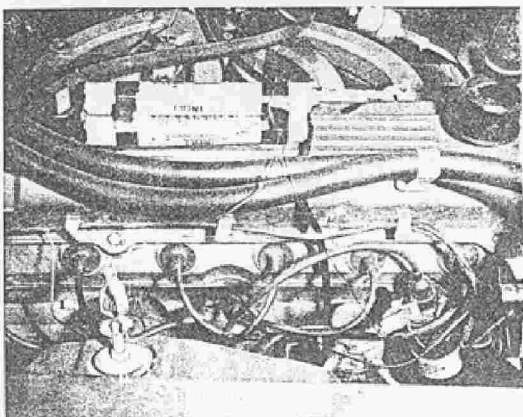

FIGURE 86. Auto (dynamite) bomb installed.

or dual-fires due to insufficient voltage for electric detonators.

133

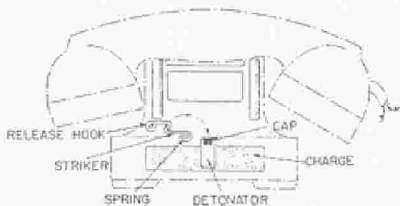

FIGURE 87. Telephone booby trap.

This device is a manufactured booby trap. However, the same type can be improvised. It consists of a spring-loaded firing pin held in position by the receiver. This device has been manufactured for use by terrorists. Another version of this device is with use of a mercury tilt switch and, in certain cases, an electrical pressure release micro-switch.

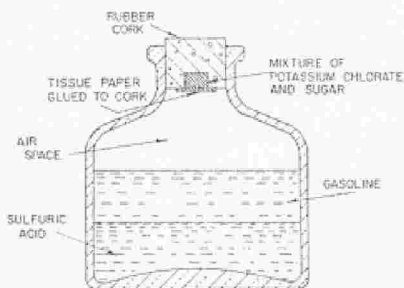

FIGURE 88. Japanese bottle booby trap.

134

The Japanese bottle booby trap is a very violent type of device, difficult to detect as it can be used in any type of bottle or container. The mixture of acid and gasoline, when tilted, reacts violently with the chlorate and sugar, causing a chemical explosion with incendiary effects. The bottle type of booby trap is illustrated in several terrorist manuals today.

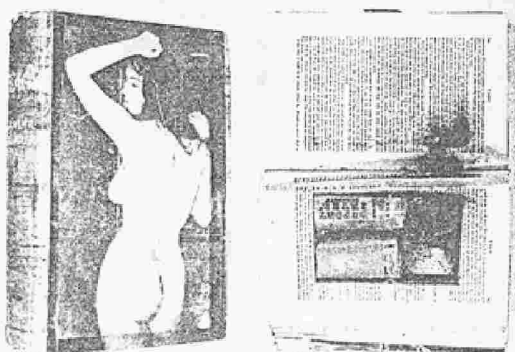

FIGURE 89. Booby trapped book.

This device was often used during World War II by demolition experts and consisted of a pressure release device which was placed inside of a book, filled with an explosive. The book cover was usually covered with an eye-appealing binder to trap the unsuspecting G. I.

135



FIGURE 90. Homemade explosive bombs.

*Left:* Wine bottle bomb, often employed during the roaring twenties. It consisted of a bottle filled with an explosive mixture and initiated by means of a short time fuse. The bottle was wrapped in tape to prevent breakage on throwing. *Right:* Pipe bomb, fitted with a length of burning fuse for initiation. A very lethal device often used by psychotics, terrorists, and saboteurs.

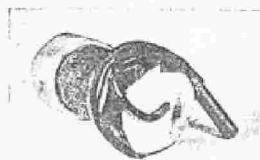

FIGURE 91. Algerian pipe bomb (booby trap).

136

This device appears to be very simple, but is designed to throw

the expert off guard. It consists of a pipe bomb with a length of burned-out time fuze protruding from one end. To most demolition experts, this would appear to be a dud fired item and most people would have the tendency to merely reach down and pick the item up. In reality, the device contains a mercury or sliding contact switch which will fire the bomb as it is tilted. This bears out the fact that even the most simple bomb should be treated with great care until the fuizing system is completely identified.

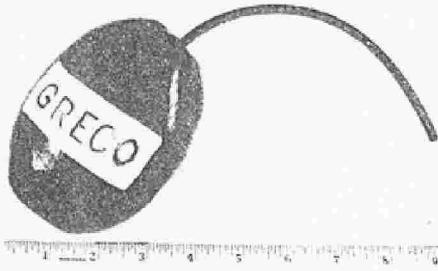

FIGURE 92. Plaster of Paris bomb.

This device consists of an explosive filler surrounded by a plaster of Paris mold for blast effects. A time fuze has been inserted into the bomb for initiation. The perpetrator in this particular case carved the intended victim's name into the side of the bomb prior to employing the device. A recovered bomb of this type would be very valuable for evidence due to the style of printing used by the bomber. In addition, the mold used for the plaster of Paris would probably be retained by the bomber for future bombs.

137

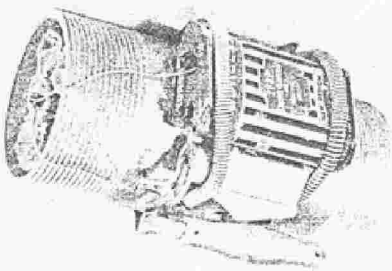

FIGURE 93. Self-destruction suicide bomb.

This type of bomb is primarily employed by the psychotic bent on self-destruction, and who seeks to gain attention. It consists of a bomb fuized with an electrical switch that can be triggered by pressure as the perpetrator desires. It is usually carried into a public area and, in many cases, bank robbers have used this type as a weapon of terror. This type of bomb presents a great problem in the hands of the bomber, as he can trigger the bomb at any time. Careful evacuation of bystanders is very important.

138



FIGURE 94. Telephone booth bomb.

This bomb consisted of a short length of copper tubing filled with smokeless powder and fitted with a length of time fuze. The ends of the tube were crimped to sustain the explosion and the device was employed in pay telephones to blast open the coin boxes.

139

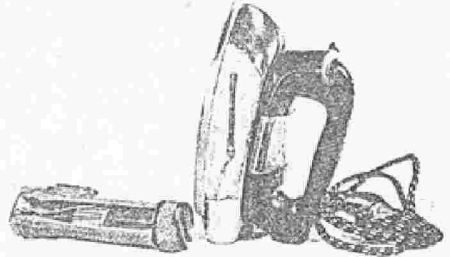

FIGURE 95. Booby trapped flashlight and steam iron.

This consists of an electrical system rigged into the flashlight or iron, designed to trigger the booby trap when electric switching is applied. The flashlight is a device often used by professional terrorists.

140

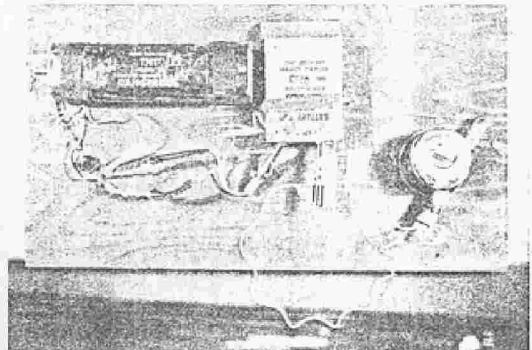

FIGURE 96. Door knob tilt device.

This bomb consists of a tilt switch attached to a door knob and is designed to fire the bomb as the knob is turned. The glass tube contains a conductive solution of salt water or copper sulphate and when tilted will bridge the electric leads to complete the firing circuit. Another variation of this device is to substitute a ball bearing in the glass tube which, when tilted, will roll down and complete the circuit.

141

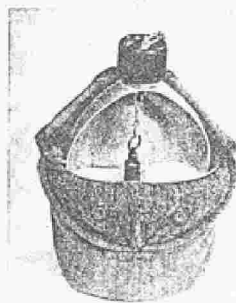

FIGURE 97. Booby trapped water canteen rigged with U. S. pull fuse to fire as cap is lifted.

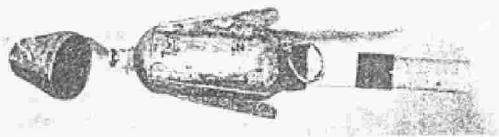
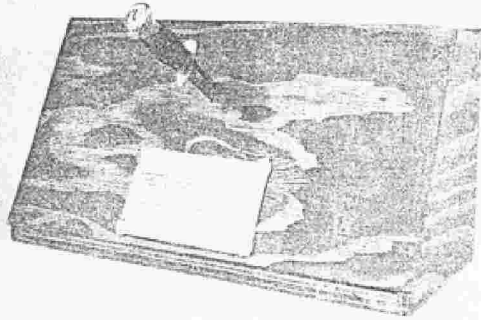

FIGURE 98. Algerian improvised hand grenade utilizing impact and base detonating fuses.

142



A very deceptive device consisting of a knife driven into a wall and rigged on the reverse side to fire the bomb by electrical means if the knife is withdrawn. The illustration shows the knife in position and the reverse side of the device wired electrically to fire.

143

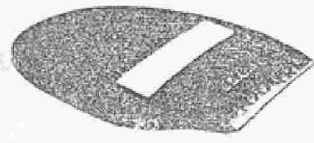

FIGURE 99. German explosive shoe sole.

Professional saboteurs during World War II used explosives manufactured in the form of shoe soles, rain capes, and even belts to escape detection. The detonating devices were often sewn into the belts or in the linings of the various garments. The explosive was called "nitroliit."

144



FIGURE 100. Booby trapped box with pull device

This device consists of a box containing a gun barrel, small arms bullet, and a pull initiated firing pin designed to fire into the chest or stomach of the victim as he opens the box. The device shown was actually employed in a large metropolitan city by an individual who was attempting to catch a burglar.

145

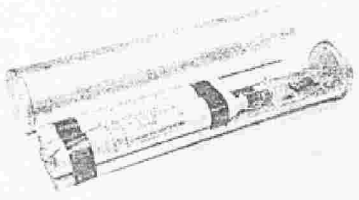

FIGURE 101. Thermal switch bomb.

This device consists of a bomb manufactured with a thermal



FIGURE 102. Knife booby trap.

switch designed to fire the bomb on application of heat or cold changes. The switch is made of a bi-metal strip much like the type used in a toaster or iron and is often obtained from these sources. The bomb is employed on the block of an auto engine, on a steam radiator or like heat producing device. It has been placed in freezers by inverting the switching to fire on application of lowering temperatures.

146

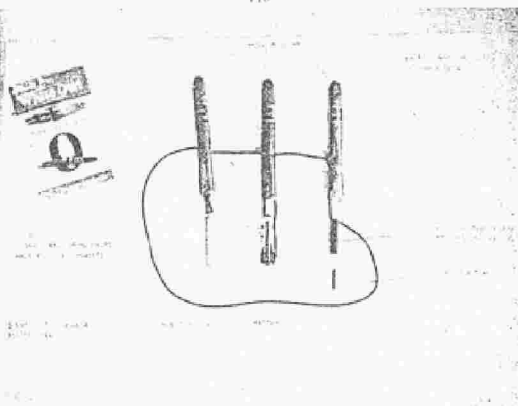

FIGURE 103. Cigar package bomb.

The cigar bomb illustrated was recovered in Canada during the wave of FALN bombings. The bottom of the package had been carefully opened and the five cigars were removed and followed out. Three of the cigars contained the firing circuit consisting of a sliding contact (filr switch) electrically fired by means of a miniature pen light battery. The other two cigars were filled with dynamite and the package was re-assembled and carefully glued at the bottom giving the impression of an unopened box. This bomb could have severed the hand of a man had it been initiated.

147

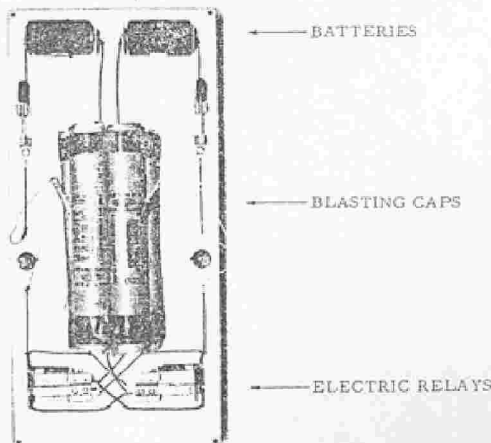

FIGURE 104. Long delay, collapsing, and booby trapped bomb.

This is perhaps one of the most dangerous circuits of the entire electrical group, next to a vibratory switch. It consists of two electric relay switches held open by the battery power alone. After the batteries drain off in power, the relays will close, firing the circuit. Meanwhile, if any one wire is cut, the circuit will collapse and fire. If either battery is removed, the circuit will collapse. To throw the expert off guard, one stick of dynamite has been hollowed out and a mercury tilt switch with a small pen light battery and cap is inserted. If the expert renders safe the main circuit and tilts the bomb it will fire. See Figure 105.

148

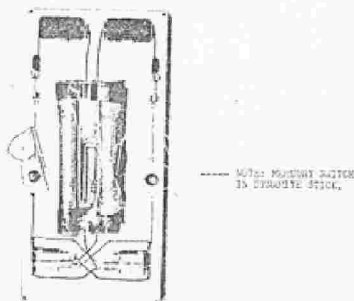

FIGURE 105. Long delay, collapsing, and booby trapped circuit.

This is the same circuit as explained in Figure 104. This illustration, however, shows the dynamite inverted to indicate the separate fuzing system contained in the hollow stick of dynamite. This circuit is very difficult and proves that a well-versed terrorist may go to great extremes to booby trap the expert. This bomb would be almost impossible to render safe once it were armed and functioning.

149

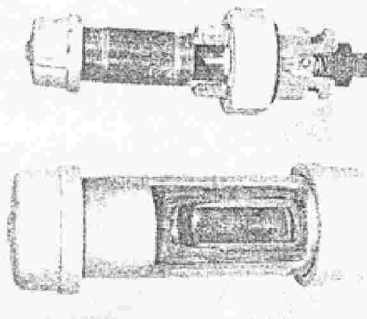

FIGURE 106. Pipe bombs using a wax (paraffin) delay unit.

The wax delay bomb is rather unusual but was actually used. The bomber in this case used pipes for his containers and carefully constructed spring-loaded firing pins in the interior, using wax to retain the springs and pins. The bombs were then placed on steam radiators or any heating unit and, as the wax melted, it would release the spring-loaded pin, exploding the bomb.

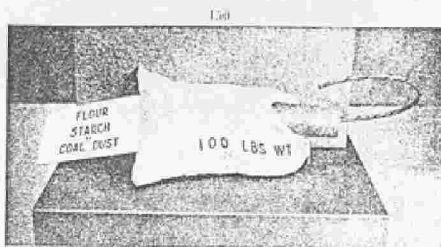

FIGURE 107. Dust initiator (dust bomb explosion).

This bomb is in wide use today by saboteurs, terrorists, and guerrillas because a tremendous explosion can be obtained using a minimum of explosives for initiation. It consists basically of a small amount of explosive and incendiary material embedded into the center of a "dust" cover. As the explosive detonates, it throws the dust about the area in fine powder and the burning incendiary ignites the dust yielding fantastic explosions. Flour, starch, coal dust, and powdered sugar are some covers in use. Certain liquid covers are also used: such as gasoline, alcohol, and propane.

151



FIGURE 108. "Atache" envelope bomb.

This bomb was carefully constructed, using miniature electric devices, and was sent to a Naval Atache in the large manila envelope shown. It consisted of a small electric micro-switch, pen light batteries, electric blasting cap, and plastic explosive molded to the cardboard backing. The pressure release micro-switch was installed at the top of the sealed manila envelope and would have fired at the instant the envelope was opened. A package inspecting X-ray unit discovered this bomb before it was opened.

152

This bomb was carefully constructed by an ordnance expert and is probably one of the most dangerous of all the illustrations shown. It consists of a clock timing delay, a clock firing delay, two pressure release microswitches (top and bottom), a mercury tilt switch, and a very sensitive vibratory switch. The entire circuit was wired in parallel which means that any initiation of the switches could fire the device. Meanwhile, the clock delay switch will close and fire the bomb as it reaches the proper time. The additional switches are known as a "protective" circuit. A most dangerous item.



FIGURE 109. Clockwork, long delay, anti-walkaround, booby trapped circuit.

153



FIGURE 110. Mouse trap (pressure release) bomb (electric).

The mouse trap bomb utilizes a common household mouse trap and, in this particular item, an electric circuit. The jaws of the trap have been carefully opened and are held open by the lid of the cigar box container. Any attempt to raise the lid will result in the spring-loaded jaws of the trap closing and firing the bomb. The mouse trap is quite frequently used by bombers as a switching device. The bomb is very sensitive as even unlatching the lid would result in the tight spring flinging the lid open.

154



FIGURE 111. Mouse trap bomb (percussion unit).

This bomb functions the same as the electric type except, in this case, the trap jaws utilize an improvised firing pin which is driven into an improvised small arms cartridge igniter setting off a non-electric blasting cap. The primer of the small arms cartridge, when struck by the firing pin, will transmit the flame to the blasting cap. A very versatile switching unit employed universally.

155

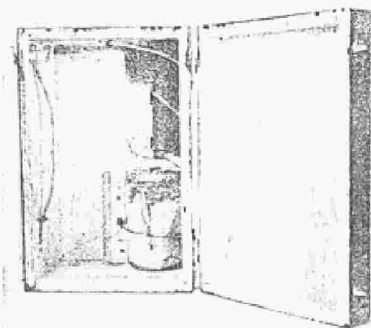

FIGURE 112. "Fruit jar bomb."

This bomb was given the nickname of "fruit jar" because the bomber in three known cases placed his explosives in such a jar. The illustration was reconstructed from a bomb that killed three postal workers in a large eastern city. The bomb was constructed with an electrical switch to fire the bomb as soon as the box latches were rotated. The bomb exploded as a postal inspector was examining the suspected box.

156

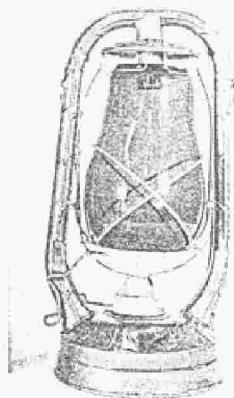

FIGURE 113. Lantern bomb.

A very simple, but effective, device employed during World War II. It consists of a kerosene lantern which is filled with high octane gasoline. As the victim lights the lantern it explodes violently.

157

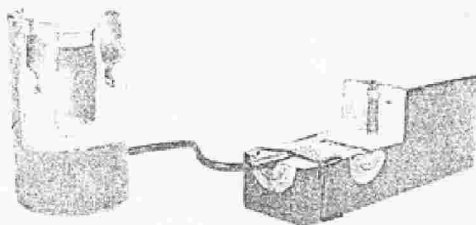
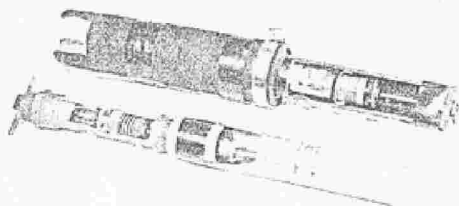

FIGURE 114. Long delay incendiary and explosive bomb.

The device shown was employed by German saboteurs during World War II and consisted of a sulphuric acid delay unit and an incendiary charge, coupled with an explosive charge to spread the incendiary over a large area. The sulphuric acid was placed in the small ml. bottle, with used paper, cork, or a rubber material in the cover. The center of the incendiary mixture contained potassium chlorate and sugar as the igniter. The explosive charge was connected by means of a time fuse to the incendiary. The acid delay was inverted as shown and would eventually eat through the delay material, igniting the incendiary.

158

FIGURE 115. *Top:* German altimeter bomb. *Bottom:* Improvised long delay bomb (chemical).

*Altimeter bomb:* A unique device used by the Germans. Consisted of a set of barometric bellows (expanding unit) and an electrical circuit. The bomb was placed in an aircraft and, as the plane ascended, the bellows expanded and fired the circuit.

*Improvised chemical delay:* A long delay bomb manufactured using acetone in the glass vial and a spring-loaded firing pin retained by a plastic washer. The acetone vial is crushed and will, after a delay time, soften the plastic washer releasing the spring-held firing pin. The strength of the acetone used and the temperature will determine the delay time, but six days or more is possible.

159

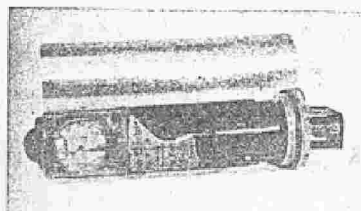

FIGURE 116. Manufactured time bomb.



The time bomb illustrated is a manufactured timing device consisting of two clocks and a battery power source contained in a waterproof container. It was manufactured for use by major oil companies in demolition operations but has been used by certain undesirables as a timing system for long delay bombs. The device is very accurate with delays to twelve hours. If one clock fails, the other will take over, insuring a detonation. This clock is called "the zero hour bomb."

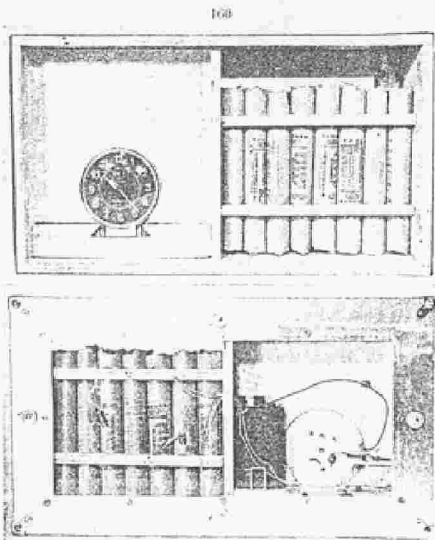

FIGURE 117. Suitcase clockwork delay bomb (front and rear views).

A very large bomb using a clock delay mechanism with the clothespin switching unit. The insulated wedge pull wire has been wrapped around the alarm setting stem and will fire as the stem rotates by pulley action. This device is hazardous as one can see in the front view. If any attempt is made to remove the clock from the case, it will pull out the clothespin wedge, firing the bomb.

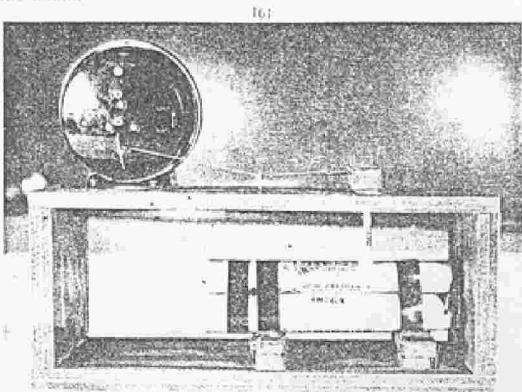

FIGURE 118. Clock work delay with U.S. pressure release fuse.

This bomb was constructed using a pulley system connected

to the alarm winding stem and connected by a fine wire to the release pin of a standard U. S. M-5 mine fuse. At the proper time, the alarm winding stem will rotate and withdraw the release pin of the firing device, causing a cocked firing pin to explode the bomb.

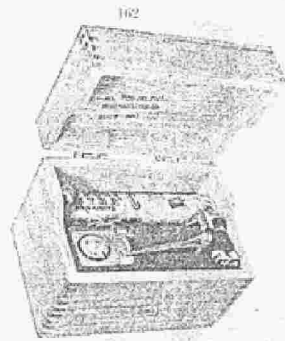

FIGURE 119. Index file (3x5) bomb.

This bomb was neatly constructed inside of a standard 3x5 index file box. A small Japanese timing unit, used by model airplane hobby shops, was constructed to release a spring-loaded electrical switch at the proper time. The electrical switch was spring-held by means of two rubber bands. This should indicate once again that clandestine items can be found anywhere and in almost any type of containers.

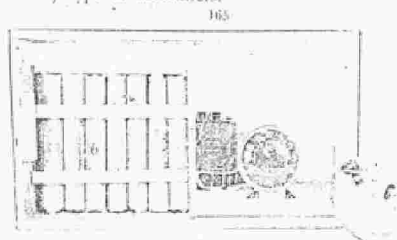

FIGURE 120. Suitcase bomb (clock work long delay).

Another variation of the previous clock units already illustrated. This device uses an electric circuit and the alarm winding stem has been insulated and set to close the circuit by means of simple rotation into an electrical contact. Suitcase bombs are quite frequently encountered by peace officers.

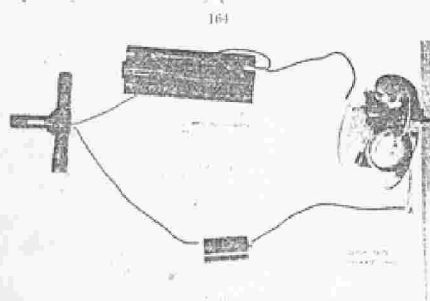

FIGURE 121. Clockwork delay and hoody trapped circuit.

The device shown was used in Canada by a terrorist organization. It consisted of a clock switch, dynamite, dry cell battery, and a small plastic "T" unit, which was sealed. This bomb was designed to throw the expert off guard as the little plastic "T" unit contained a mercury tilt switch, pen light battery, blasting cap, and enough explosive to sympathetically detonate the main charge, if disturbed. The large clock and main circuit appeared to be the prime fuzing system but, in reality, the small plastic device was self firing. A very deceptive booby trap.

165



FIGURE 122. Miscellaneous devices.

*Left:* Homemade hand grenade using plastic cigarette case and military grenade fuze.

*Right:* Improvised barometric bomb device was constructed using two balloons placed near two flexible electric switches. Theoretically, the balloons would expand when placed in an aircraft as soon as the aircraft ascended to altitude. The expanding balloons would force the two flexible metal switches together firing the bomb.

166

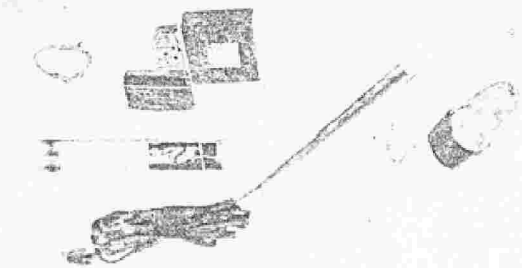

FIGURE 123. Miscellaneous devices.

*Left to right:* Co 2 cartridge bomb, Fish pond heater bomb, Cigar tube bomb, Cigarette lighter bomb.

Description:

**CO 2 cartridge bomb:** a CO 2 container filled with black powder and fused with a time fuze.

**Fish pond heater bomb:** a standard fish pond heater was found loaded with smokeless powder and designed to fire as the heater element was plugged into the electric wall current outlet.

**Cigar tube bomb:** a standard aluminum cigar tube rigged electrically to fire as the upper cap was removed, completing an electric circuit.

**Cigarette lighter bomb:** a very ingenious device consisting of a cigarette lighter filled with photoflash powder and fitted with a quick match fuze in place of the lighter wick. It was

designed to fire as soon as the flint was struck and could have been lethal to the victim.

167



FIGURE 124. Miscellaneous devices.

*Left to right:* Improvised zinc long delay unit, Booby trapped police whistle, Firefly incendiary devices, Clockwork long delay unit in cigarette package.

Description:

**Zinc long delay unit:** consists of sulphuric acid eating on a zinc plug to eventually drop into battery plates, creating an electric current flow.

**Booby trapped police whistler:** an abrasive coating on the whistle ball to create friction to a flash charge and main charge as the device is used.

**Firefly incendiaries:** gelatin capsule, filled with metallic sodium and calcium carbide. When submerged in water, or thrown into gasoline tank will create a violent explosion.

**Clock delay cigarette package:** self-explanatory.

168

## Chapter IX

### MILITARY MUNITIONS

#### BACKGROUND

A few years ago, an employee in a large bus depot in a major West Coast city hoisted up a serviceman's canvas clothing bag and slammed it down on a hand truck. An car-splitting explosion occurred, killing the worker immediately and blasting holes throughout the receiving room.

Military demolition experts assisting in the investigation determined the cause of the blast to have originated from a military fragmentation hand grenade. Two more grenades, live loaded, were found in the clothing bag which had housed the seat of the explosion.

Three war souvenirs, the guilty serviceman later testified.

In any one month span, most large metropolitan police departments are called on to check various military munitions: either discarded or found among war trophies. These range from Civil War items to modern complex items and, regardless of age, they are always considered lethal if live loaded.

This chapter will deal with a small cross section of military munitions intended for familiarization purpose only. The munitions shown and discussed are among those found most often in public areas.

Never underestimate the size of the munition because, in today's vast field, there are high explosive rounds the size of a rifle cartridge which can kill and maim.

Military munitions, until properly identified by a competent

169

military explosive ordnance disposal expert, should not be moved or touched as these items are extremely dangerous if fully armed or dud fired.

Large police units, having access to a bomb truck, may attempt to carry a military munition through inhabited areas of a large

vity, due to a false sense of security. This should not be done under any circumstances. Some military munitions are designed to penetrate many inches and sometimes feet of reinforced concrete or steel, as in the case of our large anti-tank mines.

The nearest U. S. Army Headquarters or military bomb disposal unit should be notified upon finding any U. S. or foreign military explosive item which cannot be properly identified. The multitude of complex arming and firing systems used by the military would fill volumes of books. It requires months of strenuous training to graduate a trained military bomb disposal technician and it is wise to leave military munitions to the military expert. A military expert assisting local law officers on this type of mission should be given all the assistance possible when he is performing a rendering safe procedure. The greatest problem today seems to be the gathering of the curious and lack of control of the spectators.

**CLASSIFICATION**

Military munitions for simple classification can be placed in the following groups:

1. Bulk explosives (demolition materials).
2. Chemical and biological munitions.
3. Projected munitions (artillery projected, etc.).
4. Placed munitions (land mines and booby traps).
5. Thrown munitions (hand and rifle grenades).
6. Rockets (ground and air).
7. Air dropped (bombs).
8. Guided missiles.
9. Underwater ordnance (sea mines, torpedoes, etc.).
10. Nuclear weapons (atomic bombs, etc.).
11. Improvised munitions.

170

**MILITARY MUNITIONS**

The following illustrations will show the general types of military munitions most encountered by peace officers.

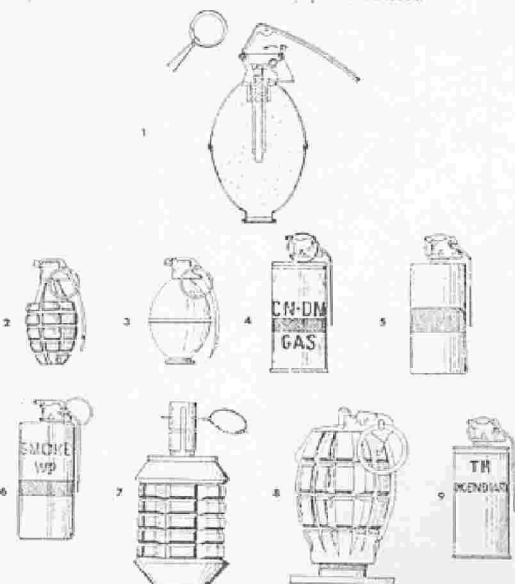

FIGURE 125. Military hand and rifle grenades.

171

1. Cross section showing striker release mechanism of a standard high explosive hand grenade.
2. Fragmentation hand grenade.
3. Inner wire wrapped fragmentation hand grenade.
4. Tear and vomiting riot control hand grenade.
5. High explosive concussion hand grenade.
6. Bursting smoke (white phosphorous) hand grenade.
7. Japanese fragmentation percussion hand grenade.
8. British fragmentation hand grenade.
9. Incendiary (thermite) hand grenade.
10. High explosive anti-tank rifle grenade (slope charge).

Most hand grenades used by all countries will incorporate a delay time of about 4 to 5 seconds from throwing time until bursting time for safety reasons. High explosive hand grenades will usually contain about 3-4 ounces of high explosive filler with a lethal bursting radius of about twenty-five feet and danger area of approximately fifty yards.

172

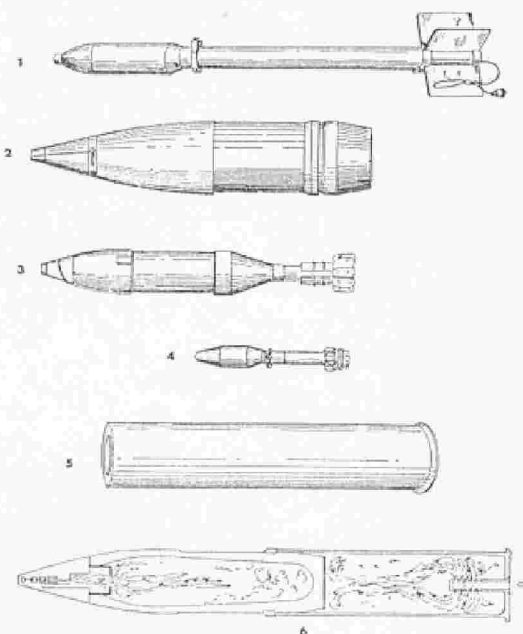

FIGURE 126. Projected munitions, military projectiles, etc.

1. High explosive rocket, air to air, or air to ground.
2. Artillery projectile (variable fillers).
3. High explosive mortar projectile.
4. High explosive anti-tank rocket (*barooka round*).
5. High explosive photo-flash cartridge.
6. Complex round of artillery type projectile showing complete firing train.

175

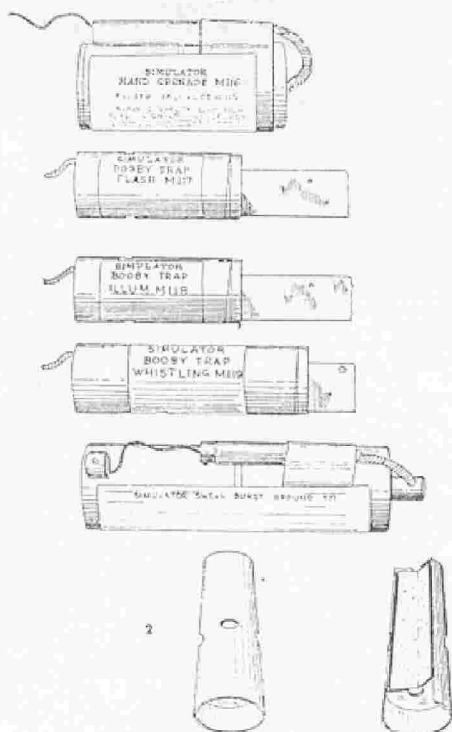

FIGURE 127. Military simulators.

1. General types of simulators used for training on field problems.  
 2. Military firecracker.  
 Note: These items should be handled with extreme care, if found, as they are very powerful in nature, and many of the fillets are extremely sensitive to heat, shock, or friction.

174

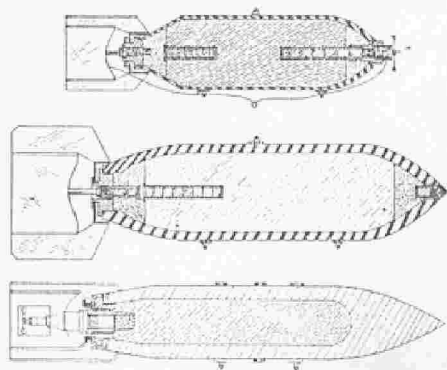

FIGURE 128. Dropped munitions (bombs for aircraft).

1. High explosive general purpose bomb.
2. High explosive venturium penetrating bomb.
3. High explosive armor penetrating bomb.

173

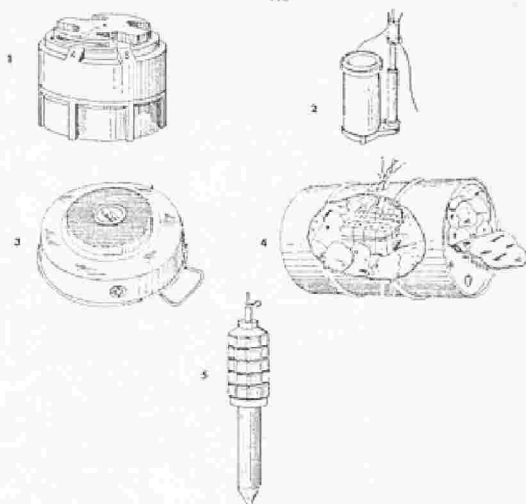

FIGURE 129. Military placed munitions (land mines).

1. Anti-personnel land mine filled with about one ounce of high explosive. Pressure of twenty pounds on the pressure plate will initiate the striker unit. A fulsant explosive of one ounce will almost shear a man's foot away.
2. Anti-personnel mine of the bounding variety. This mine, when initiated, will bound up into the air and detonate about six feet above ground with a fragmentation effect. A very deadly mine containing about one pound of filler.
3. Anti-tank mine utilizing the blast effect and filled with about twenty-one pounds of explosive. This mine will immobilize tanks which weigh up to 150,000 pounds.
4. Improved mine (dongasse). This particular version uses rocks. However, various forms of incendiaries are also used.
5. Russian fragmentation land mine, using a stick for ground employment.

176

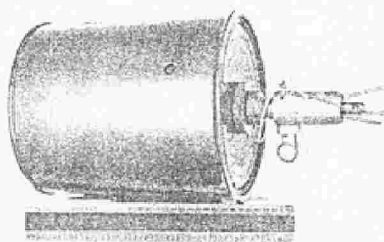

FIGURE 130. U. S. anti-personnel fragmentation and bounding mine.

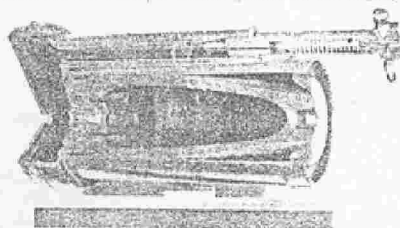

FIGURE 131. U. S. anti-personnel fragmentation and bounding mine.

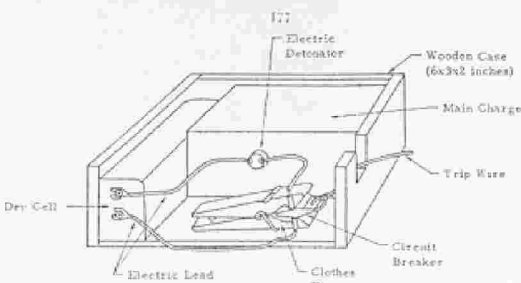

FIG. 177. Improved mine (pull initiated).

This mine utilizes the clothespin switching device and an electric circuit for firing. The insulated wedge is placed between the jaws of the pin and a slack wire or cord is attached. As the wire is pulled, it withdraws the wedge allowing the circuit to close.

The clothespin switch is employed universally by saboteurs and terrorists in a number of varied ways. The switch can be assembled to initiate devices on pull, pressure, pressure release, and tension release initiating actions.

#### CHEMICAL MUNITIONS, MIXTURES, AND AGENTS

This chapter is designed for familiarization purposes only, inasmuch as the peace officer should never attempt rendering a safe procedure or disposal of any military chemical munition. Even expert chemical disposal personnel must exercise the utmost precaution while disposing of chemical agents, due to certain war agents of a lethal nature. The disposal area, protective clothing, and weather conditions must be perfect or a disaster could occur. Chemical agents could be placed in nearly any military munition and this is the prime reason why the military should be contacted regarding all military munitions.

The marking systems and color coding symbols on military

176

munitions are subject to changes periodically, and what may appear to be a normal high explosive artillery projectile could, in reality, contain a casualty gas capable of killing hundreds by inhalation of its vapors alone. This fact, too, explains why a military munition should not be transported by any metropolitan bomb squad through an incorporated area. As a matter of record, many World War I artillery projectiles containing "mustard" gas have been recovered in civilian homes, as war souvenirs.

Chemical agents exist under most conditions as solids, liquids or gases, and vary in effects from highly toxic and lethal, to no effect at all. They are classified in one form by their tactical uses, as:

1. **Casualty Gases**—Capable of producing injuries or death in field concentrations.
2. **Training and Riot Control Gases**—Have a temporary irritating or incapacitating effect.
3. **Screening Smokes**—Produce an obscuring effect.
4. **Signaling Smokes**—Used to convey a message and are usually colored.
5. **Incendiaries**—Used to start fires or create burn casualties.

#### Physiological Action

War gases are generally classified by their physiological actions, as:

1. Choking gases.
2. Blood gases.
3. Nerve gases.
4. Blister gases.
5. Vomiting gases.
6. Tear gases.
7. Combinations of the above.

**Choking gases.** These gases injure an unprotected man by attacking the respiratory tract (nose, throat, and lungs), and certain gases of this group will literally choke a man to death and, because of the lack of oxygen, will cause the lungs to fill with liquid. If not treated in time, the man will die "in the liquor of his own blood." The choking gases are listed as:

179

1. Phosgene (symbol CG).
2. Diplosgene (symbol DP).

**Blood gases.** These gases are absorbed into the body primarily by breathing and are extremely lethal. They literally shut out the transfer of oxygen from blood to the body tissue and will kill within minutes after contact. They are listed as:

1. Hydrogen cyanide (AC).
2. Cyanogen chloride (CK).
3. Arsine (SA).

**Nerve gases.** These gases are perhaps the most rapid and lethal of the casualty agents and serve to upset the balance of a man's nervous system. They are appropriately named "nerve gases" and will bring death within seconds to minutes if inhaled or contacted in any form. They are listed by name as:

1. Tabun (Ga).
2. Sarin (GB).
3. Soman (GD).

**Blister gases.** The blister family are used for casualty effects and will affect the eyes, the lungs, and cause painful blisters on the skin. They are, for a large part, manufactured from arsenicals and many blister casualties from World War I are still confined in hospitals because of the damage to their lungs and skin tissues. These gases are listed as:

1. Mustard (H).
2. Distilled mustard (HO).
3. Nitrogen mustard (HN1-2-3).
4. Lewisite (L).
5. Mustard-lewisite (HL).
6. Phenylchloroarsine (PD).
7. Ethylchloroarsine (ED).
8. Methylchloroarsine (MD).

**Vomiting gases.** These gases are normally solids which, when heated, will vaporize and form toxic aerosols to cause vomiting and much discomfort to the victim. These agents are normally used in riot control and are often used in conjunction with tear gases. If released in doors and in sufficient quantities, the vomiting gases could cause serious illness or death. They are:

180

1. Diphenylchloroarsine (DA).
2. Adamsite (DM).
3. Diphenylcyanoarsine (DC).

**White phosphorus.** A waxy solid chemical which reacts violently on contact with air or oxygen. The odor of white phosphorus is similar to that of burning matches. Prolonged exposure to white phosphorus is toxic and gas masks should be worn in a saturated area. Protection against white phosphorus is afforded by a solution of copper sulphate and burning particles on the skin may be smothered by water or mud packs.

White phosphorous is used in military grenades, projectiles, and rockets. It has also been used by saboteurs and fire bugs as an effective incendiary device. White phosphorous in a military munition could be very hazardous as a high explosive burster may be used to spread the agent. The military and chemical symbol for white phosphorous is WP.

**Sodium.** Often used in military fire bombs as an igniter. Sodium bears the chemical symbol NA. This chemical reacts violently upon contact with water or moisture. Sodium fires should be smothered by use of soda ash, dry sodium chloride, or graphite. Sodium is often termed metallic sodium and is a light soft silver white metal in appearance. Due to the violent nature of this metal, it is usually transported submerged in kerosene, benzene, or other similar fluids. Metallic sodium has also been used as an incendiary by saboteurs and the like. In military fire bombs, it is possible to find a white phosphorous igniter and a sodium igniter making fire fighting rather difficult.

**Tear gases.** These are used for riot control and cause a flow of tears, discomfort, and irritation of the skin. They normally leave no after effect but, if used in great quantities indoors could cause death. They are listed as:

1. Chloroacetophenone (CN).
2. CNG (Chloroform and CN).
3. CNS (Chloroform, Chloroform and CN)
4. CNB, 181
5. Bromobenzylcyanide (BBC).
6. CS.
7. CN DM (Chloroacetophenone adamante).

**Miscellaneous gases.** Two agents used during World War I and shortly thereafter were:

1. Chlorine.
2. Stimulated H.

**Improvised toxic gases.** Many harmful gases may be prepared from simple substances purchased from drug stores, groceries, farm stores, etc. For example, some types of rat poison and silver polish may contain sodium or potassium cyanide, which releases the deadly hydrogen cyanide gas on contact with acids. Hydrochloric acid may be purchased at a drug store under the name "muriatic acid." Death may result from a few minutes exposure to low concentrations of this gas; the predominate symptoms being labored respiration, paralysis and convulsions.

Sodium bisulphite may be purchased from stores selling fertilizers and this, mixed with battery acid (sulphuric), releases sulphur dioxide, which is a colorless, non-flammable gas with a strong suffocating odor.

A simple mixture of household bleach (sodium hypochlorite) and vinegar will release chlorine gas, dangerous to inhale, resulting in death rapidly after a short exposure. This mixture is particularly hazardous as both are commonly used for household cleaning, and death may result from mixing the two unknowingly. However, the housewife usually uses these compounds in small quantities in a bucket of water, which lessens the danger.

Possibly the easiest method of improvising a toxic gas is to drip carbon tetrachloride (dry-cleaning fluid) on a hot surface, such as a hot plate, furnace, etc. Not only is carbon tetrachloride poisonous, but phosgene is produced by this technique. Phosgene is a war gas, and is an insidious poison as it is not irritating immediately and fatal concentrations may be inhaled by those who do not recognize the odor.

## 189 HYPERGOLIC MIXTURES

The word hypergolic means "self-igniting," or spontaneously inflammable. A hypergolic mixture is one that will burn or explode on contact without the necessity of an outside igniter. Rags soaked in motor oil will ignite rapidly in the presence of battery acid. The reaction will be especially rapid if potassium nitrate (fertilizer) is added. Ammonium nitrate (fertilizer) may be dissolved in water into which newspaper is shredded. This pulp is spread out and dried. Battery acid added to this will result in a fire.

### STINK BOMBS

Flowers of sulphur can be purchased at a drug store. If this chemical is heated with iron filings, iron sulphide is produced. This releases hydrogen sulphide in the presence of battery acid. This is a flammable gas with the persistent odor of rotten eggs, and is highly toxic, as well. Some depilatory preparations contain sodium sulphide which is quite repulsive when spread on door knobs, canned goods, etc. Acid added to such preparations causes the evolution of hydrogen sulphide gas.

### CONTRIVED EXPLOSIVE DEVICES

Explosive devices may be found in almost any form. The characteristics common to all are a closed, rigid container, such as a pipe with a cap on each end, a sealed oil drum, etc. An igniter may be improvised from a large rifle or shot-gun shell, or the device may be wired into the electrical system of a car, boat, or building. Explosive devices are often wired to the starter system of a car, but may be wired into any system with an "On" switch, such as the radio or heater. A fuel and oxidizer are required for the explosive and may be a mixture of the following:

#### Oxidizers:

- Ammonium nitrate (fertilizer store).
- Potassium permanganate (drug store, tropical fish supplies, photographic store).
- Potassium nitrate (fertilizer store, drug store).
- Potassium dichromate (drug store, photographic store).

183

- Ammonium, potassium or sodium perchlorate (chemical supply house).
- Ammonium, sodium or potassium thiosulphate (photographic supplies).
- Sodium perborate (teeth whiteners).

#### Fuels:

- Fuel oil, lubricating oil or grease (garages).
- Cotton seed oil, linseed oil, tung oil (paint store).
- Lard, crisco, peanut oil, any cooking oil (grocery).
- Sulphur (drug store).
- Charcoal (drug store).
- Sugar (grocery).

The proportions are usually 80-85 per cent oxidizer, 20-15 per cent fuel. All of these ingredients are readily accessible to everyone, and explosive devices manufactured from them (and many others) may be commonplace, or may be marvels of ingenuity. A high school knowledge of chemistry can open the door to many exotic types of explosive devices.

### SIMULATORS

The majority of simulators are classed among the pyrotechnic group and range from simple whistle noise makers to powerful photoflash or black powder charges capable of maiming and

killing. The devices contain expelling charges designed to propel the items to great heights for an air burst or may burn with intense heat to produce various illuminating flares at ground level. Peace officers have encountered many of these devices which have been left by military units using maneuver areas (war games) adjacent to metropolitan cities. In many cases, the items are treated lightly because of the flimsy containers or term "simulator" stamped on the item.



FIGURE 135. Large projectile simulator. Explosive force nearly equivalent to one-half pound of TNT.

The container materials are normally of cheap construction, such as cardboard, plastic, or light aluminum bodies but the fuzing or firing system can be quite complex and dangerous, if not handled properly. Should these items be found, they should be treated the same as any other military munition and military bomb disposal personnel should be notified for rendering safe procedures and disposal.

The following are some of the more common simulators and like devices of the smaller varieties. The military, however, uses varieties as large as a 55-gallon oil drum to simulate an atomic bomb burst with fantastic blast and incendiary capabilities.

1. Simulators, gunflashes.
2. Firecrackers, M80 and M82.
3. Charges, smoke, and shell burst.
4. Simulator hand grenade.
5. Photoflash cartridges.
6. Flash booby-trap simulators.
7. Whistling booby-trap simulators.
8. Illuminating simulators.
9. Atomic bomb simulators.
10. Practice charges for land mines.
11. Assorted propelled ground signals.

185

#### PROTECTION AGAINST CHEMICAL AGENTS

For the law officer, the best protection from a suspected military chemical munition is to evacuate the area for a safe distance and call a military explosive ordnance disposal unit without delay. The protection required for chemical munitions, depending on their type, ranges from a simple gas mask to full protective (impermeable) clothing. The areas of evacuation could range, depending on the munition and its condition, from twenty feet to five miles. The detection and identification could range from simple observation to complex chemical kits. The area surrounding the munition may require certain decontaminating procedures before any person can re-enter the area and this requires technical training. Disposal ranges from detonation to controlled burning procedures under almost ideal conditions.

The above statements lead to only one conclusion: due to the infrequent encounters of chemical munitions, they should be handled only by experts. The military field manual entitled "Military Chemistry and Chemical Agents," listed in the reference section of this book, provides detailed information pertaining to military chemical agents and munitions for those interested.

Rapid developments throughout the world have ushered in the possibility of a saboteur transporting and emplacing a "suitcase" type of nuclear bomb, capable of destroying vast sections of any metropolitan or military area. This section contains, for the most part, a statement released by the President of the United States in 1953 outlining the general identification features and component parts of most nuclear devices.

Large metropolitan police departments should maintain certain radioactive monitoring devices (radial instruments) for preliminary investigation of a suspected nuclear device and all members of the bomb squad should be thoroughly trained in the hazards of nuclear radiation and contamination. No attempt should ever be made on the part of a civilian peace officer or bomb squad to render safe a device of this nature and, should a suspected nuclear device be encountered, the proper authorities as outlined by FBI Director, John Edgar Hoover, should be notified without delay.

This type of device would be given the highest priority of attention among all the categories listed, due to its devastating effect and the high security classification connected with these weapons.

The following letter from the Department of Justice will best explain the general unclassified nature of atomic (nuclear) bombs.

#### UNITED STATES DEPARTMENT OF JUSTICE FEDERAL BUREAU OF INVESTIGATION

Washington 25, D. C.

January 1, 1954

#### ALL LAW ENFORCEMENT OFFICIALS

On December 15, 1953, the White House released a statement by the President requesting that all enforcement officers, both Federal and State, report all information relating to violations of the Atomic Energy Act to the nearest field representative of the Federal Bureau of Investigation. A copy of the statement by the President is attached. There is also attached for your information a description of atomic devices and component parts, the release of which has been approved by the Atomic Energy Commission, the National Security Council, and the President in order that you may be better able to recognize atomic devices or parts of atomic devices which might come to your attention.

The President and the National Security Council have designated certain Explosive Ordnance Disposal Units operating under the jurisdiction of the Department of the Army as having the responsibility for discerning any atomic weapon. The disposal of discernible fissionable weapons and the disposal of fissionable material are by law the responsibility of the Atomic Energy Commission. Therefore, it is suggested that information regarding fissionable material or atomic weapons be reported promptly to the nearest representative of the Federal Bureau of Investigation and that no attempt be made on the part of an individual law enforcement officer to dismantle an apparent atomic device.

Very truly yours,  
JOHN EDGAR HOOVER  
Director

Attachment

187

December 21, 1953

#### INFORMATION FOR RELEASE TO REPRESENTATIVES OF DULY CONSTITUTED LAW ENFORCEMENT AGENCIES

##### Description of Atomic Devices and Component Parts

In order that citizens of the United States may intelligently assist in the defense of our country, they should have sufficient information regarding atomic weapons to enable them to recognize bombs or parts of bombs



which might be smuggled into the United States by enemy agents. It is impossible to describe exactly what a foreign atomic bomb will look like. On the other hand, it is possible to explain the basic ideas which will govern their design. For this explanation it is then possible to designate and describe those materials which must be essential to the construction of any atomic bomb.

Atomic explosion results when (1) certain amount of fissionable material in two pieces or more are brought quickly together to form one piece of such material and when (2) a certain amount of fissionable material is quickly made more dense by squeezing it together. The important thing about each of these methods is that masses of fissionable material must be placed into rapid motion. We know that high explosives are capable of giving any material such necessary rapid motion.

In the first case we would look for some kind of a gun barrel device using high explosive to blow one piece of fissionable material from the breech end of the gun through the barrel into another piece of fissionable material firmly anchored in the muzzle end of the gun.

In the second case we would look for a device using high explosive to squeeze fissionable material. To explain how such a device will work we must understand what is meant by "implosion." The significance of the word explosion is familiar to most people. Implosion signifies a bursting inward, as contrasted with the bursting outward of an explosion. In order to obtain an implosion however strange it may seem, explosive material is necessary. The scientists who worked on the first atom bomb needed an implosion in order to compress nuclear material enough to get an atomic "explosion." They solved their problem by forming a large sphere of explosive material. In a hole in the center of this sphere they placed the fissionable material they wanted to squeeze. Then instead of using a gun detonator to ignite the explosive sphere, they placed many detonators around it. These detonators were connected electrically in such a way that they could be fired simultaneously. If only one detonator had been used, one can easily understand that the sphere, having been ignited at only one point, would have exploded in the ordinary way; that is, with the exploding wave, which is another way of saying a fast burning wave, burning through the sphere from one side to the other. However, with many detonators igniting the sphere from all sides, the fast burning wave is essentially spherical in shape and burns inward toward the center of the sphere. When this fast burning imploding wave reaches the sphere of fissionable material, this mass has no place to be pushed except in upon itself and is thus compressed.

188

We have now explained very simply the basic ideas which govern atomic bomb design. Looking back at these ideas, we note that two essential features of the gun-type device are the gun barrel itself and fissionable material, and two essential features of the implosion-type device are high explosive charges that could be used to build a sphere and again fissionable material. We say by this that we will be able to help protect ourselves and our country, if we can recognize any one of three essential components; namely:

1. Fissionable material.
2. Gun barrel type device.
3. High explosives for implosion.

In order to help us in our recognition of these essential components we must learn something about them.

Fissionable material is uranium and or plutonium which are extremely heavy metals weighing half again as much as lead of the same size. Fifty pounds of these fissionable materials would be approximately five inches in diameter, is shaped as a sphere—about the size of a softball. Since both of these metals can be coated with other metals or plastics and can be machined into all sorts of shapes, we should be especially alert regarding any article that is extremely heavy for its size. Pieces which might be smuggled would probably be of a size that could be carried on the person.

The gun barrel type device will probably be made of steel. The diameter of the bore of such a gun barrel would probably not be less than two inches or more than ten inches. With such a range of inner diameters for the bore, we may expect the outer diameter of the gun barrel to range from about six inches as a minimum to about twelve inches as a maximum. Both ends of the barrel may be closed by heavy black-type devices so that the bore of the gun will not be visible. It is possible, of course, that the gun tube and the two heavy blocks may be visible. The fissionable material for the gun-type weapon may be concealed within and around at the ends of the gun barrel or it may be carried in separate packages for later assembly within the barrel. The length of the entire device need not exceed about two and one-half feet.

The high explosives of implosion will probably be in specially fabricated shapes one side of which will be a part of a spherical surface. Most high explosives are light tan in color, have a soapy feel and one half again as heavy as an equal quantity of water.

None should peace officers ever become involved in an aircraft crash suspected of carrying a nuclear device, extreme precaution should be taken to prevent the curious from approaching the vicinity. If the aircraft is burning, personnel should be evacuated upwind from the smoke, and until proper authorities arrive no one other than fire fighters should be allowed within 1000 feet of the aircraft. Fire departments should also be trained in the proper procedures to fight this type of fire, due to the explosive haz-

ards involved. There are also respiratory hazards involved should too much smoke be inhaled during the fire.

189

## CIVIL WAR ORDNANCE

The majority of our citizens who daily view the triangular mounds of cannonballs in public parks feel that these were all harmless solid shot. The truth is that a vast majority of Civil War ordnance was filled with highly explosive bursting charges consisting of black powder, the most dangerous explosive known. Black powder is extremely sensitive to heat, shock, and friction and is just as capable of exploding today as the day it was loaded some 100 years ago.

In 1959, a military explosive ordnance disposal team in one of the southern states received a call from a local peace officer to pick up a "useless" old cannon ball. Examination of the item revealed a little plug called a "Bornum time fuze" indicating the ball to be live-loaded and deadly.

The constable was quite alarmed when the experts explained the nature of this item and the officer stated that a little old lady had been using the cannon ball as a door-stop for years. The local newspaper ran an article on this item and during the next thirty-day period over seventeen similar explosive Civil War items were turned in by local townspeople.

Another incident which caused alarm to the bomb disposal experts in a southern state was their visit to a historical battle field museum. According to the incident report, they were viewing a beautiful collection of Civil War artillery rounds located in a show case and suddenly discovered a highly explosive "Parrot Round" among the collection. Here in a museum where thousands of men, women and children visit each month was a munition capable of hurling razor sharp fragments for blocks around. The curator was notified and further examination of his collection revealed twelve more fully loaded explosive items. Figure 134 indicates actual proof of the sale of live Civil War items in a battle field area. This is truly amazing because the hot ash from a cigarette on the fuze could cause this round to explode violently.

190

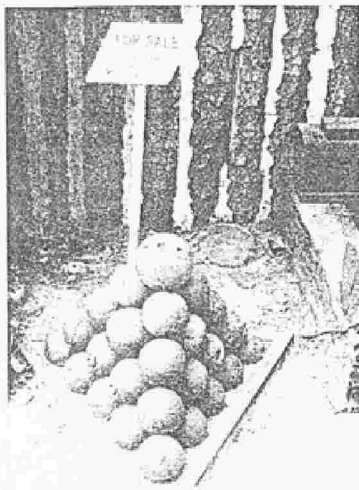

FIGURE 134. Sale of explosive-loaded Civil War rounds.

The Civil War era ushered in many different types of highly

explosive ordnance items such as hand grenades, rockets, torpedoes, artillery rounds, and land mines. There were many foreign and experimental items used during this period which are still unidentified today, even by the experts. These items are being uncovered and turned in daily throughout the southern states and military disposal experts treat them with the greatest respect due to the sensitive nature of the black powder fillers.

Black powder was not the only explosive used during the period of 1861-1865, and certain items recovered today have an unknown filler.

We do know that fulminate of mercury was used in certain

191

fuzing systems and gun-cotton dates back to 1846 and may have been used in experimental items. Certain nitro-cellulose products were also available during this period and certain Civil War ordnance could now be hyper-sensitive, due to age and certain reactions with metal containers.

Civil War and other ordnance enthusiasts today pay high prices for ordnance originating during this period, live loaded or not, and many "basement" collections throughout major cities contain sensitive and highly lethal items which can explode from the slightest application of heat, shock, or friction.

Bomb disposal units on occasions have attempted to inert Civil War items for museum collections by drilling the items under water or by applied burning techniques, but even these methods are considered highly dangerous, and the fuzes in most cases cannot be extracted due to age and corrosion. Charles Newhouser, listed in the reference section of this book, is perhaps one of the foremost living authorities on Civil War Explosive Ordnance and can be contacted by correspondence if technical

192

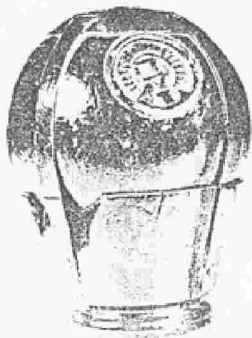

FIGURE 135. Civil War case shot round, filled with black powder and fuzed with a time fuze (Bormann).

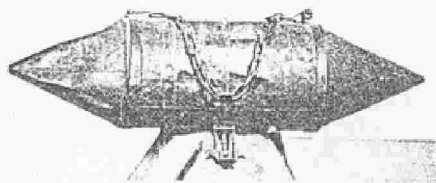

FIGURE 136. Civil War Confederate torpedo.

Fuze: Contact or pressure chemical.

Filler: Black powder.

Remarks: The Confederates made more use of mines and torpedoes during the Civil War than the Union and employed this type as moored, floating, or electrically initiated.

data is required. The American Ordnance Association, also listed in the reference section, maintains books and data on ordnance of this period.

The following illustrations and general data will show a good cross section of the explosive items used during the Civil War period. A good majority of Civil War ordnance may be transported and disposed of by civilian peace officers if care is exercised. However, if any doubt exists, a military expert or civilian Civil War collector should be consulted.

193

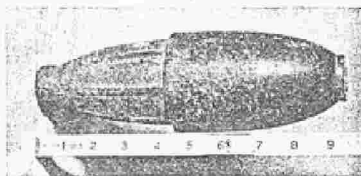

FIGURE 137. Schenck shell.

Fuze: Percussion, combination or time.

Filler: Black powder bursting charge.

Remarks: Issued in case shot, solid shot, and was considered one of the most popular projectiles during the Civil War.

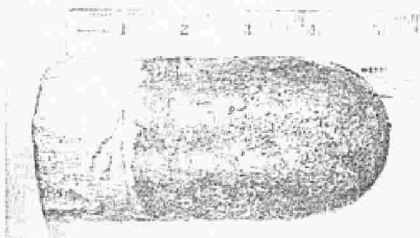

FIGURE 138. Confederate sabot projectile.

Fuze: Time or percussion.

Filler: Black powder bursting charge.

Remarks: Constructed in solid shot or bursting types and used a lead sabot on the base which expanded and engaged with the grooves of the gun barrel. This action imparted a stabilizing twist to the projectile.

194



FIGURE 139. U.S. Ketchum grenade.

Fuze: Percussion.

Filler: Black powder bursting charge.

Remarks: The most common Civil War hand grenade. It consisted of a dart shaped body with wood and cardboard stabilizing fins. This was a hand thrown grenade.

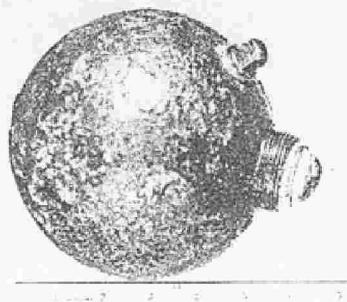

FIGURE 140. Confederate land mine.

Fuze: Pressure initiated.  
 Filler: Black powder bursting charge.  
 Remarks: This mine was constructed from a smooth bore projectile and a special fuze.



FIGURE 141. English Whitworth bolt.

Fuze: Brass for adaption of time or percussion fuzes.  
 Remarks: Constructed in solid shot (bolt) and shell (bursting) types.



FIGURE 142. Civil War rocket.

Fuzing and firing data: Unknown but appears to be solid shot.

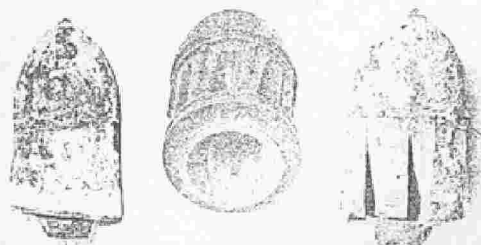

FIGURE 143. U.S. James shells.

Fuze: Percussion.  
 Filler: Black powder bursting charge.  
 Remarks: Also issued in solid shot.

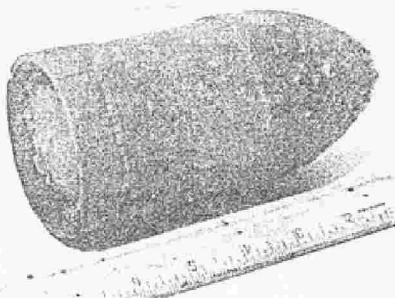

FIGURE 144. Confederate reel shell.

Fuze: Percussion or time.  
 Filler: Black powder bursting charge.  
 Remarks: Also found in solid shot and case shot. One of the most common Confederate projectiles.

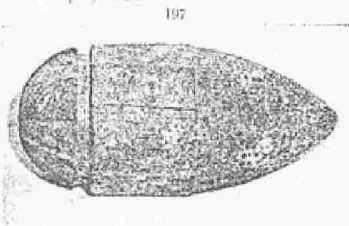

FIGURE 145. Dahlgren projectile.

Fuze: Unknown.  
 Filler: Unknown (types found inert).  
 Remarks: Federal and Confederate versions of this round exist. The Dahlgren is a very rare projectile and is seldom found today.

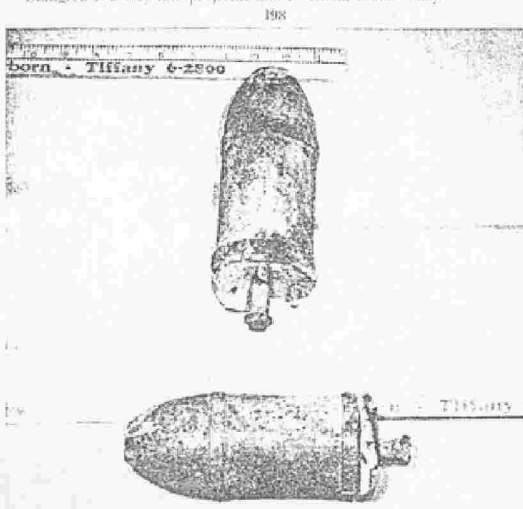

FIGURE 146. Confederate closed shell.

Fuze: Time and percussion.  
 Filler: Black powder bursting charge.  
 Remarks: Also issued in solid shot and case shot. This round is often difficult to identify due to components missing after firing.

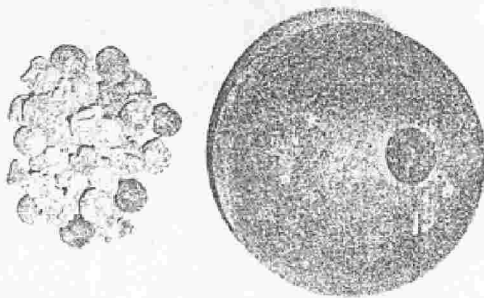

FIGURE 147a. Civil War case shot.

Fuze: Bottom or paper time.

Filler: Black powder bursting charge with lead balls embedded in matrix.

Remarks: Also issued in solid shot and shell.

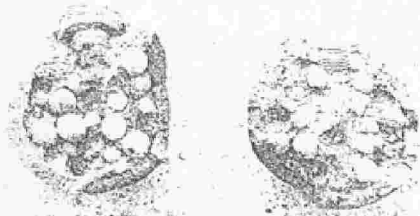

FIGURE 147b. Cannon case shot. Lead balls and matrix shown.

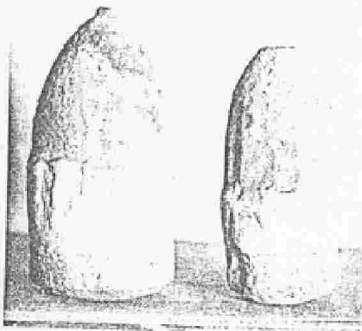

FIGURE 148. U. S. Hotchkiss shell.

Fuze: Percussion or time.

Filler: Black powder bursting charge.

Remarks: Also issued in case shot and solid shot. One of the most popular during the Civil War.

#### TRANSPORTATION AND DISPOSAL OF CIVIL WAR MUNITIONS

It is permissible, in most cases, for metropolitan peace officers to transport and dispose of Civil War munitions, if they can be positively identified as to type, and if care is exercised.

When transporting Civil War munitions, they should be car-

ried under water to minimize the black powder hazard, and the bed of the vehicle should be cushioned with sand bags to prevent excess shock. For disposal, a commercial jet perforator (shape charge) equivalent to a military MK 3 size should be used and, if possible, aimed at the fuze section. This will insure a good high order type of disposal and is preferred over merely counter charging the round.

The case thickness of most Civil War rounds does not lend to counter charging (blasting) with bulk explosives as a good marriage of the explosive counter charge cannot be obtained. Many times the round will be disintegrated, due to excessive heat, will sit and smoulder creating a "cook-off" hazard minutes later. Deep penetration with a shape charge will insure positive disposal unless the black powder is completely moisture soaked. If in doubt as to type of disposal, a military expert should be called in. Under no circumstances should stripping or inerting procedures be attempted on these items, due to the sensitivity of the black powder used as a main charge. Many collectors desire to retain these rounds, due to their monetary value, but these rounds are lethal and contain the most dangerous explosive known to man, "black powder."

#### Chapter X

### EMPLOYMENT, MATERIALS, AND SUPPLY OF CLANDESTINE AND SABOTAGE DEVICES

THE following chapter deals primarily with the personnel or agencies employing clandestine or like devices, the various supplies and sources of supplies and the prime targets against which these machines or materials are used. In addition, the last section of this chapter is devoted to the problem of analyzing a bombing which is closely related to the perpetrator and his source of supplies or motive.

#### PERSONNEL AND AGENCIES WHO MAY EMPLOY CLANDESTINE DEVICES, IMPROVISED EXPLOSIVES, OR SABOTAGE DEVICES

##### 1. Military

- a. Special Forces.
- b. O.S.S. Units.
- c. Engineers.
- d. Reconnaissance Units.
- e. Pathfinders.
- f. Raiders.
- g. Paratroopers.
- h. Counter Insurgency Units.
- i. Guerrilla Units.
- j. Military Saboteurs.
- k. Escape and Evasion Units.

##### 2. Civilian

- a. Crime syndicates.
- b. Racial groups.
- c. Safe-crackers, or criminals.
- d. Psychotics and firebugs.
- e. Rival labor groups.
- f. Professional saboteurs and agents.
- g. Terrorists.
- h. Juveniles (experimenting).

### CONTAINERS AND MATERIALS USED IN THE MANUFACTURE OF DEVICES

1. Pipes and tubes—Probably the most common items used because of their availability and because they are easy to seal tight for sustaining a fast burning rate. Using the most simple gunpowders and time fuses, they can be improvised into a very lethal bomb capable of a devastating explosion and lethal fragments.
2. Suitcases.
3. Soap dishes (plastic).
4. Cigarette boxes.
5. Rubber hoses.
6. Carbonated gas cartridges (CO<sub>2</sub> bottles).
7. Bottles and jugs.
8. Tin or metal cans.
9. Multiple cloth or plastic layers—Often, cloth or plastic is used by filling an inner layer with explosive and a wick or fuse and then submerging it in glue. As the inner layer dries, additional layers are dipped in glue and allowed to dry until the entire bomb is a compact, well-sealed unit.
10. Electric appliances—Widely used because they are deceptive and easy to assemble using an electric power source for ignition or detonation. Many appliances such as irons, toasters, etc. also provide their own heat source.
11. Fruit baskets (Latin countries).
12. Containers with magnets—<sup>204</sup> Assorted containers are often assembled with magnets to provide a handy means of attaching the item to metallic objects such as autos, etc.
13. Wax containers.
14. Plaster of Paris containers.
15. Wrapped packages (gift wrap, etc.).
16. Assorted shell casings and cartridges.
17. Butane or propane tanks.

### EMPLOYMENT (PRIME TARGETS)

The following are perhaps the most prime targets, based on previous teachings and doctrines. However, anyone could become a target as a result of anger or heat of passion.

1. Banks.
2. Alarm and protective systems.
3. Power supply.
4. Water supply.
5. Gas supply.
6. Radio stations and equipment.
7. Communications centers.
8. Shipping and harbor facilities.
9. Oil and steel industries.
10. Aircraft industry.
11. Railroads.
12. Bridges.
13. Grain elevators.
14. Military installations.
15. Automobiles—Perhaps the most widely encountered by peace officers in assassinations. The bomb is generally found under the hood or dash compartment.
16. Aircraft.
17. Officials.
18. Embassies.
19. Churches.
20. Maximum security areas.

21. Schools.

205

22. Warehouse areas.
23. Public gathering areas—Bus depots, train stations, public lockers, subway areas, parks, etc.

### SOURCES OF SUPPLY

The sources of supply available to procure explosives and incendiaries are far too numerous to list, but the following are the most widely used.

1. Drug stores and warehouses.
2. Hardware stores—Ammonium nitrate fertilizers, etc.
3. Hobby shops—The modern hobby shops provide a multitude of supplies and should be closely checked for such supplies as:
  - a. Fuzing systems (electronic).
  - b. Incendiaries.
  - c. Chemicals.
  - d. Containers.
  - e. Mechanical timing devices.
  - f. Burning time fuse.
  - g. Carbide devices.
  - h. Transmitters and receiving units.
4. Construction sites (dynamite, detonators, etc.).
5. Military magazine areas.
6. Machine shops.
7. Battery shops.
8. Chemistry laboratories.
9. Paint stores.
10. Plumbing and heating stores.
11. Hospital supplies and hospitals.
12. Match makers.
13. 5c & 10c novelty stores.
14. Fireworks stands or sources.
15. Photography distributors.
16. Soap and candle makers.
17. Electronics dealers.
18. Acetylene and liquid oxygen dealers.
19. Fertilizer (oxidizer) dealers.

206

The above listing constitutes the majority of sources for the various oxidizers, chemicals, incendiaries, and explosives used in the manufacture of clandestine and sabotage devices.

### ANALYZING AND EVALUATING A BOMBING OR INCENDIARY PROBLEM

The problem of analyzing and evaluating a bombing or attempted bombing is a difficult one indeed. The perpetrator, in most cases, has the advantage of time when using a bomb or like device and, in addition, the element of confusion or panic when the device has initiated.

Needless to say, any area which is the target of threats, unexploded items, or actual bombings should immediately, or perhaps even prior to any incident, start actions to eventually net the bomber and discourage any future bombings or incidents. This can be accomplished by close liaison between the source of supply and the general target or target area of the bomber or firebug concerned. The preservation of evidence is very important in unexploded items because, with the materials, the area in which to establish close coordination can be pinpointed, due to the perpetrator's supplies. Following are some suggestions listed to perhaps use as guidelines in the event of an actual bombing incident.

**Conferences and Communication**

1. If the explosive or incendiary device is known, all supply distribution points and stores should be contacted by either conferences or written circulars to closely check any individual who appears for this type of material or chemical.
  2. Compile a list of institutions which may be a potential target and hold conferences with the responsible officials.
  3. Establish a system of reporting in the neighborhood or target area by alerting various responsible persons to note any unusual activity.
  4. Coordinate and intensify patrol of these critical areas and points of supply.
- 207
5. Exploit all previously known offenders.
  6. If the explosive or package is not known, contact all possible sources of supply to remain alert and to report immediately any suspicious person.
  7. If the explosive or device is military, contact the nearby military explosive ordnance disposal teams and military police for advice and assistance.
  8. Establish contact and close liaison with nearby law enforcement agencies to be alert for a possible lead.
  9. Establish plans for future incidents with all officials concerned. Well laid search plans, evacuation, and communication plans will avoid hysteria and excessive damage.
  10. Preservation of evidence, interviews, method of operation, and laboratory assistance is extremely valuable in any incident.

The preceding steps by no means cover the vast plans and detailed investigative procedures involved in a bombing or like device, but will serve as good steps, if followed, A sound, basic, condensed plan to use is:

1. Appoint one or more people within a department to set up and coordinate plans.
2. Establish a file for incidents.
3. Obtain equipment and/or assistance to combat incidents.
4. Affect liaison with all officials concerned.
5. Exploit all sources of supply.
6. Arrange for immediate assistance of explosives experts.
7. Offer rewards if necessary and conduct conferences.
8. Exploit any threat, and interview the parties concerned, no matter how insignificant.

**INCIDENT REPORT FORMS AND BOMB FILES**

Each department should maintain handy forms relative to each bomb incident to properly classify the data and to keep information for future incidents of the same nature. The following forms are samples of the type which a unit could maintain as a handy means of recording the data on any incident.

208

**Report Form - Front Side**

**INFORMATION FOR EXPLOSIVE BOMB FILE**

Reporting Office .....

Date .....

The factors shown below are used in classifying data received relative to explosive bombs. Unless otherwise indicated, a check mark will suffice in sections I and II.

- |   |  |
|---|--|
| <p><b>I. TYPE OF BOMB:</b></p> <p>A. Time .....</p> | <p><b>II. EXPLOSIVE:</b></p> <p>A. Low .....</p> |
|---|--|

- |   |   |
|---|---|
| <p>1. Mechanical (clock) .....</p> <p>2. Chemical .....</p> <p>3. Electrical .....</p> <p>B. Moneysnap (Press Key) .....</p> <p>C. Moving Parts (Metronome, Hinge of Hammer, sliding pins, etc.) .....</p> <p>D. Fuse or Lines .....</p> <p>E. Container .....</p> <p>F. Grenade .....</p> <p style="padding-left: 20px;">1. Military .....</p> <p style="padding-left: 20px;">2. Improvised .....</p> <p>G. Other (Describe) .....</p> | <p>1. Blasting Powder .....</p> <p>2. Pellet Powder .....</p> <p>3. Other .....</p> <p>B. High .....</p> <p>1. Dynamic .....</p> <p>2. Military .....</p> <p>3. Nitroglycerin .....</p> <p>4. Other (Explain) .....</p> |
|---|---|

**III. MODUS OPERANDI**

- A. Method, (postmark, place and date) .....
- B. Exposed, (shipping point, place and date) .....
- C. Planted on premises .....
- D. Planted in vehicle, (Type of vehicle and location of bomb) .....
- E. Thrown .....
- F. Other .....
- Other desirable information
1. Date, time, and place bomb discovered or explosion occurred .....
2. Law enforcement agency investigating and officer concerned .....
3. Weight of complete bomb .....
- 209

**Report Form - Rear Side**

(Desirable information continued)

4. Weight or amount of explosive .....
5. Dimensions of bomb .....
6. Manufacturer of explosive .....
7. Manufacturer of other components (Timers, etc.) .....
8. Type of detonator and manufacturer .....
9. If incendiary what type .....
10. Were Anti-Withdrawal or Booby Trap features present, explain .....
11. Successful method of Rendering Safe Procedure or deactivation .....
12. Suspected or known perpetrator (Name, Address, description):  
In custody .....
13. Victim or intended victim .....
14. Motive or intended motive .....
15. Method of disposal and date of disposal .....

APPROVED: Report made by:

- Enclosures
- Number
- ..... Photographs of bomb
- ..... Photographs of evidence (writing on tape)
- ..... Photographs of scene or explosion
- ..... Scientific drawing of writing or device
- Other .....

210

**Hasty Report Form, Simplified**

Another form, more simplified, and often used by Military EOD units is the one shown as follows:

**BOMB DISPOSAL REPORT FORM**

FROM: \_\_\_\_\_ TO: \_\_\_\_\_

1. INCIDENT				
Reported By:	Date:	Time:	Brief description by reporting person or agency:	
2. IDENTIFICATION				
Quantity of explosives or incendiary material:	Nationality:	Type Bomb:	Other:	
3. DESCRIPTION				
Weight (total):	Length:	Diameter:	Marks:	Color:
4. FUZING				
Mechanical:	Electrical:	Chemical:	Other:	
5. Rendering Safe Procedure (explain) use reverse side if necessary				
6. Disposition of Item:				
7. Damage or injuries to personnel or material:				
8. Remarks:				
9. Attachments (photos, evidence, etc.):		Date:	Signature:	

241

### Chapter XI

## APPROACHES TO RENDERING SAFE AND NEUTRALIZATION PROCEDURES

THE following procedures are a general outline to be used as a guide in your approaches to, and neutralization of, clandestine and improvised sabotage devices. There are no hard set rules or foolproof methods that can be used on suspected packages. Therefore, each situation will vary per incident as the construction of the bomb is limited only to the ingenuity of the perpetrator.

The phases outlined in this section closely parallel the battle plans of a military combat situation. They set plans and, in any moving situation, it is essential to have plans that can be put into operation immediately upon receipt of a call or actual bomb incident.

If a bomb threat or actual explosive device is being employed, you are in fact engaged in a type of war and no battle was ever won without a pre-set calculated plan of attack. I believe an old military phrase reads that "The best defense is a well-planned offense."

There are, however, hard and set rules within the actual "contact" phase of these procedures which must be observed to preserve the life and limb of the disposal experts.

Experts tend to be vain and heroic and feel that there are no devices which they cannot render safe and ego, therefore, leads them to believe they are infallible.

This statement is far from true because a well-educated elec-

212

tronics technician can construct devices which are impossible to render safe and we should bear in mind that, no matter how serious the situation is, we can always replace or rebuild a building but we cannot replace a man!

Current sabotage books explain the many devices that may utilize a sensitive vibratory, proximity, or like device as a protective means of switching or triggering certain bombs if they are disturbed. Therefore, we must do everything within our power to attempt a rendering safe procedure by remote means.

In most cases, a clandestine device will be small in nature and, if proper baffling and buttressing procedures are followed, the blast effects can be minimized should an explosion occur. We can do everything within our scope to render safe a device, but certain devices are designed to fire and *cannot* be rendered safe once they are armed.

We can effectively combat about 90 per cent of the devices and perform a rendering safe procedure with a minimum risk to life if we follow the hard set rules during physical contact with the device.

A recent case, as an object lesson, involved a disposal expert whose technique was to reach in and cut wires separately; thereby isolating the electric circuits. The personnel with whom this man was engaged were not psychotics or amateurs, they were highly trained terrorists with a very technical background in fuzing and firing systems as applied to ordnance. The expert rendered safe a number of devices by cutting wires and isolating the power sources but, on the next incident, the wire he cut collapsed the electric field and very suddenly ended his career in disposal.

This courageous man cannot be downgraded for his efforts, as we all know it takes fortitude to attack a live bomb by hand. However, his misfortune should serve as evidence that we can, in many cases, do the same job by remote means.

The British, during World War II, learned that certain devices would explode at a certain step during the rendering safe procedure and usually personnel were lost during this step. A human life was sacrificed to learn that a bomb would detonate if certain procedures were followed. This seems to be a very high

245

price to pay for learning the operation of a fuze designed to function when it is tampered with.

If we cannot render safe the fuze, or if there is any reasonable doubt, we might as well clear the area, place a charge along side, and detonate the device; destroying the building and surrounding area, but without the loss of one human being. If certain rules set forth in this plan of attack are observed, our risk can be minimized and we may accomplish the mission of a "rendering safe procedure (RSP)" with a maximum degree of safety to the public and ourselves.

### EXPLOSIVE INCIDENT CATEGORIES (PRIORITY OF ATTACK)

Each incident involving a bomb should be assigned a priority or category number and should be coded within the department to indicate the nature of a bomb or life device. The category of the bomb can be determined by answering the following questions:

1. Must the bomb be rendered safe and should it be worked on immediately?
2. Can the bomb be detonated in place or "situ"?

To assign a proper category number, we must first know the general size of the bomb, its destructive power, its location, and whom it will effect. The general categories within this section are flexible as certain departments may assign a high priority to certain bombs where evidence is required to gain information about the perpetrator.

### CATEGORIES

The following descriptive categories will serve as guidelines for assigning code numbers to certain incidents within any department.



1. **Category A-A-A**—The highest priority and involves a situation where the general population would be evacuated to a great distance and the maximum effort placed in effect. An example of a category A-A-A would be a suspected nuclear device

214

or a bomb of such size and destructive force that it would destroy a large area or vital installation, activated by a time delay fuse. This situation would call for immediate action and maximum effort between military, civil units, and the general population. A preset plan for this category is essential.

2. **Category A-1**—The bomb should not explode and should be attacked without delay. If proper evacuation is effected, the bomb, should it detonate, would not injure or kill personnel. The category is of a high priority because of the loss of valuable property. The size of the bomb in this category would also dictate the A-1 priority.

3. **Category A-2**—The bomb must be disposed of without delay but is located in an area where it can be detonated in place without endangering disposal personnel. An example of this category would be a bomb in a postbox located in an open area.

4. **Category B**—Time is not vital and detonation of the bomb would not destroy valuable property or endanger lives. If a delay mechanism is involved, the bomb squad may wait out the expected delay time plus a 50 per cent safety factor.

5. **Category Z**—This category is assigned to a bomb where recovery of the item is important for evidence or research. This category would be closely associated with category A-1, but no undue risk should be placed upon the disposal personnel. An example of this category would be a psychotic bomber who repeats and whose method of operation is important for detection.

#### APPROACH AND RENDERING SAFE PHASES

For purposes of good organization, the approaches and actual attacks on suspected packages have been broken down into phases with procedures to follow in each phase. It would greatly increase efficiency if handy check sheets using the phase system were available to commence a set plan from the receipt of a call or actual incident report.

The phases generally are:

1. Immediate action phase.
2. Approach phase.

215

3. Contact phase.
4. Access and RSP phase.
5. Transport phase.
6. All clear phase.
7. Disposal area phase.

One important factor to remember in any disposal operation is to work as a team, *never work alone!* A minimum of two men should be present for any incident.

#### PHASES DETAILED

1. **Immediate action phase**—Consists of the actions taken upon receipt of a call or actual incident report. It would be wise to use check sheets where possible. This phase consists of measures such as:

- a. **Information:** Obtain as much information as possible concerning the item: such as size, exact location, etc. and it may be placed temporarily into a category at this time.
- b. **Notification of authorities:** Medical, fire, unit assistance, military bomb disposal should be notified promptly.

c. **Evacuation procedures:** If deemed necessary, evacuation procedures could start by phone messages. In any event, it is essential to have a good evacuation plan and civil defense or other units can assist by using a pre-arranged plan.

d. **Area guard and safety:** Along with evacuation, the area guard and safety measures can commence: such as cutting off power supply, gas mains, and roping off or blocking the area.

2. **Approach phase**—Consists of measures taken en route to the incident and upon arrival at the scene. Important steps would be:

a. **Area survey:** En route to the incident, check maps and visually survey the general route of travel for vacant lots, open area, routes of escape with the bomb, and the best route to the disposal area.

b. **Approach:** One or two-man approach to the item to establish a tool and equipment standby within communication

216

range. Set up hasty communications (no radio transmissions) and carry a light tool kit to the bomb area. Discard any nylon clothing or metallic objects and wear armor protective clothing, if available. Insure that fire or police vehicles do not transmit in the near vicinity with radio equipment.

c. **Hasty survey and evaluation:** On the scene, quickly evaluate the item as to type, size, possible initiating actions, amount of explosive, etc. Do not touch the package at this stage and, if possible, evaluate at a distance. Evaluate quickly what tools are necessary to do the job and the possible damage should the bomb detonate.

d. **Baffle, buttress and protective steps:** Open near windows, baffle with mattresses or available material, clear area of combustible materials: being careful not to jar the item. At this stage, insure that fire equipment is located nearby. Certain portions of these measures can be performed by personnel assisting in the operations.

3. **Contact phase (most important)**—This phase is often termed the "go or no go" phase and involves actual contact with the device: but before any contact is made these steps should be followed:

a. **Jar and tumble remotely:** This must be done first to preclude the use of sensitive vibratory or mercury switch and, while rigging the apparatus necessary, no physical contact to the package should occur. This step can be accomplished by use of a grapple hook, fish hook, shotgun, or even a long pole and the package should be turned over in two different directions with the operator being at a safe distance.

4. **Access and RSP phase**—Once the package has been jarred and tumbled, a number of variable attacks could be employed, depending on the disposal expert in charge. These steps will be discussed in detail, however. In certain situations, the expert may determine to:

- a. Listen, using an electronic, regular, or improvised stethoscope to determine a clock delay present.
- b. X-ray or fluoroscope with portable equipment.
- c. Drag away with a long rope to an open area nearby for RSP.

217

- d. Blow in place.
- e. Transport immediately in Bomb Carrier.
- f. Wait out—144 hours plus 50 per cent.
- g. Gain access remotely and look.
- h. Take apart remotely.

## Remote Methods of Access or Direct Attack

1) **Shotgun de-armor:** This method was designed and exploited by the author as a means to gain access to suspected packages remotely; to destroy, or merely puncture and look into suspected devices. The equipment needed for this operation is readily available and requires a 12 gauge shotgun or riot gun, a fishing reel, 2 sand bags, and assorted shotgun cartridges "00", No. 8, etc. The entire rig requires about three minutes to assemble and tests indicate that it will remotely open the strongest of package materials (suitcases, pipes, boxes, etc.). The attacks with this device varied from shooting holes for observation to direct attacks into the mechanisms and were successful in about 90 per cent of the tests.

In most cases, if the shotgun is aimed at the junction of certain boxes and suitcases, the shot will miss the main explosive charges but will successfully open the box. The setup consists of using either rifled slugs, "00" buck shot, or No. 8 chill shot. Stand-off distances from the muzzle of the shotgun varied from twelve inches to three feet.

To set up the shotgun de-armor, a bridle was rigged (using the fishing reel with strong fishing line) to the trigger of the shotgun and one sandbag was placed down. The shotgun was placed loaded on the sandbag, aimed at the package, and another sandbag was placed on top of the shotgun to compensate for the recoil.

The operator then reeled out the fishing line to a safe distance and fired the shotgun with amazing results. The following illustrations demonstrate the results of the shotgun method in opening or destroying certain packages. Due to the low velocity of a shotgun cartridge, it can be fired in most public areas if evacuation has been carried out.

218

The prime aspect of the shotgun de-armor is to gain access to a package remotely by missing the main charge. However, in one case the author fired directly into a clock mechanism and batteries completely destroying the mechanisms. The batteries were tested and found to be completely destroyed due to separation of the plates and terminals.

Many questions were asked during these tests about bullet sensitive explosives. However, it was found that certain materials could be placed between the shotgun and the item; such as a wooden board to reduce the velocity; and no detonation would occur from the shock of the pellets striking the main charge. In

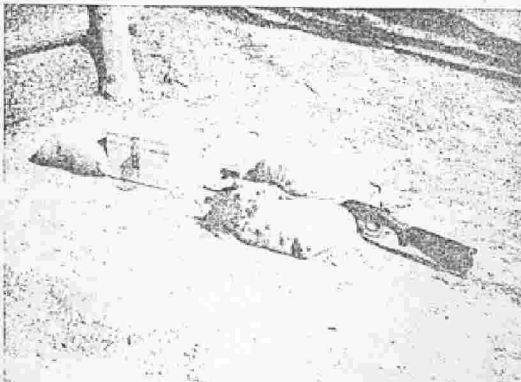

FIGURE 149. Shotgun de-armor in position for attack on suspected package. Stand-off distance, approximately twelve inches.

219

one instance, a blasting cap was ripped apart without detonating the charge. Each bomb squad should assemble various packages and run tests with the shotgun, using various materials and cartridges to determine the capabilities of this remote tool. It has proven to date to be one of the remote means of attack and access which is superior and safer than any hand attack. The following photos will best indicate the author's results in his experiments with the shotgun.

220

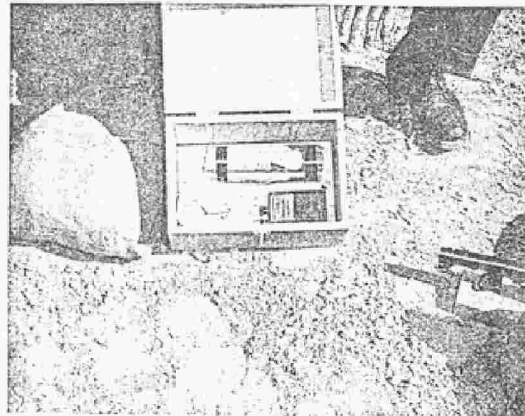

FIGURE 150. Clock delay device shown prior to attack with shotgun de-armor

221



FIGURE 151. Shotgun de-armor aimed at hinge and hasp section of suspected package. Twelve inches stand-off.

222



FIGURE 152. Box after shot. Note hinge and lisp ripped apart and lid raised open.

223

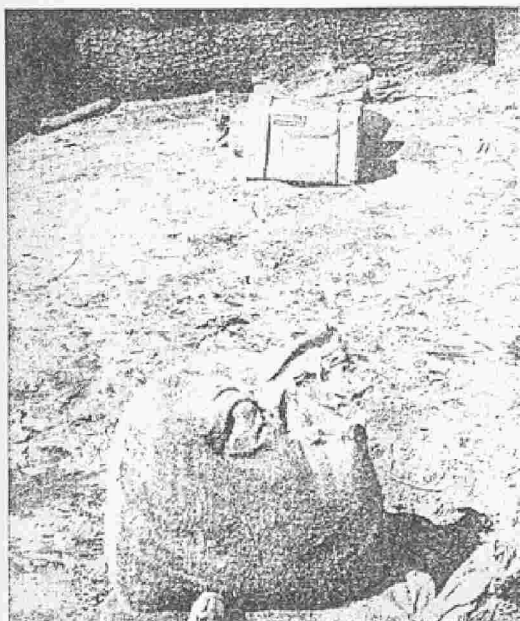

FIGURE 153. Slungun de-ammor in position for direct shot on suspected package. Stand off distance, six feet.

224



FIGURE 154. Access hole after de-ammor shot.

225

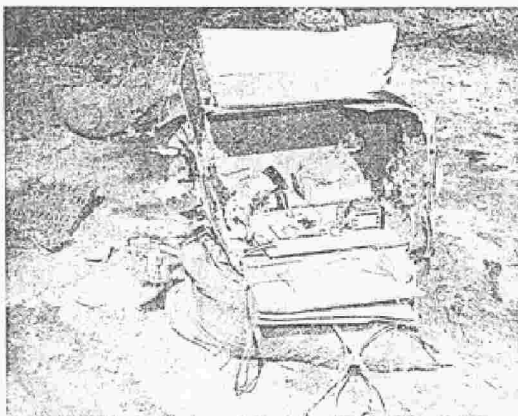

FIGURE 155. Clandestine package after direct attack with slungun de-ammor. Four shots of No. 8 chill bird shot.

226

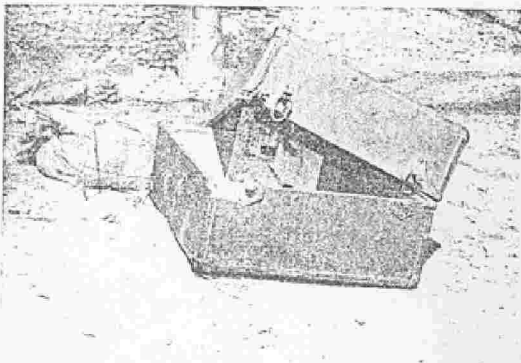

FIGURE 156. Suspected package after slungun attack on hinged corner. Lid ripped open.

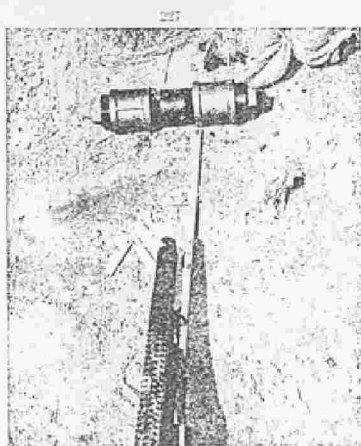

FIGURE 157. Shotgun clewmer in position for attack on pipe bomb. Twelve inches stand-off. No. 00 buck shot.



FIGURE 158. Pipe bomb after shot. Vent hole opened in center of pipe.

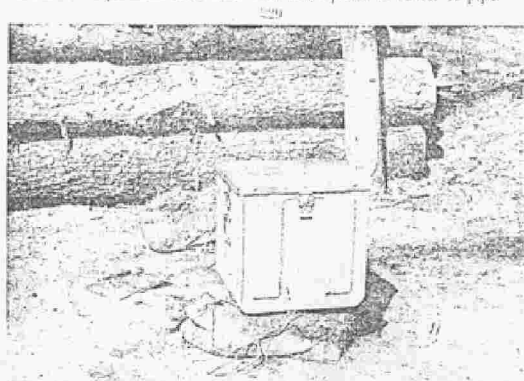

FIGURE 159. Heavy steel box positioned for access attack with shotgun clewmer. No. 00 buck shot used on hinges.

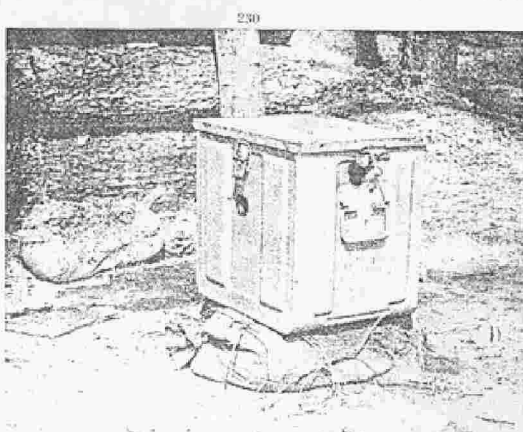

FIGURE 160. Hinge area on steel box opened by shot. Hole on side of box opened with shotgun rifle slug.

2) **Tri-tong method:** The system of ripping packages apart by remote means was designed by the New York City Bomb Squad. It consists basically of two pairs of ice tongs with an attached rope about 150 feet long. The tongs are attached to the package (suitcase, etc.) and two operators at a distance rip the package apart by pulling vigorously. Figure 161 best illustrates this method.

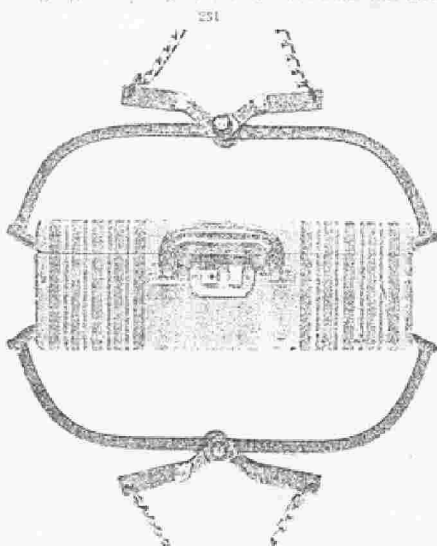

FIGURE 161. Tri-tong method of ripping open suspected package.

3) **Grapple hook method:** Used basically the same as the tri-tong method. Grapples may also be used to drag the packages away from the scene by remote means.

4) **Burning technique:** In many cases, a suspected package may be burned and, contrary to opinion, the main charge may burn completely before the detonator explodes. The package may be ignited by means of fuel, thermite grenades, or other

flammables. In all cases, the package should be well vented in several places as confinement plus heat will cause the explosive to detonate. This system is not foolproof and one should always stand by for an explosion but, in certain cases, it does work.

232

5) **Blast apart:** Small explosive charges may be placed near the package by means of a long pole or rod. The small charge is then exploded to rip the package apart by blast effect. The small explosive charge should not be married to the actual package and again one should stand by for a sympathetic detonation when using this system.

6) **Shape charge method:** Cavity containers (shape charges) in certain instances may be employed in open areas against pipes and tight containers. This will serve to vent and, in certain cases, burn out the explosive charges.

### Rendering Safe Procedure (RSP)

Once access has been gained to any suspected package by remote means there are certain procedures which will take a natural course in the rendering safe procedures of various devices. These procedures will vary due to the unlimited amount of devices encountered, but generally speaking, they are:

1) **GAG techniques:** Applied to movable plungers, clocks, etc. and consist of any measure taken to prevent movement of a mechanical device. One method is by use of plaster of Paris and water. Others are by sugar, water solutions, syrup, or thick oil to stop clocks.

2) **Separation techniques:** Separation of chemicals, detonators from main charges, and electrical separation are considered to be separation techniques. All electric circuits should be thoroughly traced before cutting any wire, due to the possibility of a collapsing circuit. When performing an electrical safing procedure (ESP), always cut and tape only one wire at a time and beware of a flexible strand contained in what may appear to be a single strand insulator. Separation of detonators from main charges should be done remotely due to internal booby traps in manufactured sabotage items.

### 3) Replacing safety devices or pins:

4) **Freezing procedures:** The use of CO<sub>2</sub> plus alcohol, liquid nitrogen, or other freezing materials may be applied or injected into certain devices to lower the firing potential of certain batteries in an electric circuit. One should bear in mind that, once

233

freezing is started, the batteries must be kept frozen. Otherwise, the firing potential will rise as the temperature rises.

5) **Submerging techniques:** Consists of puncturing the package and submerging in oil to stop clocks or to saturate various explosive and chemical mixtures.

6) **Trepanning:** The use of strong nitric acids to corrosively eat a small hole into metallic containers by means of a fine acid spray directed against the container.

7) **Steaming:** Once access is gained on certain high explosive devices, steam directed at the explosive will melt the explosive into a water-like mass. This technique should always be done remotely and once steaming is started, do not stop until it is completed. Never stop steaming and return later to commence re-steaming as detonation is likely to occur.

8) **Transportation phase—**This phase may have taken place during the contact phase if certain equipment (bomb trucks, special carriers, etc.) were available. In any case, there are certain rules to follow while transporting any live items. These rules will depend on the item before or after the rendering safe procedure, and the general size of the item. Certain general rules are:

- a. Provide escort, if necessary.
- b. Use placards (explosive signs).
- c. Equip truck with sand bags, loose sand, and damage.
- d. Keep listening—if devices are transported intact. Clock-work could be activated.
- e. Have police search site area for additional devices.
- f. Communications enroute to disposal area.
- g. Shut electric blasting caps prior to transporting, or electric squibs, etc.
- h. Take routes that are least congested, based on map of city.
- i. Freezing enroute may be desired in cases.

9) **All clear phase—**Once the device is located in a safe disposal area, notify the proper officials at the scene and local areas so that evacuation and other disrupting procedures may cease.

10) **Disposal area phase—**This phase is almost self-explanatory. However, there are many hazards to observe in this phase due to

234

the nature of crude or improvised explosive and chemical devices. In many cases, extra dangers may be presented in an effort to preserve samples for evidence. Some precautions and hazards encountered in the disposal area are:

- a. Acids.
- b. Hypergolic (violent) reactions.
- c. Black powder in threads or loose black powder in friction-moving components.
- d. Photo-flash powder.
- e. Incompatible items.
- f. Extraneous electricity.
- g. Disposal area control.
- h. Impure nitroglycerin.
- i. Directional munitions.
- j. Cocked strikers.
- k. Toxic gas.
- l. Powdered high explosives (most dangerous).

### COMMON AND SPECIAL TOOLS

The following tools are some which are carried by bomb squads and will serve in most cases to render safe a large majority of suspected packages.

#### Common Tools

1. Glass knife—locally made by a glassmaker (non-conductive).
  2. Glass probes.
  3. Razor blades.
  4. Medical stethoscope.
  5. Beer can opener and can opener.
  6. Rifle bore-scope.
  7. Flexible mirror.
  8. Surgeon's knife with blades.
  9. Pipe vise; portable large jaw type.
  10. Flex tube flashlight and pen lights.
  11. 500 feet of strong, light flexible cord (nylon).
  12. Paper clips and assorted cotter pins.
  13. Dental mirror.
- 235
14. Fibre hacksaw blades and hacksaw.
  15. Tongue depressors (wood).
  16. Foam rubber matting (sheets).
  17. Sand bags.
  18. Mattresses (4).
  19. Plaster of Paris and five gallon water can.
  20. Ice tows with 200 feet of cord each.

21. Plastic containers.
22. CO<sub>2</sub> fire extinguishers (5).
23. Methyl alcohol (5 gallon).
24. Rubber gloves (surgeon's).
25. Two five gallon cans of light oil.
26. Safety glasses.
27. Tape: electrical or friction.
28. Grapple hooks and treble fishing hooks: large size.
29. Communication equipment: portable field phones, etc.
30. Shotgun with assorted cartridges.
31. Fishing reel with cutyhunk line.
32. Area maps.
33. Blasting equipment.
34. Explosives for detonating in place.
35. Incendiary grenades.
36. Cavity containers.
37. Bolt cutters.
38. Self contained oxygen breathing apparatus.
39. Gas masks and impermeable clothes.
40. Assort common tools, wrenches.
41. Armored clothing—vests, masks, etc. (See chapter 13).

#### Special Tools

1. X-ray unit (See chapter 13).
2. Bomb carriers (See chapter 13).
3. Power entry equipment: abrasive wheels, saws, etc.
4. Portable generators.
5. Hoists, chain falls, etc.
6. Camera equipment (polaroids, etc.).
7. Public address systems.
8. Explosive identification kits.

236

9. Radiac instruments.
10. Metal detectors: snaf finders.
11. Nitroglycerin destroyer kits.
12. Trepanning and steaming units.
13. Remote wrenches.
14. Pneumatic spades, jackhammers, etc.
15. Electronic stethoscope and tape recorder unit.
16. Freezing kits.

237

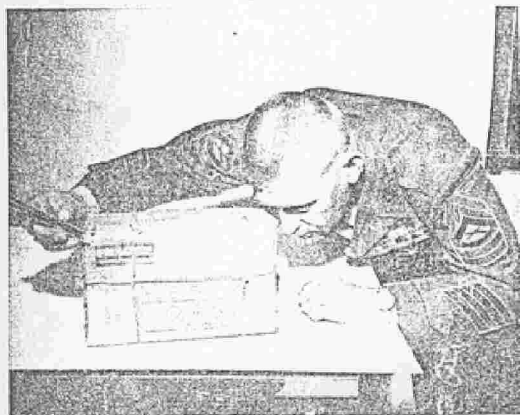

FIGURE 102. Bomb disposal expert examining contents of suspected package.

The illustration shows the technician examining the contents of a suspected package after use of the special and common tools.

The corners of the package have been carefully cut away using a glass knife, and the contents are being observed by peering into one corner while using a pen light in the opposite corner. This method is not recommended unless it is a last resort, as the fuzing system could employ a long delay fuse which could explode the device at any time. Remote means of access are preferred where possible.

238

#### Chapter XII

### SAFETY DISTANCES AND EVACUATION PROCEDURES

IT is extremely difficult to set down a ruling as to exact fragmentation distances and blast damages based on the size or estimated weight of a package. Certain directional munitions throw high speed fragments, base plates, etc., for distances as great as 2400 yards; far beyond the normal expected or ballistic data ranges. There are many problems, too, encountered with just plain evacuation in a metropolitan area, as you can well imagine.

Control is difficult to maintain over curious onlookers, TV, press, etc. in a moving situation.

It is a good practice, depending on your location, to set up well in advance and coordinate with local civil officials various types of codes and plans for any explosive ordnance incident such as:

1. Search plans— for anonymous phone calls, bomb scares, etc.
2. Control and evacuation plans.
3. Area safety plans— gas, water, light, medical, etc.
4. Plans for certain individual cases (suicidal, psychotics using explosives, etc.).
5. Classes for local officers, civil defense units, firemen, etc. (recreates good will and makes for good cooperation).
6. Maintain liaison between adjacent city, military explosive ordnance disposal, and civil peace officers.
7. Pre-arranged intercommunications setup.

239

#### EVACUATION

Many bomb scare reports will be received by law enforcement agencies by telephone, letter, or brief notes. Each and every one must be treated as legitimate until it is thoroughly checked out. This requires the utmost in pre-planning among all city departments concerned and the employment immediately of every force in readiness for a bomb scare or an actual incident.

Panic must be avoided at all costs and the area proper must be evacuated to make room for the bomb experts, doctors, and other key personnel.

It is probably best for the general public to be evacuated from the scene without actually knowing the reason until the threat has passed.

It is wise to organize certain trained individuals for search groups, prior to a bomb incident. A volunteer rescue squad with general background training in the identification of a suspected bomb or package can give valuable assistance at the scene. Once a call is received, there are certain general steps to be carried out as follows:

1. Clear the danger area of all occupants and especially curious bystanders.
2. Obtain the services of an explosive ordnance disposal expert, military or civilian or both.
3. Search parties avoid moving or jarring any object.

4. Establish an area guard.
5. Shut off gas, power, and fuel lines in the danger area.
6. Remove flammables from the danger area.
7. Notify the local fire departments and rescue squads.
8. Arrange for medical aid on stand-by.
9. Obtain mattresses, sandbags, or other baffle devices.
10. Set up good communications and control equipment at the scene.

Once the above general procedures have been effected, the actual search can proceed. These steps are outlined in detail after the section pertaining to safety distances, formulas, and damage tables. The safety distances and damage tables will serve

240

as a good general guide for area evacuation if the size of the package is known. If not, the search will turn up developments where the tables may or may not be utilized.

**SAFETY DISTANCES AND FORMULAE**

(for Fragmentation or Shrapnel Munitions)

1. One formula used for figuring safety distances in feet is=  
 $D = 600 \times \sqrt[3]{\text{explosive weight in pounds}} = \text{safe distance in feet. Example: Estimated weight of the explosive device is ten pounds of explosive having a fragmentation capability.}$   
 $D = 600 \times \sqrt[3]{10} = ?$   
 $D = 600 \times \text{cube root of } 10 = ?$   
 $D = 600 \times 2.1544 = 1,292 \text{ feet of safe distance.}$

The above formula is good for figuring large items. However, the majority of suspected packages will be below five pounds and we must resort to some degree to experience and practical application. 1,000 yards for the largest munition is sufficient for fragmentation hazards, in most cases.

2. Most small munitions (below 5 lbs.) in the military have effective ranges up to approximately 150 yards. This figures out to about 450 feet, based on the distance of effective fragments. A good rule of thumb would be to figure about 150 yards evacuation outdoors in open areas for items up to 5 lbs. in explosive weight capable of throwing fragments. For items capable of throwing fragments or shrapnel above five pounds and up to twenty pounds, one should double the distance to 300 yards in the open. Items beyond twenty pounds in explosive weight should be figured by using the formula

$D = 600 \times \sqrt[3]{\text{explosive weight in pounds}} = \text{Safe distance}$   
 These, of course, are only rule of thumb measures. Much will depend on the situation at hand. For instance, a small device less than five pounds in weight located in a building of brick structure would not require the whole city block to be evacuated. In these cases, just localizing the building

241

proper would be sufficient if an rendering safe procedure were to be performed on the spot. However, if the item is moved to an adjacent open area, bystands must be placed out of the fragmentation range.

**Blast Distances**

The table below is useful in figuring blast and debris safe distances for bulk explosives. Of course, measures must be taken during the approach phase to minimize this type of damage should a detonation occur.

**Safe Distance Formula**

Personnel in the open are safe from missiles created by bare

changes in or on the ground, regardless of type or condition of the soil when the following formula or table is used. Safe distance in feet =  $300 \times \sqrt[3]{\text{pounds of explosive}}$ .

**BULK EXPLOSIVE SAFE DISTANCE CHART**

Pounds of Explosive	Safe Distance in Feet
1-25	910
29	950
32	950
36	1000
40	1029
44	1050
48	1090
50	1100
55	1140
60	1170
65	1200
75	1265
80	1290
90	1345
100	1380
125	1500
150	1590
200	1750
300	2000
400	2210
500	2385
Over 500	2400

NOTE: Minimum distance for personnel in missile proof shelter is 500 feet.

-242-

It is often been said that one-half pound of TNT placed three feet away from a human being is sufficient to be lethal from the blast effect. These situations vary, however. In one instance, three pounds of dynamite killed four people in a school yard in a circle about eight yards in diameter. A directional blast wave often occurs, even with blast types of munitions.

I have thoroughly researched the majority of military ballistic data manuals pertaining to fragmentation, blast, and shock damage; and it is difficult to say exactly in feet and yards just how far to evacuate personnel to place them completely out of danger from flying fragments.

The majority of military ballistic manuals states how many casualties will occur in a certain radius, or maximum effective ranges; but very seldom states just how far the fragment will travel before it stops.

Most disposal teams know by daily experience in range sweeps about how far to move away from a large demolition shot, but even then we are sometimes fooled by certain unpredictable fragments.

It is not practical in large cities or incorporated areas to evacuate entire city blocks and, in some cases, it would be impossible anyway.

It will be up to the individual technician in charge of the incident to determine just how far to evacuate personnel from the scene; based on the size of the item and type of item. We can only utilize the formulae and experience of field trained men as each case will be different. *Common sense in most cases is the best formula.*

243

**Fragmentation Type Bombs**

**DAMAGE TABLE**

CONDITION: This table is figured on bombs in the open near exposed and fragile structures. The explosives are considered to be high explosives so if low explosives are used, these figures can be reduced accordingly.



Bomb Explosive Weight	Destructive Radius	Irreparable Damage	Repairable Damage	Minor Damage	Minimum Safe Distance From Fragments in the Open
1-40 Pounds	5-5 Feet	5-9 Feet	25 Feet	100 Feet	800 Feet
10-25 Pounds	6-10 Feet	10-15 Feet	30 Feet	150 Feet	1700 Feet
50 Pounds	12 Feet	23 Feet	50 Feet	300 Feet	2100 Feet
150 Pounds	19 Feet	36 Feet	100 Feet	650 Feet	3180 Feet
250 Pounds	30 Feet	60 Feet	150 Feet	800 Feet	5720 Feet
500 Pounds	47 Feet	95 Feet	190 Feet	1120 Feet	7900 Feet
1000 Pounds	75 Feet	150 Feet	300 Feet	1600 Feet	13800 Feet

NOTE: The chart above is given to be used as a guide only and is based on ballistic data and field experience. If there is any doubt on an item, increase the distances slightly for reasons of safety.

#### DETAILED SEARCH PROCEDURE AND PROTECTIVE WORKS

There is no foolproof or positive plan to handle all incidents, because of the location and types of devices employed but the following plans may be used as guide lines. Evacuation in any case should begin the minute a call is received to prevent unnecessary loss of life. From receipt of a call of a suspected bomb or like device, the following procedures may be used:

##### First Evidence

1. **Phone calls**—Notes or recordings should be taken on exact language used, accent, sex, background noises, time, and place of bomb or package.

243

2. **Evacuation.**

3. **Letters**—Photograph if possible, and note details of handwriting, type of paper, etc.

##### Search Procedure

This phase is most important and, for purposes of control, certain individuals and groups must be detailed to perform the actual searching. Certain information should be given to the search party such as:

1. Exact words given as to the location and expected time of the explosion.
2. Times to halt or continue search.
3. Floor plan of search area, if available.
4. Search Plan; simplified, as complex plan may result in poor coordination.
5. Communication plan.
6. Location of medical aid standby.
7. Possible pattern or method used by previous bombings of incidents.
8. Exact location of explosive experts stand-by group.

##### Likely Places or Areas for Suspected Devices

1. Lockers.
2. Behind pictures or clocks.
3. Under loose boards.
4. Observe fresh paint or plaster.
5. In toilet tank reservoirs.
6. Behind and under sinks and plumbing (often suspended).
7. Inside couches and hollow furniture.
8. Basement areas.
9. Potted plants (disturbed dirt).
10. Under stair wells.

11. Inside stoves, refrigerators, and cabinet areas.
12. Waste baskets and disposal cans.
13. Inside television and radio cabinets.
14. Automobiles (all compartments and concealed areas).
15. Closets.
16. Air conditioning or heating vents and flues.
17. Inside hollow base lamps.

245

##### Protective Works

Once it has been determined that an explosive item or suspected package exists, we can start protective works utilizing the minimum number of personnel to affect these measures for reasons of safety.

1. **Venting**—Consists of opening windows, doors, etc., to minimize blast damage.
2. **Buttressing**—Normally not used with small devices, but consists of sandbagging adjacent walls to prevent blast and shock damage.
3. **Baffling procedures**—Mattresses or other materials placed around the package to minimize blast and fragment damage.
4. **Taping**—Near area building windows may be taped or covered with tarps to prevent blast damage and breakage.

If the bomb is located in a building basement area and contains over twenty-five pounds of explosive, areas up to 150 feet around may be damaged by card shock and additional measures of trenching, buttressing, and barricading may be necessary to minimize the damage, should an explosion occur. Finding a bomb or like device with an explosive weight over twenty-five pounds is quite unlikely but not impossible, as a bomb recently was found near Fort Sill, Oklahoma, with a damage capacity of one fourth of a mile. If a bomb of this size were to detonate in a basement section of a building below ground level, it would cause great damage to nearby gas mains, water pipes, and nearby building foundations unless proper measures of trenching, etc. were taken. Most nearby military explosive ordnance disposal experts can advise on proper protective measures to be taken if an extremely large explosive item is located and appears too dangerous to move.

246

##### Chapter XIII

#### ORGANIZATION OF THE BOMB SQUAD

THE size of a unit, population of the city, and frequency of incidents will dictate the number of personnel to assign to an organized bomb squad. There is always a possibility of a bombing or like incident regardless of the community size. Therefore, an organization should be created within any peace officer unit and certain levels of training maintained.

Each and every peace officer in the United States should at least familiarize himself with the contents of this book to better assist or perform on an incident should his services be required.

Certain principles or ground rules based on experience are necessary to any good organization of bomb disposal and these are:

1. **Teamwork**—On any incident, no one man should work alone. Always work as a team in the event an accident occurs.
2. **Reserve Stand By and Assistance**—In any moving situation, it is essential to have a trained reserve element for support and assistance where needed. This may also include duties such as recording certain data and maintaining communications.

The above statements and principles indicate that a truly efficient bomb organization would require a minimum of three people, well trained in their mission.

#### MEMBERS OF THE SQUAD

Applicants for this type of duty should have prior civilian or military training; however, it is not mandatory if they are properly trained at the unit level. It would not be considered a good practice to commit a peace officer to demolition or bomb disposal duty without actual field demolition experience, due to the risk involved.

New York City for instance utilizes highly trained detectives operable on a 24-hour basis for the handling, rendering safe, and disposal of all suspicious packages, and for investigation of explosions. Members assigned this duty should be closely evaluated as to I.Q., temperamental suitability, aptitude, and background.

#### ORGANIZATION AND STANDARD OPERATING PROCEDURES

An organization chart and standard operating procedure pamphlet should be prepared and made available to all members of the department and to any outside units who may be called upon to assist on any incident. A sample organization chart would place emphasis on certain units or individuals for control (Figure 163).

#### SAMPLE ORGANIZATION CHART

PUBLIC SAFETY  
DEPT.  
METROPOLITAN POLICE  
CHIEF  
Bomb Signal Officer  
Training Officer  
Public Information Officer  
Area Control Officer  
Team or Teams  
Communications Officer  
Medical Officer  
Vehicles and Tools Maintenance Officer  
Laboratory and Research Section  
Historians and Librarian  
Reserve Squads or Assistance Units  
Military Bomb Disposal Units.  
FIGURE 163.

#### TRAINING

A training officer and proper training area are necessary to any efficient bomb disposal squad as field work must be performed periodically to maintain a high degree of efficiency. Special emphasis is placed on the following:

1. Proper training and disposal areas.
2. Cross training.
3. Reference library.
4. Training aids and periodic problems.
5. Actual demolition work.
6. Frequent meetings (adjacent units, etc.)
7. Military co-ordination.

#### PUBLIC INFORMATION AND PRESS RELEASES

This is a delicate subject and, although the public should be informed, great care should be exercised; based on past experience, unnecessary panic can arise from over publicizing an incident.

In certain instances it is desirable to release the method of operation and sources of supply of a known terrorist to gain public assistance and information. The media of press in this respect can be used to put the citizen on his guard and will stimulate his observation towards the bombers operational areas. Certain shop keepers can be alerted by the press to be watchful for any persons who purchase large quantities of ingredients used to construct explosive devices—example: gunpowders, etc.

#### EVIDENCE AND PRESERVATION OF EVIDENCE

This phase is extremely important whether the explosion has taken place or not. Nothing should be rejected because it appears too big, too small, or insignificant. The investigation of an explosion or explosive device will naturally deviate to some degree from other forms of evidence. Listed herein are some procedures to perform during investigation of a safe package or an explosion incident. All physical evidence must be connected to the crime scene through photography, sketches, and written descriptions.

The "chain of custody" must be maintained until it is presented in court. Interrogation of witnesses after an incident or explosion is very important.

#### Physical Evidence

1. Extent of damage.
2. Seat of the explosion—This evidence may very well determine the type of explosive used such as high (shattering) or low explosive (pushing and cattering).
3. Fragments—Metallic, paper, wire, fuse, and debris found in the seat of explosion or crater may yield valuable information as to the device used.
4. Photographs and accurate scale drawings.
5. Time of explosion or incident call.
6. Interrogation of witness.
7. Method of employment.
8. Letters or recorded phone calls.
9. Fingerprints.
10. Casts.
11. Soil and mineral specimens.
12. Photographs of witnesses and curious bystanders.

250

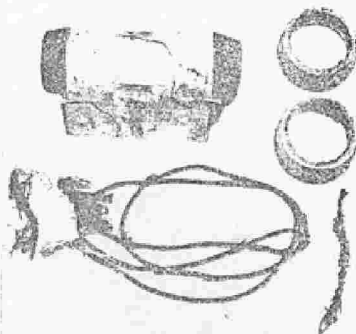

FIGURE 164. Evidence gathered at the scene of pipe bombing. (Courtesy Federal Bureau of Investigation)

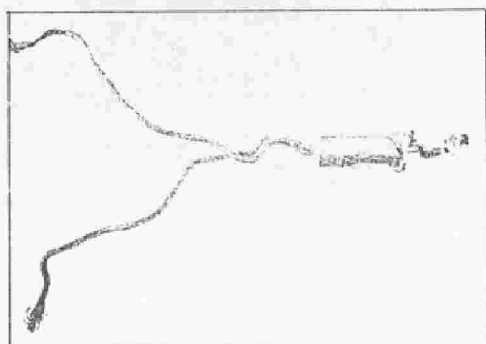

FIGURE 105. Electric blasting cap evidence found at the scene of a bombing. 251

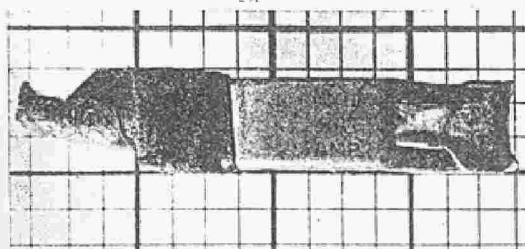

FIGURE 106. Electric alligator clip recovered in auto bombing. (Courtesy New York City Police Department Bomb Squad)

INGRAHAM... AUTOMATIC EIGHT- DAY ALARM CLOCK		IDENTIFIED FROM FRAGMENTS FOUND AT SCENE	
A - PARTS / CLOCK FOUND - SCENE	B - PARTS / CLOCK IDENTIFIED	A - PARTS / CLOCK FOUND - SCENE	B - PARTS / CLOCK IDENTIFIED



FIGURE 107. Fragments of clock recovered at bombing scene. Note step by step reconstruction. (Courtesy New York City Police Department Bomb Squad)

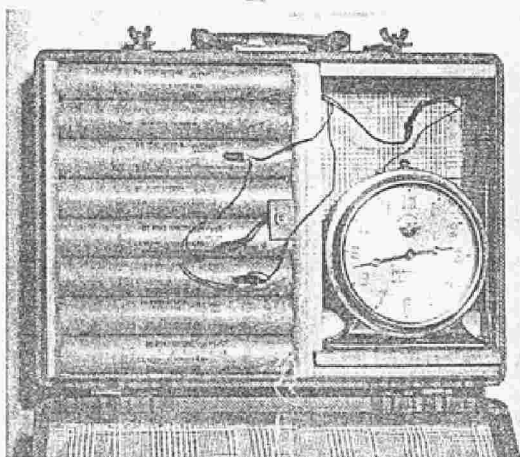

FIGURE 108. Clock bomb which was reconstructed from evidence at scene in Figure 107. (Courtesy New York City Police Department Bomb Squad)

Preservation of Evidence

Normal preservation techniques may be applied but certain hazards exist when dealing with explosives, acids, etc. and care should be taken when collecting these items. The following general steps should be observed for best results:

1. Care and proper packing.
2. Marking and identification.
3. Hazardous markings, acids, explosives, etc. (permanent ink).
4. Shipping regulations.
5. Concise letters of information.
6. Request receipts.
7. Film preservation (polaroids, etc.).
8. Records or recording tape data.

254

REQUIREMENTS FOR A BOMB DISPOSAL AREA

Federal laws, ICC regulations, Bureau of Mines, state, and city laws will normally govern the actual construction and use of a bomb disposal area, or cemetery, as it is often called. Care should be exercised in the storage of certain incompatible items within this area and area markings and security are of prime importance if an item is to be stored for lengthy periods of time. The pamphlets published by the Institute of Makers of Explosives and other references listed in the reference section of this book will also serve as good guides for disposal areas. The following specifications may serve as a general guide for a good disposal area.

The ideal terrain for a bomb disposal site would be a natural deep "bowl" or a low area surrounded on all sides by a high ridge and free from vegetation, traffic, and buildings; where an explosion would do no damage. I realize this is not possible near

most large incorporated areas, so we may use the following specifications as guides.

1. The center of the area must be at least 100 yards from the nearest inhabited building or thoroughfare which cannot be closed to traffic.
  2. The general public must be denied access to the area at all times.
  3. There must be no water main or gas main within fifty yards, and no storage reservoir within one-fourth of a mile.
  4. There must be an access road and road to the center of the site, both of which will bear four tons of weight.
  5. The disposal area should be located as near as possible to the perimeter of the city, in order to reduce transportation difficulties. It may be necessary in large cities to establish more than one, perhaps one on each side to facilitate disposal operations.
  6. The area should be reached by routes which avoid passing important structures, and have easy grades and good road surfaces.
  7. The area should not be liable to flooding.
  8. The site should be barren of trees or other objects subject to penetration or fire by hot, flying fragments.
- 255
9. Water and electric power (low voltage) should be available, if possible.
  10. Magazines and storage dumps should be provided.
  11. The area should be located out of the danger radius of high output transformers, radar, and high voltage tension lines.
  12. A protective fragment-proof shelter or tank should be provided for shelter to the disposal squad within 1000 yards of the disposal site.
  13. A structure on the area, but not nearer than 800 yards from the center, can be useful as a storage site.
  14. The area must be at least five miles from the nearest air-drome and must be off center from established airline routes.
  15. Wire and radio communications should be available during all disposal operations, bearing in mind that transmitters are "off" during disposal operations.
  16. Adequate markers and red flares should be displayed throughout the area during and after disposal operations.
  17. Adequate improvised burning pits should be constructed within the area for disposal of small arms, pyrotechnics and like devices. (Figure 169)

#### Small Arms Burning Pit

Small arms, small percussion primers, small fuzes, and certain detonators may be burned for disposal in what is known as a small arms burning pit, located in the disposal area. The "pit and chute" method is perhaps the best type of burning pit, although care should be exercised during burning operations as certain hazards exist.

A pit approximately six feet square and four feet deep is dug. An inclined chute, such as a piece of six inch pipe should be placed at an angle so that one end is over the center of the pit and the other end is behind a sand bag or cement barricade higher than a man's head. The chute end for pouring should be baffled inside with a no-return hinged type baffle plate as it may act as a rifle barrel for hot fragments flying out. The pipe must be secured and braced properly or damage will occur.

256

A hot fire should be built in the pit using damage or a fuel oil supply tank and the pit should be covered with sheet iron or

other material suitable for containing the flying fragments. Vent holes must be provided for proper draft. If a burning pit cannot be constructed, a trench two feet deep and one foot wide may be used for an improvised burn pit. A burning pit diagram is shown in Figure 169.

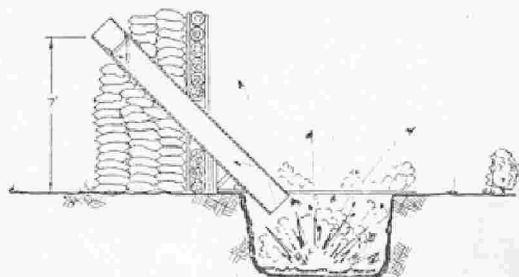

FIGURE 169. Small arms burning pit (Pit).

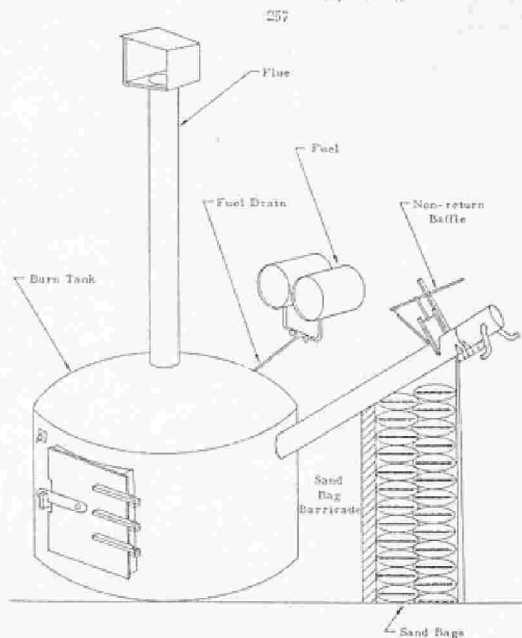

FIGURE 170. Burning pit.

A very modern burning pit designed by J. Haynes. An extremely good design and very modern.

#### Burning Operations

A dipper should be used to feed small arms, primers, and small detonators through the pipe chute. If primers, detonators, etc., are being fed into the pit, only one dipper at a time is used and the explosion must be heard before a second dipper is fed in.

258

If no explosion is heard, the operation should be discontinued for thirty minutes and then more fuel added to the pit.

It is essential to have a good hot fire before burning operations begin and never overload a pit with any type of munitions.

Otherwise a detonation may occur, creating serious damage and bodily injury. It is also important to know the exact characteristics of the munition being destroyed.

#### VEHICLES AND SPECIAL EQUIPMENT

This section is devoted to items of equipment normally utilized by larger metropolitan units and may be termed "special equipment." Certain areas, regardless of population, may have a need for this type of equipment should a bombing wave arise. In some areas, smaller departments have been known to improve their vehicles by use of trailers filled with sand.

##### Bomb Carrier Vehicles

Two types of bomb carrying vehicles are currently in use. Those being the "cage" type enclosed carriers, and the "vent" type open carriers. Both vehicles seem to do a good job of transporting limited amounts of explosives at a minimum risk to the general public.

The amount of explosives that these vehicles will safely carry is restricted and normally is considered confidential by the department using them. General information on specifications for these vehicles is furnished in this chapter to serve as a guide for peace officers. Detailed information can be obtained by writing to the manufacturing concerns if a department is interested in procuring the carriers.

One prime factor to remember regarding bomb transportation is to never carry a live bomb in the same vehicle in which you are riding. If necessary, use a trailer or detached type of carrier. If a blast should occur you will not receive the brunt of the shock or blast wave.

The specific carriers are:

1. **Cage type** (steel woven cable) vehicles—These vehicles are constructed of two cages, one inside the other, and are woven with flexible steel cable. The weave resembles a basket weave

and, should an explosion occur, the air spaces plus the flexible cable will allow for blast expansion. These provide a simple means of containing shrapnel or fragmentation and, at the same time, can vent off high pressures created by a detonation. They also serve psychologically to inform the saboteur or "mad bomber" that we have a means of safely transporting his device in an efficient manner. The New York City Police Department Bomb Squad uses the vehicle described above and illustrated in Figure 171.



FIGURE 171. Cage type bomb carrier (basket weave cable). (Courtesy New York City Police Department Bomb Squad)



FIGURE 172. Rear view of cage type bomb truck. Note inner woven basket

2. **Vented (open type) vehicles**—This type of vehicle consists of an open bed truck which has sand placed in the bed. An open, circular container is placed in the sand and, should the bomb explode, the blast will be cushioned and the pressure theoretically will be vented upwards.

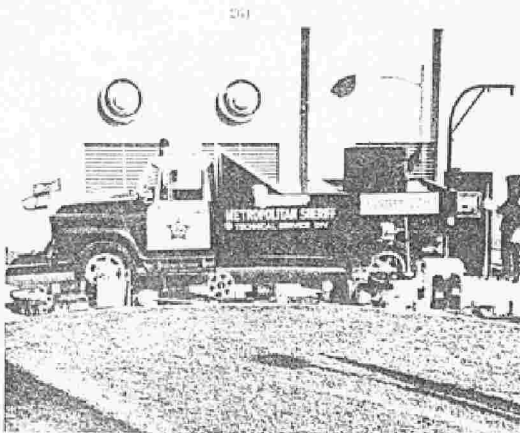

FIGURE 173. Vented or open vehicle. Blast and fragments are deflected upwards.

##### Portable Hand Bomb Carriers

This carrier, made of steel cable,  $\frac{3}{8}$  inch in diameter, shaped into the form of a vest with a snap lock over-rib. Two large

upper links are provided through which to insert a long steel pole for a two-man carry. The frontispiece of this book illustrates two officers filling the envelope device on a suspected package. If a detonator occurs in small packages the fragments are, for the most part, contained in the basket and high pressures are vented through the woven openings (Figure 174).

262

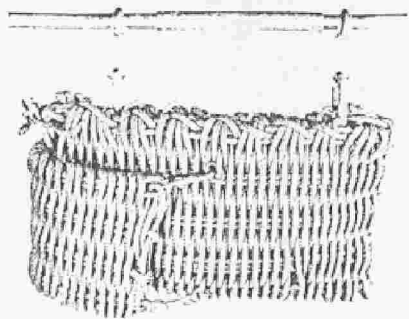

Figure 174. Portable hand bomb carrier.

OTHER SPECIAL EQUIPMENT

Protective (armor) Clothing

Certain larger bomb squads today maintain armor types of clothing to wear as an extra precaution against blast and fragments, should a small bomb detonate while in transit. This equipment, if available, would certainly reduce the casualties of a bomb squad if an explosion should occur near the working unit. The following illustrations show various items of armor type clothing available to bomb squads. If further data is required information can be obtained by writing to: Federal Laboratories, Saltsburg, Pennsylvania.

263

THE FOLLOWING CHART SHOWS THE RESULTS OF ACTUAL TEST FIRINGS AT 2-PLY MODEL P ARMOR PLATE PANELS USED IN FEDERAL SPOONER ARMOR PROTECTIVE EQUIPMENT

GUN	AMMUNITION				RESULTS
	Description	Velocity Muzzle	F.P.S. 50 Yards	Energy 50 Yards	
Thompson Sub-Machine Gun Cal. .45	#450 Peters .45 Auto. Metal S. Case; 230 grain.	830	810	335	Dimple. No penetration. No cracking.
.38 .44 Heavy Dury S. & W. four inch barrel.	#3844 Peters .38 spec. Lead. 158 grain.	875	820	296	Dimple. No penetration. No cracking.
.38 .44 Heavy Dury S. & W. four inch barrel.	#3846 Peters .38 spec. H. V. 115ccs Federal Metal Piercing. 110 grain.	1,280	1,130	312	Dimple. No penetration. No cracking.
.357 Magnum S. & W. five inch barrel.	#3575 Peters .357 Magnum H. V. lead 178 grain.	1,190	1,255	354	Dimple. No penetration. No cracking.
.357 Magnum S. & W. five inch barrel.	#3572P Western .357 Magnum Metal Piercing. 178 grain.	1,430	1,255	351	Dimple. No penetration. No cracking.

Figure 175. Ballistic chart, showing penetration factors on armored clothing. (Courtesy Federal Laboratories)

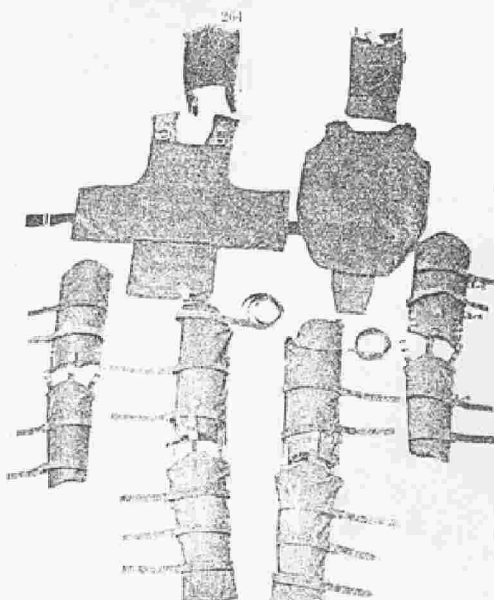

Figure 176. Layout of protective armor clothing.

265



Figure 177. Officer fully clothed in protective clothing

X-ray Equipment

Special types of X-ray and fluoroscopic equipment are available and in use by major bomb squads today. This equipment normally requires special training and provides a means to view suspected packages, prior to performing a rendering safe procedure. The new age of Polaroid film also speeds up the process and certain items can be photographed and viewed within ten minutes. Fluoroscopes provide an instant means of viewing but the operator must put himself in close proximity to the suspected device. The following illustrations show some equipment currently in use.

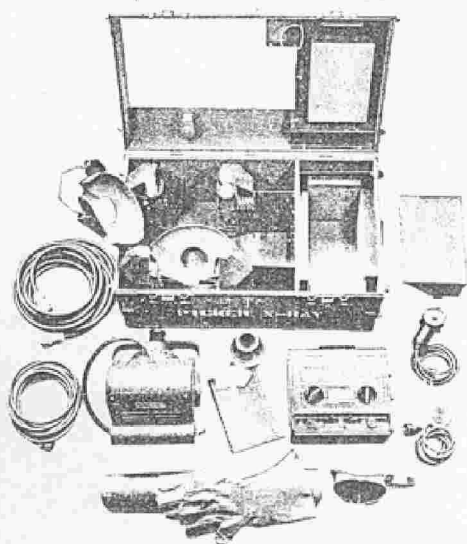

FIGURE 178. Portable field unit X-ray machine. (Courtesy Picker X-ray Co.)

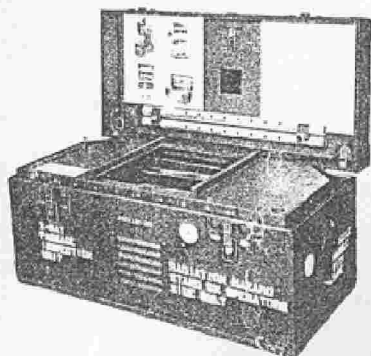

FIGURE 179. Portable X-ray fluoroscopic unit. (Courtesy Picker X-ray Co.)

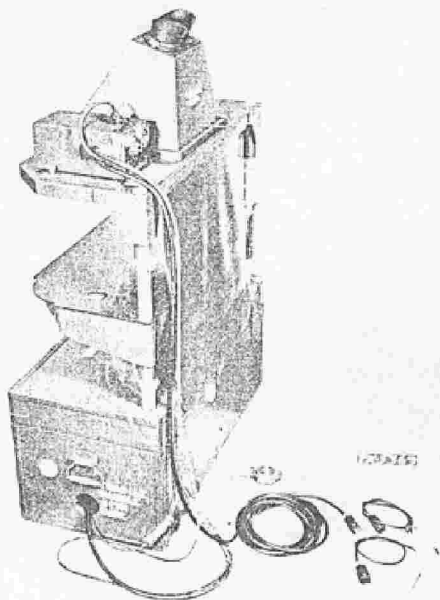

FIGURE 180. Portable X-ray fluoroscopic unit, assembled. (Courtesy Picker X-ray Co.)



FIGURE 181. Operator shown inspecting package with portable fluoroscope. (Courtesy Picker X-ray Co.)



270

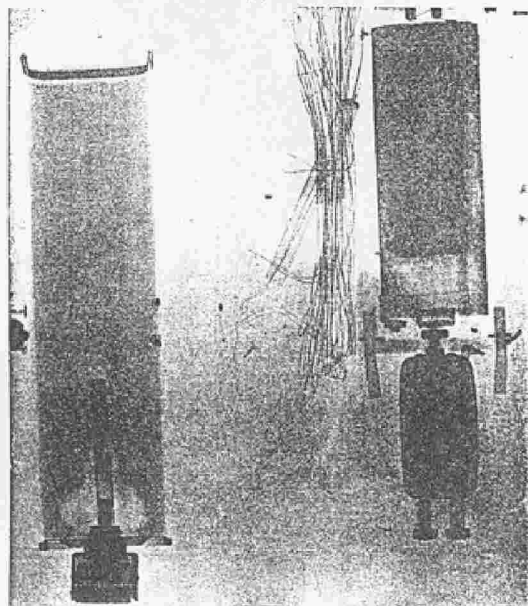

FIGURE 182. X-ray photo of suspected package. Note blasting caps in center and upper right of picture.

271

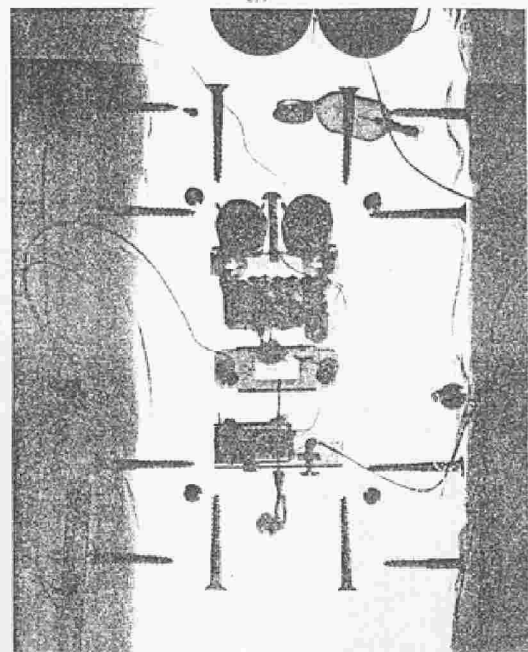

FIGURE 183. X-ray photo of clandestine package showing radio receiver unit. Note blasting caps left and right side of package.

272  
APPENDIX A  
GLOSSARY

**Ammunition**—The projectiles thrown against an enemy; such as bullets, shells, grenades, bombs, or mines.

**Anti-disturbance**—A device placed into an explosive unit designed to function the mechanism on any attempt to jar, tilt, or move the unit. Examples: a sensitive vibratory switch or anti-tilt (mercury switch).

**Anti-lift**—A mechanism used to fire an explosive device when the primary object is lifted or tilted.

**Anti-personnel**—In munitions or warfare, anti-personnel refers to the devices or munitions designed for use against personnel or troops.

**Anti-tank**—In mine warfare, anti-tank refers to the mines designed to immobilize or destroy tanks and tracked vehicles.

**Anti-withdrawal**—A device or feature which prevents the removal of a fuze or triggering mechanism from an explosive device. Examples: placing epoxy cement in the fuze threads, employing a lock ball or wedge, or welding the fuze into the device to prevent removal.

**Anti-withdrawal/booby trap**—A device which locks the fuze into place and is designed to function the explosive on attempted removal of the fuze system.

**Armed**—In munitions, the condition of being ready to function; that is, all explosive components are aligned, and/or all electrical connections are completed ready for firing. In straight mechanical devices, this could be removal of safety pins or lock devices.

**Arming**—The action involving removal of safety devices or arranging components from a safe condition to a state of readiness for initiation.

**Arming delay**—The pyrotechnic, electrical, chemical, or mechanical action which provides a timed delay between the initiating action and complete alignment of all firing components. Usually installed in explosive devices to allow the perpetrator a safety margin for arming the device.

**Armed and functioning**—In a timed explosive device, the unit (electrical, chemical, or mechanical) has started and is moving towards the firing time.

**Baffle**—A wall or screen used to deflect, check, or otherwise defeat an explosive shock wave. Example: mattresses placed around an explosive device.

273

**Blasting**—The use of explosives to shatter or destroy.

**Blasting cap**—A small pencil-like cylindrical case with a thin wall in which is enclosed a sensitive high explosive, such as mercury fulminate, used as a detonator to set off the main charge explosive in a device. They are normally fired by safety fuze, electric current, or chemical action. Containers for blasting caps are found constructed of copper, aluminum, or plastic.

**Blasting time fuze**—Consists of a fabric cord containing black powder and is used in blasting to obtain a timed delay for firing blasting caps. Time is usually 30-15 seconds per foot. Time fuze is also called safety fuze.

**B. D.**—The abbreviation for "Bomb Disposal."

**Booby trap**—An explosive device, which is exploded when an unsuspecting person disturbs an apparently harmless object or performs a presumably safe action.

**Booster**—A high explosive element, sufficiently sensitive to be actuated by a small explosive element in a fuze or firing device, and powerful enough to cause detonation of a main explosive charge. In a firing train, the order is usually primer, detonator, booster, and main charge.

**Brisance**—In explosives, brisance refers to the degree of shattering effect exerted by the explosive. Example: tetryl explosive by its rapid detonating rate is far more shattering in nature than ammonium nitrate.

**Bursting charge**—The internal charge or explosive of a device which breaks the casing of a shell, grenade, rocket, or bomb to produce

demolition, fragmentation, or chemical action.

**Buttressing**—In bomb disposal operations, this refers to the measures taken to provide support, by means of a buttress, to prevent earth shock and blast damage to structures. Example: sand bags or loose sand poured against walls or around an explosive device.

**Cartridge**—A case, capsule, shell, or bag of metal, containing the explosive charge or propelling charge. Example: a small arms cartridge made of brass and containing the primer, propellant and projectile.

**Cast**—In explosives, the types which are melted and formed by pouring into a mold to harden. Example: TNT which is melted and poured into a bomb case for hardening.

**Cavitation**—In explosives, the formation of a cavity or indentation by means of a cavity or shape charge. The cavitation being caused

274

by the explosive jet and slug. Example: the Munroe shape charges.

**Cavity containers**—Also known as shape charges, and are the geometric cavity and suitable liner with stand-off for deep penetration into a steel or concrete object. It normally consists of a container, cavity liner (cone), an explosive charge, and stand-off distance.

**Clandestine device**—A device made and conducted with secrecy by design usually for an evil or illicit purpose.

**Cocked striker**—Also called a firing pin. Consists of a blunt or sharp pin held under spring tension and designed to fire a primer or detonator by stab, friction, or percussion action when released.

**Compound**—In explosives, the mixtures used in the manufacture of an explosive device or explosive itself.

**Contrived explosive**—Refers to an explosive which is improvised by use of fuels and oxidizers as compared to a commercially manufactured explosive.

**Cook-off**—An explosive or munition which upon initiation fails to fire but due to excessive heat will eventually function at an unexpected time.

**Cordtex**—Also called primacord or detonating cord. Consists of a reinforced tubular structure containing a high explosive and is used to transmit a detonating wave from one place to another.

**Counter charge**—In disposal of explosives, counter charge means placing one explosive charge against another for purposes of detonating the charges.

**Dud-fired**—In ordnance terms, this means a munition which has undergone a complete arming and firing cycle but, due to a malfunction, has failed to explode or function.

**E. O. D.**—A military abbreviation for "Explosive Ordnance Disposal."

**Detonation**—A term usually associated with high explosives, meaning to explode with sudden violence. A low explosive would normally create a sudden explosion by rapid expansion of gases by burning, whereas a high explosive would detonate violently by a sudden chemical change, resulting in a brilliant explosion.

**Disarming**—The act or process whereby explosive items are made safe by proper replacement of all safety devices or by separation of various components in the firing train.

**Desensitizer**—Any compound used to reduce the sensitivity of an explosive. Examples: gelatin, starch, sawdust, acetone, etc.

275

**Detonating cord**—A cord-like explosive with a fabric cover containing a core of high explosive used to transmit a detonating wave. The exterior has a waxy appearance and is initiated by means of a blasting cap. Also called cordex or primacord. Colors and materials of detonating cord are variable.

**Detonator**—A sensitive high explosive element used in an explosive train to create or transmit a detonating wave to a booster or a main charge of high explosives. Example: a blasting cap.

**Deflagration**—A rapid burning. Low explosives are said to deflagrate whereas high explosives are known to detonate.

**Demolition**—The act of demolishing. However, in explosives terminology, demolitions could mean the explosives and tools needed for

explosive demolition works.

**Desensitized**—Refers to a normally high sensitive explosive which is desensitized by means of a compound added to reduce sensitivity. Example: nitroglycerin desensitized by adding gelatin to form gelatin dynamite.

**E. S. P.**—A military abbreviation for "Electrical Safing Procedure." An example would be removal of batteries or cutting and taping certain individual leads in a circuit.

**Explosion**—A chemical or mechanical action resulting in a sudden bursting accompanied by a loud noise. A rapid expansion of gases or simply a "loud boom and a sudden going away of things from where they have just been."

**Explosive**—An explosive substance burning or detonating with violence; such as gunpowder, TNT, ammonium nitrate, etc.

**Explosive train**—The steps in which the explosives are aligned to initiate a munition or explosive device; such as a primer, detonator, booster, and main charge. Also called a firing train.

**"Fire in the hole"**—An expression or warning used by bomb disposal and demolition personnel just prior to detonating or exploding a device to warn personnel in the vicinity of the danger.

**Firing device**—A mechanism designed to initiate a fire train in an explosive device or munition. It is often called the fuse when completely assembled and consists of the basic mechanism needed to initiate or trigger the explosive.

**Firing delay**—Basically the same as an arming delay but consists of a pyrotechnic or chemical used to delay the explosion after the initiating action has taken place.

**Firing pin**—A sharp or blunt pin used to initiate a sensitive explo-

276

sive; such as a primer by stab action, friction, or percussion.

**Firing train**—See Explosive Train.

**"Fougasse"**—A military term which refers to an improvised incendiary or explosive device, usually buried, and designed for use against personnel.

**Fragmentation**—Means separation into segments or parts, and in military munitions it means an encased item with a bursting charge which will break the case into fragments. Example: a fragmentation hand grenade.

**Freezing**—A disposal technique using dry ice, liquid oxygen, liquid nitrogen, CO<sub>2</sub> and alcohol to lower the firing potential of batteries or to slow down certain chemical fuse actions; such as acetone.

**Fuel**—In explosives, a compound added to provide the basis for an explosion. Nearly all explosives require a fuel to sustain burning and an oxidizer to provide oxygen.

**Fuse**—Normally a pyrotechnic burning time fuse of black powder, used in blasting operations.

**Fuze**—A mechanical, chemical or electric device which produces the initial action to trigger a munition or explosive device.

**Fuzee**—A burning flare or pyrotechnic device used by railroads, autos, etc., to give warning. Usually will burn with a bright flame for illumination.

**Fuze lighter**—A device containing a flash primer which is used in blasting operations to ignite safety fuse. Most fuze lighters use friction or percussion methods of ignition.

**Fuze well**—In munitions, a cavity threaded or un-threaded extending into the munition to accept the fuze or firing device.

**Gag**—A bomb disposal term which refers to techniques used to immobilize movable components on firing systems, clocks, etc., to prevent further movement. Examples: plaster of Paris and water applied to a movable plunger, or syrup injected into a clock to stop the action.

**Greek fire**—An ancient incendiary mixture used as far back as the year 670. It consisted of saltpeter, sulphur, and pitch blends which could hurl the burning incendiaries into ships with a mortar-like device.

**Grenade**—A bomb or small shell filled with explosives, gas, etc., and designed to be thrown or projected in some fashion at a target.

**Hell Box**—Often termed a "Blasting Machine" and consists of a gen-

erator, hand operated, which is used to electrically initiate blasting caps in explosive operations. <sup>257</sup>  
A hand operated or battery operated generator.

**High order**—A successful and complete detonation of an explosive with the entire consumption or detonation at its maximum rate of the explosive being detonated.

**Hoax bomb**—A fake bomb designed by an individual to give the appearance of a high explosive bomb or to frighten personnel by its appearance.

**Hygroscopic**—Means the ability to readily absorb and retain moisture. Example: black powder which readily accepts moisture because of its porous structure.

**Hypergolic**—Means self-igniting. A term used in the military towards certain chemicals or compounds which, when combined, tend to burst into flames or react with explosive violence on contact. A good example is potassium chlorate and sugar in contact with sulphuric acid, which will cause an immediate explosion.

**Ignition train**—A flammable train used by bomb disposal personnel to ignite powders or explosives and is usually about twenty-five feet in length. It could consist of exclusion, burning time fuse, or any slow burning material for safety reasons.

**Inciendary**—A burning compound or metal used to produce intense heat. Examples: thermite or magnesium.

**Infernal machine**—A machine or apparatus maliciously designed to explode or destroy life and property.

**Improvised mine**—An explosive device manufactured and designed from locally available materials. Not of standard manufacture. Example: a pipe bomb filled with black or smokeless powder.

**Initiator**—That part of an explosive train which starts or initiates; such as a primer or detonator. The fuse, in certain instances, could be considered the initiator or first action.

**Initiating action**—The first action in a normal firing train which starts the device into motion. Examples: pressure on a plunger, pull on a slack wire, or cutting a tight wire (called tension release), etc.

**Linear charge**—Basically the same as a cavity charge, except the cavity is arranged in a line to produce a cutting effect rather than a pinpoint penetration of the object.

**Long delay**—A military term associated with fuzes which incorporate a delay feature extending from minutes to hours. Some long delay fuzes can run to 126 days in time.

278

**Low order**—The incomplete initiation of an explosive or one which has detonated at less than its maximum rate. The explosive usually fails to detonate because of deterioration, insufficient detonating wave, separation of explosive, or like causes.

**Main charge**—Also called the bursting charge and is usually associated with the main explosive filler of a munition.

**Mine**—A cased or uncased explosive, chemical agent, or incendiary designed to destroy or damage vehicles, boats, aircraft, or designed to wound, kill, or otherwise incapacitate personnel. It may be detonated by the action of its victim, by time, or by controlled means.

**Missile**—A spear, arrow, bullet, rocket, or bomb capable of being thrown or projected to strike an object.

**Molotov Cocktail**—A crude incendiary hand grenade filled with an inflammable liquid, chiefly gasoline, and fitted with a wick or like ignition device which ignites the device upon impact with its target.

**Mortar**—A short tube used to throw projectiles with low velocities at high angles.

**Mustard**—A chemical agent known as a blister agent, used during World War I as a war gas. This agent produces large blisters on contact, creates blindness, and affects lungs.

**Neutralize**—The act of making neutral or rendering safe a device by insertion of safety pins, separation of components, etc. Also referred to as an RSP (Rendering Safe Procedure).

**Oxidizer**—An oxygen-bearing compound used in the manufacture of explosives; such as potassium nitrate or chlorate, to produce fast

burning internally of a device. The oxidizer supplies the oxygen needed for the internal combustion or detonation of the item.

**Percussion**—Sensitive to mechanical shock; such as a rifle percussion cap or primer. It fires upon being struck by a blunt firing pin. The percussion primer usually transmits a flame to a propellant or detonator.

**Photo-flash**—Often called flash powder, which is extremely sensitive to heat, shock, or friction and is often used as a main charge in clandestine devices. A good example of the brilliance of photo-flash is the common "cherry bomb" which explodes with great violence.

**"Pineapple"**—A slang term for a dynamite bomb, hand grenade, or like improvised device.

**Plastic bomb**—An explosive device manufactured using the newer pliable or plastic (putty) type explosives. Often used by terrorists because of its flexibility.

279

**Plastic explosive**—A pliable, putty-like explosive which can be molded into various shapes and much resembles wood putty. In military terms, these are called the composition explosives; such as C-3, C-1, etc. and range in color from yellow to white.

**Powder train**—The alignment of a group of powders to produce a desired effect; such as a powder train delay with a powder propelling charge designed to hurl a mine into the air after a pre-determined delay period.

**Primacord**—See Detonating Cord or Cordex.

**Primer**—A small cylindrical metal device containing a primary high explosive, which is detonated by means of a firing pin, and produces the flame or explosion needed to detonate a detonator or ignite a propellant in a normal firing train. The two types of primers are percussion and stub types. A good example of a primer is the type found in the base of a standard shotgun shell which, upon being struck, will ignite the propelling charge ejecting the bird shot of the shell.

**Priming**—Indicates the methods used to set up an explosive charge for firing; such as inserting the blasting caps for a detonation.

**Projectile**—A missile, either solid or with an explosive, chemical, or inert filler propelled from a weapon by the force of gases produced by the propelling charge. Example: an artillery projectile.

**Propellant**—An explosive which rapidly burns and propels a projectile from a gun tube. Another example is a liquid propellant used to propel a missile or rocket into the air.

**Protective measures**—Those measures taken for protection against chemicals or explosives during disposal and rendering safe operations on bombs and like devices. These may include shelter, full protective clothing, and certain other precautions; such as chemical, or fragmentation precautions.

**Psychotic bomber**—A person, considered insane by normal standards, who contrives an explosive or incendiary device to be used for an evil purpose against society.

**Pyrotechnic**—Modifications of fireworks designed to produce a brilliant light for illumination or to produce colored lights or smoke for signaling purposes.

**Quick-match**—A very rapid burning time fuse often used in blasting operations to ignite time or safety fuzes. Quick-match fuzes can be very rapid in burning—some are timed at one foot per second.

280

**Rendering Safe Procedure (RSP)**—The tools and methods employed against an explosive device or munition designed to neutralize or otherwise make safe the fuzing system, so that it can be assumed safe for transportation and disposal. Any method which could detonate or initiate the munition would not be considered a true rendering safe procedure in bomb disposal circles.

**Sabotage**—Derived from the term to "Tread with a wooden shoe." Means the malicious waste or destruction of an employer's property by workmen, or by an enemy agent, or destructive acts designed to impede the armed forces or essential war industry by neglect or by actions.

**Safety fuse**—A cord containing a continuous core of black powder. It is used to carry flame at a uniform rate to an explosive charge and is usually waterproofed. Burning time is usually 30-45 seconds per foot. Also called time fuse.

**Shape charge**—See Cavity Container. Also called cavity charge, using Munroe effect.

**Shells**—In munitions, artillery projectiles and various projected rounds are called shells.

**Shrapnel**—Pre-cut or pre-formed cubes, darts, or ball bearings placed into or attached to an explosive device for use against personnel or material.

**Small arms**—Defined as ammunition fired in weapons whose bores are 0.60 inch or less in diameter. Example: 22 caliber round.

**Solvent**—In explosives disposal, those solvents which will soften and dissolve certain explosives. Example: acetone/TNT.

**Spray**—During munitions disposal using explosives, a spray is considered to be certain unexploded devices which will fly out of the site of detonation. This usually is the result of poor priming procedures or insufficient explosives to create a complete detonation. A munition which has sprayed is usually quite hazardous due to powdered high explosives.

**Squib**—A small pencil-like tube containing black powder used to transmit a flame to ignite certain devices. Squibs resemble blasting caps in appearance and are used for many purposes; such as to ignite socket igniters, initiate ejection seats in aircraft, or to ignite propelling charges.

**"Stand-off"**—The distance provided between the cavity or cone of a shape charge to allow formation of the jet before contact with the

281

target is made. The stand-off distance is determined by the size and shape of the cavity container.

**Striker**—A blunt or sharp pin, also called a firing pin.

**Sub-missile**—Small sphere-like missiles placed inside a carrier or container and designed to be hurled from the container or ejected in some fashion at or near the target. The sub-missiles may be fuzed to fire on impact with the target or in the air near the target.

**Sympathetic detonation**—A detonation occurring from one explosion, transmitting a wave to another nearby explosive, in turn causing it to detonate.

**Terrorist**—One who uses explosives or clandestine means to demoralize a government or area by terrorist means. Usually an agent, partisan, or member of a party.

**Timbering**—In bomb disposal, the act of placing wooden beams into an excavation for support.

**Timing disc**—A small spring-wound disc found in military fuzes and using a clock work mechanism. The rotating disc provides the means to release a spring-loaded firing pin at the prop-a time. They are found in fuzes called clockwork aerial burst or mechanical time.

**Trepan**—To cut through or gain access or entrance by cutting, sawing, or corrosive acid action.

**Trigger**—Basically the same as a fuse. The device in a firing train which starts the initiation or initiating action.

**Trip wire**—A small fine wire attached to a standard or improvised firing device designed to initiate the fuse as a unsuspecting person breaks or pulls the wire.

**U. X. B.**—A military abbreviation for "Unexploded Bomb."

282

## APPENDIX B

### TECHNICAL REFERENCES, CONSULTANTS, BOOKS, GOVERNMENT MANUALS, AND EQUIPMENT MANUFACTURERS

## GOVERNMENT BOOKS AND FIELD MANUALS

TM 5-280, entitled *Foreign Mine Warfare Equipment*

TM 9-1900, entitled *Ammunition General*

TM 9-1903, entitled *Case, Handling, Preservation and Destruction of Ammunition*

TM 9-1904, entitled *Ammunition Inspection Guide*

TM 9-1910, entitled *Military Explosives*

FM 5-25, entitled *Explosives and Demolitions*

FM 5-31, entitled *Engineer Field Data*

FM 9-40, entitled *Explosive Ordnance Reconnaissance*

FM 23-30, entitled *Hand and Rifle Grenades*

OP 5, Vol. 1, entitled *Ammunition Ashore: Handling, Stowing and Shipping* (A Bureau of Ordnance, Department of Navy Publication).

*Encyclopedia of Explosives*, Ordnance Liaison Group, Durham Box CM Duke Station, Durham, North Carolina.

*The Effects of Nuclear Weapons*, by Samuel Glasstone, c/o U.S. Atomic Energy Commission.

(NOTE: Information on this publication and other Government publications can be obtained by writing to: U.S. Government Printing Office, Superintendent of Documents, Washington, 25, D. C.

## COMERICAL PUBLICATIONS

*The Chemistry of Powder and Explosives*, by Tenney L. Davis, John Wiley & Sons, Inc., New York.

*Elements of Ammunition*, by O. Hart, John Wiley & Sons, Inc., New York.

*Manual of Explosives, Military Pyrotechnics, and Chemical Warfare Agents*, by J. Bebler, MacMillan Publishing Company, New York.

*The Chemical Encyclopedia*, by G. S. Clark and G. G. Hawley, Reinhold Publishing Company, New York.

*Explosives, Matches and Fireworks*, by J. Reilly, De Van Nostrand Company, New York.

283

*The Science of High Explosives*, by M. A. Cook, Reinhold Publishing Company, New York.

*Dangerous Properties of Industrial Materials*, by N. Irving Sax, Reinhold Publishing Company, New York.

*The Blasters Handbook*, E. I. Du Pont de Nemours and Company, Inc., Wilmington, Delaware.

*Pamphlets, Books and Periodicals on Explosives and Related Items*, published by The Institute of Makers of Explosives, New York.

*Ammunition, Powder and Explosives*, four volumes, Picatinny Arsenal, Dover, New Jersey.

*Explosives—Their Anatomy and Destructiveness*, first edition, McGraw Hill Book Company, New York.

*High Explosives*, by E. Colver, De Van Nostrand Company, New York.

## EXPLOSIVE ITEMS AND EXPLOSIVE MANUFACTURERS

American Cynamid Company, Bound Brook, New Jersey.

Apoche Powder Company, Benson, Arizona.

Atlas Chemical Industries, Inc., Wilmington, Delaware.

Austin Powder Company, Cleveland, Ohio.

E. I. Du Pont de Nemours and Company, Inc., Wilmington, Delaware.

The Ensign Bickford Company, Simsbury, Connecticut.

Hercules Powder Company, Wilmington, Delaware.

National Powder Company, Eldred, Pennsylvania.

Pacific Powder Company, Seattle, Washington.

## ASSOCIATIONS AND ORGANIZATIONS

The Institute of Makers of Explosives, 250 East 43rd Street, New York 17, New York.

The American Ordnance Association, Milk Building, Pennsylvania at 17th, Washington 6, D. C.

### ORDNANCE EXPERTS FOR RESEARCH AND CONSULTATION

*Loud Mines, Clandestine Devices, Sabotage and Booby Traps*, Robert R. Levy, P. O. Box 142, Indian Head, Maryland. Fee for research, unclassified information only.

*General and Air Rockets and Hand Rifle Grenades*, Carl E. Johnson, 284

No. 2 Circle Ave., Potomac Heights, Maryland. Fee for research, unclassified information only.

*Civil War Munitions, Aircraft Ordnance, Radiation Detection Instruments, Contamination Control*, Charles R. Newhouser, 525 Gondoliere, Coral Gables, Florida. Fee for research, unclassified information only.

*Small Arms and Projected Munitions*, John H. Blye, III, 1902 Graham Street, Montgomery, Alabama. Fee for research, unclassified information only.

*Chemicals and Chemical Munitions*, George A. Fischer, 1931 North Sheffield, Chicago 11, Illinois. Fee for research, unclassified information only.

### EQUIPMENT SUPPLY AND MANUFACTURERS

Portable Bomb Carriers, The New York Splicing Company, 311 Madison Street, Hoboken, New Jersey

Armor Vests, Hoods, and Related Equipment, Federal Laboratories, Salisbury, Pennsylvania

Portable X-ray and Fluoroscope Equipment, Picker X-ray Company, 75 Varick Street, New York 15, New York

Blasting Equipment and Supplies, E. I. Du Pont de Nemours and Company, Inc., Wilmington 98, Delaware

Electronic Stethoscopes and Related Equipment, Presto Recording Corporation, 212 West 55th Street, New York, New York.

285

### APPENDIX C

#### DEMOLITION AND DISPOSAL "DO'S AND DON'TS"

*Courtesy of The Institute of Makers of Explosives  
and The New York City Police Department*

After a prescribed course in demolitions has been completed under the guidance of trained demolition personnel, the following *do's* and *don'ts* should be followed during all operations involving explosives, and suspected packages.

#### WHEN TRANSPORTING EXPLOSIVES

1. DO obey all Federal, state and local laws and regulations.
2. DO see that any vehicle used to transport explosives is in proper working condition and equipped with a tight wooden or non-sparking metal floor with sides and ends high enough to prevent the explosives from falling off. The load in an open-bodied truck should be covered with a waterproof and fire-resistant tarpaulin, and the explosives should not be allowed to contact any source of heat such as an exhaust pipe. Wiring should be fully insulated so as to prevent short circuiting, and at least two fire extinguishers should be carried. The truck should be plainly marked so as to give adequate warning to the public of the nature of the cargo.
3. DON'T permit metal, except approved metal truck bodies, to contact cases of explosives. Metal, flammable, or corrosive substances should not be transported with explosives.
4. DON'T allow smoking or unauthorized or unnecessary persons in the vehicle.
5. DO load and unload explosives carefully. Never throw explosives from the truck.
6. DO see that other explosives, including detonating fuse, are separated from blasting caps and/or electric blasting caps where it is permitted to transport them in the same vehicle.

7. DON'T drive trucks containing explosives through cities, towns or villages, or park them near such places as restaurants, garages and filling stations, unless it cannot be avoided.
8. DO request that explosive deliveries be made at the magazine or in some other location well removed from populated areas.

286

9. DON'T fight fires after they have come in contact with explosives. Remove all personnel to a safe location and guard the area against intruders.

#### WHEN STORING EXPLOSIVES

10. DO store explosives in accordance with federal, state or local laws and regulations.
11. DO store explosives only in a magazine which is clean, dry, well ventilated, reasonably cool, properly located, substantially constructed, bullet and fire resistant, and securely locked.
12. DON'T store blasting caps, electric blasting caps, or primers in the same box, container, or magazine with other explosives. Detonating fuse should not be stored with blasting caps or electric blasting caps.
13. DON'T store explosives, fuse, or fuse lighters in a wet or damp place, or near oil, gasoline, cleaning solution or solvents, or near radiators, steam pipes, exhaust pipes, stoves, or other sources of heat.
14. DON'T store any sparking metal, or sparking metal tools in an explosives magazine.
15. DON'T smoke or have matches, or have any source of fire or flame in or near an explosive magazine.
16. DON'T allow leaves, grass, brush, or debris to accumulate within 25 feet of an explosives magazine.
17. DON'T shoot into explosives or allow the discharge of firearms in the vicinity of an explosives magazine.
18. DO consult the manufacturer if nitroglycerin from deteriorated explosives has leaked onto the floor of a magazine. The floor should be desensitized by washing thoroughly with an agent approved for that purpose.
19. DO locate explosive magazines in the most isolated places available. They should be separated from each other, and from inhabited buildings, highways and railroads, by distances not less than those recommended in the "American Table of Distances."

#### WHEN USING EXPLOSIVES

20. DON'T use sparking metal tools to open legs or wooden cases of explosives. Metallic slitters may be used for opening fiber-board cases, provided that the metallic slitter does not come in contact with the metallic fasteners of the case.

287

21. DON'T smoke or have matches, or any source of fire or flame, within 100 feet of an area in which explosives are being handled or used.
22. DON'T place explosives where they may be exposed to flame, excessive heat, sparks, or impact.
23. DO replace or close the cover of explosives cases or packages after using.
24. DON'T carry explosives in the pockets of your clothing or elsewhere on your person.
25. DON'T insert anything but fuse in the open end of a blasting cap.
26. DON'T strike, tamper with, or attempt to remove or investigate the contents of a blasting cap or an electric blasting cap, or try to pull the wires out of an electric blasting cap.
27. DON'T allow children or unauthorized or unnecessary persons to be present where explosives are being handled or used.
28. DON'T handle, use, or be near explosives during the approach or progress of any electrical storm. All persons should retire to a place of safety.

29. DON'T use explosives or accessory equipment that are obviously deteriorated or damaged.
30. DON'T attempt to reclaim or to use fuze, blasting caps, electric blasting caps, or any explosives that have been water soaked, even if they dried out. Consult the manufacturer.

#### WHEN PREPARING THE PRIMER

31. DON'T make up primers in a magazine, or near excessive quantities of explosives, or in excess of immediate needs.
32. DON'T force a blasting cap or an electric blasting cap into dynamite. Insert the cap into a hole made in the dynamite with a punch suitable for the purpose.
33. DO make up primers in accordance with proven and established methods. Make sure that the cap shell is completely encased in the dynamite or booster and so secured that in loading no tension will be placed on the wires or fuze at the point of entry into the cap. When side priming a heavy wall or heavy weight cartridge, wrap adhesive tape around the hole punched in the cartridge so that the cap cannot come out.

288

#### WHEN SHOOTING ELECTRICALLY

34. DON'T uncoil the wires or use electric blasting caps during dust storms or near any other source of large charges of static electricity.
35. DON'T uncoil the wires or use electric blasting caps in the vicinity of radio-frequency transmitters, except at safe distances. Consult the manufacturer or the Institute of Makers of Explosives' pamphlet on *Radio Frequency Hazards*.
36. DO keep the firing circuit completely insulated from the ground or other conductors such as bare wires, rails, pipes, or other paths of stray currents.
37. DON'T have electric wires or cables of any kind near electric blasting caps or other explosives except at the time and for the purpose of firing the blast.
38. DO test all electric blasting caps, either singly or when connected in a series circuit, using only a blasting galvanometer specifically designed for the purpose.
39. DON'T use in the same circuit either electric blasting caps made by more than one manufacturer, or electric blasting caps of different style or function even if made by the same manufacturer, unless such use is approved by the manufacturer.
40. DON'T attempt to fire a single electric blasting cap or a circuit of electric blasting caps with less than the minimum current specified by the manufacturer.
41. DO be sure that all wire ends to be connected are bright and clean.
42. DO keep the electric cap wires or leading wires short circuited until ready to fire.

#### WHEN SHOOTING WITH FUZE

43. DO handle fuze carefully to avoid damaging the covering. In cold weather warm slightly before using to avoid cracking the water-proofing.
44. DON'T use short fuze. Know the burning speed of the fuze and make sure you have time to reach a place of safety after lighting. Never use less than six feet.
45. DON'T cut fuze until you are ready to insert it into a blasting cap. Cut off an inch or two to insure a dry end. Cut fuze squarely across with a clean sharp blade. Seat the fuze lightly against the

289

cap charge and avoid twisting after it is in place.

46. DON'T crimp blasting caps by any means except a cap crimper designed for the purpose. Make certain that the cap is securely crimped to the fuze.
47. DO light fuze with a fuze lighter designed for the purpose. If a match is used, the fuze should be slit at the end and the match

head with an abrasive surface to light the fuze.

48. DON'T light fuze until sufficient stemming has been placed over the explosive to prevent sparks or flying match heads from coming into contact with the explosive.
49. DON'T hold explosives in the hands when lighting fuze.

#### BEFORE AND AFTER FIRING

50. DON'T fire a blast without a positive signal from the one in charge, who has made certain that all surplus explosives are in a safe place, all persons and vehicles are at a safe distance or under sufficient cover, and that adequate warning has been given.
51. DON'T return to the area of any blast until the smoke and fumes from the blast have been dissipated.
52. DON'T attempt to investigate a misfire too soon. Follow recognized rules and regulations, or if no rules or regulations are in effect, wait at least one hour.
53. DON'T drill, bore, or pick out a charge of explosives that has misfired. Misfires should be handled only by or under the direction of a competent and experienced person.

#### EXPLOSIVES DISPOSAL

54. DON'T abandon any explosives.
55. DO dispose of or destroy explosives in strict accordance with approved methods. Consult the manufacturer or follow the Institute of Makers of Explosives' pamphlet on destroying explosives.
56. DON'T leave explosives, empty cartridges, boxes, liners, or other materials used in the packing of explosives lying around where children or unauthorized persons or livestock can get at them.
57. DON'T allow any wood, paper, or any other materials employed in packing explosives to be burned in a stove, a fireplace, or other confined space, or to be used for any purpose. Such materials should be destroyed by burning at an isolated location out of doors and no person should be nearer than 100 feet after the burning has started.

290

#### SUSPECTED PACKAGES

1. DON'T submerge in water due to conductivity of electric circuits and possibility of violent reactions with chemical agents.
2. DON'T bring a bomb or suspected package into a station house or inhabited building.
3. DON'T indiscriminately shock or jar a bomb while transporting.
4. DON'T attempt to open a package by hand; always use remote means where possible.
5. DON'T cut a string or unlatch a box or package by hand due to the possibility of pressure release devices.
6. DON'T turn a box or cylindrical object by hand due to the possibility of sliding contacts, mercury switches or balanced pendulum fuzing systems.
7. DON'T transport suspected nitroglycerin in metallic containers - use plastic or clean glass containers well cushioned if transporting is necessary.
8. DON'T lay a bottle on its side as this may cause certain hypergolic chemicals to mix causing a mechanical explosion or violent reaction.
9. DON'T puncture or cut into a box with a metallic object as the possibility of an electric probe proof circuit may be employed.
10. DON'T accept identification markings on any suspected package as legitimate.
11. DON'T stereotype the bomb as being high explosive as the contents may be incendiary in nature.
12. DON'T transport a bomb through congested areas.
13. DON'T allow radio transmissions in the near vicinity of a suspected package.
14. DON'T pass metallic tools over or in the near vicinity of a suspected package until identification of its contents are made due to the possibility of a magnetic device.
15. DO use speed with caution in any suspected package due to the



possibility of a silent delay being employed.

16. DON'T work more than one man and a maximum of two per suspected device. One cardinal rule, however, is to work as a team keeping the number of personnel at a minimum on the actual device.
17. DO use protective clothing and safety glasses while working on a suspected package where time permits.

291

18. DON'T cut through any two wires or a double strand wire at one time and wear rubber surgeous gloves while working on electric circuits as the sweat of the hands could bridge two wires and complete an electric circuit.
19. DON'T open pipe caps or related devices by hands as loose black powder may be present in the threadal portion.
20. DO arrange medical and fire stand by in all cases of suspected packages.
21. DON'T ever touch a package until jarring and tumbling remotely has been accomplished due to the possibility of a sensitive vibratory switch.
22. DON'T attempt a rendering safe procedure on military munitions as the nature of these could include sensitive fuzes, directional munitions or toxic gas agents. Request military assistance.
23. DON'T be heroic as a foolish heroic act in an attack on a suspected package could cost your life. It is much easier to replace a building or damaged area than a human life. In many cases, the perpetrator relies on your heroic attack to trigger his device.
24. DON'T stereotype or try to outguess a perpetrator based on previous incidents or like devices. The device should be rendered safe with all the precautions of an unknown device until positive identification is made.
25. DON'T attempt to perform demolitions without completing an approved course of instruction under trained personnel.
26. DO use chemical protective clothing (acid resistant, glasses, etc.) in the disposal of any hazardous chemical agents such as acids, nitrates, etc.
27. DON'T transport a bomb or suspected package in the same vehicle in which you are riding. Always use a detached vehicle such as a trailer filled with sand or approved bomb carrier.
28. DON'T transport electric blasting caps, squibs or like devices in a vehicle without proper shielding or unshunted to keep out stray electricity.
29. DON'T cut any one wire of an electric circuit until the circuit is identified as the possibility of a collapsing circuit could exist.
30. DON'T remove any explosive components or separate any explosive components by hand once access is gained to a device due to the possibility of booby traps even on the smallest device. Use remote means of separation of explosive components.

292

31. DON'T wear nylon clothing while working on suspected packages due to the high static charges which could accumulate.
32. DON'T work near steam pipes, moving wheels, belts or pulleys due to the danger of static charges.
33. DON'T give information as to tools and methods to unauthorized persons as the perpetrator may use this information against you in future operations. Consider all techniques and attacks as confidential.
34. DO cooperate and co-ordinate plans with all available authorized personnel as these people are essential in any moving situation.
35. DON'T make a hasty decision, use all available references and tools. If necessary consult with other disposal experts for a decision prior to attempting a rendering safe procedure on an unknown device or package.
36. DON'T underestimate delay times or evacuation distances. It is better to over estimate the evacuation or delay times for safety reasons. A good rule of thumb is the delay time plus 50 per cent

or the evacuation distance plus 50 per cent. Time, however, is of the essence to the disposer as the bomb could explode at any time during operations.

37. DON'T underestimate the size of a suspected package as an explosive charge the size of a thimble or cigarette lighter could kill or maim nearby personnel.
38. DON'T X-ray any package where a clock work mechanism is heard to be active, as gaining access and neutralization with speed—by remote means—is essential due to the time element.
39. DON'T ever "hoose play" while working with explosives.
40. DON'T become too careless or overconfident while working with explosives—as your first mistake will usually be your last.

293

## APPENDIX D

### EXTRANEEOUS ELECTRICITY

*Courtesy E. I. Du Pont de Nemours Company, Inc.*

Firing blasting circuits electrically becomes more hazardous each year with the advent of high output radio transmitters, radar, miles and miles of added high tension lines, and static electricity in general.

Extraneous electricity means the "unwanted" electrical energy that may enter electric blasting circuits from the outside.

According to the recent edition of the *Du Pont Blaster Handbook*, the number of demolition accidents (fatalities) involving extraneous electricity has increased in the past few years.

Some forms of outside electrical energy which may cause accidents are generally:

1. Lightning; perhaps the most dangerous source.
2. Static electricity.
3. Radio frequency energy.
4. Stray currents.
5. Galvanic action.
6. Transmission lines.

Many men are under the misconception that, by merely shorting out a circuit near sources of power, they are perfectly safe. This is far from true, as you will see later in this article. There have been fatalities recorded even though the cap wires were shunted.

Let's discuss each source of stray electricity briefly.

**Lightning**—If lightning strikes a blasting circuit (shunted or not shunted), it can be taken for granted that a detonation will result. Even a near miss will probably cause detonation. There have been recorded cases of lightning strikes inducing enough current into an electrical circuit several miles away to cause a detonation; especially where a fence or high tension line runs near the shot area. Many personnel shooting during inclement weather will wait until they can physically see lightning bolts and this system is not considered good at all.

Electric caps either above ground or below ground are extremely susceptible to the high energy output of a lightning bolt. Therefore, the utmost care should be taken during, or at the approach of, a potential electrical storm.

It can be assumed that lightning has the potential of firing an elec-

294

tric cap as far as five miles away if a good conductor (fences, telephone line, etc.) runs near the blasting circuit.

It is normally assumed that thunder can be audibly heard for about seven miles. Therefore, if thunder is heard, even though the sky may be blue around you, it is time to secure electrical shooting.

A new instrument is currently under development which indicates current generated by atmospheric static and will be a valuable aid to electric blasting in the future. Du Pont may already have literature on this instrument, if you would care to write. It is the considered opinion of the Du Pont representatives that lightning represents the greatest single hazard in electric blasting.

There is a simple common sense method of minimizing this hazard, namely the use of primacord (Detcord) for electric blasting caps and



running the primacord a good distance from the shot area before printing up with a non-electric cap.

This, of course, pertains to an area where the external extraneous electricity is in doubt for one reason or another.

Recalling various field experiences, I can see that primacord or detcord was not used enough. Dangerous situations have occurred during disposal operations because personnel have "capped up" in large blow holes and proceeded to tamp heavily on top of the cap using shovels full of hot sand, white phosphorous, etc. on ranges with some degree of hazard. Priming with detcord would have eliminated these extremely dangerous procedures.

One recent instance can be cited involving a direct hit by lightning on a connected primacord hook-up. The trunk line was burned completely for a length of six feet, but no detonation resulted. This instance speaks for itself.

This does not mean that blasting should continue during an electrical storm because, in all cases, personnel should cease blasting operations during a storm of this type.

**Static Electricity** - Static electricity, grounded through an electric blasting cap, may also present a hazard and should not be underestimated during electrical shooting.

You might compare yourself to a condenser capable of retaining a charge and discharging through the cap to ground. This occurs, in certain instances, when you drop the wires to the ground, even though the cap is shunted. The voltage is high enough to break down the insulation and the shunt.

Some factors which will cause a high accumulation of static charges

295

are: dust storms, snow storms, nylon clothing, rubbing against certain materials (friction), atmospheric static, escaping steam, moving belts (conveyors), and revolving auto tires.

On at least three occasions, electric blasting caps have been detonated prematurely by the charged atmospheres built up by escaping steam.

Suggested precautions against static electricity are:

1. Ground yourself prior to handling electric caps.
2. Ground all moving equipment in the vicinity of blasting operations.
3. Discard all nylon clothing prior to electric capping.
4. Tape all connections in the blasting circuit (insulate).
5. The wiring should be kept away from rails, other wiring, machinery, or pipes which might convey electrostatic charges.
6. Use primacord again, if in doubt.

**Radio Frequency Energy** - Radio and radar transmitters can cause the premature firing of electric blasting caps even though there is no physical connection between them.

All transmitters of radio (radar) and related items, when in operation, create a field of electrical energy in the air surrounding their antennas. It has been found that, under exceptional circumstances, electric blasting caps may pick up enough of this energy to cause them to explode.

The above paragraph almost speaks for itself and during operations we cannot adequately stress the importance, because it would seem that everyone has a radio (jeeps, field sets, fire trucks, etc.).

The wires on an electric blasting cap can act just as a loop antenna, if parallel, and readily pick up radio frequency current. If your blasting circuit is laid out as indicated below, the chances of the current being induced are greater.



FIGURE 184.

One of the better procedures, if you are in doubt of near antennas, is to twist the wires thusly:



FIGURE 185.

296

An even better method is to counter reverse twist by twisting the two wires one direction and then reverse the twist in the opposite direction. In twisting the wires in this fashion; should any stray frequency be induced, it will have a tendency to dissipate rapidly because of high resistance and opposition due to the twists in the wire.

You can easily see, however, that two wires running parallel to each other and spread apart can readily pick up and transmit the current.

There are recommended tables of distances listed in the *Du Pont Blasters Handbook* for all transmitters. You might wish to read this particular chapter, if in doubt.

All available evidence indicated there is no explosion hazard in the use of an electric blasting cap at distances 7,000 feet or approximately 2,300 yards from FM or TV transmitters of maximum size today.

Certain devices are used by various concerns to detect the presence of radio frequency and one is a No. 48 pilot lamp, which will glow brightly at about .06 amperes if held in a powerful radio frequency field. This is considered a dangerous area for blasting as most electric caps will fire at approximately .25 amperes.

Transportation of caps near radio transmitters does not seem to present any great hazard as long as they are shunted and in proper containers as the coiled wire, shunts, and containers act as a shield. If in doubt, however, use a heavy metal container for transportation. Following approved distance tables and the procedures listed above should afford maximum safety.

Units should be especially watchful in and about military maneuver areas for communication men with transmitters and, while on the subject, beware of communication personnel with portable field phones (EE's) as in one instance they are known to have tied in to a blasting circuit and attempted to "ring in".

**Stray currents** - Electric current flowing from sources such as a generator, battery, transformers, etc., may travel by whatever conductors available; such as nearby pipes, wires, rails, highly metallic rock formations, etc. It is recommended to check adjacent areas prior to shooting electrically to insure that this condition does not exist.

**Galvanic action** - How many times during blasting operations have you seen a man pull the shunt from an electric cap and proceed to scrape the open ends with his pocket knife prior to shooting?

I consider this a very poor practice and if you study galvanic action, you will find that scraping two dissimilar metals in the presence of a salt solution or moisture will produce current flow. The sweat

297

on your hands plus the scraping action could possibly fire the cap.

A large commercial blasting corporation had a premature explosion when a man used an aluminum pole for tamping his electrically primed hole. The result was that the aluminum tamping pole scraped against the steel casing in an alkaline mud causing the shot to fire. Scratch one tamping pole and tampo. Object lesson: do not scrape electric cap leads with a pocket knife and use only wooden or non-metallic tamping poles.

**High Tension Wires (Transmission Lines)** - Blasting near high tension lines should be done in all cases with detonating cord as these wires present considerable hazards, other than just induced current. There is one recorded instance where a commercial blaster set up his shot near a set of high voltage lines, ran his firing reel back into the bondocks, and after a loud "Fire in the hole," got off a perfect high order shot. He then reached down to disconnect from his plunger type hell box and was immediately electrocuted. Investigation showed that the blast from the shot he was making had thrown his firing reel wires over some high tension wires (12,000 volt) out of his sight. Result: when he reached down to disconnect his blasting machine, the current took the path of least resistance through him to the ground.

The *Du Pont Blasters Handbook*, Chapter XIV, contains further information on extraneous electricity and The Institute of Makers of Explosives Pamphlet No. 20 contains a good summary of radio frequency in blasting operations.

## INDEX

## A

- Access procedure, 237
- Accidents, vii, 6, 12, 96, 168
- Aircraft bomb, 4, 158, 165, 174
- Altimeter device, 158, 165
- Amatol, 54
- Ammonia dynamite, 39
- Ammonium nitrate
  - cratering charge, 45
  - fertilizer grade, 42
  - nitrate prills, 42-44, 55
- Ammunition – general, *see* Munitions
- Analyzing bomb problem, 206
- Anti-disturbance device, 103
- Anti-tamper device, 121
- Anti-tank mine, 175
- Applied physical principles, 56-111
- Approaches, 211-212
- Arming, 96
- Armor clothing, 262-265
- Artillery shells, 172
- Atomic devices, 185-188
- Auto bomb, 131-132
- Auto bombings, 81-83

## B

- Baffle procedures, 216
- Ballistite, *see* Propellant
- Batteries, *see* Power sources
- Belleville spring (snap diaphragm), 109
- Black powder, 4, 36-37, 61
- Blasting caps
  - electric, 24-25
  - engineer special, 24-25
  - non electric, 24-25
- Blasting machines, 30-31
- Blasting supplies, 23-32
- Blasting time fuse, 28-29
- Blood gas, 179
- Bomb carriers, 258-262
- Bomb disposal area, 254-258
- Bomb squad
  - members, 246
  - organization, 216-217
  - public information, 248
  - standard operating procedures, 206-210, 247
  - training, 248

- Bomb traps, 99, 120-121, 133-135, 139-142, 144, 147-148, 152-156, 167

- Boosters, 52-53

- Box opening procedures, *see* Dearthner
- British bomb disposal, 5-6, 212-213
- Burning pit, 255-258
- Burning techniques, 231

## C

- Cannonball, 190
- Caps, *see* Blasting caps
- Carriers bomb
  - hand, 261-262
  - improvised, 258
  - vehicles, 258-264
- Cartridges dynamite, 40-41
- Categories bomb, 213-214
- Cavitation effect, 70-73
- Cavity charge, 70-73
- Chain firing, *see* Train firing
- Charges, *see* Explosives
- Chemical
  - actions, 104-105, 110
  - delay, 117
  - warfare agents, 177-181
- Chemicals, 177-181, 185
- Circuit tester, 32
- Civil war ordnance, 4, 189-200
- Clandestine devices
  - employment, 202-204
  - materials, 203-204
  - supply, 205-206

- Clockwork devices, 108, 113-117, 130, 159-164

- Clothing protective
  - armor, 262-265
  - chemical, 185

- Collapsing circuit, 147-148
- Commercial explosives, 34-45
- Composition "B," 55
- Composition (plastic) explosives, 55-56
- Concussion detonator, 130
- Conferences, 206-207
- Consultants, *see* Appendix "B"
- Containers bomb, 203-204
- Cratering charge, 45
- Crimpers cap, 30
- Cutting charges (linear), 73-74

## D

- Danger area, 238-243
- Dearthner, 217-230
- Deflagration, 15
- De-fuzing, 211-212, 216-233
- Delay devices, 6, 20, 104-105, 113-120, 130, 149, 157-164, 167
- Demolition Do's and Don'ts, *see* Appendix "C"
- Destroying explosives, *see* Explosives disposal
- Detonating cord (primacord), 26-27
- Detonation, 18

## Detonations

- definition of, 17-18
- high order, 18
- low order, 18
- sympathetic, 110-111

## Detonators, 16, 34

Disarming, *see* Render safe procedure

## Disposal

- area, 233-234, 254-255
- black powder, 36, 65
- by burning, 64
- chemicals, 64, 177
- civil war munitions 201
- detonation method, 64
- dumping at sea, 64
- dynamite, 40, 65
- explosives, 36, 38
- hazards, 233-234, *see also* Appendix "C"
- improvised explosives, 66
- methods, 64
- military explosives, 50-59, 64
- munitions, 168-169
- nitroglycerin, 47-49, 65
- small arms ammunition, 255-258

Do's and Don'ts, *see* Appendix "C"

## Dust explosives, 100, 150

## Dynamite

- ammonia, 39
- blasting gelatin, 38
- military, 39, 58
- permissible, 39
- straight, 38

## E

## Early history (bomb disposal), 3-13

## E. C. blank powder, 54

## Effects explosives

- blast, 68, 75-76, 81-83
- fougasse, 77
- misray shardin, 74
- munroe, 71-74
- on autos, 81-83
- scabbing, 78
- shrapnel, 79-80
- submitter, 79
- whistle, 81

## Electric caps, 24-25

## Electrical principles, 96-101

## Electricity

- circuits, 97-101
- extraneous, *see* Appendix "D"

## Employment devices, 202-204

## Equipment

- blasting, 23-32

common tools, 234-235  
 dearmers, 217-230  
 manufacturers, *see* Appendix "B"  
 protective, 262-265  
 special, 235-236, 258-271

Evacuation, 239-240

Evaluating bomb problem, 206-207

Evidence, 248-253

Exploders, *see* detonators

Explosions

chemical, 15  
 definition of, 14  
 mechanical, 15  
 nuclear, 15  
 types, 14-15

Explosive cord, 26-27

Explosive "D," 56

Explosive trains, 18-20

Explosives

ammonium nitrate, 12-45  
 black powder, 36-37  
 cast, 21  
 classification, 15-16  
 commercial, 35-45  
 compositions, 55-56  
 definition of, 15  
 detonating cord, 26-27  
 disposal, 63-67  
 dynamite, 38-41, 58  
 effects, 11, 68-85  
 high explosives, 16  
 history, 3-6  
 improvised, 60-63, 182-183  
 initiation of, 17  
 liquid explosives, 58, 60  
 low explosives, 15, 36-38, 50  
 main charge, 53-59  
 methods of loading, 21-22  
 military, 49-60, 63  
 nitroglycerin, 45-49  
 plastic, 56  
 primary, 51-52  
 priming, 34, 39  
 reactions, 21  
 removal procedures, 63-64  
 secondary, 16  
 sensitivity, 20-21  
 sheet explosives, 59-60  
 smokeless powder, 38  
 steaming operations, 63-64  
 transportation of, 253,  
*see also* Appendix "C"  
 trinitrotoluene (TNT), 53  
 types, 15-16

## F

Fifes bomb, 207-210

Fake bombs, 95-95

Fire devices, *see* Incendiaries

Fire greek, 84

Firecracker, 184

Firing devices, 33-34, 121-131

Firing pin, 105-109

Firing trains

basic H. E. train, 17, 19  
 basic propellant, 19  
 powder train delay, 19  
 superquick action, 19  
 time action, 19-20

Flashlight powder, *see* Photoflash powder

Fluoroscope, 266-271

Forms reporting, 208-210

Fougasse, 77

Freezing methods, 232-233

Functioning devices, *see* Initiating actions

Fuse, 28-29, 34

Fuze, 96, 110, 121-131

Fuze lighters, 32

Fuzing systems, 97-110

## G

Gagging procedures, 232

Galvanometer, 32

Gases

blood, 179  
 choking, 178  
 improvised, 181  
 nerve, 179  
 tear, 90-91, 180-181

Gelatin dynamite, *see* Dynamite

Grapple hook, 231

Greek fire, 84

Grenades

hand, 170-171, 194  
 improvised, 141, 165  
 rifle, 170-171

Guerrilla, 202

Gumrotion, 57-58

## H

Hand grenades, *see* Grenades

Hell box, 31

High order, 17-18

History

bomb disposal, 3-15  
 explosives, 3-6  
 New York bomb squad, 11-13

Hoax (fake) bombs, 95-95

Homemade bombs, 131-167

Homemade explosives, 60-63, 182

HBN-1, 57

H.E. (high explosives), *see* Explosives

Hypergolic mixtures, 182

## I

Igniters

improvised, 28, 33-34  
 manufactured, 28

Improvised explosives, 60-63, 182-183

Incendiaries

improvised, 86-90  
 manufactured, 84-85  
 mixtures, 87-88

Initiating actions

anti-photo, 109, 113  
 anti-withdrawal, 109  
 barometric, 109, 113  
 booby trapped, 109  
 collapsing type, 109  
 combinations, 109, 113, 126, 129  
 controlled, 109  
 delay, 109, 113  
 pressure, 109, 112, 122-123  
 pressure release, 109, 112, 127-128  
 pull, 109, 112, 123-125  
 tension release, 109, 128-129  
 thermal, 109, 113  
 tilt, 109, 113, 140

Initiators, 17, 109, 112-130

Instruments, *see* Tools

## L

Lacrymates, *see* Tear gas

Lead acide, 54

Lead styphnate, 52

Linear charges, 73

Liquid explosive, 60

Liquid oxygen (lox), 58

Low explosives, 15, 36-38

Low order, 17-18

Lung irritants, 178-179

## M

Mad bomber, 12, 117

Magazine, 36

Main charges, 53-59

Manuals, *see* Appendix "B"

Manufacturers of tools and explosives,  
*see* Appendix "B"

Mercury fulminate, 54

Military munitions, 168-200

Mines

anti-personnel, 175-177, 194  
 anti-tank, 175  
 improvised, 175

Misnay schardin effect, 74

Mission bomb disposal, 8, 11

Molotov cocktail, 88-90

Mouse trap, 127, 153-154

Munitions

chemical, 177-181  
 civil war, 189-200  
 classification, 169  
 military, 168-177, 189-200  
 nuclear, 185-188

Munroe effect (shape charge), 71-74

Mustard, 179

## N

Nerve gas, 179

Neutralization procedures, 47-48, 211-233

New York City bomb squad, 11-13

Nitrates, 42-45

Nitration, 45

Nitroglycerin

detection, 47

disposal, 47

handling, 46-49

manufacture, 45

neutralization, 47-49

sources, 46

Nitro-starch, 57

Non electric caps, *see* Blasting caps

Nuclear (atomic) bombs, 185-188

## O

Oil well bomb, 159

Ordnance, *see* Munitions

Organization bomb squad, 246-248

Oxides, *see* Oxidizers

Oxidizers, 182-183

## P

Package examination, 97, 215-217,  
257, 266-271

Percussion device, 17

P.E.T.N., 52

Phases of attack and disposal, 214-233

Photoelectric device, 120

Photoflash powder, 58

Phosphorous white, 180

Physics, *see* Applied physical principles

Picric acid, 57

Pipe bombs, 115-117, 137-138

Plastic bomb, *see* Plastic explosive

Plastic explosive, 55-56

Plate effect, 74

Powder blasting, 36-37

Power sources, 100-102

Preservation of evidence, 253

Pressure devices, 122

Pressure release devices, 127

Prills, *see* Ammonium nitrate

Primacord, 26-27

Primary explosives, 16, 51-52

Primers, 16, 34, 44

Priming, 34, 39

Priority, 213

Probe proof device, 121

Probing, 237

Propellants

double base, 50

single base, 50

Protection

devices, 262-265

measures, 185, 245

Proximity devices, 120

Publications, *see* Appendix "B"

Pull and tension release device,

129, 144, 177

Pyrotechnics, 90

## Q

Quickmatch, 28-29

## R

Radio device, 120

RDX, 52-53

References, *see* Appendix "B"

Render safe procedures, 47-48, 211-233

Requirements disposal area, 254-258

Rifle powder, 38

Riot control devices, *see* Chemical agents

Rockets, 172

R.S.P., *see* Render safe procedure

## S

Safe distance formula, 240-241

Safety

charts, 241, 243

clothing, 185, 262-265

distances, 238-243

formulas, 240-241

precautions, *see* Appendix "C"

Safety fuse, 28-29

Scabbing effect, 78

School (bomb disposal), 6-11

Search procedures, 243-244

Secondary high explosives, 16, 52-53

Sensitivity, *see* Explosives

Separation techniques, 232

Shaped charge, 70-73

Sheet explosive, 59-60

Shot, 192

Shotgun deaerier, 217-230

Shrapnel, 79-80

Simulators, 173, 183-184

Smokeless powder, 38

Solvents, 67

Special forces, 202

Squibs, 28

Steaming explosives, 63-64, 233

Stink bombs, 92-93, 182

Straight dynamite, 38

Submerging methods, 235

Suitcase bombs, 98, 160

Supplies, *see* Equipment

Switches, 103-104, 114-117

## T

Targets prime, 204-205

Tear gas, 90-91

Terrorists, 203

Tetryl, 52

Time blasting fuse, 28-29, 34

Time bombs, *see* Delay mechanisms

Timing disc, 108

T.N.T., *see* Trinitrotoluene

Tools, 234-236

Train firing, 18-20

Trepanning methods, 233

Triggering devices, *see* Initiating actions

Trinitrotoluene (T.N.T.), 53-54

Trip wire, 106

Tri-tongs, 231

## U

U.X.B., 6

## V

Vehicles, 258-262

Vesicants, 177-180

## W

War souvenirs, *see* Munitions

## X

"X" rays, 266-271

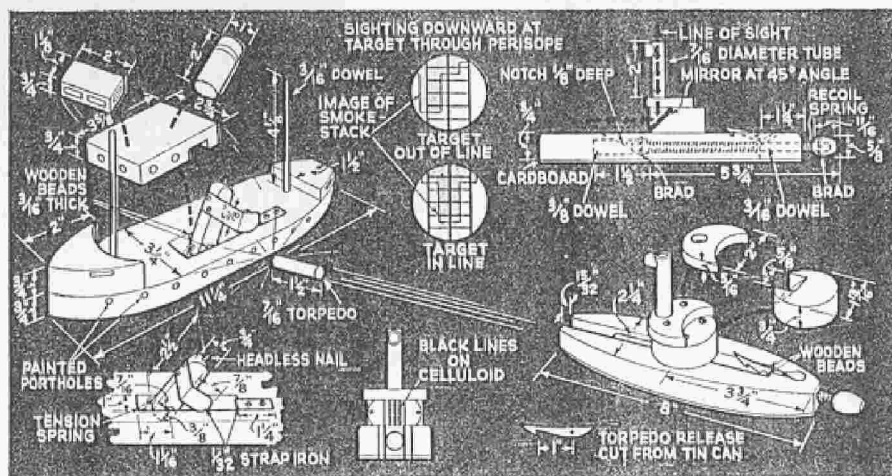

Popular Science Oct., 1943

## Sub with Periscope Sight "Explodes" Ship

**A**IM through the periscope sight of this submarine, fire a torpedo, and watch the doomed enemy freighter explode!

The torpedo tube is a slot  $15/32$ " wide, running from the bow to within  $1 1/4$ " of the stern of the submarine. A hole large enough to take a  $3/16$ " dowel loosely is drilled through the stern. Assemble the torpedo-firing mechanism from a  $3/16$ " dowel, a  $3/8$ " dowel for the torpedo ram, and a cocking knob. The torpedo-release catch pivots on a nail driven across the slot, with two wooden beads for side bearings. Cement a mirror

$9/16$ " square in a slot cut at a 45-deg. angle in the conning-tower base; cover this with a celluloid window marked as shown.

Make the freighter's superstructure from a frame of  $1/4$ " strips with a cardboard top. Use a 2" section of broomstick for the funnel. The exploding mechanism is a wooden bar, loosely pivoted on a nail and operated by a tension spring. A headless nail holds the bar under a projecting strip of metal. A second strip extends from the bar toward the port side, where it constitutes a target for the torpedo.—MYRON FLEISHMAN.



# METAL CASTING FOR MODEL MAKERS

Modern Mechanix

October, 1936

MOLDED DRIVE WHEEL AND STRAM DOME FOR "TINY TOM"

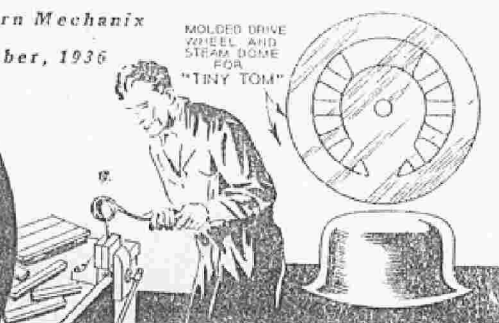
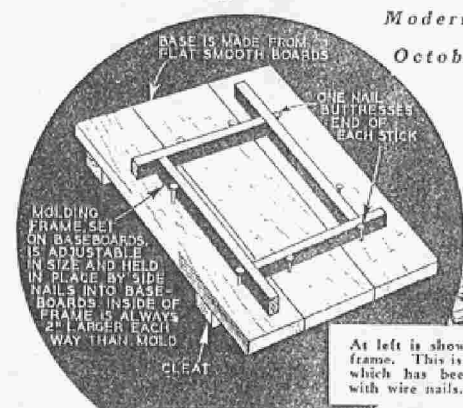

At left is shown the simplicity of the moulting frame. This is nothing more than a baseboard to which has been attached sticks held in place with wire nails. Clay is poured into this frame.

NEARLY every model maker has at some time found himself in need of a special casting which was unobtainable at the time and for that reason had to delay work on his model until the necessary parts could be secured.

Since results with castings made in plaster of Paris moulds have proved so disappointing the experienced model maker would rather have his work delayed than attempt to make castings which he knew, beforehand, would be unsatisfactory.

After much experimenting with every known material suitable for mould making ordinary cement was tried and found to be the ideal material.

The method of making cement moulds is much the same as for the more common plaster of Paris mould, but for the newcomer the method of procedure can be repeated.

The moulds are formed in a simple frame consisting of lengths of light lumber held in place to a baseboard with nails. The four sticks then being adjusted to the particular size of the casting to be copied. Soft mud is then prepared and poured into the one half of the mould and leveled off with a knife. The casting you wish to duplicate, for example a model locomotive wheel, is carefully

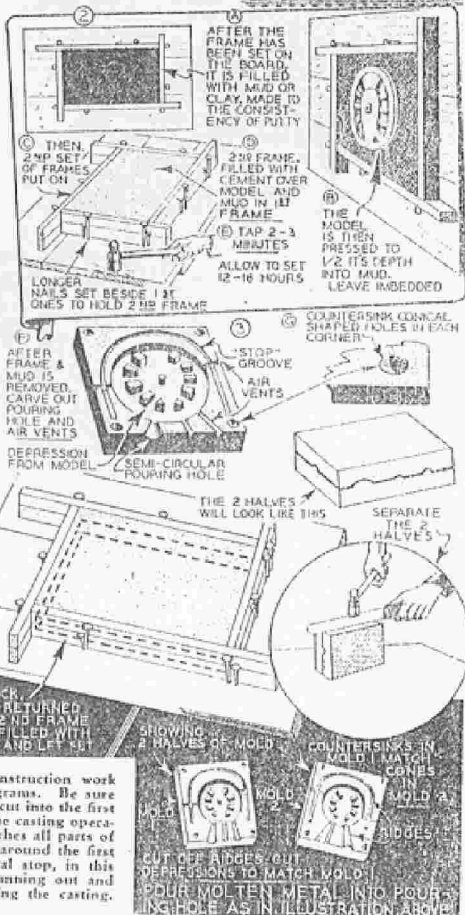

The stages of the mould construction work are outlined in the above diagrams. Be sure that sufficient vents have been cut into the first cement mould so that during the casting operation the lead or aluminum reaches all parts of the mould. A groove carved around the first cement mould provides a metal stop, in this way preventing metal from running out and burning the model maker doing the casting.

oiled and then pressed half way into the clay after which it is removed. With this work completed constructed another wood frame and install it over the top of the first. Now oil the surface of the clay impression with any light lubricant being sure that all parts of impression are covered. The first cement mould is now ready for pouring. Mix the concrete with nothing but water until it is in a mush-like state. Now allow the cement to stand for fifteen or twenty minutes then mix again and pour into the mould. After pouring the cement tap the baseboard with a hammer so that all air pockets are punctured and the cement settles in all parts of the mould then allow the cement to set for 12 hours.

The hardened mould is removed from the frame and the clay washed away so that all that remains is a clean cement half mould. Take the cement mould and carve out pouring and vent holes with

a sharp knife or chisel and also the semi-circular pouring holes. Holes countersunk in each corner of the mould serve as locks and hold completed moulds in place.

To cast the other half of the mould grease the surface of the completed concrete section and place the original casting in the recess. Replace the wooden frame and pour in a top layer of concrete. Allow this to set for 12 hours, remove the frame and pry the moulds apart with a knife. After cleaning the section the cement mould is ready for use.

Aluminum, lead or any soft alloy can be cast in this type of mould. Placed in a small workshop vise the mould will permit the metal to be easily poured. To increase the strength of the moulds allow them to soak for a few days in water.

It is possible to make over a hundred castings from a single mould treated in this manner.

# METAL CASTING IN ALUMINUM AND BRONZE

Modern Mechanics, Dec., 1936

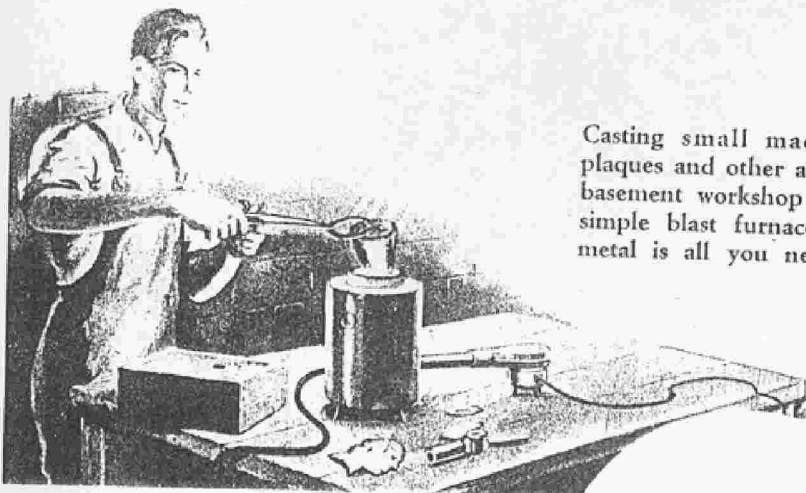

Casting small machine parts, plaques and other articles in the basement workshop is easy. A simple blast furnace and scrap metal is all you need to start.

**T**HOUGH too difficult for shop production the interesting art of metal casting has been passed up by many shopmen and home craftsmen who did not realize that this craft was really simple after its procedure had been studied. Using any of the popular soft metals and plaster of Paris wall plaques such as sold in ten-cent stores anyone, with

a little practice, can make perfect reproductions of these articles in bronze or aluminum. The finished articles make attractive gifts as well as decorations for use in your own home. Small parts for models, machine bushings and light hardware can also be duplicated in the home workshop at a fraction of their usual cost with this apparatus.



A miniature blast furnace well suited for home shop use can be purchased for less than twenty dollars. Operated by a light electric powered blower and a gas flame the furnace will handle up to six cubic inches of molten metal. It is unnecessary to use new metal for casting light articles since scrap metal melted over is just as good and costs only about ten cents a pound from junk dealers.

After completing your furnace set-up preparation of the molds can be undertaken. These are made from very fine sand which has been screened to remove all lumps, then

moistened with water and mixed with a trowel until when squeezed in the fingers the fingerprints show in the sand. Pack the moist sand into the flask taking care that the sand is packed well in all corners. The flask is a pair of box-like frames which rest one on top of the other with small dowel pins provided so that they register properly. Grooves cut inside the frame prevent the sand from dropping out once it has been packed in. The accompanying illustrations show the simplicity of their construction.

With the sand packed in one frame or flask the pattern is ready for impression. In this



Before making the sand mold, carefully sift the finest sand obtainable through a screen as shown above, then moisten it and pack it firmly into the frame or flask in the manner as described at right. Sand should be moist--not wet.

After packing the sand in the frame press the plaster plaque in place and powder both it and surrounding sand with fine powdered graphite.

Completing the graphite powdering, place the upper frame over lower and pack it with sand. Frames are carefully separated and plaque removed as shown at right.

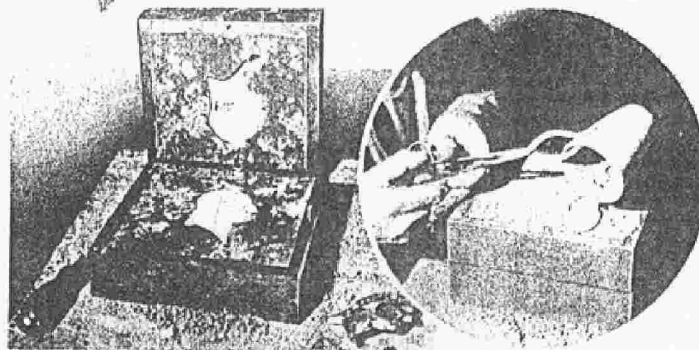

Holding the crucible with forceps pour the molten metal in one continuous stream into mold as shown above until it overflows.

case a plaque of George Washington was selected and placed face up in the center of the sand mold. Next press the plaque firmly into the sand until all edges touch evenly. Sprinkle powdered graphite or talcum powder over both the surface of the sand and plaster plaque wiping off carefully all surplus.

The top half of the frame or flask is then put into place and sand sprinkled lightly over the graphited surface by passing it through a screen. After the plaque and sand surrounding it has been covered to a depth of one inch or so pack it down carefully with a trowel then add more sand, packing it as you go, until the mold is full. Be sure to provide a hole in the top half of your mold to allow for pouring the metal. A three-quarter inch dowel stick will allow for this.

After the top half has been well packed remove it from the bottom half of the frame and lift out the plaster plaque. Dust off all loose particles, clean the pouring hole and reassemble the frame and the metal pouring proceeds.

By this time the metal should be in a molten state. Lift off the furnace coverings with the forceps and with a stick remove the slag which

probably has formed on top of the liquid metal. The metal, no matter which kind you are using, should be no hotter than is necessary to cause easy flowing. Lift out the crucible with the forceps and pour the metal into the well. Don't let the pouring stop or the stream of metal break. Continue pouring until the weight of the metal has forced the liquid into all parts of the mold and builds up above the sand level. If some metal remains in the flask it should be poured into a depression made in the sand. When metal is left in a crucible and then melted, the expansion will often crack the container.

Don't disturb the casting until the exposed metal is hard. Then carefully dig out the figure from the sand. Quite often there is as much metal in the well casting and the surplus on top as was required for the casting. This can be used next time. Cut off the waste with a hack saw and then file smooth to finish.

If the metal is quite hard, a steel wire wheel can be used to brighten the casting. If of aluminum, pewter or any of the softer metals, only a cloth buffing wheel should be used. However, very fine pumice or emery and beeswax rubbed into the edge of the cloth buffer will speed up the polishing. And usually, even when the wire wheel is used, the final rubbing should be done with the cloth buffing wheel.

No such casting is complete without a suitable plaque. If you have a shaper or shaper bits and drill press, the oval type is usually the most

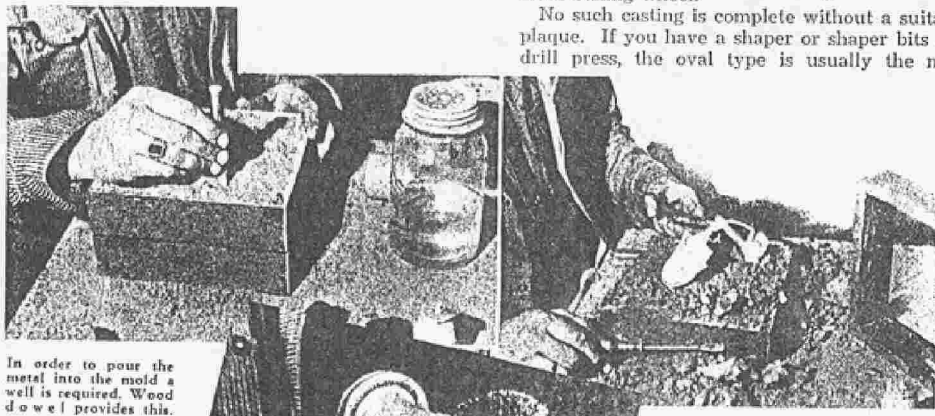

In order to pour the metal into the mold a well is required. Wood dowel provides this.

After the metal has been allowed to cool, the sand mold is broken apart and the rough casting removed. Above is shown the casting before surplus metal was cut off. This is done with a hack saw and several sizes of files.

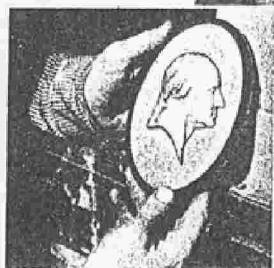

After the casting has hardened it is removed, rough parts filed down and the surface is polished on a buffing wheel.

pleasing. However, with only a lathe you can make a lovely round plaque or, lacking this, you can simply saw out a square or rectangle of wood, bevel the edges and finish.

If you have access to cheap scrap copper, zinc, lead and tin you have the facilities for making almost any alloy you might wish. One of these small blast furnaces will make this possible. Perhaps our most common alloy—solder—is simply tin and lead melted together. What is known as 50-50 solder is, as its name implies, 50% tin and 50%

lead. This is a soft solder. A harder solder consists of 2 parts tin to 1 part lead. Having scrap tin and lead available you can melt them down and cast your own solder in convenient bars. Before passing solder, it is perhaps interesting to note that, by themselves, tin melts at 512 degrees F. and lead at 620 degrees F. However, when combined in equal parts as for soft solder, the melting point of the alloy is only 365 degrees F.

Many will stoutly maintain that brass is the most common alloy. Perhaps it is, at least in application and usefulness. Common brass is made by melting copper 85.0, zinc 5.0 and tin 10.0. Here are some other combinations and their percentages:

Kind of metal	Copper, per cent	Tin per cent	Zinc per cent	Other metals per cent
Aluminum bronze	88. to 95.			5. to 12. aluminum 0.05 phosphorus
Phosphor bronze	98.75	1.2		70.0 aluminum
Aluminum brass			30.0	
Tough brass	55.0	0.5	44.5	
Yellow brass	66.66		33.33	
White brass	10.0	10.0	80.0	
Red brass	82.0		18.0	
Church Bell metal	78.0	22.0		
Bronze for medals	93.0	7.0		
Gun metal	91.0	9.0		
Coinage bronze	95.0	4.0	1.0	
Pincheck (imit. jewelry)	90.0-85.0		15.0-10.0	
Pewter	10.0	90.0		25.0 lead
Inferior pewter		75.0		
Halbritt (one of many)	3.7	88.9		7.4 antimony
Type metal		20.0		20.0 antimony
Stereotype metal	2.0	10.0		60.0 lead 70.0 lead 18.0 antimony

The range of metal alloys given in the above table should enable one to work out just about whatever he wants in the way of special metal for casting or turning. Pewter is so easily made that coupled with its non-tarnishing characteristic, and ever voguish appeal, should be popular for turnings especially. For casting of medals and other small articles however, aluminum bronze is hard to beat.

Here is another table—this one giving the melting points of a number of metals and alloys:

Metal	Degrees F.	Metal	Degrees F.
Tin	512	Nickel	2646
Lead	620	Cast steel	2800
Zinc	755	Solder	
Aluminum	1300	2 Tin, 1 Lead	365
Silver	1760	1 Tin, 1 Lead	401
Gold	1947	Aluminum bronze	1700
Copper	1981	Brass	1800
Malleable iron	2100	Bronze	1900
Gray iron	2192	Phosphor Bronze	2000

While not as accurate as the cone method for determining degrees of heat (no thermometer can withstand high temperatures) the color method is worth knowing—and remembering. Here is the range of gradations of color of heated metal as experts know them:

Observed Color	Degrees F.	Observed Color	Degrees F.
First red visible in the dark	878	Orange	1650
Dark red	1000	Light orange	1725
Dark cherry red	1175	Yellow	1850
Cherry red	1375	Light yellow	1975
Light cherry red	1550	White	2100

# Cast Your Own Pewter



The bud vase at left was cast with an opening all the way through to facilitate cleaning.

Mechanics Illustrated Sept., 1947

**Instead of envying the owners of unusual pewter, why not try your hand at casting? It's not hard.**

**BY DICK HUTCHINSON**

**S**AY "casting" to most people and they immediately think of intricate molds and fiery crucibles. But, did you ever stop to think that small boys since time immemorial have been doing their own casting—of lead soldiers?

Casting small pieces in pewter is just as simple as casting in lead or type metal, and may be carried out in the same way right in your home workshop. Pewter casts as

easily as lead or type metal. It produces beautiful, sharp castings, and finishes just like silver.

Lead, of course, casts very easily, but will shrink slightly in cooling, resulting in rounded corners. Type metal, on the other hand, expands slightly and is, therefore, excellent for fine detail.

Most home casting is done with plaster of Paris molds. If only two or three castings are to be made from the mold, it is excellent, however, after two or three "casts" the plaster mold will burn out and crumble. If, however, the mold is made of 1 part Portland cement to 3 parts plaster of Paris

core cannot be removed, make the core first as illustrated, by rolling and gluing paper into the desired shape. Fill the core with a mixture of fine sand and glue and let dry. Shellac the outside, then make the pattern by rolling and gluing paper to the proper thickness around the core. Then coat the outside of this with shellac. The handle is made from a length of copper wire bent to shape.

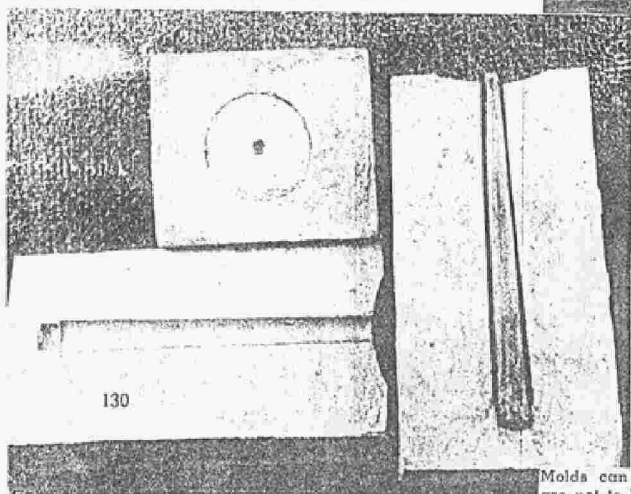

Above: Pouring the molten pewter into the mold for the vase. Best molds are made of a mixture of plaster of Paris and cement.

Left: The mold for the bud vase. Note how the core is set in place. After the mold is dry, each side is shellacked before casting.

and dried very slowly, it will produce a mold that is very durable and from which a great many castings may be made before the mold deteriorates.

For making castings such as the small mug shown, where the inside is of a larger diameter at the bottom, and an ordinary

Molds can be made of plaster of Paris if they are not to be used more than two or three times. After this they tend to burn out and crumble. You can cast with lead if you like but this material tends to shrink slightly after cooling yielding round corners. Type metal is good for fine detail.

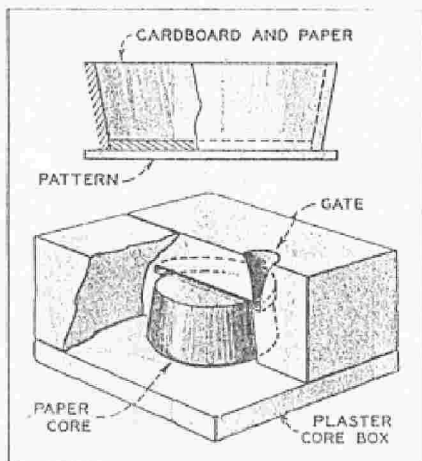
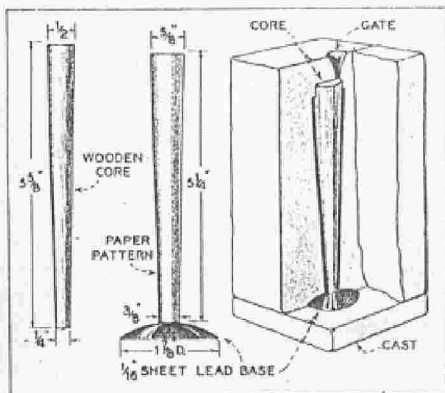

Make a small box of wood or cardboard. Mix the cement and plaster of Paris to the consistency of a thick batter and pour the box half full. Then press the pattern half way down into the paster and let set. Remove the pattern and coat the mold with shellac. Replace the pattern and coat the surface of the mold with motor oil; then fill the box with the cement. Let set, then remove the pattern and

Photograph at right shows the bud vase casting being removed from its mold. Pewter can be polished on a buffing wheel to produce a sheen that will rival silver. Pewter, if you're still interested, is an alloy of tin hardened with antimony. Cheaper varieties may contain considerable lead.

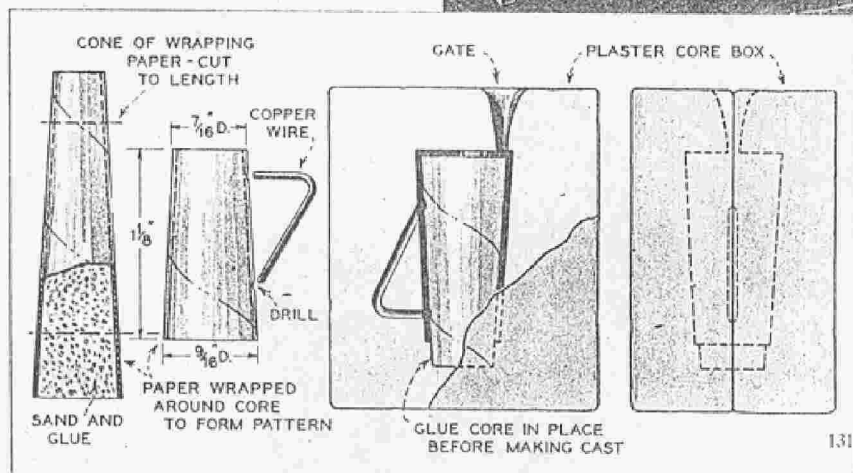
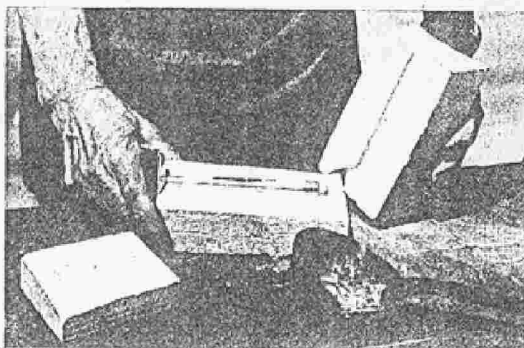

with a pocket knife carve the gate through which the metal is poured.

When the mold is thoroughly dry, coat each side with shellac. Now you are ready for the cast. Glue the core in as shown. Bind the mold together with rubber bands. In melting the pewter, it should be placed in a lead ladle and heated. Not just until it is melted, but until it is thin enough so that it will run like water. It is advisable to heat the mold before casting, so that the metal will not cool before it fills every part of the mold evenly.

The mold should be absolutely dry before attempting to make a casting. Any moisture in the mold will create steam and cause the metal to boil and run out. Pour the pewter into the mold through the gate, and let set until hard. This will require only a few moments.

Remove the casting. Cut off the gate metal. Remove burrs, and file or grind smooth. To remove the core, place the piece in a pan of boiling water. This softens the glue and the core will then dissolve.

After the piece has been smoothed with fine emery paper, polish on a buffing wheel.

The drawings illustrate how the molds are made. Casting odd pieces in pewter is one of the most fascinating hobbies that anyone could imagine and a collection of these pieces is really something to admire. •

## AMERICA IN 1950

### IF THE AXIS WINS . . .

. . . you'll still be in a uniform, whether you're a man, woman or child. And your immediate superior won't be a hard-boiled American sergeant—he'll be a Nazi *ganleiter*, a storm trooper or a swaggering Japanese militarist.

### IF AMERICA WINS . . .

. . . you can be certain that your loved ones now in uniform will be back with you, working at their old jobs and enjoying life as only Americans can. And to get that form of life, you *have* to support your government now, by purchasing your share of War Bonds!

# METAL CASTINGS

**I**NTRICATE castings of small objects such as wheels, model parts, statues and busts can be made by this method, which employs a pattern of modeling wax. The process is such that usually it is not necessary to part the pattern. One variation of this general method makes it possible for you to purchase inexpensive novelty china statuettes and then duplicate them in every detail with soft metals such as brass, aluminum, bronze, type metal, pewter or lead. Examples are shown in Fig. 3.

Now to get into the process. The one method which is most widely applicable uses an original pattern made of wax. As an example, take the wheel shown in the center detail of Fig. 2. Making this pattern of modeling wax is really very easy as the wax can be softened and molded into most any shape, and then trimmed to the exact size wanted, as in Fig. 4. The finished pattern should be mounted on a plaster-of-paris base made as shown in the upper detail, Fig. 2. Then a form such as a tin can with the ends knocked out, is placed around it as in the lower detail. To provide for pouring the metal, rods of wax

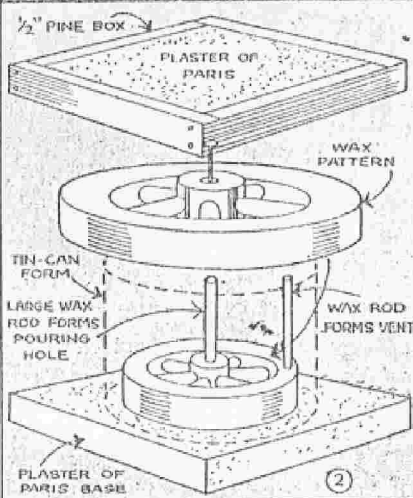

CASTINGS MADE WITHOUT PARTING

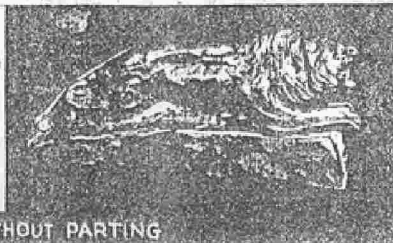





are softened and stuck on the highest part of the model, Figs. 2 and 6. These should extend higher than the metal form and one should be large enough to provide a passage for pouring the molten metal; the others serve only to let air out of the form. The wax pattern must be fastened down so that it can not move when the plaster is poured over it.

A thin mixture of plaster of paris is made by taking enough cold water in a large pail to fill the form, and slowly dropping in plaster of paris until some of the latter comes to the surface and floats, Fig. 5. Then the mixture is stirred well and poured into the form, as shown in Fig. 9. When the plaster is dry, the wax pattern is melted out as shown in Fig. 8, by standing the mold over a gas flame, with the vents down, and with a pan provided to catch the melted wax. Care must be taken that the wax does not catch fire. The mouth of the pouring hole should be enlarged so that it is funnel shaped.

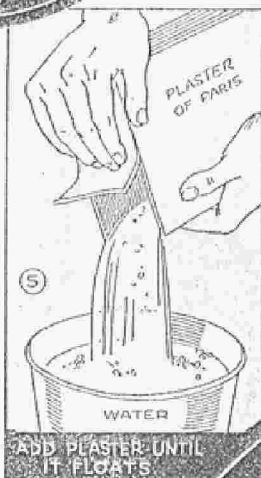

The mold must be thoroughly heated to drive out the last trace of moisture. The metal should be melted down in a crucible placed in a forge or a gas furnace. Lead, type metal, pewter, etc., may be melted in an iron pot in a forge, Fig. 16. The crucible should be handled with tongs similar to those shown in Fig. 8, and the metal poured as in Fig. 7. All pouring of molten metal should be done over dry sand. Excess metal must not be allowed to "freeze" in the crucible. After the metal has solidified in the mold, the form is removed and the plaster broken away by plunging the hot mold into a tank of cold water. With large molds, the plaster should be broken off. The pouring riser and vent prints on the casting may be sawed away and the surface dressed with a file or grinder.

Another method must be used where there is already a model to work from and where a single duplicate of any article is needed, or when a broken casting must be replaced. The broken



parts can be fastened together temporarily and used as a model for a new casting. Also duplicates of antique or unusual parts can be made from the original without in any way injuring it. The model is first set in position on a flat board, as shown in Fig. 10. In order to keep it in this position and to return it to the same place, spotting pins or small brads with their heads cut off can be driven into the base and pressed down into the model. The model next should be covered with two or three layers of wet newspaper, and then a layer of modeling clay, at least  $\frac{1}{4}$  in. thick as in Fig. 11. The outside of this should be coated with paraffin oil or grease. A wood flask, spotted with pins, Fig. 12, is placed around the model to retain the plaster. The inside of the flask should be greased thoroughly. The plaster mold can be in one piece if the draft or taper of the model runs all in one direction from the base as in Fig. 14. If not, the mold will have to be parted approximately along the center line of the model by imbedding a light length of piano wire in the clay along the desired line and drawing it out when the plaster has partly set.

When the plaster has set, the mold is removed

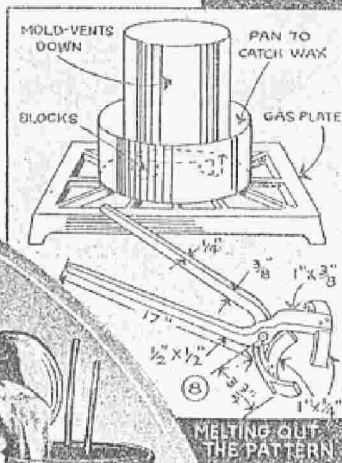

carefully from the clay. All the clay and the wet newspaper are now removed from the model and plaster mold. A pouring hole is drilled through the mold at the top, using a knife and working from the inside. The mold is then set back in position around the model as shown in Fig. 15. Both the model and the plaster mold should be coated with oil. Small vent holes must be drilled any point where the air is

likely to be trapped. Next, soak cabinetmaker's white glue in sufficient cold water for fifteen minutes to swell the glue completely. Excess water is then poured off and the swollen glue is placed in a water-jacketed glue pot or a double boiler, and melted. When melted, it is poured into the mold

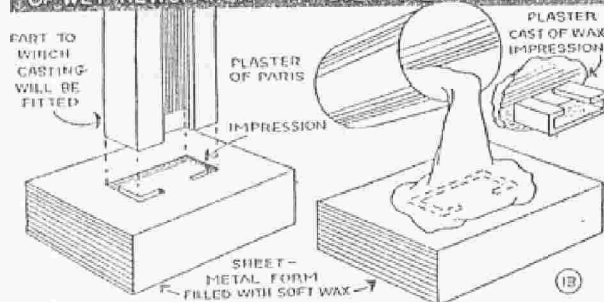
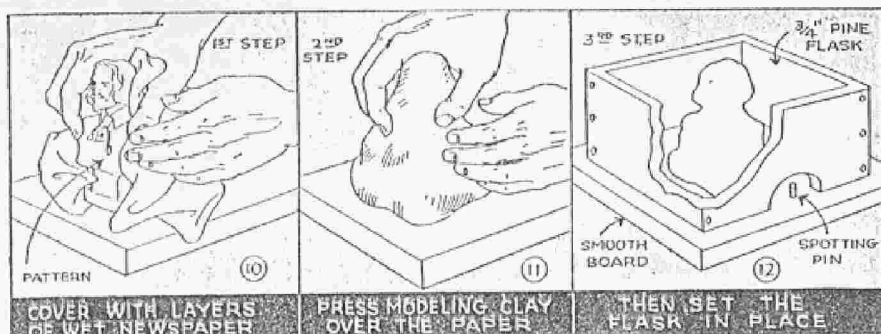

until the space between the model and the plaster is filled. Give this plenty of time to set. The plaster case is then removed and the glue mold carefully split and skinned off. The model is no longer needed. Now cut a pouring hole at the top of the glue mold, as was done with the plaster case, and put the glue mold and the plaster case together and in place on the board. Vents should be provided if necessary. If the mold is in two parts it must be clamped together. Melt modeling wax and fill the glue mold. When the wax has set, you have a wax duplicate of the original model, and the casting is made from the wax pattern as previously described.

Frequently it is desired to make a casting, one side of which shall accurately fit a contoured surface, which may be cast, stamped, or formed in some other way. Fig. 13 shows one way of doing this. This method is particularly useful when it is required to cast a mounting bracket or ornament to fit a formed section, beam, or machine part exactly. A wax impression of the contour which is to be matched is made first and then a plaster cast of this impression which gives a positive dupli-

cate of the original part. Working from this, a wax model of the desired casting can be made.

A small blast furnace which will melt a 10 or 15-lb. charge of brass, aluminum, or any other metal melting under 2000° F. can be built from a 5-gal. oil can with the top cut away, Figs. 17 and 18. Two holes are drilled and reamed for  $\frac{3}{8}$ -in. pipe nipples in opposite sides,  $3\frac{1}{4}$  in. from the bottom. The heat-resistant lining is built up from ganister, a mixture of equal parts of fire clay and pulverized firebrick, moistened with water and worked up to the consistency of heavy plaster. Scraps of firebrick are added as filler and to increase the strength. The bottom of the can is covered with 1 in. of ganister, which is packed down by ramming with a stick. Four pieces of firebrick, each  $4\frac{1}{2}$  in. long and  $3\frac{1}{2}$  in. wide, are pressed down into the ganister, and another piece is placed in the center to support the crucible, Fig. 18. The space between these bricks is packed with ganister to within 1 in. of the top of the bricks. Two pieces of  $\frac{3}{8}$ -in. gas pipe are inserted through the burner holes to form openings for the burner pipes. A smooth sheet-metal form 8 in. in diameter and free from dents is now set in the can, centered and propped in place. The space between the outside can and the center form is now filled with ganister and pieces of firebrick. When the wall has set sufficiently to support its own weight, which will be in about 12 hours, the center form and the  $\frac{3}{8}$ -in.

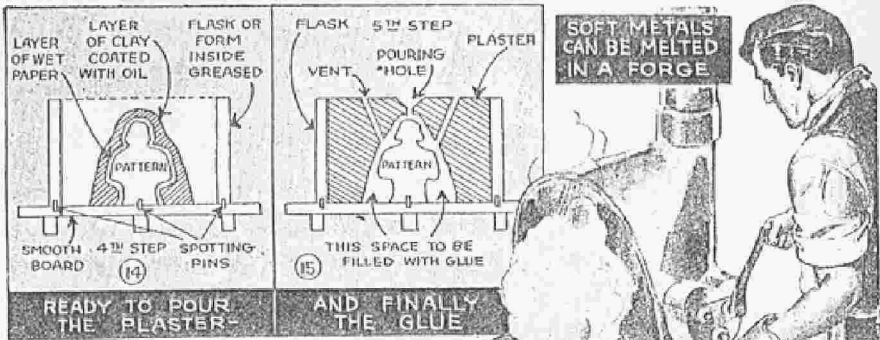

pipes should be removed and the furnace left to dry in the air for about three days. The burner assembly shown in Fig. 17 is built from 3/8-in. pipe and fittings; connections to the gas and air supplies are made with 5/8-in. garden hose, or better with pipe fittings and unions. The air can be supplied with a vacuum cleaner as shown, the adapters A and B being turned from hardwood. After testing the pipes for leaks, the final drying of the furnace is accomplished by operating it without an air blast for half an hour or more. The furnace is always lighted and adjusted according to the following sequence: (1) drop a piece of burning paper inside the furnace; (2) turn on the gas; (3) start the air blast and adjust gas flow to the minimum which will give good combustion. This is indicated by long tongues of almost colorless blue flame, forming an intense, whirling flame in the furnace. In shutting off the furnace, always turn off the air first, then the gas. Cracks that form in the refractory lining are filled with a putty made of fire clay and water. To melt a charge, start the furnace and insert the crucible of metal with tongs. Borax is added to dissolve any dross that forms. This should be skimmed off before pouring. To inspect the charge, lift the asbestos cover with tongs and observe the contents through colored poggles. The best crucibles to use are graphite. A stand for the furnace is shown in Fig. 19.

Back in Fig. 1 is shown an inexpensive gas furnace which is now on the market. In general construction it is similar to the furnace just described, but is fitted with a special mixing burner and an electric blower. It is supplied in several sizes, all suitable for home shop use.

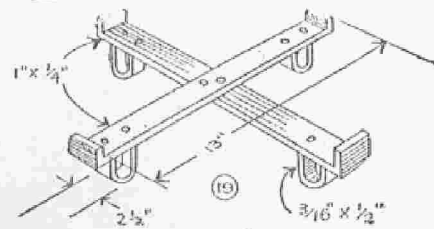
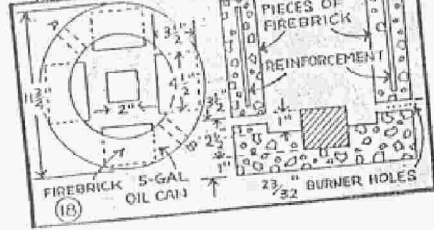
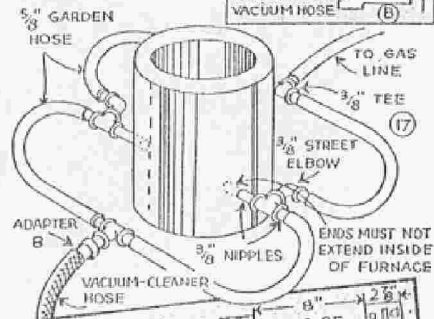

## METAL CASTINGS

### Molds to Cast Small Metal Objects Are Made With Cement

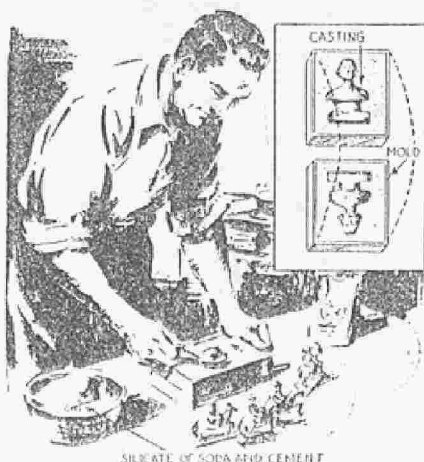

In casting small objects from soft metals, I have found that portland cement mixed with silicate of soda provides good molds for the work. Enough soda is used to make a mixture of the right consistency for easy shaping of the mold. Such molds stand up well for casting toys, small statuary, etc. I have also used them for casting aluminum and zinc as well as brass.

### Casting-Mold Corners Rounded With Ball-End Tool

When making aluminum castings, I find that a very neat job can be done by rounding the corners of the mold with wood putty, which I spread evenly and smoothly with a ball-end tool. This is made by soldering or brazing a  $\frac{3}{8}$ -in. steel ball to one end of a small steel rod as shown in the drawing. If the tool is moved over the plastic with a twirling motion, you will get a uniform job.

### Eliminating Pinholes in Castings

In making steel dies with a steel core in order to mold solid-babbitt bearings, there was only .015 in. allowance inside and outside for finishing. When finishing the cast-

ings, we found they were full of small pinholes just under the surface. To get rid of them both the steel die and core were first heated and then the inside of the die and the outside of the core painted with blue clay, pulverized very fine and mixed with water to a thin paste. This is applied with a small brush to the hot die and core quickly, as it will dry as soon as it touches the hot steel. This paint allows the gases to escape from the metal and eliminates all the holes.

### Stereotype Metal Makes Good Casting Molds

Amateurs who have a limited supply of equipment will find stereotype metal good for making casting molds, as it has a low melting temperature, which is easily reached with ordinary heating methods. Wooden patterns can be used without burning, if the metal is not cast in too large quantities. Care should be taken to avoid getting water into the molten metal, which would cause it to splatter. The correct casting temperature has been reached when a piece of paper inserted into the molten mass turns a rich brown. Stereotype metal is fairly strong and will not crack under sharp blows. It can usually be obtained from small newspaper offices.

### Castings Supported on Steel Wool While Welding Them

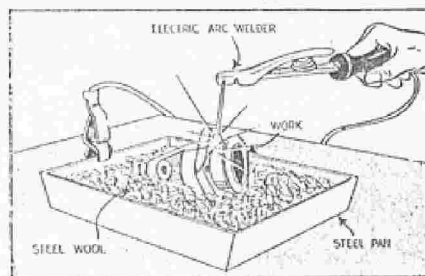

Sometimes when using an electric welding outfit on work that is irregular in shape it is difficult to attach the ground clamp to it. Try making a nest of steel wool in an iron or steel pan to hold the work and fasten the ground clamp to one edge of the pan. The steel wool assures a good electrical contact with the work.

# Physical and Chemical Tricks!



MECHANICS and HANDICRAFT Dec., 1936

## Poisonous Water

**O**BTAIN a small piece of sheet lead or lead pipe and scrape the surface of it until it is bright and shiny. Place this metal into a beaker containing distilled water and allow it to remain for several hours (or over night). To determine whether or not the water has become poisoned, due to the presence of lead, make the following test: Allow some fresh hydrogen sulphide gas to bubble through the water (the hydrogen sulphide gas is made by adding strong hydrochloric acid to solid ferrous sulphide. This gas has an offensive odor and should be handled near an open window or at a hood). The water, if poisoned by lead, will turn a brownish black color.

## Liquid Solid Magic

**P**REPARE a saturated solution of sodium thio-sulphate or "hypo" by adding numerous crystals to a cold-



A spectacular experiment in rapid crystallization.

water solution. When it will take no more crystals, heat the solution gently and now add more crystals until it again will take no more. After allowing it to cool, drop in a crystal of "hypo," and the solution will solidify.

(Principle: When a super-saturated solution of a crystalline substance is disturbed, rapid crystallization takes place.)

## Home Made Sedative

**T**HIS experiment should be done at an open window or under a hood. Add some concentrated hydrochloric acid to some chloride of lime. Allow the greenish-yellow gas to pass into a flask containing about one

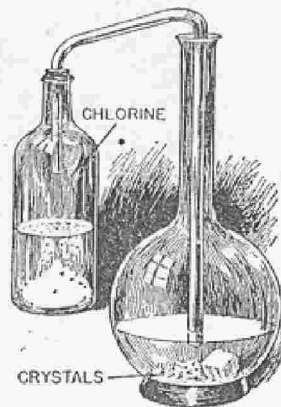

The production of chloral hydrate, in the laboratory, is indicated in this diagram.

ounce of alcohol and an ice cube. An oily substance is produced (chloral) which, when mixed with water, produces, in a short period, a solid crystalline substance, which is a useful medicine, acting as a sedative. This should be used *only* under the direction of a physician, as it is dangerous.

(Principle: When anhydrous chlorine gas comes in contact with alcohol, chloral is formed, which, with water, forms a solid known as "chloral hydrate.")

# Carbide Mortar Makes Big Bang

Popular Science June, 1955

By Evan Wright

**T**HIS little mortar can be heard for blocks, and a young artilleryman can fire it from dawn to dusk on a quarter's worth of calcium carbide. The chemical generates acetylene gas for harmlessly small explosions behind a soft rubber ball.

The mortar barrel is a large fruit-juice can (4½" by 7"). To bring the muzzle down to a snug fit for a 4" ball, cut four equally spaced slots a couple of inches long in the front, lap the edges slightly, and solder the seams. Quarter-inch nuts, soldered to the can sides, act as trunnions. A thin ⅜"-20 nut, soldered over a hole in the bottom of the can, forms a fitting for the detonator—a model-engine spark plug.

The mortar base is made from ¾" plywood. Besides supporting the barrel, it houses a small ignition system, consisting of two flashlight batteries, a model-airplane spark coil, a 20-microfarad radio condenser and a doorbell button.

When the button is pushed down, the condenser takes up a small charge from



the batteries. This charge surges through the coil when the button is released, producing a hot spark at the plug.

To fire the mortar, tip up the barrel at a 45° angle and drop in two rice-size pieces of carbide (adding more will make the explosion no bigger). Add a teaspoon of water, jam the ball in the muzzle, and let the gas generate for half a minute. Push down the button momentarily, then release it, and—boom. There goes that ball!

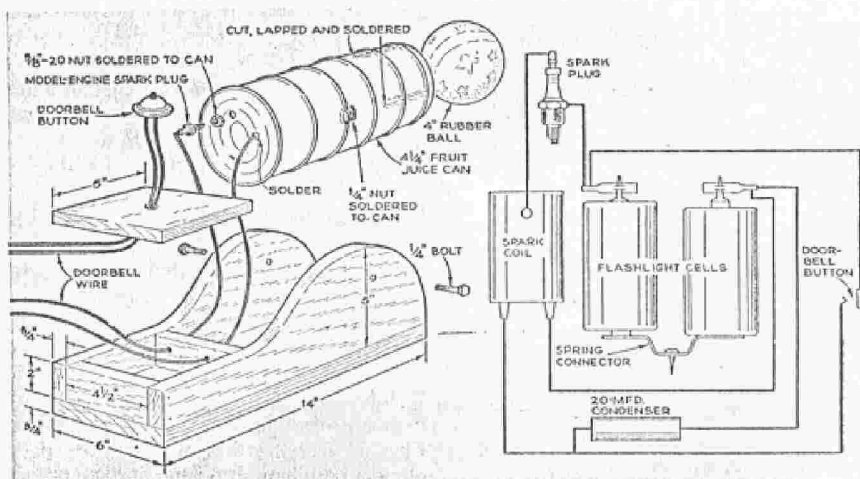



# Harmless Steam Cannon Shoots Ball Bearings

Modern Mechanix Oct., 1936

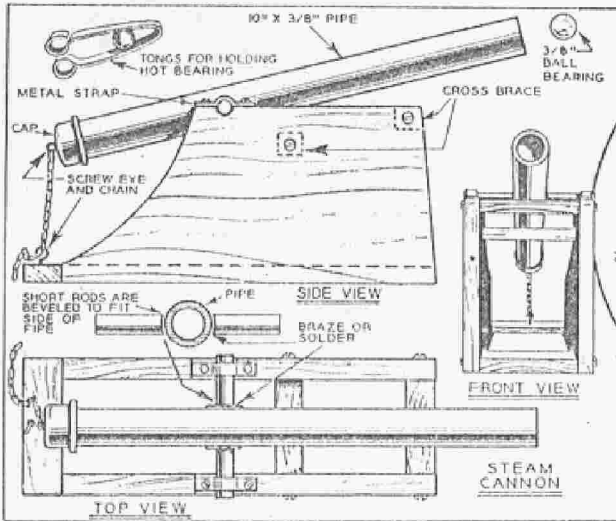

Costing practically nothing to construct this novel steam cannon shoots steel ball bearing in a most realistic manner. The gun barrel is merely a length of 3/8-inch iron or brass pipe.

**T**HIS tiny steam cannon operating in much the same manner as Archimedes famous cannon will prove an interesting project for the workshop. The cannon works in a very realistic manner simply by heating 3/8-inch steel bearings until they are red hot then dropping into the barrel of the cannon in which a small quantity of water has been poured. The hot bearing striking the water converts it into steam which immediately expands and shoots the bearing out of the cannon.

To build the cannon secure a 10-inch length of 3/8-inch pipe with a smooth inside surface. Tap one end and attach a cap and at the same time braze or solder two rods to the sides of the cannon barrel for swinging in the wooden cradle. The cradle is constructed from scrap stock with small cross braces inserted to add to the rigidity. Cut recesses in the top of the cradle to allow for the barrel axel rods then fasten the barrel in place by fastening metal straps over the rods as indicated in the pictorial diagrams. A short length of chain attached to the cap end of the cannon barrel permits adjustment of the barrel when firing the cannon.

For ammunition secure a number of 3/8-inch steel ball bearings then place over a wire grill and heat until red hot. A small amount of water is poured into the cannon followed by the hot bearing. The steam pressure will shoot the pellet high into the air.

## Safe "Javelin" for Young Boys Has Padded Head

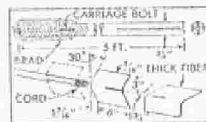

Nestly balanced and provided with a padded head, this javelin is safe for young boys, and it can be thrown accurately at targets some distance away. The shaft is about 5 ft. long and 3/4 in. in dia. Notch one end for the fiber "feathers" that stabilize flight, and insert a carriage bolt into the other end to provide sufficient weight for the head. The padding covering the bolt is held with brads.



# MODEL SIEGE GUN

A handsome model cannon that actually fires a .22 caliber blank cartridge—Use as distinctive ornament in the den, or as a boat club accessory.

by Edward F. Waldron

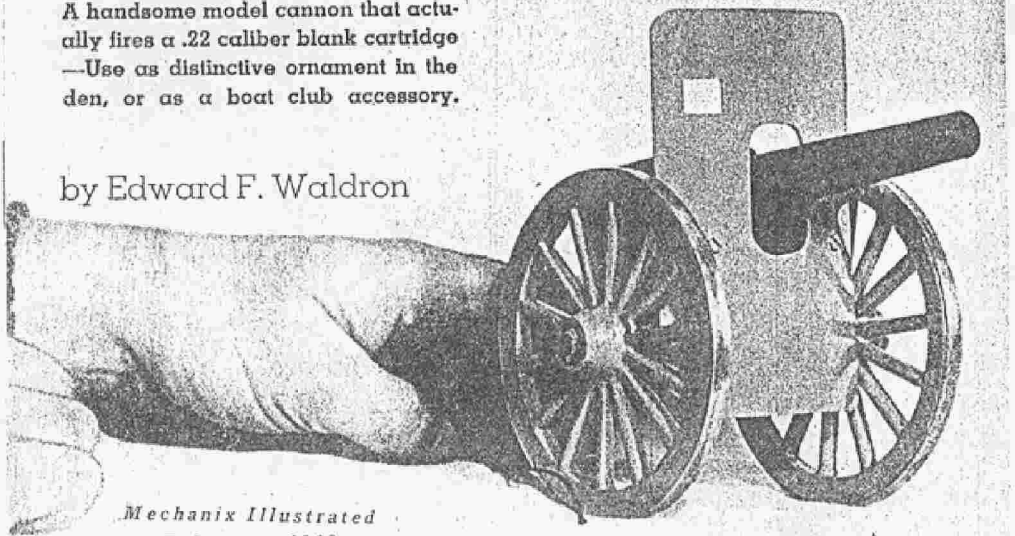

*Mechanix Illustrated*  
February, 1943

**T**HIS cannon is really a series of exercises for you to try out your ability with a hack saw, jewelers' saw, taps and dies, your metal lathe, and finally your ability as a wheelwright in making a pair of real wooden spoked wheels with metal tires.

First let us begin with the barrel. It is bored for a .22 caliber blank cartridge. In order that it may be purely a blank cartridge gun, bore it too small for a .22 caliber bullet and chamber for a .22 caliber blank cartridge. Incidentally, check on your local laws concerning blank guns. The first hole through should be  $\frac{3}{16}$ ". The  $1\frac{1}{8}$ "x $6\frac{1}{2}$ " piece of round rod should have the centers marked and bored. Now put it on the lathe strapping one end to the headstock center and face plate, letting the other end turn in the steady rest and bore all the way through the bar from one end, with a  $\frac{3}{16}$ " drill. Lengthen the drill by welding a piece of  $\frac{3}{16}$ " rod on the end of it. Next turn barrel down to dimensions—Fig. 1—and cut the threads in the end of it; these are 8 pitch threads. Four turns are enough. Now counter bore the breech for the blank cartridge first, next for the rim of the shell and check the fit.

The breech block is next. This is  $1\frac{3}{8}$ " long x  $1\frac{1}{4}$ " in diameter. Bore in and thread back to the block just  $\frac{5}{8}$ " deep, so that the

breech block fits the end of the barrel.

The hole for the firing pin must be bored in now, so that its center is  $\frac{1}{64}$ " in from the rim of the cartridge  $\frac{3}{32}$ " off center of the breech. Bore a  $\frac{1}{8}$ " hole clear through. Now from the back end bore in  $\frac{5}{16}$ " with a  $\frac{3}{32}$ " drill and tap with a  $\frac{1}{4}$ "x28" thread tap. Thread a piece of  $\frac{1}{4}$ " rod, bore a  $\frac{1}{8}$ " hole in the end, and cut off this collar  $\frac{1}{4}$ " long. Now make the firing pin from  $\frac{3}{16}$ " rod  $\frac{1}{8}$ " in diameter with a collar on it  $\frac{3}{16}$ " thick  $\frac{1}{2}$ " from one end. It is 1" long. Taper off one end in the last  $\frac{1}{16}$ " to  $\frac{3}{16}$ " in diameter. Harden both ends and insert with a small light spring under the collar and screw in the  $\frac{1}{4}$ " collar you have just made. The firing pin is now complete—Fig. 3 and Fig. 6.

The hammer and trigger come next. These are cut out as per sketch in Fig. 4 and Fig. 5 respectively, and mounted in the side plates Fig. 7, which are fastened with 4-36 screws to a piece of  $\frac{1}{4}$ " square steel rod  $1\frac{1}{2}$ " long that in turn is screwed to the breech block with 6-32 screws Fig. 3. The hammer is pinned to the shaft, see Fig. 4, and the end of the shaft is slotted for the coiled hammer spring; the other end of the spring is caught under a washer and screw of the side plate. The trigger is turned as per Fig. 5 and the flat spot of the cam filed until there is just

Parts of cannon ready for assembly. Breech and firing mechanism is not yet pressed on to barrel. Note that string is attached to the trigger arm.

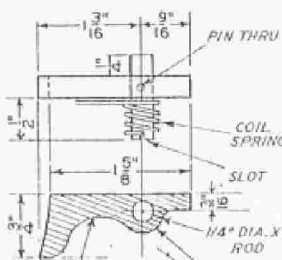
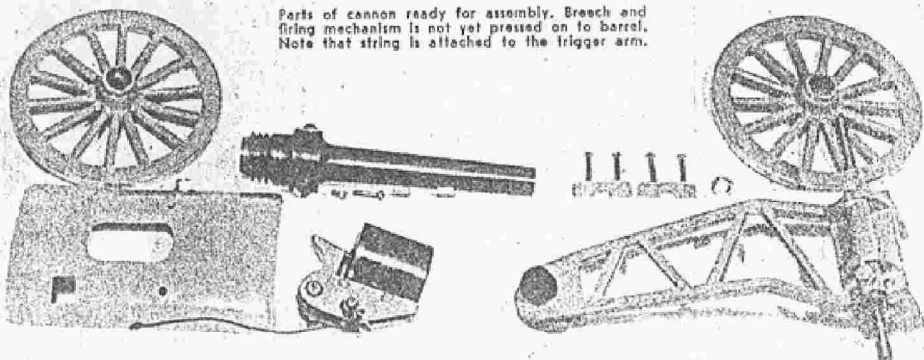

FIG. 4 HAMMER (1/4" STOCK)

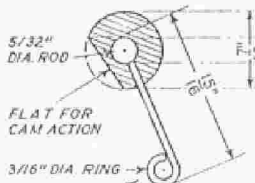

FIG. 5 - TRIGGER (TURN FROM 1/2" ROD)

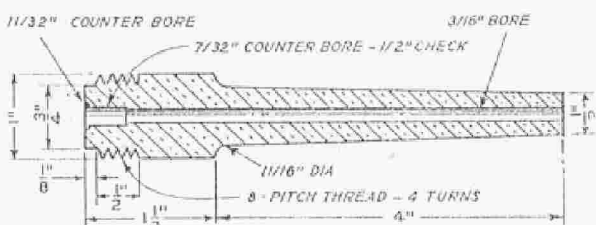

FIG. 1-SECTION THRU BARREL

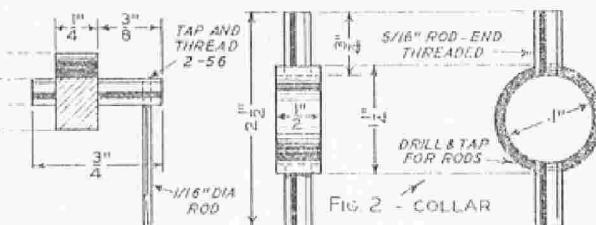

FIG. 2 - COLLAR

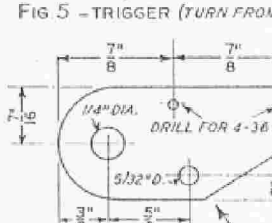

FIG. 7 - SIDE PLATES - MAKE 2 OF 1/16" BRASS OR IRON

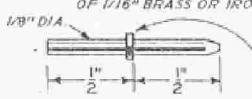

FIG. 6 - FIRING PIN 3/16" DIA. AT SHOULDER

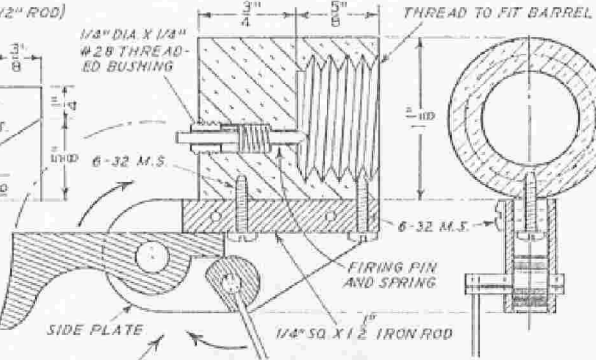
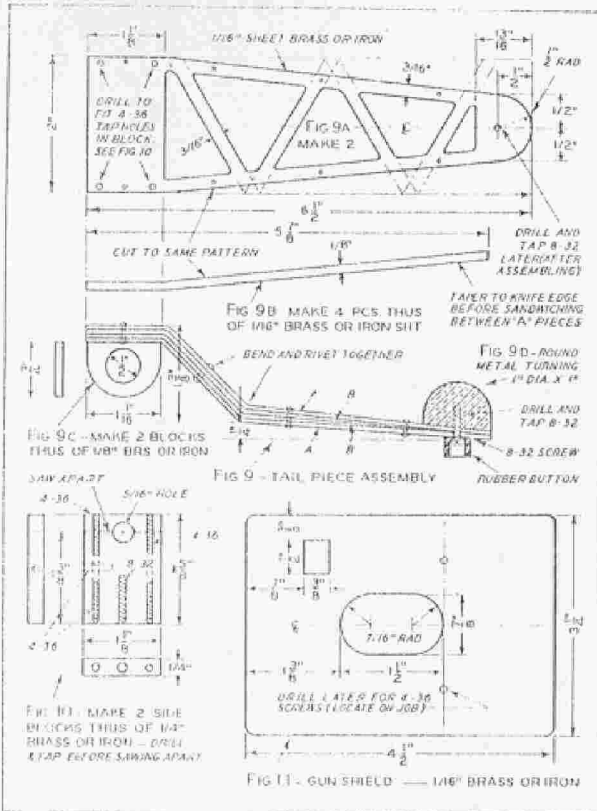

FIG. 3 - BREECH BLOCK AND TRIGGER MECHANISM ASSEMBLY

Details and dimensions of cannon barrel and firing mechanism. Off-center firing pin is designed for rim-fire .22 cal. blanks.



Gun shield is single piece, as shown, but tail piece is built up as in full sized cannon. All dimensions shown. Careful finishing counts.

out using heavy metal saws. The design is shown in Fig. 9. The front is first assembled and riveted together. While holding in a vise, the first bend is made and this section riveted together. Now make the next bend and rivet the rest together.

The side blocks for the cannon supports are made 1/4" blocks of iron or brass—Fig. 10. Bored for the cannon supports and drilled and tapped at both ends for 2 No. 4-36 machine screws, the tops are then sawed off directly across the center of the support holes. These top blocks are reamed to pass a No. 4 screw easily. The front is drilled and tapped for No. 4 screws to hold the shield. Now mount the cannon support blocks on the carriage frames by drilling the carriage frame for the screws in the bottom of the block. Make Fig. 9-C of 1/8" iron or brass—2 of them for the axle. Bore the axle for 8-32 machine screws and bore and tap the carriage for 8-32 screws.

Slip these blocks Fig. 9-C over the axle and bolt the axle into place with 1"-8-32 machine screws threaded into the cannon support blocks. Make the shield of 1/16" iron or brass as per Fig. 11. It is 3 1/4" wide and 4 1/2" long. Cut the holes as specified

clearance. An arm for the trigger is screwed into a hole tapped for a 2-56 thread. A light coil spring around the trigger arm hooked to the trigger and through a hole in the side plate provide trigger tension. When trigger action is complete and assembled on the breech block, turn a collar to a squeeze fit on the barrel. Fig. 2. This collar when hot is driven on to the cannon barrel by compressing in the vise. You may now try out the trigger action on a real cartridge holding the cannon in the vise. The axle is made as per Fig. 8. The wheel boxes next and the axle nuts after that: threads 1/4" 28 threads. The foot or tail piece of the carrier is now cut from 1/16" brass, aluminum, or iron, and is sawed out with hack saw. If aluminum, it may be jig-sawed side view of cannon. This barrel is blued.

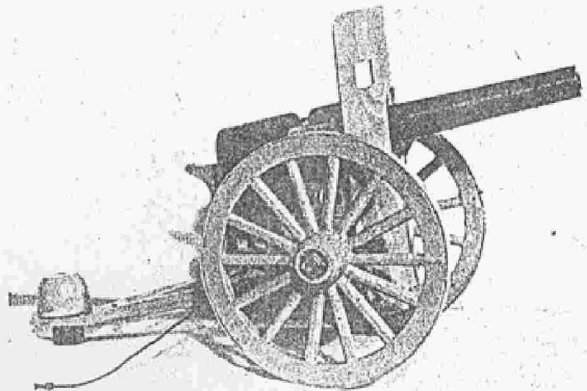

Wheel and axle construction. Rims are laminated, then turned.

and mount on the front of the frame with two 4-36 machine screws passed through  $\frac{3}{8}$ " sleeves to hold the shield out from the wheel hubs.

Next mount the cannon in the carriage. The last and final task is the making of two wagon wheels of wood exactly 4" in diameter less rim. The rims are made of 12 pieces of  $\frac{1}{8}$ " wood cut and glued up with casein glue as per Fig. 12 two layers deep. These pieces are then turned on the lathe to an outer diameter of 4" and an inside diameter  $3\frac{3}{8}$ ".

The spokes are made of  $\frac{1}{4}$ " x  $\frac{3}{16}$ " pieces of wood rounded to oval shape. There are 14 of them in each wheel. Lay out a circle on a  $\frac{3}{4}$ " x 5" square block of wood  $3\frac{3}{8}$ " in diameter and mark off exactly 14 equal spaces. Draw these spoke lines to the center; see Fig. 13. Bore a hole in the center a snug fit for the wheel boxes, see Fig. 8. Cover this block with waxed paper. Insert one of these boxes in the hole so that it stands

Looking at model seige gun from breach end. String fires it.

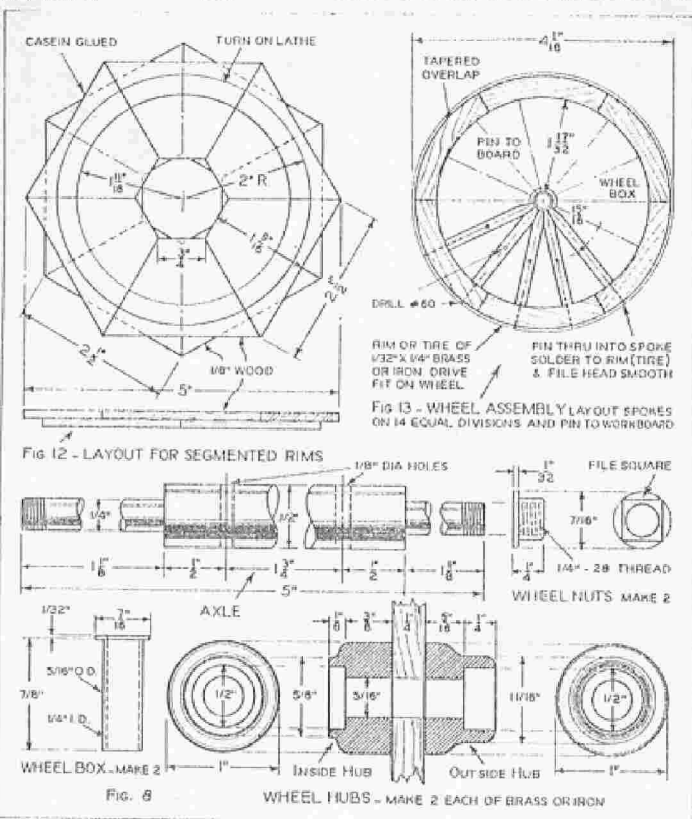
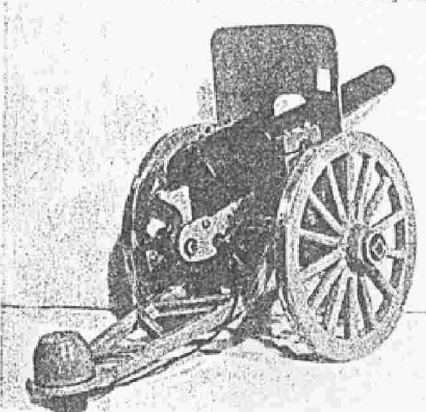

above the board about  $\frac{1}{16}$ ". Fasten the rim of the wheel to this block at the circle line with brads. Now cut spokes and fit them on the lines of the spokes. Use a No. 60 drill to bore through each spoke. When in place, hold with a pin driven through this hole and drill through the rim with a No. 60 drill into the end of each spoke. Drive a brass pin  $\frac{1}{2}$ " into the end of the spoke, cut off and put a drop of model airplane glue on the end of each spoke. When the spokes are complete, remove the wheel box and insert it in  $\frac{1}{2}$  of one hub and put plenty of model airplane glue on the spoke ends and half hub, and re-insert the wheel box in the center of the spokes pushing down firmly.

Next cut the tires from  $\frac{1}{32}$ " sheet brass  $\frac{1}{4}$ " wide, bend around the wheel, and cut for an overlap of  $\frac{1}{4}$ ". File these overlaps to fine tapers and solder the ends together. Now slip the tires over the wheels. They should be so snug that they have to be driven on. At 4 places around

## HOW TO MAKE A SLING

No boy can go through life without a sling. All you need for one is the fork of a branch, two rubber bands  $\frac{1}{4}$  inch wide and 5 inches long, a piece of leather  $1\frac{1}{2}$  inches by 3 inches—an old shoe top will do—and some heavy cord. Fig. 1 shows how to assemble and use the weapon. If you care to match your skill with David's, you will have to make your sling out of two pieces of stout cord and a piece of leather, as shown in Fig. 2. David put a stone in the sling and holding both ends in one hand, whirled the sling round his head. When he suddenly let one end go, the stone was hurled with great force straight at Goliath's head.

Fig. 1

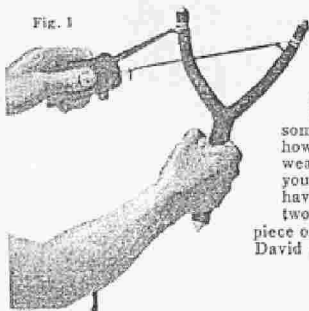

## Toy Pistol Shoots Spool Bullets

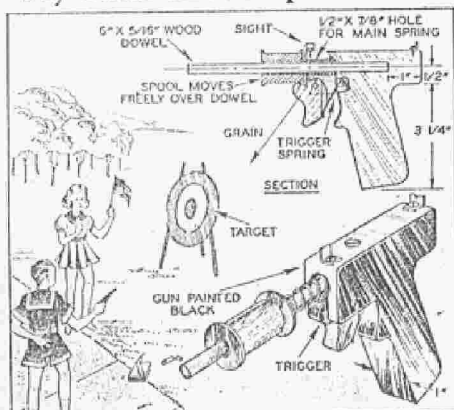

Here's a safe toy pistol for Fourth of July celebrators. Firing thread spools, the gun is claimed to be quite accurate.

## Model Siege Gun

The wheel drill holes with a No. 60 drill and drive in pins about  $\frac{1}{4}$ ". Cut them off. Put a drop of solder on them and file smooth. These pins will prevent the tires from ever loosening or coming off. When the glue is dry, remove the pins holding the spokes and rim to the board, and take off the board. Now glue the other half of the hub onto the wheel over the end of the box sticking through. The other wheel can be built on this same board. These are very sturdy wheels, and can be mounted on the cannon using the square nuts—Fig. 8.

The weight on the tail piece—Fig. 9-D—is made of iron rod tapped for an 8-32 machine screw. This screw is inserted through a rubber pad and a threaded hole in the tail piece and used to hold this tail piece weight in place. The weight keeps the cannon from tipping forward when the breech block is removed for firing. A piece of 7" x  $\frac{1}{8}$ " drill rod makes an excellent ramrod for extracting cartridge shells and a piece of No. 22 insulated copper wire twisted double with a loop in one end acts to pull a cleaning rag through. The cannon may be blued with some quick bluing material and the balance painted gray.

UNLIKE most toy pistols, the hole in the "spool gun" shown above is in the bullet rather than the barrel. Employing discarded thread spools for projectiles, this novelty is safe for any child to use. The spool is slipped over a 5/16-in. dowel (a penny pencil will do) and is held by a notch in the wooden trigger. Pressure on the trigger releases a spring which forces spool off dowel. The trigger is cut from a  $\frac{3}{8}$ -in. block of hardwood. The sights are bent to shape from thin sheet metal, the rear being  $\frac{3}{8}$ -in. high and the front,  $\frac{1}{8}$ -in.

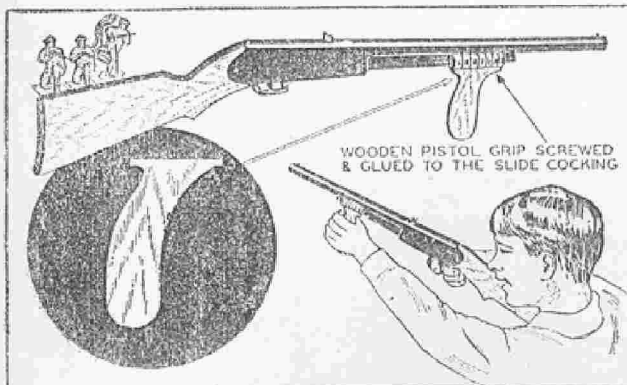

## Pistol Grip Improves

## Repeating Air Rifle

THE wooden grip on the slide-cocking action of a repeating air rifle is more readily operated if a carved wooden pistol grip is fastened on to it as shown. It is also easier to hold gun when aiming. A coping saw and penknife are all the tools needed to make the handle, aside from sandpaper.

—A. E. O.

# A MODEL Brass CANNON

Shoots .22 Caliber  
Cartridges

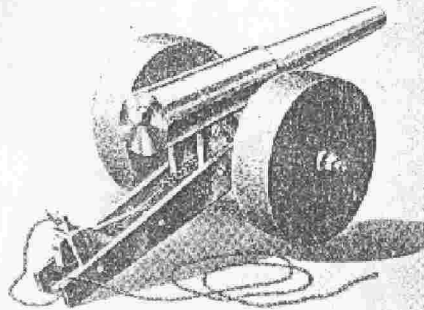

**C**LAUDE J. SISK of Washington, D. C., writes about a small cannon he has made out of brass and cold rolled stock, and which shoots .22 caliber cartridges, either blank or loaded.

Briefly his description runs like this: The gun can be made in any work shop which has a small lathe. The barrel is of round brass stock, and is  $\frac{3}{4}$ " in diameter at the breech and  $\frac{7}{16}$ " diameter at the muzzle. The barrel is bored on the lathe with a No. 2 drill. The barrel is milled out, as shown in the drawing below, for the side clamps on the bottom.

The wheels are of wood, turned on the lathe. If close-grained hardwood cannot be had, use red fiber, altho hardwood is preferable.

Here is an isometric of Claude Sisk's little gun.

Side clamps and tail piece are  $\frac{1}{8}$ " cold rolled steel. Hammer is  $\frac{1}{4}$ " c. r. s.

The materials list: 1 pc.  $\frac{3}{4}$ "x6" round brass; 2 pcs.  $\frac{1}{8}$ "x $\frac{1}{4}$ "x $\frac{1}{4}$ " c. r. s.; 2 wood or fiber wheels; 2 pcs.  $\frac{1}{8}$ "x $\frac{1}{4}$ "x $\frac{1}{4}$ " c. r. s.; 4 spigot washers  $\frac{1}{8}$ "; 1 pc.  $\frac{1}{8}$ "x $\frac{5}{16}$ "x $\frac{1}{4}$ " c. r. s.; 1 pc.  $\frac{1}{8}$ "x $\frac{5}{16}$ "x $\frac{1}{4}$ " c. r. s.; 1 length  $\frac{1}{8}$ " screen door spring 2".

You will also need 1 pc.  $\frac{1}{8}$ " round c. r. s. for rivets and the axle.

The fiber washers are to separate the frame and the fiber spacers on the axle. The trigger and the hammer can easily be worked out with a hack-saw, a drill press and a file.

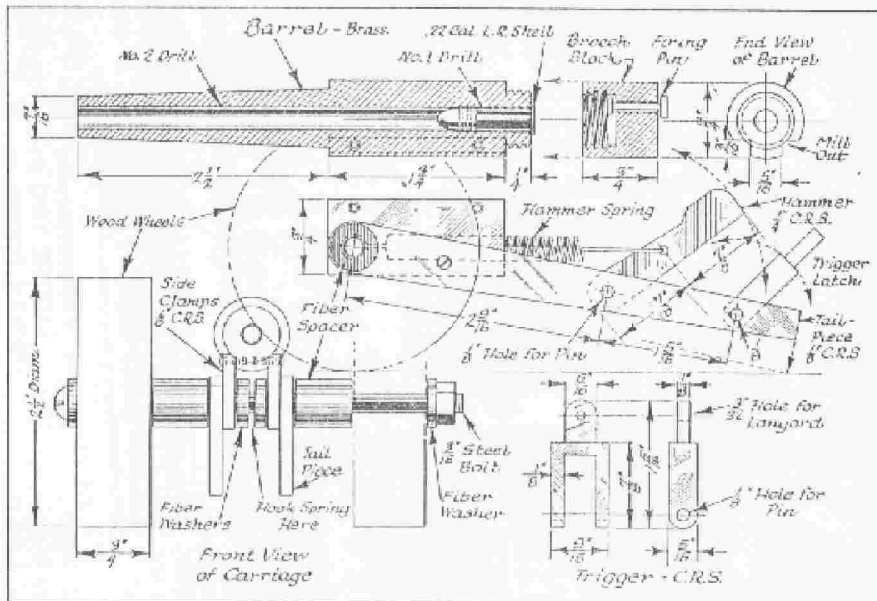

The barrel and the wheels are turned on the lathe, also the breech. The rest of the parts are stock material. Note the breech with firing pin which is hammered by a cold rolled steel hammer. The trigger is pulled by a breech cord and can be made out of cold rolled stock by sawing with a hack-saw and then filing.



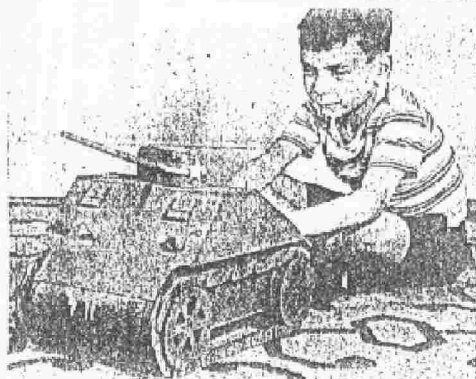

Treads turn on wooden wheels when tank is moved.

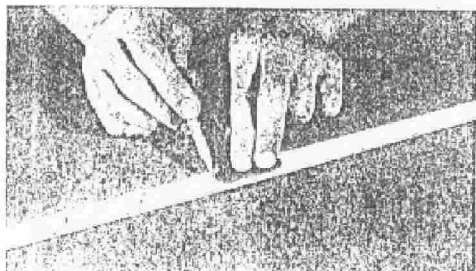

Use metal guide to mark out tread links on plywood.

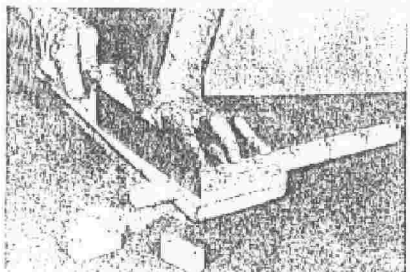

Hull strips and saw. Fasten links with wire nails.

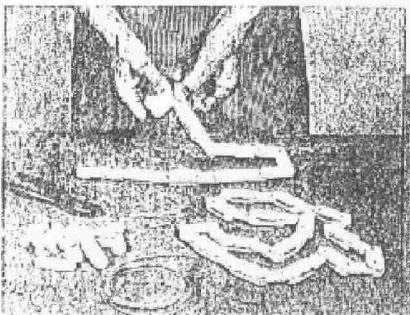

## Tank for Junior

A realistic toy following the design of the Army M-4 tank. It has a moving tread, oscillating turret and noise for gunfire.

by Charles and  
Bertram Brownold

**Y**OU can make this tank at no cost whatever; all of its parts are small enough to be made of scrap and "bits and pieces." Soap boxes and cigar boxes will furnish almost all you need with the exception of material for the links of the treads.

Ninety links are needed, 45 in each tread. They can be made easily and quickly by mass production adapted to the home workshop.

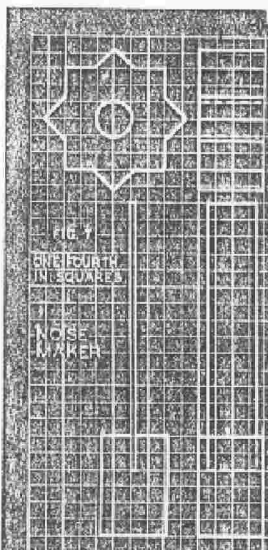

Wheel of noise maker at right rubs against slot.

Two pieces are needed for each side as indicated.

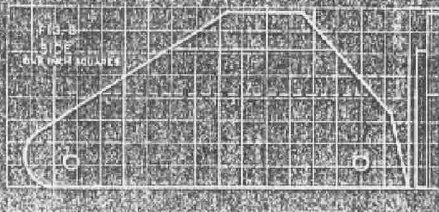



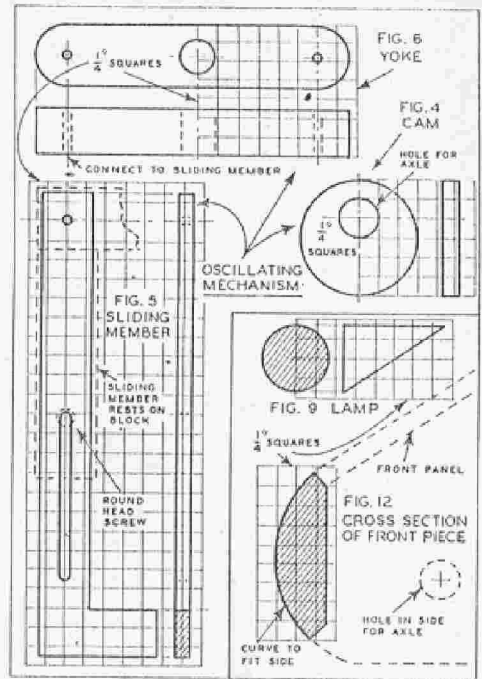
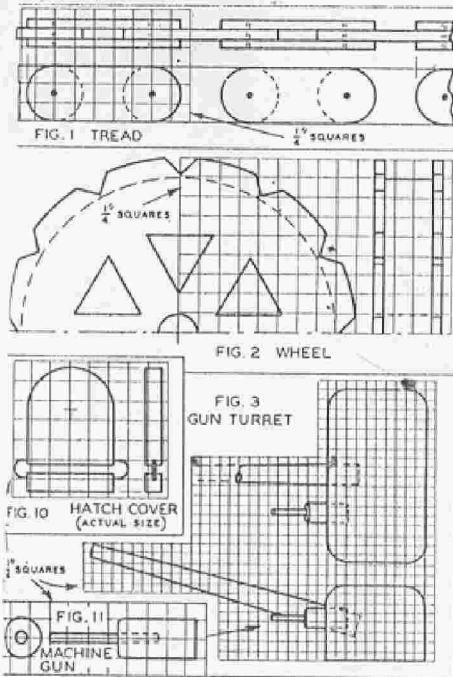

Make a sheetmetal marking guide the shape of a link. For dimensions see Fig 1. Use plywood or hardwood about  $\frac{1}{4}$ " to  $\frac{3}{16}$ " thick and cut it into strips as wide as a link. Mark one strip with the metal guide as shown in the photo, marking not only the outline of the link but also the two center points of the link's semicircular ends. Then clamp 5 or 6 strips together with



the marked one on top and drill  $\frac{1}{16}$ " holes at all the center points. This must be done accurately as the holes must be in the same location in all of the links. Use a drill press if possible. Then drive light nails into the holes, saw the stack of strips into blocks, and round both ends of each block on a sanding disk. Now all you have to do is to separate each block

Wheels are glued up from three pieces; see Fig. 2.

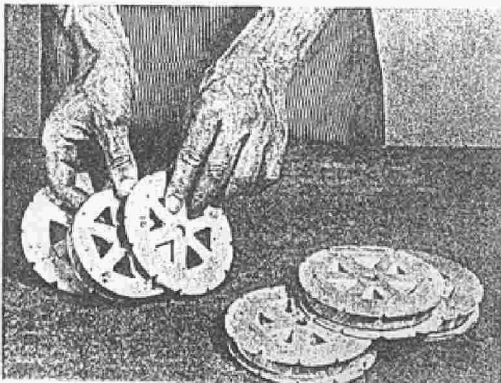

Assembly of tank oscillating mechanism.

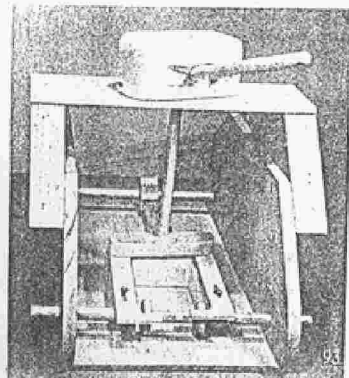

into links and the job will have been done in jig-time.

The links are put together to form endless treads by means of wire pins through the holes. Thirty pins are needed for each tread; put them in straight and then bend them, leaving a little room for play as the tread when finished must be flexible.

Each wheel can be turned of one piece or can be made of three pieces glued together. For the design and dimensions of the wheels see Fig. 2.

The turret is a solid block with its vertical and upper edges rounded off. See Fig. 3. A tapered piece of dowel stick glued into a hole in the block represents the tank's big gun, while a smaller piece of dowel with a nail in it represents a machine gun. Motion is transmitted to the turret from the front axle to which two cams (Fig. 4) are glued. As the axle turns, the cams press alternately against each of two members (Fig. 5) which are connected to a yoke (Fig. 6) through which a piece of dowel stick is glued. The upper

end of the dowel enters the turret while its lower end pivots in a socket drilled in a block screwed to the tank's floor. The connecting members are also on blocks, permitting them to slide over the front axle. These members are held in correct alignment by screws passing through their slots and entering the blocks underneath.

Each side of the tank is made of two pieces of wood glued or screwed together. The thick piece overhangs the treads. For shape, dimensions and construction of the sides see Fig. 8. Four panels (three sloping and one horizontal) are screwed to the sides. Secured to the front panel are two "lamps" (Fig. 9), two "hatch covers" (Fig. 10), and a "machine gun" (Fig. 11). The hatches and lamps are held in position by screws from the inner side of the panel. The machine gun is glued into a hole through the panel and into a small block glued on the panel's inner side. Below the front panel is a piece with a curved face, an end view of which is shown in Fig. 12.

Mechanix Illustrated June, 1939

## Throwing Targets

**DO YOU** have a good throwing arm—one that is accurate? Try it out in competition with one or two of your friends, using novel arrow parachute or catapult targets. The catapult is very easy to make and use. Nail a one-by-four board, 4 or 5-ft. long, to a small log of about 6 or 7-in. diameter and 3-ft. long, with one end of the catapult board resting upon the ground. Fasten the board to the log about 18-in. from one end, this short end to be struck with the head of an axe or sledge. To the other end tack a narrow can cover, in which a tin can will fit loosely. Place a can or rubber ball in the cover container, and strike the other end of the catapult a solid blow. The lever will throw the can or ball target high into the air, giving you a good moving target to throw at.

For the parachute target, trim out enough light cotton cloth to form a cone 12-in. in diameter at the base and about 7-in. deep. Overlap the edges  $\frac{1}{4}$ -in. and stitch them together.

Whittle or plane down a pine arrow  $3\frac{1}{2}$ -ft. long, notching the lower end for the bow cord and forcing a pin in the head. Clip off the pin head, leaving about  $\frac{1}{8}$ -in. and file it to a point that will catch in the cloth at the peak of the parachute cone. Make the parachute "life lines" of thread, using five or six of them, each about 9-in. long and attached to the edge of the parachute, spaced equally. The lower ends of the threads are tied to a heavy metal ring or washer which will slip freely over the arrow. Make a sturdy bow from a willow or strip of ash or cedar, one which will shoot the parachute arrow high into the air. At the top of the ascent the arrow will drop free of the "chute" and the metal ring

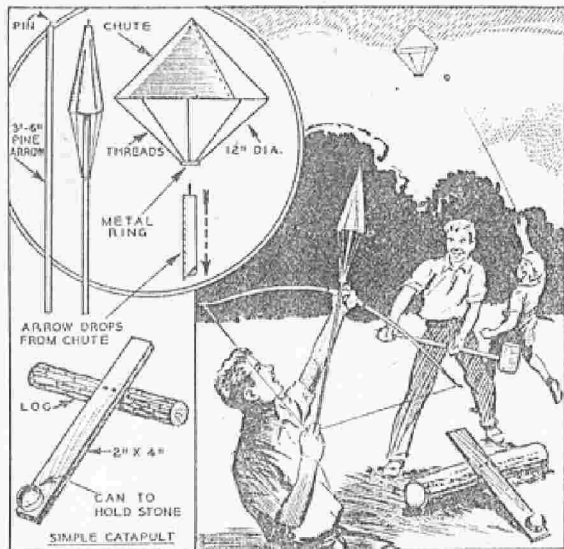

will drop, filling the "chute" with air. It makes a fine target to throw at as it descends. Shoot the arrow directly over your head so that the "chute" will not drift away too far as it floats to the ground.

## A BEAN GUN

Here is a five-shooter bean gun that almost any boy can make. First we get an ordinary bean-shooting tube (B), 14 inches long. Any metal tube of the right size to pop beans through will do. Now we must find a straight, flawless elder rod 10½ inches long. When we have taken out the pith with a ramrod, the hole left must be just the right size for our bean tube to fit into, fitting snugly. But before inserting the tube, saw off a 3½-inch length of the elder for the magazine (C). The remaining 6½ inches will be the barrel (L) of our gun. Next cut with a knife five holes in the magazine, as in G. Each hole must be just big enough for a bean to drop through. Now file a hole the same size in the bean tube (M) in the middle of the part of the tube over which the magazine is going to slide. You should make the stock of the gun (A) from a soft board 10 inches long, 1 inch thick, and 3½ inches wide. Fig. J shows the shape to which it should be cut.

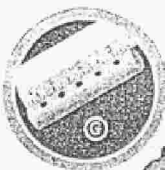

When you have cut the stock to shape, make a groove in the barrel end for the barrel to rest in (H), and saw a slot for the trigger track (I). Bore a hole in the projection of the stock

(F), and pass one end of the bean tube through it. To this end attach a one-foot length of rubber hose (K). Make a trigger out of a piece of soft wood and attach it to the magazine with a tin band (E). Lastly make the barrel fast to the stock at point D with either a tin band or a piece of adhesive tape. The chap who is clever enough to make this gun has already discovered how it works. You push the magazine to the position shown in the picture and drop a bean into each of the five holes. Whenever a hole in the magazine is directly over the hole in the tube, a bean drops through into the tube. Pull the magazine back half an inch and the hole in the tube is sealed. Now blow through the rubber hose—and pop goes the bean! Since this is a five-shooter you can blow five times without reloading. If you have made your gun well the magazine fits snugly on the tube so that no air can escape and your mighty blowing is not wasted. A little soap will make it slide easily.

SCIENCE AND MECHANICS AUGUST, 1952

# "Bombs Away!"

**T**HIS lively game will give you all the thrills of knocking the daylight out of an enemy city with well-placed "demolition bombs" without the least danger to the bombardier, although the area below is bristling with anti-aircraft guns.

The bomber (Figs. 3 and 4) slides on a revolving arm supported by a central post (Fig. 2) and is moved by hand until it is over target selected. By looking through the bombsight with its cross-wires the airman can get a direct line on target and release marble "bombs" by a hand lever. Forward of the low wing is the bomb-bay, a 1½ in. hole bored down through solid wood fuselage. Midway the wood is slotted to receive pivoted bomb-release lever. At rear of wing is bomb-sight, a piece of metal tubing set in a hole bored at an angle

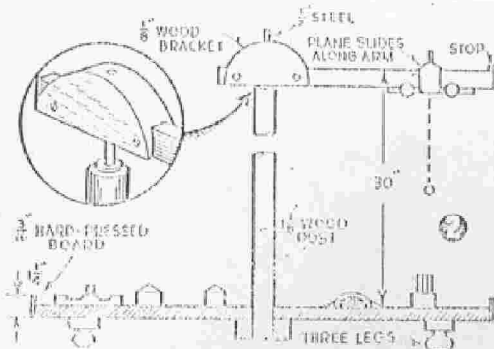
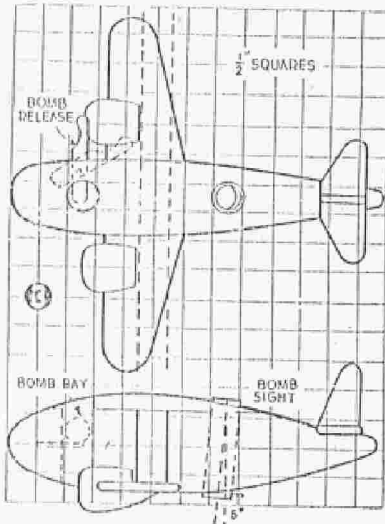
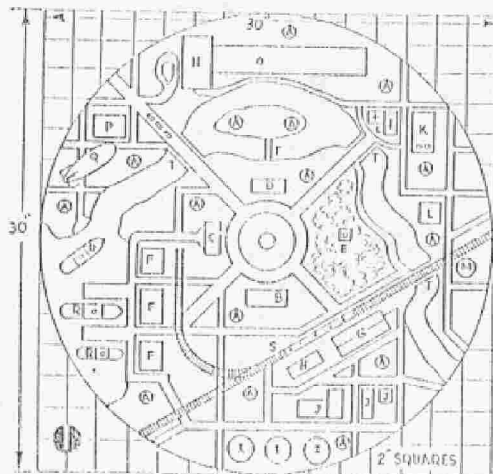
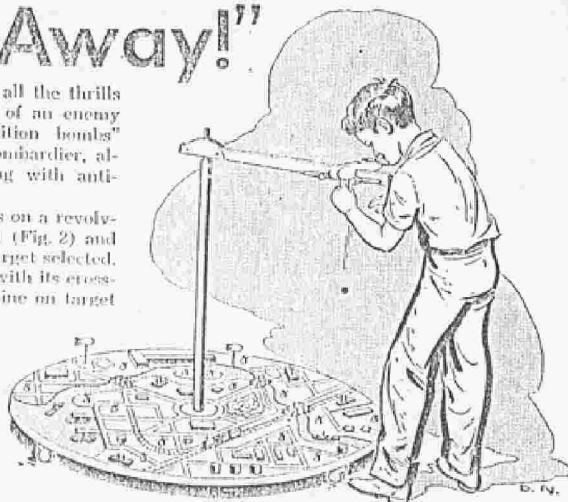

of 5 degrees from the vertical.

First scroll-saw fuselage (Fig. 4), and temporarily install release lever and bombsight. Then streamline structure and attach wings and tail assembly. In middle of fuselage is a rectangular opening for the wooden arm on which it slides. Solder 2 fine wires at right angles to upper end of bomb-sight; at bottom drill for a brad but do not solder permanently until sight has been checked.

Apply a small wad of gum or wax to brad to hold it in place until sight

MATERIALS LIST—"BOMBS AWAY" GAME.

No.	Req'd	Description	Item
1	pc.	1/2 x 30 x 30", plywood	platform
3		sturdy drawer pulls	legs
1	pc.	1 1/2 x 30" dowel	center post
1	pc.	2 x 2 x 48" white pine	plane, buildings, roll- ing stock, etc.
1		1 1/2 x 11 1/2" brass tube	bomb sight
1		1/4 x 11 1/2" strip tem- pered Masonite	rim of platform
1		1 1/2 x 6" steel bar	axis
24		1 1/2" steel ball bearings	demolition bombs or marbles

Paint, glue, brads, screws

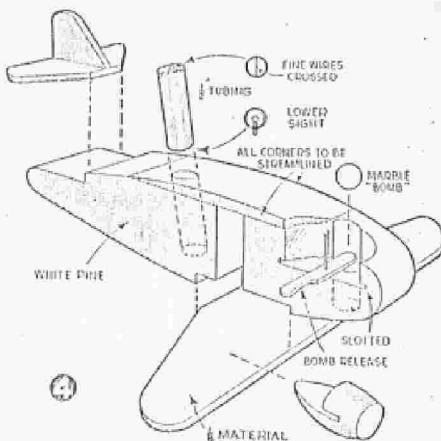

has been properly adjusted (Fig. 5). Suspend a small plumb-bob, such as a 22 bullet, by a thread from center of bomb-bay, and sight through eye-piece. Bottom of bob and line of vision along sights should coincide. Move brad slightly up or down in hole in tube to adjust, then solder brad in place.

Paint on platform buildings, tanks, bridges, etc., or construct 3-dimensional subjects designed to collapse or topple over (Fig. 6). Beveled roofs cause end walls to spread under a direct hit, theoretically wrecking the building. Trains, boats and bridges are balanced on a narrow base and fall over under a direct hit. The barrage balloon, precariously balanced on a wire loop, is easily knocked down. A rim around the circular platform prevents bombs from rolling away. Streets of the city (Fig. 1) are painted gray, river light blue, railway black, buildings in appropriate colors or camouflage, and unoccupied spaces green.

Each bombardier is supplied with a dozen bombs of one color, different colors for each player. Tally correct number of points (see Table A) for various targets; the largest number of points are

for the most difficult targets, which, of course are the smallest. When a hit is made on a hospital, school, church or library, the bombardier loses points, as indicated. First bombardier to tally 151 points wins the game.

Now you can organize a bombing squadron and let the small fry fire away without your having a care in the world about any real damage being done.—HIT SURELY.

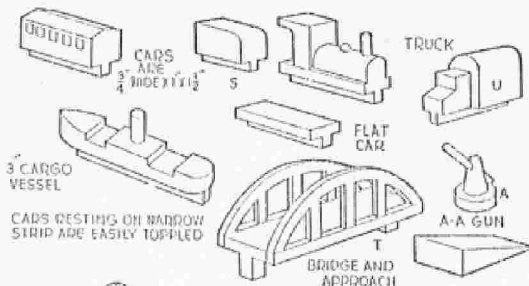
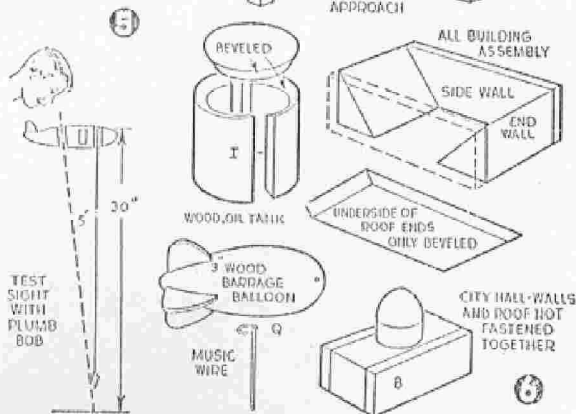

TABLE A—TALLY POINTS

Key	Target	Each point
A	Ack-neck guns	5
B	City hall	1
C	Library	-1
D	School	-8
E	Monument (in park)	-1
F	Washhouse	3
G	Railway station	10
H	Freight station	7
I	Oil tank	6
J	War factory	11
K	Power house	12
L	Hospital	-16
M	Water tower	1
N	Bongar	9
O	Runway	4
P	Church	-3
Q	Barrage balloon	2
R	Cargo vessel	6
S	Railway car	2
	Locomotive	4
T	Bridge	11
U	Truck	3



# Gun for "RUBBER BANDITS"



for trigger. Mark with a center punch and drill  $\frac{3}{16}$  in. holes before sawing out these parts. Smooth up with sandpaper, rounding all edges slightly, and shape trigger to a comfortable finger fit.

SCIENCE AND MECHANICS, JUNE, 1950

JUNIOR can have plenty of safe fun with this gun. It is a honey for target practice and if someone is accidentally plunked with a rubber band it isn't serious. It does shoot straight, the ammunition is cheap, and as for materials and time to make, well, just a few scraps of lumber, a nail or two, a few screws, a small spring, and an evening in the shop will make your youngster the envy of all the kids in the neighborhood.

Make the two sides of  $\frac{1}{4}$  in. and the center section of  $\frac{3}{8}$  in. plywood. Lay out these pieces, using  $\frac{3}{8}$  in. squares (see drawing) directly on plywood and then saw them close to the outline with a jig or coping saw. Drill a small  $\frac{1}{8}$  in. starting hole for the blade to enter for each of the two cutouts, the trigger mechanism and spring location spots, in the center section. Now glue center section to left side piece of gun. While waiting for glue to set, lay out trigger mechanism pieces on the piece of hardwood (preferably rock maple). Keep direction of grain

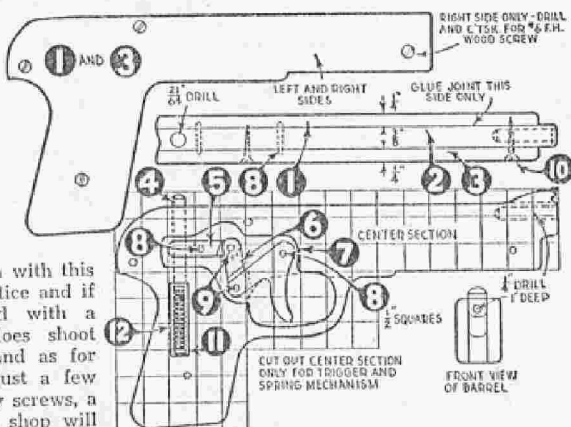

Make the long and short  $\frac{3}{16}$  in. dia. pivot pins from the smooth round portion of a finishing nail. For the plunger end spring plugs, use  $\frac{5}{16}$  in. dia. birch dowel rods or, if you have a lathe, turn them out of any hard wood. If you can't find a 1 in. long (free length) spring of about  $\frac{5}{16}$  in. O.D. in your hardware junk box, alter the cutout and plugs to make the one you find do the job. Or, if you have a piece of approx.  $\frac{1}{16}$  in. diameter spring or piano wire, make your own spring. For a spring with  $\frac{5}{16}$  in. O.D. clamp a  $\frac{1}{4}$ -20NC bolt and one end of wire also in a vise. Now take about a 1 ft. length of wire, grasping free end with pliers and, with tension on the

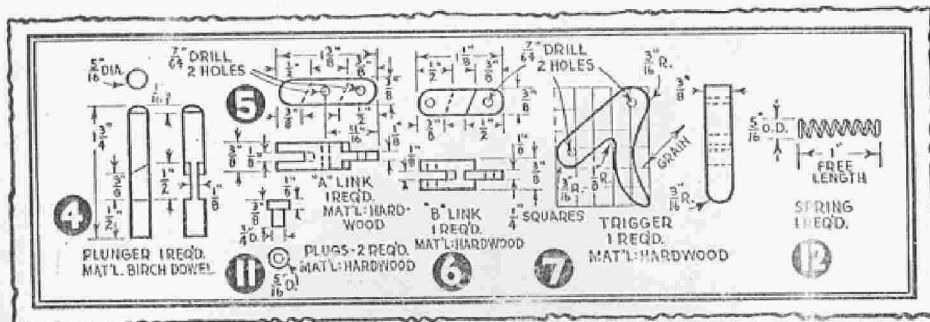



## MATERIALS LIST—RUBBER BAND GUN

No.	Part	Req'd	Material
1	Left side	1	1/4" plywood
2	Center	1	3/8" plywood
3	Right side	1	1/4" plywood
4	Plunger	1	5/16" birch dowel
5	"A" Link	1	3/8" hardwood
6	"B" Link	1	3/8" hardwood
7	Trigger	1	3/8" hardwood
8	Long pins	2	3/32 x 5/8 in. steel
9	Short pins	2	3/32 x 3/8 in. steel
10	FH screws	4	No. 10 x 3/4 in. steel
11	Plugs	2	5/16 birch dowel
12	Spring	1	5/16 O.D. steel

Glue and Paint

wire at all times, wind it into bolt threads on the bolt. If you have a lathe or drill press, make a spring on it but be sure to run the machine very slow if power is used or better still have someone turn it by hand while you put tension on the wire. Wind spring slightly longer than needed as it can be cut easily to length by notching with the corner of a file or on a grinding wheel. Grind ends flat and fit the plugs. Spring should be compressible to at least  $\frac{3}{4}$  in. to allow plunger to be depressed sufficiently to release rubber band. If you can't get it down to this length,

stretch it out slightly, shorten overall length and try it again.

With moving parts made, and if the glued joint has set, mark out and drill all holes to make assembly of trigger mechanism. Note that pivot holes for long pins are drilled with a  $\frac{7}{64}$  drill about  $\frac{1}{8}$  in. deep in each of the two sides, on the inside of course. Also locate and drill  $\frac{1}{4}$  in. hole for plunger. All parts must work freely but not too loosely before putting on the right side. A little powdered graphite will aid in smoothing gun's operation. Drill clearance holes with a  $\frac{5}{64}$  in. drill and countersink  $82^\circ$  through side piece for 4 #6x $\frac{3}{4}$  in. flathead screws before final assembly is made. Drill a  $\frac{7}{32}$  in. hole in each location where screws enter center section to make driving of screws easier and prevent any accidental splitting of the job at this most crucial point. Applying laundry soap will also aid in driving the screws.

With assembly complete, round corners for appearance and comfort. After final sanding, remove all sanding dust, and give gun a coat or two of chrome aluminum paint, black enamel, or a bright colored one if you choose. Let it dry and give it a waxing.—R. S. LINDENMEYER.

## PNEUMATIC TARGET PISTOL

Mechanix Illustrated Aug., 1942

by Edward F. Waldron

Making this pistol will be excellent training for your metal lathe work.

**T**HIS air pistol is an interesting toy, yet it shoots hard enough to break a milk bottle, and can be used for target practice or even for killing small game at reasonable range. It must, therefore, be given the careful handling required for any gun or weapon capable of inflicting a wound, however slight.

The pistol is essentially a metal-turning lathe project, and anyone possessing such equipment in his workshop will have no difficulty with the elementary gunsmithing involved. The drawings give necessary details and dimensions; a brief study of the sectional sketch will make clear the gun's simple but effective construction and firing action. The force with which the pellet is ejected from the muzzle depends upon the amount of air pressure pumped into the chamber, and needless to say, entire success of the gun's operation is based on a perfect seating of the valve.

The barrel is the first piece to be worked on. Bore it from a piece of 9"x $\frac{3}{4}$ " piece of soft iron rod. Start the boring with an 11/64" drill. When this drill is as deep as it will go, use another 11/64" drill to which a piece of  $\frac{5}{32}$ " drill rod has been welded. It is preferable to set the  $\frac{3}{4}$ " rod in the lathe strapped against a headstock center with the other end in the center rest. Be extremely careful to have your centers properly aligned, turn slowly, and avoid over-heating of the drill.

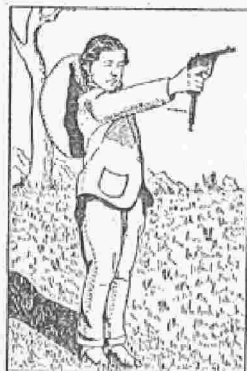

Bore from one end all the way. When the hole is complete, lap it carefully until a B B shot just falls through freely but with no real clearance.

The next task is to turn the barrel to the dimensions of Fig. 1. Counterbore the rear of the barrel 1 $\frac{1}{8}$ " deep and tap with a  $\frac{1}{2}$ " No. 20 tap. Counterbore the rear of the barrel for  $\frac{3}{4}$ " more with a  $\frac{3}{8}$ "

drill. Now turn a piece of brass rod to a tight driving fit for this portion and drill a 5/32" center hole. With a taper reamer ream so that a B B shot falls halfway through and sticks. On completion drive this insert into the  $\frac{3}{8}$ " counterbore, and check with a B B shot. The sights are now made for the barrel. They are turned out of brass



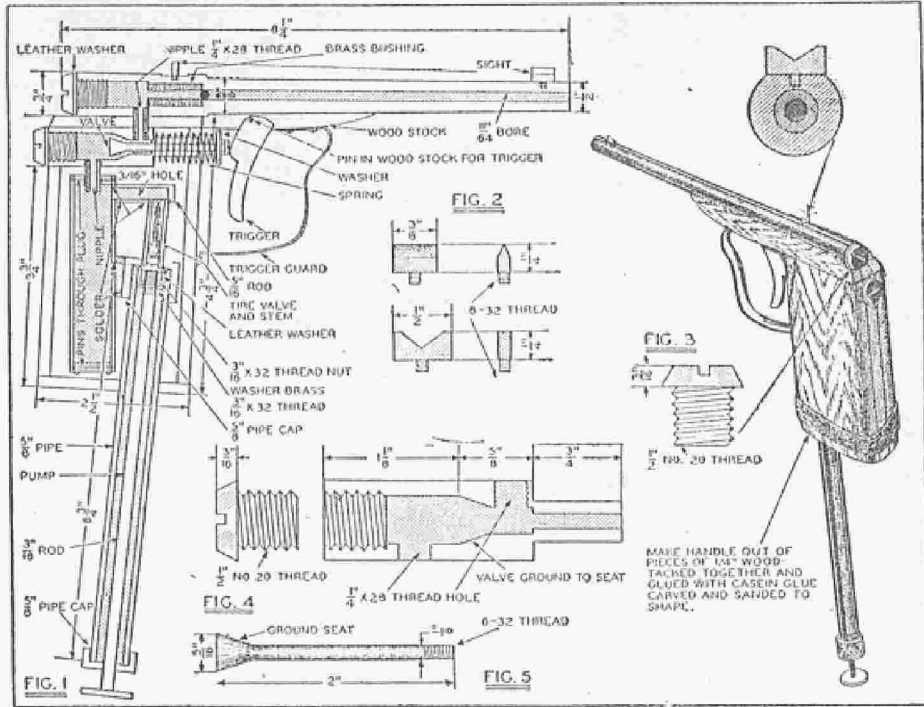

or iron, filed flat and screwed into tapped holes in the barrel. See Fig. 2. Next make the plug for the rear end of the barrel as in Fig. 3.

The trigger chamber is now made. Again, careful work is called for. It is made as per Fig. 4 of 3/8" stock. The valve (Fig. 5) is made of steel, preferably, and ground to a perfect fit, the valve stem being lapped, into the valve chamber. A satisfactory but shorter-lived valve may be made of a piece of rubber tubing slipped over a brass valve and cemented into place. The release for the air is connected by a threaded nipple made of 1/4" iron threaded 1/4"x28 and drilled with a 5/32" hole. This nipple is screwed into the air release hole of the trigger cylinder and into the rear chamber of the gun barrel. For permanence these may be brazed or soldered into place. Clean iron solders with a hot iron and good flux.

The supply chamber is made of 1/2" brass pipe turned out inside until the walls are about 3/32" or 5/64" thick. The ends are plugged and held with rods through the plugs. These ends are now carefully soldered in place, air tight. Connect the supply chamber to the trigger cylinder with a 1/4" nipple as you connected the cylinder to the barrel—Fig. 1.

In order to get pressure, the pump is made of 5/8" brass pipe 6 1/4" long. A pipe cap is fitted on each end and turned down to eliminate weight. A bicycle tire valve is placed in the bottom of the cap as shown in Fig. 1. This in turn is soldered

and threaded to the connection into the supply chamber and the pipe cap soldered to the supply chamber. The pump can now be completely disassembled for the replacement of the foot valve in case of leaks. The cap on the other end of the pump is bored for a 3/16" rod, a knob fitted, and a leather plunger with a washer for backing fitted for the other end. Care must be used to see that the pump cylinder is screwed clear to bottom of the cap so that the plunger can be pushed all the way to the bottom of the cylinder. The trigger is sawed from 1/16" material and the guard is made from 1/16"x1/4" brass.

When completely assembled, make the handle out of pieces of 1/4" wood tacked together and glued with casein glue. The open sections are filled with plastic wood and then the whole assembled unit is carved and sanded to shape; the trigger mounted, the guard placed, and the whole gun is ready for use.

The sights are adjusted by filing to the right height as you shoot the gun at a distance of 10 feet. Adjust the sights so that a full sight shoots 3/4" high at 10 feet on a standard air rifle target.

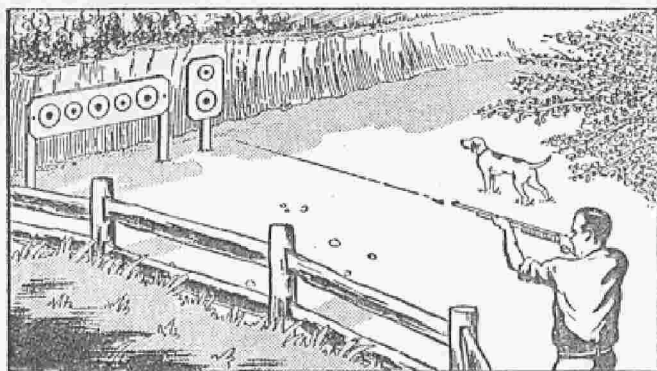

Mechanix Illustrated Aug., 1942

# PRACTICE ON CAN COVERS

by H. E. Moore

WITH government restrictions on the use of tin and other metal containers of food, tobacco, etc.; and the salvaging of such metals for use in the war emergency—the once familiar and homely garden variety of tin can that has so long graced, or disgraced our back yard ash heaps—seems about to vanish from the landscape.

With the disappearance of this universal

container that had so many uses after it had served its initial purpose — what will the small boy do for a tin can to tie to the dog's tail—or for "squackers" on Hallowe'en night—

— Even our can for fishing worms may be threatened with extinction—or moral cōmpunction against its use on patriotic grounds. To think that it may be considered an act of

sabotage to be caught sneaking down to the lake to fish with a can of worms hidden in your pocket . . . "My gawd—what is this world a comin' to—?"

Not to mention "Tin Can-less Weddings"—in which even old shoes and rubbers may be banned as bad form in this war time emergency . . . And the plight of the humble hobo (who may become an extinct animal for the duration) whose sole utensil for meat, drink and cooking depended upon the empty tin can he could pick up anywhere in his natural jungle habitat—?

Even poor old Happy Hooligan may have to doff his tin-can "Katy," long the emblem of honor of his humble fraternity, and give it to Uncle Sam— [Continued on page 168]

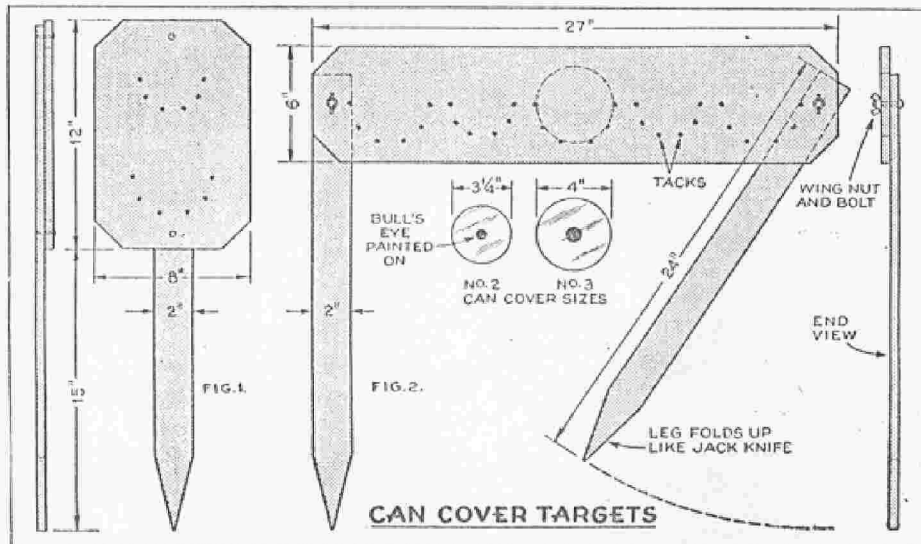

or Charlie McCarthy will hoot him off the funnies in patriotic scorn.

And the Hottentot and South Sea islander are going to suffer for these receptacles to make spangles to adorn their ears and noses—and other divers uses.

No longer perhaps, will we be able to stroll down through the pasture, along the railroad track, or past the city dump with the trusty .22—and shoot indiscriminately at old tin cans to be found lying about—as if placed there conveniently for our special use. What debt do we owe the old tin can for developing that "shootin' eye" and accuracy of aim for which the American sportsman and dough boy is noted—to stand us in such good stead now in our battle against the Japs and Hitlerian oppression—

The terrible thought comes to me—"What if there ain't going to be any more tin cans—?"

So in the agony of the night I think up this one about tin can covers for targets. Surely Uncle Sam won't begrudge us the use of a few tin can covers for use as targets. The bullets will only punch holes in 'em—so there will be no material loss—because we can bring them home again to show the folks what good marksmen we are getting to be—and then throw them in the metal, paper and rubber accumulation we are saving for Uncle Sam. Think of all the civilian rifle clubs that have sprung up all over the country using these tin can cover targets to learn the use of firearms for home and national defense—and then depositing them in the pool of scrap metal to be used for bullets, guns, tanks and airplanes to fight the war with—

In glee I jump out of bed to make a note of it.

Once more necessity is the mother of invention . . . Once more fellow sportsmen and target shooters are safe—for no longer will we have to go looking for old tin cans to shoot at. Just have mother, wife or sister save and wash the can covers she cuts off so clean and round with the modern rotary canopener—and you will soon have all the targets you want in a variety of sizes; many of them coated with that soft golden lacquer which makes them better targets to shoot at in strong sunlight, than bright tin.

With a handful of these in your side-coat pocket you can go for

a stroll or spin in the car with the .22—and with one or more of the target-support backgrounds shown in drawings on page 124—you are all-set to do your target shooting any time, any place—where the ordinances and safety will allow.

All you need to make the target-support background of either style is a piece of smooth thin board of the dimensions shown in the drawings—and some 2" diameter sticks for the leg-supports.

Background target-support shown in Fig. 1 has one solid post nailed to back of target-board—sharpened at lower end to stick in the ground to attain desired height of target.

The combination background support holding 5 targets, shown in Fig. 2, is a piece of 6" board, 27" long—with the two 24" legs bolted on back at ends—so legs can be folded up for easy carrying, or stowing away in the car. By using a washer and thumb nut on each bolt, you can tighten the movable legs in position in upright position, or when folded.

The tin cans in most common use are the No. 2 and No. 3 sizes—so I have used these sizes for illustration. But you can of course, use larger or smaller can covers, if you desire. To make the brackets to hold the targets—lay your can covers on the board-background in symmetrical pattern and draw a line around each one. Then drive 6 carpet tacks around the lower half of each circle just outside the pencil line—so can covers will slip in and out easily without binding. This done and you have a target background ready to use—on which it is an easy matter to take out the-used can covers and slip in fresh ones as needed. I use some of the can covers plain. And on some I paint

a small bull's-eye with black screen-paint or touch-up enamel. When the board-background gets pretty well shot-up—all you have to do is take the legs off and fasten them to a new piece of board.

If you have been used to shooting indiscriminately and at random at various objects you see on a stroll with the .22—you will find that a few shots on a good target in favorable light and at a known distance—will tell more than can be learned by haphazard shooting. And I think you will like the can-cover targets as a means toward becoming a better marksman.



"I have perfected an invisible substitute for clothes!"

# Tests Show Chemical Fire Hazards

**ORDINARILY**, an oxygen atmosphere is necessary to keep a fire going. But like most rules, this has its exceptions. When heated, some substances supply their own oxygen and burn without air.

Again, fire is usually thought of as being started by a spark or flame. But certain materials have such low kindling points that

just a little heat is sufficient to set them ablaze.

These and other tricks of fire are illustrated in the following experiments. In a chemistry laboratory, hazards of this nature constantly lie in wait for the unwary. So if your hobby is chemistry, better give thought to the possibility of unexpected fire.

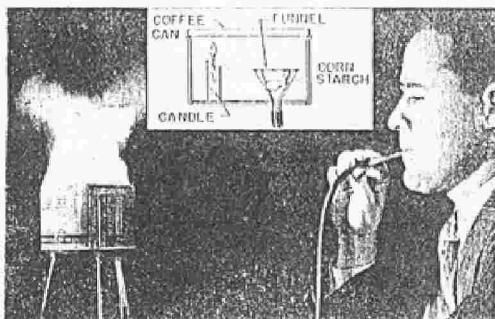

**Fine Particles Explode.** Coal dust, sugar, and starch are seldom thought of as explosives. Yet if divided finely and mixed thoroughly with air, they burn almost as readily as a gas. A dust explosion results.

You can create a harmless dust explosion with the setup at left. Warm the cornstarch a few minutes to dry it. Then put about a half teaspoon in the funnel. The coffee can must have a friction top, not one that locks in place by twisting. Set a lighted candle beside the funnel, put on the top, get your distance, and blow sharply through the tubing. Don't delay or the candle will go out.

**Heated Rod Starts Fire.** Carbon disulfide has such a low ignition point that a spark or flame isn't necessary to fire it. A heated glass stirring rod will do the trick when brought near enough.

For this experiment, pour a teaspoon of the liquid into a can cover placed on an asbestos mat. (Never handle carbon disulfide in the vicinity of an open flame.) Then heat the end of a glass rod in a candle or gas flame in another room and bring it near the liquid. If the rod is as hot as 250 deg. C., the carbon disulfide will quickly burst into flame.

**Flame Separates from Candle.** Although we don't usually consider it as such, a candle flame is actually a gas flame. Once a candle is lit, combustion heat liquifies and then vaporizes a little of the wax.

To prove that it's gas, we can cause the flame to burn for a few seconds when detached from the wick. Put a teaspoon of baking soda in a quart jar and add vinegar until the bubbling stops. This generates carbon dioxide gas. Attach a burning candle to a wire as shown and lower it gently into the jar. If carefully done, this will cause the flame to leave the wick.

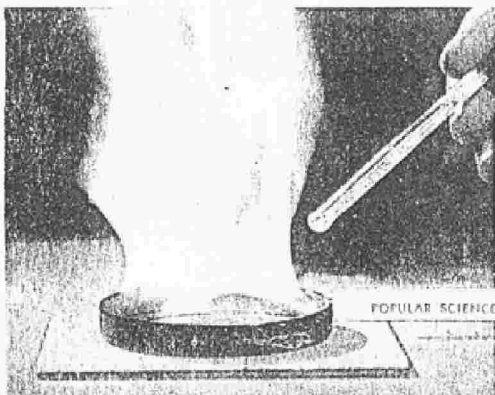

# ARMY LANDING BARGE

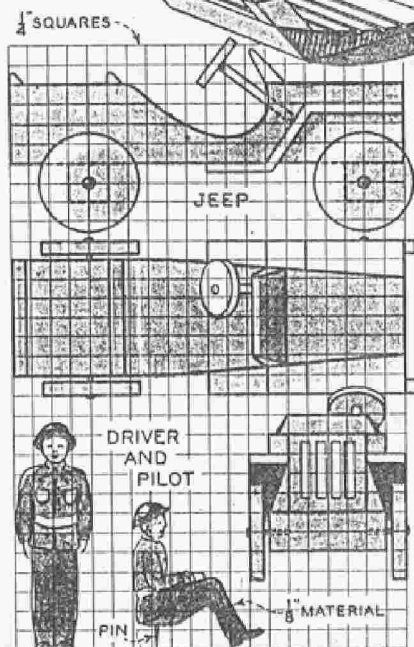
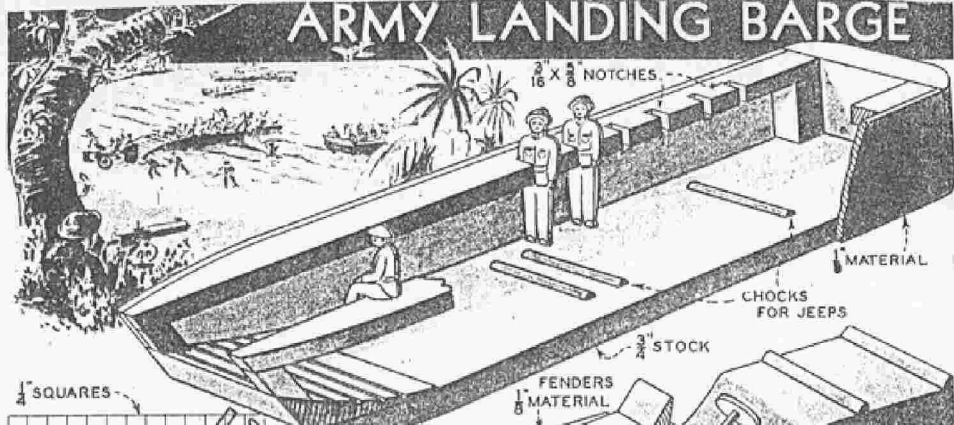

**T**HIS little invasion craft will transport a dozen soldiers, two jeeps and drivers right up to the beach of enemy territory and not wet a foot. The forward end of the barge is hinged and when let down serves as a gangplank.

Odds and ends of wood can be used for bottom, transom, sheer strips and ramp, and selected pieces of berry crate for the sides and soldiers. The jeep bodies are solid blocks of white pine, with scroll-sawed disks for wheels. All contacting surfaces of the barge should be given an application of marine glue; if that is not available in your community, use casein glue and see that all joints fit snugly. The hinges of the gangplank are well above the load water line. Sliding pins, simply nails with ends cut off, retain the gangplank in the closed position, and fixed chocks on the bottom of the barge prevent jeeps from rolling fore and aft. A slotted block serves as base for the infantrymen, who fit in

Mechanics Illustrated May, 1943

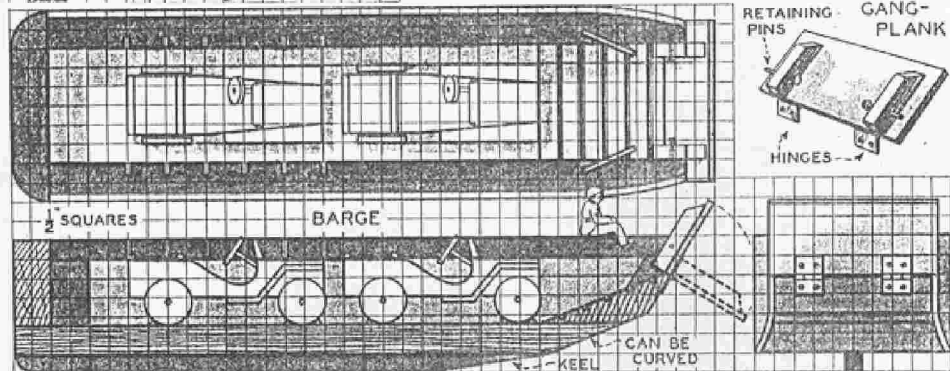

## Army Landing Barge

slots in the sheer strip while en route to the beach head.

The jeeps are made in the simplest manner possible, assembled with brads and casein glue. Steering wheel is a button mold with a dowel for steering post. The wheels turn on escutcheon pins, and will be greatly improved in performance if a short piece of tubing, such as is used in tobacco pipe-stems, is inserted for a bushing. Paint the entire craft olive drab and apply one or two coats of spar varnish. Soldiers' faces and hands should be flesh color.

## Salt Solution Is Used to Check Accuracy of Battery Hydrometer

To test the accuracy of a battery hydrometer, one garage mechanic uses a brine solution. Pure salt (sodium chloride),  $2\frac{1}{2}$  lbs., is dissolved in water, 1 gal., being sure that all the salt is in solution. The resultant mixture should give a specific gravity reading of about 1.191, accurate enough for all practical purposes. As a further check, the solution may be weighed. It should weigh about 10 lbs.—Jack Bronte, Colfax, Calif.

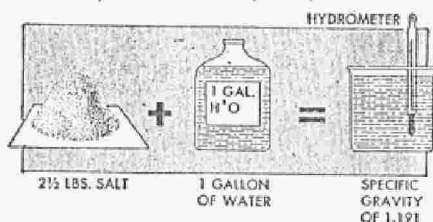

## Tin-Can Generator Makes Hydrogen for Laboratory Use

**H**YDROGEN for your home-laboratory experiments can be generated from bits of an old kitchen pot or other scrap aluminum and common lye in two tin cans set up as shown in the drawing. For this modified Kipp generator have one can small enough to telescope into the other and leave room for pouring in a lye solution. Notch the smaller can, as shown. Make a tightly fitting disk of wire screening and cut a hole in the screening just large enough to take a bent glass tube. Fit a rubber tube equipped with a pinchcock over the end of the glass tube to lead into the vessel in which the gas is to be collected.

Put aluminum scraps in the smaller can, insert the screening and bent tube, invert this can in the larger one, and hold it down with a weight. Close the pinchcock and pour the lye solution into the larger can until it is nearly full; then release the pinchcock to force out the air.

Be sure all air has escaped before collecting hydrogen in any quantity, for the two combined will explode when ignited. As a test, collect some in a test tube filled with water and inverted in a dish also containing water, and light it with a taper. If the gas pops, air is still present.

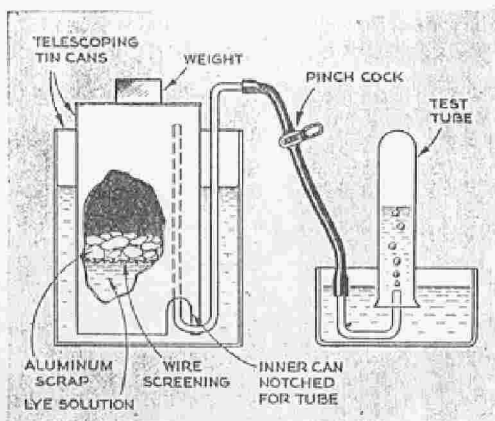



# Paratroop Trapshooter

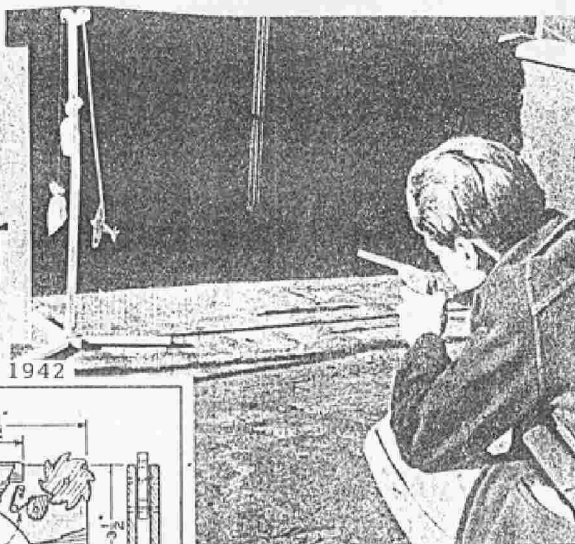

Mechanics Illustrated Dec., 1942

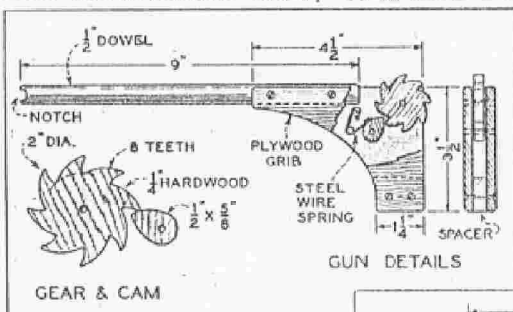

Gravity power turns the target arm of this fascinating game. Little bags of sand of different weights provide the pull on the gravity motor. When the plane is hit by rubber band from gun, it falls.

**T**HIS unique target game may be constructed from various pieces of wood scrap. The only tools necessary beside the usual saw, screw driver, and hammer is a coping saw or jig saw.

The gun provides for eight shots set off in rapid succession. The ammunition used is rubber bands. For the barrel of the gun use a nine inch length of  $\frac{1}{2}$ " dowel. The forward end of this piece must have a very smooth notch about a quarter of an inch deep. Cut the sides to the shape shown in the drawing. Plywood answers this purpose admirably. The most difficult part of the gun is the gear and the cam. The dimensions for both are shown in the drawing. These should be cut from hardwood. They are each  $\frac{1}{4}$ " in thickness. The cam is mounted so that it will catch the teeth of the gear. A piece of spring steel piano wire causes the cam to return to position and

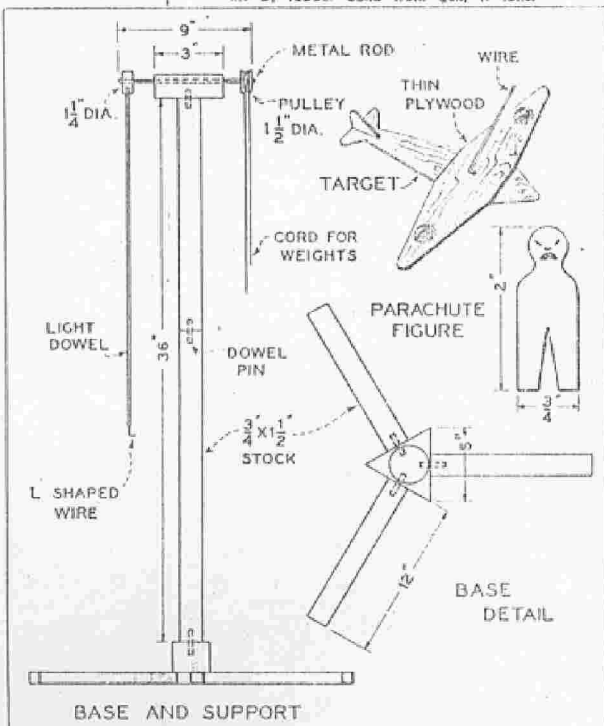



## Paratroop Trapshooter

hold the gear from sliding. The tension of the rubber bands will hold the gear when the gun is loaded.

The gear is mounted so that the teeth protrude over the edge of the top and the back.

A piece of wood  $\frac{5}{8}$ " thick is attached to the bottom part of the handle as a spacer. The dowel used as a barrel is shaved down on the sides to the same thickness thereby providing a spacer at the top part of the sides of the handle, and consequently a recess for the gear and the cam.

To load the gun loop one end of the rubber band over the front end of the barrel, draw it back and place it on one of the teeth of the gear. Then force the gear backward with the thumb. The gear will be held by the cam. This is repeated until the gun is fully loaded. To release the bends it is necessary only to move the gear forward with the thumb. This can be done very rapidly.

The stand for the target consists of a triangular stand supporting an upright. At the top of this is a pulley on one end of a shaft and a circular piece at the other end. A length of light dowel holds the target at the end where there is an L

shaped hook directed inward. When the plane is hit it will naturally slide off the L hook. The centrifugal force of the arm whirling around will keep the plane on the hook until it is hit.

A novel form of power whirls the arm around. Two small bags, one heavier than the other each filled with sand provide a means of turning the arm. The ends of a piece of string are attached to one of the small sand bags. The string is looped over the end of the pulley mentioned above. The weight of the heavier bag moving downward will cause the arm to turn. The lighter bag maintains the tension of the string.

The entire target stand is doweled together so that it may be taken apart easily.

Another novel and interesting target is a small parachute jumper. The parachute is made of paper used to cover model airplanes. A circular piece of this paper is cut in a circle of about twelve inches diameter. Four pieces of string attached to four opposing sides and thence to a small wooden figure completes the parachute.

Popular Mechanics 1947

## Easy Way to Find Specific Gravity of Minerals

It's a simple matter to convert small balance scales of the type used in weighing photographic chemicals so they can be used to determine the specific gravity of minerals, etc. Just suspend a couple of small weighing pans from one end of the scales as indicated. Rimless spectacle lenses make ideal pans as they are already drilled at opposite sides for attachment of soft wire bails. A straight piece of fine, stiff wire may be used to suspend the upper pan. The lower one is hung from the upper one by means of a piece of fine silk thread, which weighs practically nothing. In suspending the pan assembly use a

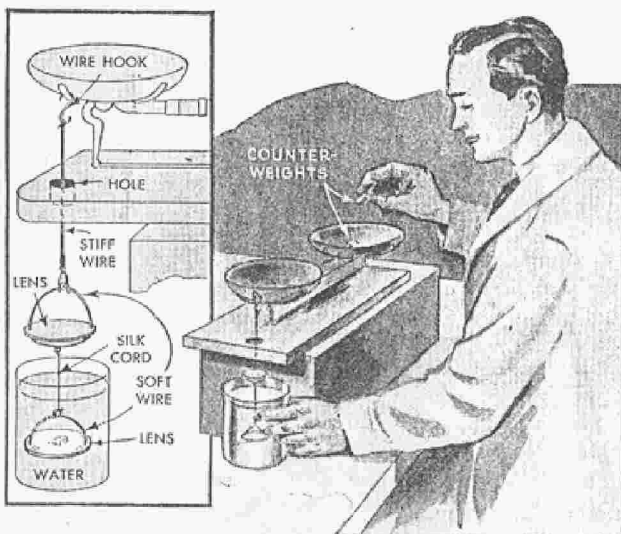

small wire hook and slip it over one of the fingers on the scale, getting it as near the center of the scale pan as possible. Do not hook it over the edge of the pan as this will produce a slight stress in the lower horizontal rod of the scale and make weighing inaccurate. Immerse the lower pan in a glass of water to a depth of about half the

length of the silk thread. Wad a piece of tin foil, or use other weights to balance the scale exactly. Weigh the specimen in the upper glass pan (dry) and then in the lower one (wet). The difference in weight then is divided into the dry weight to give the specific gravity.

Philip H. Grant, Wilmington, Del.

# Table-Top Factories

POPULAR SCIENCE DECEMBER, 1938



MAKING PAPER  
FROM WOOD

The process by which wood is transformed into paper can be demonstrated easily. Particles scraped from a piece of white pine, as illustrated above, are treated chemically, bleached, and washed. Photo at left shows the final step, in which the pulp is poured out onto a wire screen for drying.

By

RAYMOND B. WAILES

THE ancients probably never wrapped their groceries in papyrus—paper made from marsh reeds instead of wood.

There wasn't enough of it. They had no axle grease but "hog lard" for their warriors' chariots. Their pottery was colored with pigments of very few hues.

Today we have almost unlimited quantities of cheap paper; greases and oils of a thousand grades; and brilliant, prismatic-tinted pigments and paints that actually vie with the rainbow in variety and radiance. And there was nothing even to compare with modern plastics among the trinkets that early craftsmen fashioned out of metal and clay.

Have you ever wondered how these newer things are made? Even with the simplest of equipment, in your home laboratory, you can try your own hand at manufacturing them. Your test tubes and flasks will yield materials

that were utterly beyond the power of the wisest men of earlier times to produce.

How to transform wood into paper, for example, would have baffled the ancient papyrus makers. But you can do it easily. A piece of white pine will serve nicely for the raw material. Convert it into fine particles by rubbing it with a rasp. Sift the raspings with ordinary window screen, discarding the fragments that are too large to pass through the mesh. Collect about a teaspoonful of the sifted particles. This operation corresponds to the one called "breaking" or "beating" in modern paper making.

Now boil the raspings for ten to fifteen minutes in a solution made by dissolving about twenty grams of sodium hydroxide, or ordinary lye, in 100 cubic centimeters of water. (For this and other measurements, it may be helpful to recall that a teaspoon

• IN YOUR OWN LABORATORY YOU CAN SHOW HOW

# for Home Chemists

holds about five grams of most powdered chemicals, or three and a half cubic centimeters of a solution; and that the capacity of an ordinary drinking glass is about 240 cubic centimeters.) The caustic solution extracts gums, resins, and other soluble substances, leaving the cellulose of the wood fibers. Pour off and discard the brown-stained liquid, and repeat the boiling with a fresh batch of the sodium hydroxide solution. This extracting process corresponds to the one called "digestion" in a modern paper mill.

To remove the caustic, let the pulp settle in a tall, slim vessel of water, such as a large cylindrical graduate. Wash the pulp by decantation—that is, pour off the top water; add fresh water; let the pulp settle again; and pour off the top water once more. The pulp is now ready for bleaching.

Since chlorine gas will be the bleaching agent, you should perform this operation outdoors. Put the washed wood pulp in a beaker or flask, add enough water so that the layer of pulp comes about halfway to the surface, and let the gas bubble through it. You can make the chlorine by allowing muriatic acid (hydrochloric acid) to drip from a stopcock funnel into a flask holding crystals of potassium permanganate, piping out the gas through the other hole in the two-hole stopper. The set-up is the same that has previously been described in this series for generating gases of many kinds. For a single bleaching "run" or operation,

## COLORS FROM THE TEST TUBE

You can produce brilliant pigments by the same methods that are followed in paint and dye factories. At the right, homemade coloring materials are being filtered out. Note the handy filtering rack in which dowel rods support the funnels and the beakers rest on a glass hand plate of the type used on doors

use from fifteen to twenty grams of potassium permanganate and about fifty cubic centimeters of the acid. This proportion uses the permanganate, the more expensive chemical of the two, to the best advantage.

This completes the first cycle of treatment, but the pulp will not yet be nearly as white as a paper maker would desire. The whole round of operations, therefore, should be repeated three or four times in the same order—"digesting" the pulp with hot caustic, washing it by decantation, and bleaching it with chlorine. Finally the bleached pulp should be thoroughly washed with water, poured out in a thin film upon a piece of wire screen, and allowed to dry.

Your product is a sheet of genuine paper,

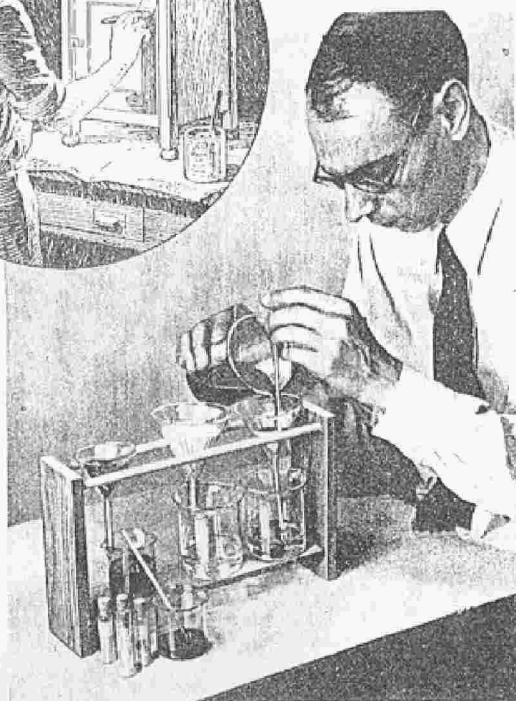
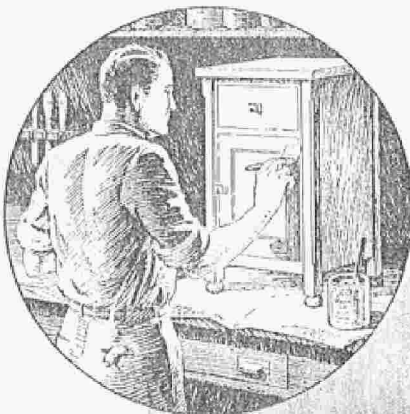

PAPER, PAINTS, PLASTICS, AND LUBRICANTS ARE MADE •

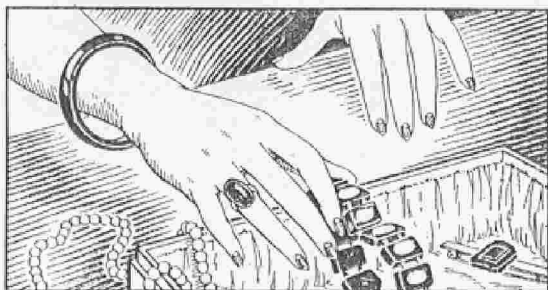

## A GIFT OF MODERN CHEMISTRY

In plastics, man has created new substances that were unknown in the past. With simple equipment and materials you can repeat a historic chemical feat—preparing and molding synthetic resin



Distilling a mixture of ethylene glycol and phthalic acid anhydride to produce a synthetic resin

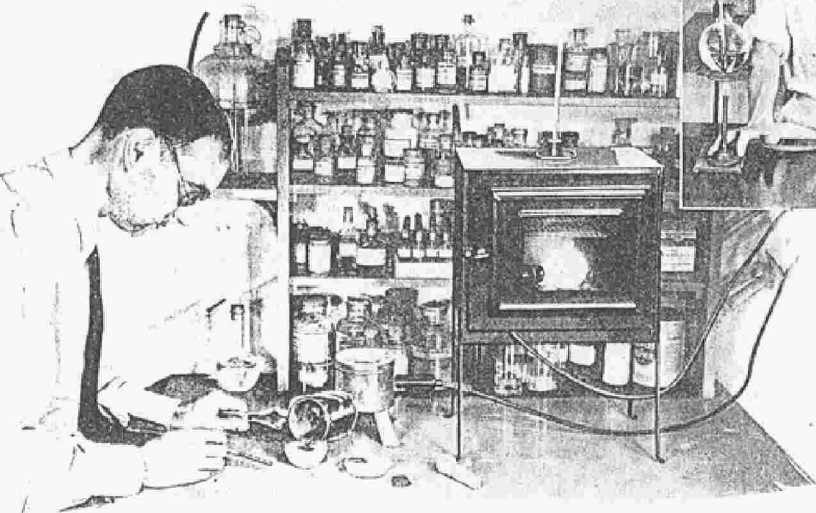

At the left, the plastic is being poured into molds. The oven in the background is used in "curing" it

the "bibulous" type of which blotters and filters are made. It should have a permanent place among the exhibits in your home laboratory, along with the relics of other experiments that serve as milestones in the progress of your hobby.

In commercial paper making, the pulp is screened off in just the same way. By additional steps such as sizing, filling, and calendaring, the paper is adapted for writing purposes.

Would you like to enrich your chemical museum with painted samples of wood, tinted with colorful pigments that you have made for yourself? Though many pigments come directly from the earth, some of the brightest hues originated in the test tube. You will find a number of them surprisingly easy to prepare. Where the strength of a solution is not otherwise specified in the following recipes, use ten grams or so of the chemical, dissolved in about 150 cubic centimeters of water.

To make chrome yellow, mix potassium dichromate solution with a solution of lead acetate or of lead nitrate. Filter off the yellow precipitate. Wash the precipitate well with water while it is still upon the filter paper, and then dry it. The product is lead chromate, popularly called chrome yellow in commercial usage.

A lighter tint may be obtained by dissolving some sodium sulphate in the potassium dichromate solution, before use. Then, when the solution of the lead salt is added, white lead sulphate is formed along with the yellow lead chromate. Filter out the mixed pigment and wash and dry it as before.

Chrome orange or chrome red may be prepared by boiling pure chrome yellow (lead chromate) in a weak solution of an alkali—say, sodium hydroxide or calcium hydroxide. A basic form of lead chromate, with a reddish hue, is the result. Filter out, wash, and dry it.

For Prussian blue, add a solution of potas-

sium ferrocyanide to a solution of ferric chloride or of ferric nitrate. This immediately yields the blue pigment as a precipitate. Or, pour a weakly acidified solution of ferrous sulphate into a solution of potassium ferrocyanide or of sodium ferrocyanide. Filter off the whitish precipitate of ferrous ferrocyanide, and stir it in a beaker of fresh water with about two grams of bleaching powder. Then add hydrochloric acid and boil. This converts the precipitate to ferric ferrocyanide, or Prussian blue. Whichever method of preparation you use, the final procedure of filtering out, washing, and drying is followed.

Cobalt blue will be formed if you make a paste of aluminum oxide with a weak (faint-pink) solution of cobalt chloride or cobalt nitrate, and heat the mixture to a high temperature. A Bunsen or Meker burner, rather than an alcohol lamp, must be used. The longer and more intense the heating, the deeper will be the shade of blue that you obtain. Cobalt aluminate is the chemical name of the pigment.

Brunswick green can be made by mixing, dry, about twelve parts of chrome yellow and one part of Prussian blue.

To make white lead, dissolve twenty grams of lead acetate in 150 cubic centimeters of water. Add fifteen grams of litharge (lead monoxide), and boil the solution. It now contains a soluble, basic form of lead acetate. Filter out and discard any undissolved material. Then bubble carbon dioxide gas through the filtered liquid. You will obtain a precipitate of basic lead carbonate, or white lead,

which should be filtered out, washed, and dried. Carbon dioxide gas for this experiment can be generated in any standard way, such as by the action of hydrochloric acid, diluted with four times its volume of water, upon marble chips or baking soda.

Everyday paints are made from pigments like these by grinding the coloring materials with various oils, thinners, driers, and gums. From any one of the pigments just described, you can make your own paint. First, grind the pigment with a little linseed oil to form a paste. Add a pinch or so of manganese borate powder. Grind the mixture again, and then thin it to the desired consistency with turpentine. Apply your paint to a small panel of wood and allow it to dry for several days.

Even the manganese borate that this recipe calls for may be prepared in your own laboratory. Add a filtered solution of borax to a solution of manganese chloride or of manganese nitrate. The resulting grayish-pink precipitate of manganese borate is washed and dried for use.

As if by magic, you can change ordinary motor oil into stiff cup grease. All you need do is to heat about ninety grams of the oil, or a little less than half a tumblerful, with ten grams of aluminum stearate powder. Stir the mass until it becomes clear. Then let it cool slowly without further stirring. It will form a thick, transparent grease. You can demonstrate its stiffness by placing a heavy weight in it. The weight remains suspended, instead of dropping to the bottom. Lubricants of the type (Continued on page 248)



#### GREASE FROM COMMON LUBRICATING OIL

Motor oil is transformed into stiff cup grease by heating it with aluminum stearate powder and allowing it to cool slowly. The resulting grease is so stiff that a weight placed in it remains suspended on top, as shown above. Lubricants of the type known as "aluminum-soap greases" are made in this manner



known as "aluminum-soap greases" actually are made in just the way you used.

Casting duplicates of small objects in synthetic resin offers one of the greatest thrills that await an amateur chemist. You can repeat a chemical feat that made history, by preparing and molding the resin almost exactly as the pioneer in the field of plastics, Dr. Leo H. Baekeland, did it some thirty years ago. For the experiment you will need a supply of formaldehyde solution of about thirty-seven-percent strength, the usual type sold; and of phenol, or carbolic acid, in its pure, solid form—not the solution which is used as an antiseptic. Like such common household substances as iodine, lye, and ammonia, phenol is a poison, but may be handled perfectly safely with reasonable care.

Immerse a bottle of phenol in hot water to melt the contents. The crystals liquefy above forty-three degrees centigrade (109 degrees Fahrenheit). When they have done so, weigh out 100 grams of the liquid phenol in a beaker of about 300-cubic-centimeter capacity. Add fifty cubic centimeters of the formaldehyde solution; then a gram of sodium hydroxide or potassium hydroxide, which has been dissolved in about three cubic centimeters of water, to serve as a catalyst, promoting the reaction. The rest of the experiment must be performed outdoors, unless your laboratory has a hood that can be used for drawing off the formaldehyde fumes, as they cannot be tolerated in a room.

Heat the brownish liquid in the beaker to a gentle boil. Keep it at this temperature until, after about twenty minutes, the entire contents becomes thick like cold molasses. You will have no trouble in judging this point, as you will notice the sluggishness with which bubbles break through the hot liquid. This is the time to pour it into molds.

You can use a test tube or a small bottle as a mold, or you can make small plaster-of-Paris molds of more elaborate shapes. These should be prepared in advance by pressing small objects such as a radio knob or the head of a small doll into the wet plaster, and allowing the plaster to harden.

After you have poured the resin into the molds, the castings must be "aged" or heat-treated. The purpose of this treatment is to make them firm, infusible, and insoluble. Place the filled molds in a closed box that will serve as an oven. The drying oven described in a previous article in this series (P.S.M., Oct. '38, p. 206) is well-suited for this part of the experiment, when a lamp of from sixty to 100 watts is placed within it as a source of heat. Heat the castings for four hours at a temperature of about sixty degrees centigrade, or 140 degrees Fahrenheit; and then for four hours or more at about seventy degrees centigrade, or 160 degrees Fahrenheit. When this has been done and

you remove the castings from the mold, they will be transparent and tinted the color of sherry wine.

If you age the castings for the minimum time specified, they will still yield somewhat under heavy pressure, but should retain their form for some months at least. They will be more durable if you continue the heat treatment for several days; and even a week is not too long.

Some variations in this method—which, like those that follow, is to be regarded purely as experimental and not intended to produce practical or salable castings—are introduced in commercial practice. After the hot, viscous liquid has cooled, it is ground and mixed with a filler. Then, with the aid of heat and pressure, it is molded into pipe stems, radio parts, handles, and knobs.

Another modern commercial product is a varnish made from synthetic resin. You yourself can demonstrate the way that such a varnish is prepared by dissolving in acetone some of the resin that remained in the beaker.

To clean the beaker after these experiments, immerse it completely in a tin can filled with a solution of sodium hydroxide (lye), and boil the solution.

A second type of synthetic resin can be made indoors. Heat sixty grams of pure ethylene glycol and 150 grams of phthalic acid anhydride in a flask that is fitted with a condenser. A thermometer should be placed so that its bulb dips into the contents of the flask. At a temperature of about 183 degrees centigrade, or 370 degrees Fahrenheit, the mixture will liquefy completely. As you continue heating, water distills over, and should be discarded. When the temperature reaches about 210 degrees centigrade or 410 degrees Fahrenheit, the hot, stiff liquid in the flask—now a synthetic resin—is ready to be poured into molds. Like the other type of synthetic resin, this one should be "cured" or aged in an oven to make it infusible and insoluble, and the same details of the treatment apply in this case. The transparent castings made from this resin will be clearer than wax.

Uncured resin left in the flask may be dissolved in acetone or other solvents to make an experimental varnish. You can clean the flask of any viscous residue that remains by heating in it a mixture of equal parts of sulphuric acid and water, together with some potassium dichromate or sodium dichromate.

With the set-up just described, you can make still another resin—this time, a black one resembling tar. Heat in the flask 250 grams of phenol, 175 grams of ordinary thick glycerine, and five cubic centimeters of strong sulphuric acid, keeping the temperature between 160 degrees and 190 degrees centigrade (or 320 degrees and 375 degrees Fahrenheit). Water and liquid phenol will



## Table-Top Factories

collect in the receiver of the condenser. From time to time, pour back the lower layer of liquid phenol from the receiver into the reaction flask. When about fifty cubic centimeters of water have been distilled over, cool the flask slightly. Stir in about five grams of precipitated chalk or calcium carbonate to neutralize the acid. Then pour the contents of the flask, while still warm and fluid, into molds and carry out the curing or heat treatment as with the other types of resin.

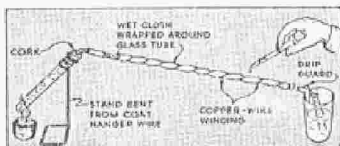

### Lab Still Uses Odds and Ends

In a few minutes you can put together the little distilling setup shown above, which is entirely satisfactory for many home-lab purposes. The wet cloth wrapped around the long tube will provide almost as much cooling as tap water circulating in a water jacket. Be sure to use a guard to keep the drip from the condensate. Don't apply heat too fast or unevaporated solution may bubble into the line. A few short pieces of glass tubing in the first test tube will keep big bubbles from forming. You'll find that an ordinary medicine dropper will provide a handy and controllable way of supplying water to the cloth.—JOHN L. STONY.

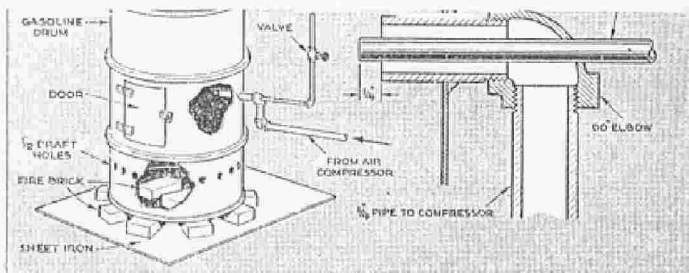

### Homemade Shop Stove Burns Crankcase Drainings

This efficient oil stove, which uses old crankcase drainings as fuel, has for several winters provided cheap heating of a good-sized repair shop. Compressed air from the shop air line "atomizes" the fuel and gives a steady, hot flame.

A 55-gal. drum, fitted with a door and a stovepipe chimney, serves as the body of the stove. The bottom is covered inside with firebrick, and a ring of bricks elevates the drum from the floor. The air nozzle consists of a short length of 3/4" pipe welded

to the drum. Inside it and protruding 3" farther is the 3/4" fuel-supply pipe. Valves in both lines permit adjusting the stove for best combustion and the desired amount of heat. The oil reservoir, located some distance away for safety, feeds the stove by gravity. To start it, the stove is warmed by burning newspapers inside, and then the oil and air lines are slowly opened. If possible, use a long run of stovepipe to get the maximum radiation, fitting it if necessary with a device to check down drafts.—C. F. STRAIN.

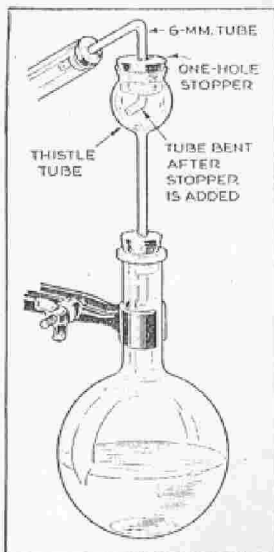

### Home-Lab Distilling Flask

IF YOU have no long-neck Kjeldahl flask for distillation purposes, you can improvise one from an ordinary short-neck flask, a thistle tube, some one-hole rubber stoppers, and a length of 5 or 6-mm. glass tubing. Insert the tubing in a rubber stopper that closes the thistle tube, bend it to the shape shown at left, and set the tube in the flask as indicated.—DONALD R. RANDELL.

### Fluorescent-Tube Condenser

SATISFACTORY condensers can be made from burned-out fluorescent-light tubes. Cut the ends off and smooth them in a Bunsen flame, and then stopper both ends with two-hole cork or rubber stoppers in which glass tubing is inserted as shown at right. The coolant is flowed through one of the short tubes and out of the other, while the gas or vapor being condensed is flowed slowly through the long tube into a collecting receptacle.—MORRIS LIGHTFOOT, JR.





# magic garden

*Photos by Lester, Camera Click*

**Dissolve a few chemical salts  
in waterglass and—presto!**

*Mechanix Illustrated  
April, 1946*

**C**HEMICAL magic in one of its most spectacular forms can be practiced by any amateur who will borrow a leaf from his high school "chem" book and conjure up a few "crystal gardens."

These aren't difficult to make, and require no more material than the necessary chemicals, a good size aquarium and enough sand or fine gravel to cover the bottom to a depth of about 1 inch. The aquarium is filled with a solution of waterglass (sodium silicate), and the chemicals are dropped in it. As they settle to the bot-

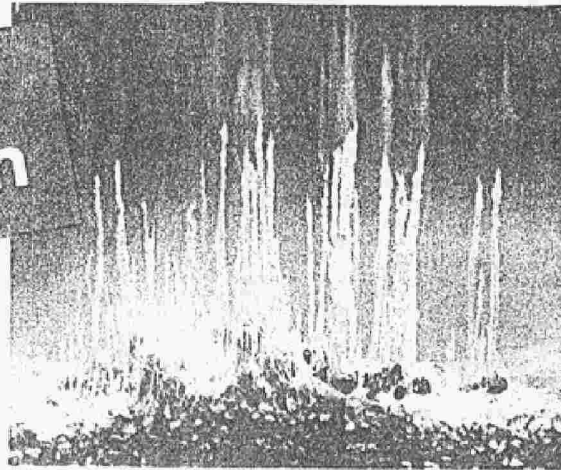

A few minutes after the sulphate crystals are added to solution, green streamers begin to appear.

tom, they grow into a colorful pattern of intertwining clusters which might resemble a submarine forest in some as yet unexplored deep.

The waterglass may be of any strength. If you can get the kind which is used to preserve eggs, dilute with its own volume of water. The salts you can use are any of the salts of nickel, iron, cobalt, copper, etc., such as the sulphates, chlorides or nitrates. Many of them can be obtained at your local drugstore. The action is as follows: as the salt crystal dissolves, it



Chemicals used to form garden shown here were ferric chloride (for brown) and nickel sulphate (for green). Crush crystals; add mixed or separately.



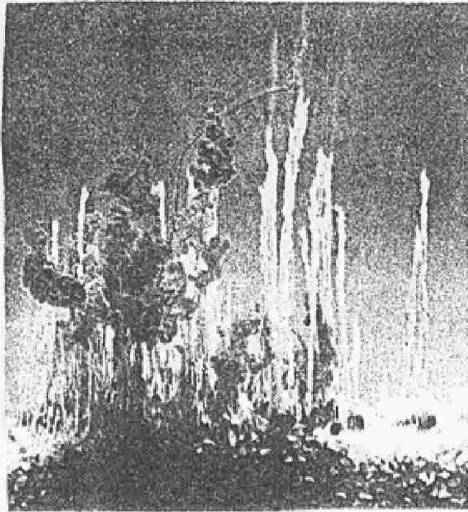

The brown ferric chloride has been added and the new growth starts to appear.

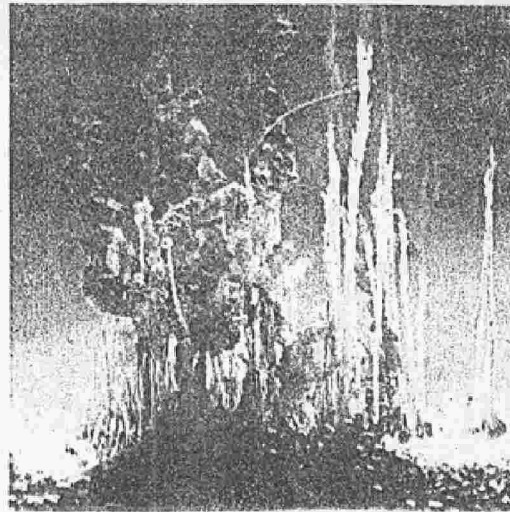

Garden continues to expand slowly but fast enough to be observed under hand lens. It is 20 min. old in pic below.

forms a silicate of the original metal. By osmosis, this compound keeps absorbing the water from the waterglass and swells up, increasing in size until the entire salt has been changed into the silicate. This latter is the material of which your magic garden is composed.

No two gardens are alike, as the growth shape of the silicates depends upon their internal structure. The suggested chemicals need not be used singly, but may be added to the solution separately or in a mixture to form color combinations. The average time to grow is about one-half hour, but frequently a garden will keep on growing almost indefinitely until it threatens to fill the entire aquarium. Sometimes, when observed under a high-power magnifying glass, the actual expansion of the silicate can be noticed.

For best results, use chemicals sparingly; avoid excess quantities which cause nothing more than a jumble of color. Be sure not to disturb your garden during or after growth. Interesting results can be obtained by "growing" a number of small colored gardens in tall glasses for shelf ornaments.

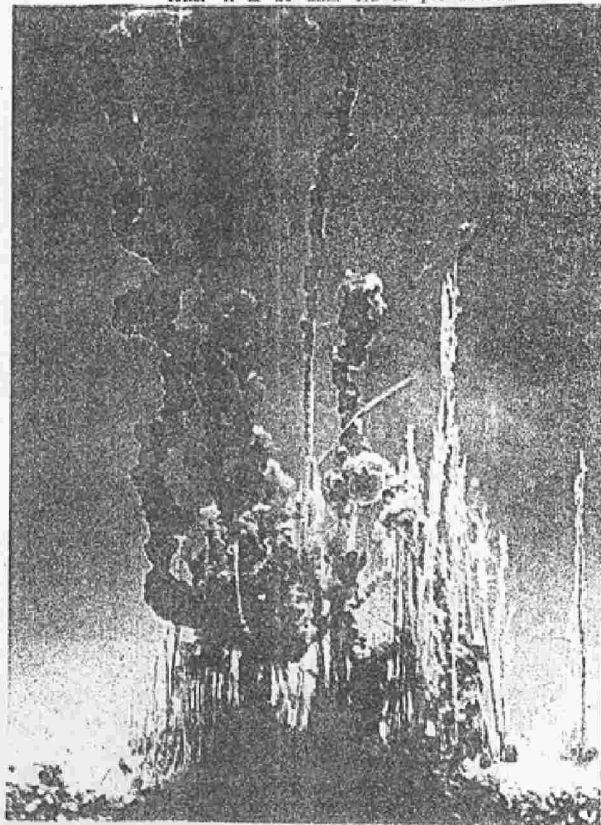

# Chemistry Predicts How Metals Will Act

POPULAR SCIENCE JANUARY 1948

By **Kenneth M. Swezey**

**S**NAP on a flashlight, and you start a chemical reaction that produces electricity, heat, and light. Turn on the current in an electroplating tank, and electricity does a chemical chore, depositing a film of metal molecule by molecule. What is the link between test tube and electric spark? In large part it is found in the reaction of metals with other substances.

When a small piece of potassium or sodium is placed in plain water, the metal reacts violently with the water, releasing hydrogen so furiously that the gas often catches fire. Magnesium won't release hydrogen from cold water, but it will from hot water. Aluminium, zinc, iron, and tin can't displace hydrogen from water, but can

from acids. Copper, silver, platinum, and gold won't set hydrogen free even from acids.

By elaborate tests, chemists have arranged all metals in a list according to the ease with which they enter into chemical reactions. This list, shown on the facing page, is variously called the activity series, the electromotive series, the electrochemical series, or the displacement series, depending upon the use for which it is intended.

Potassium, the most active metal, stands at the top; gold, the least active, at the bottom. Hydrogen acts much the same as a metal in displacement reactions and so is included as a guidepost. Any metal above hydrogen is more active than hydrogen, and so will displace this gas from such acids as sulphuric and hydrochloric. Metals below

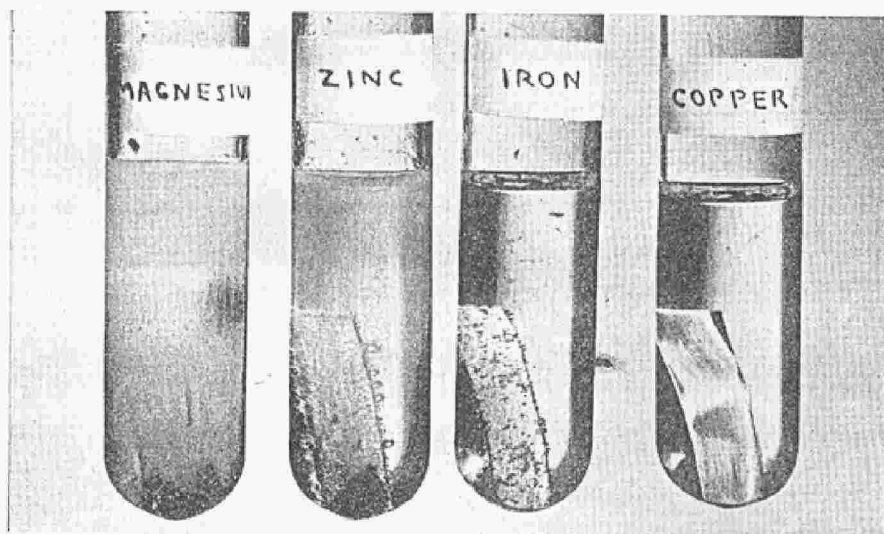

Relative activity of the common metals may be determined roughly by the rate at which they liberate hydrogen from acids. Here, pieces of four metals are placed in dilute hydrochloric

acid. Magnesium releases bubbles of hydrogen violently, zinc less rapidly, and iron rather slowly. Copper, located below hydrogen in the activity series, does not release it at all.

hydrogen cannot displace it from any of the acids.

To impress this on your mind, you can make a visual demonstration. Add one part of hydrochloric acid to four parts of water and pour an equal amount of the diluted acid into each of four test tubes. Into one tube drop a piece of freshly polished copper, into the next a similar piece of iron, into the third a piece of zinc, and into the last a bit of magnesium. The magnesium reacts so strongly that the acid literally boils. Zinc releases bubbles a little less rapidly, iron displaces the gas rather slowly, copper not at all.

Another principle to be learned from the activity series is this: When any metal is placed in a salt of a metal that stands below it, the first metal is dissolved and the second is thrown out of solution. You can prove this in one instance by means of a color change. Dissolve some copper sulphate in water, and the copper ion will color the solution blue. Now add a little zinc dust and stir the solution thoroughly. If enough zinc has been added, the blue color will disappear. The zinc ousts the copper from the copper sulphate and joins with the sulphate radical to form zinc sulphate—which, in solution, is colorless. Red metallic copper

### ACTIVITY SERIES

Metal	Chemical symbol		
Potassium	K	} More active than hydrogen.	
Sodium	Na		
Calcium	Ca		
Magnesium	Mg		
Aluminum	Al		
Zinc	Zn		
Chromium	Cr		
Iron	Fe		
Nickel	Ni		
Tin	Su		
Lead	Pb	} Acting much like a metal in displacement reactions, this gas is included as a guidepost.	
Hydrogen	H		
Copper	Cu		} Less active than hydrogen.
Mercury	Hg		
Silver	Ag		
Platinum	Pt		
Gold	Au		

also settles to the bottom of the beaker.

Immersion plating of one metal on another is accomplished by this changing of places of metals. Iron, for example, can be given a thin plating of copper by immersing it in a solution of 7 grams of copper sulphate and

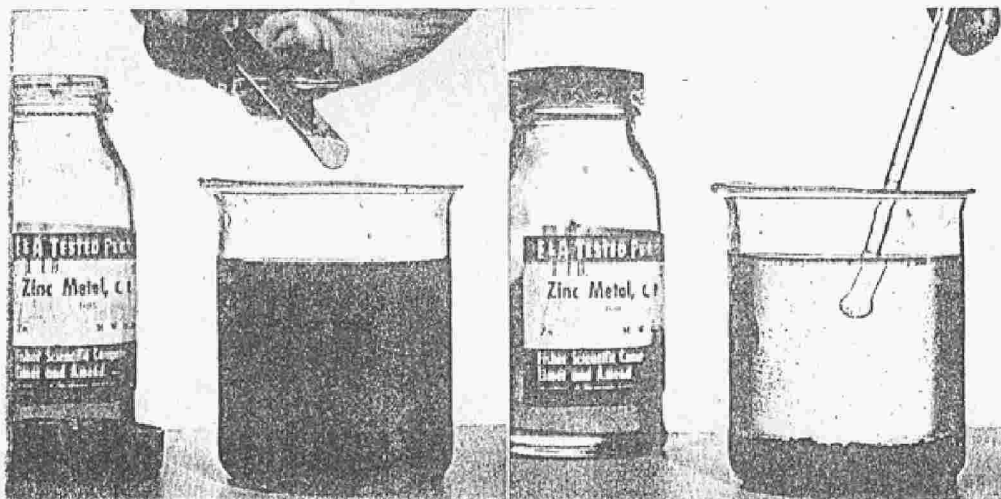

If a metal is placed in a solution of a salt of a metal below it in the series, the first dissolves, the other is thrown from solution. Add zinc dust to a copper sulphate solution and

stir. The blue solution soon clears and red metallic copper is precipitated. The zinc ousts copper from the sulphate and joins with the sulphate radical, forming zinc sulphate.



**Immersion plating** of one metal on another is possible because the metals change place. If iron is put in a solution of copper sulphate and sulphuric acid, copper will be deposited.

3.5 ml. of sulphuric acid in 500 ml. of water. A little iron changes place with some of the copper in the copper sulphate, and the displaced copper adheres to the iron. Only a light plating can be applied by this method. Prolonged immersion produces a spongy deposit that falls off.

Aluminum pots and pans in the kitchen are often darkened by the swapping of metals. If you cook oatmeal, spinach, or other iron-containing food in an aluminum pot, some of the aluminum changes places with some of the iron, the latter being deposited as a dark coating inside the pot. Although the neat housewife may scour away this deposit, she needn't do so, for the

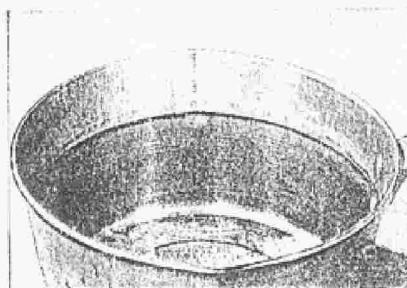

Aluminum pots often are darkened by deposits of iron from certain foods, the iron replacing some of the aluminum. The iron may be removed harmlessly by cooking acid foods.

iron will be removed chemically if some acid food such as tomatoes, rhubarb, or sauerkraut is later cooked in the pot. The iron thus regained is harmless and a valuable food mineral.

A more specific way to express the activity of metals is to say that they vary in ability to ionize, or give up electrons. Metals at the top of the list give up electrons more easily than those at the bottom. This difference makes electric batteries possible and explains corrosion and electrolytic action between touching metals.

If two metals of different activity are immersed in a suitable solution (electrolyte) and then connected by a wire, electrons will flow through the wire from the most active metal. The farther apart the metals in the series, the greater will be the electromotive force, or voltage.

A similar electrical effect accounts for the accelerated corrosion that often takes place when two metals are in contact in the presence of moisture. An electric current is set up, causing the more active metal to dissolve more rapidly than normal, while at the same time the less active metal is preserved from corrosion.

You can demonstrate this. Wind a short length of iron wire tightly around a piece of zinc, a similar wire around a piece of tin foil, and immerse these metal combinations in separate glasses containing dilute sulphuric acid (2 drops to 100 ml. water) with enough potassium ferricyanide to color the solution pale orange.

Quickly, the solution in the glass containing the foil-iron begins to turn blue, indicating that iron is dissolving and uniting with the ferricyanide. The other solution turns only faintly blue, if at all, for the zinc, being more active than iron, dissolves in place of it. This explains why the iron in "tin cans" corrodes more rapidly when the tin plating is broken than if it were not plated at all. It also explains why the iron in zinc-plated, or "galvanized" iron, is protected when the zinc coating is damaged. In the latter case, the zinc—being more active than the iron—dissolves, and in doing so forms a protective coating over the iron.

Solutions and "magic" plates or containers of aluminum that are sold to clean silverware without scouring depend upon an exchange of metals. Ordinary baking soda (sodium bicarbonate) and salt (sodium chloride), plus any aluminum pan, will

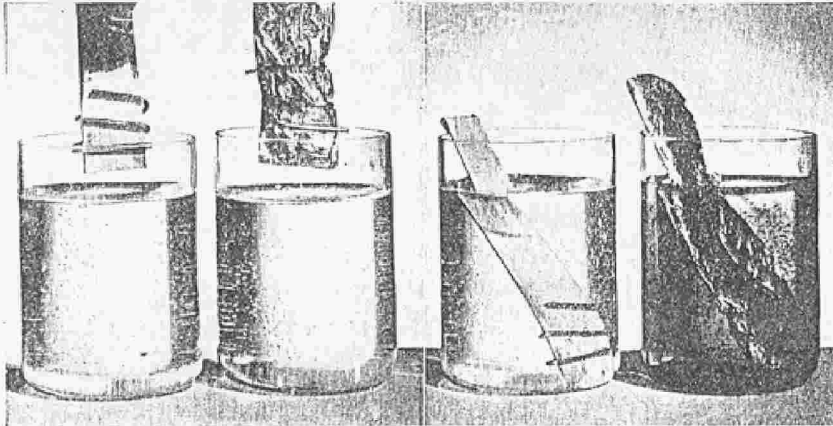

When two metals of different activity are in contact with each other in an electrolyte, an electric current is set up, causing the more active to go into solution more rapidly than

it normally would. This may be demonstrated by winding iron wire around zinc and tin foil and then immersing each combination in dilute sulphuric acid and potassium ferricyanide,

enable you to work the same magic. Place the silver so that each piece touches the pan. Cover with a hot solution of 1 teaspoonful of soda and another of salt to each quart of water. After several minutes, remove the silver, rinse, and polish with a soft cloth.

Touching the aluminum and surrounded

by the electrolyte, the silver forms one plate of an electric cell. By action of this cell, the tarnish of silver sulphide is dissolved. Then the sulphur is ousted and the silver is redeposited. The method should not be used on "French finish" silver, for it may alter the finish as well as clean the surface.

END

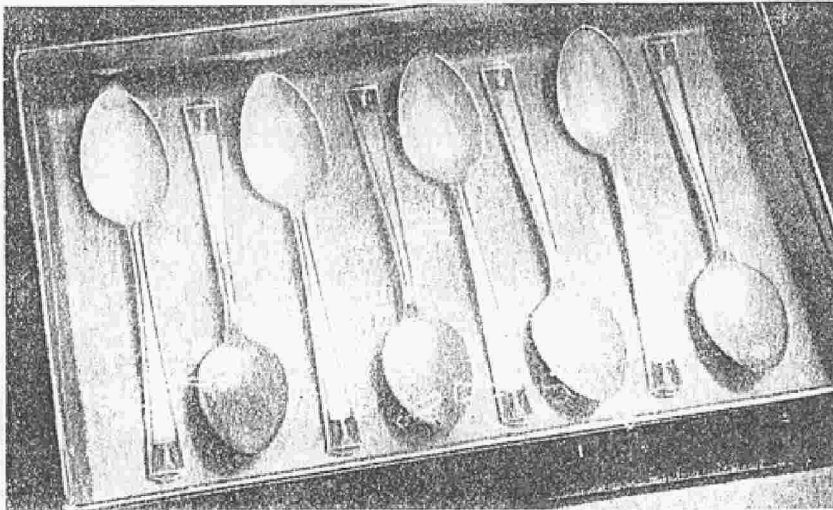

If silver is covered with a hot solution of salt and baking soda in an aluminum pan, an

electrolytic action takes place. This cleans off the tarnish without removing any of the silver.

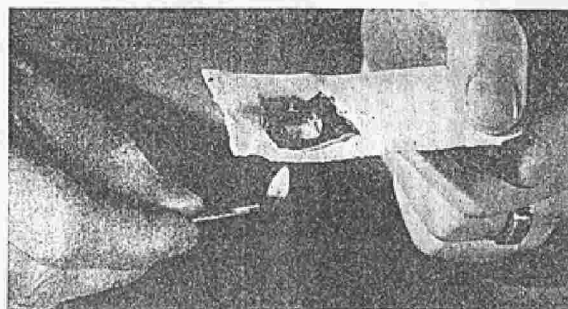
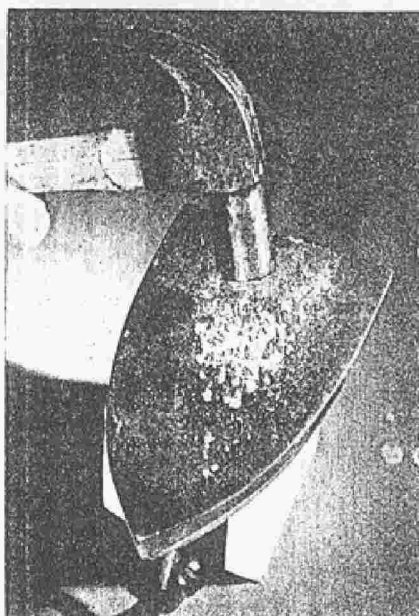

**HOME EXPERIMENTS REVEAL STRANGE**

**TIN IS SO BRITTLE** at 200 deg. C., only 32 deg. below its melting point, that it turns to powder when pounded. You can demonstrate this, as at the left, by heating a flatiron hot enough so that a piece of tin foil melts when placed on its upturned face, then striking the metal occasionally with a hammer as it cools and solidifies. At one point, the tin will shatter into a powder when struck. Another interesting characteristic of tin is that it can be melted on paper without igniting the latter, as shown above. Smooth out a piece of foil on thin paper and hold a match under it, without touching the paper, until the metal liquifies. The foil conducts heat from the paper so rapidly that it does not burn.

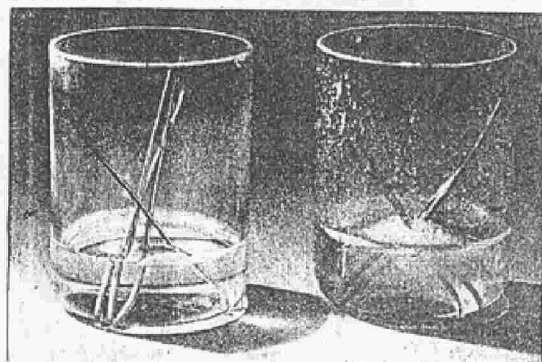

POPULAR SCIENCE OCTOBER, 1945

**IRON DISAPPEARS** quickly when placed in dilute sulphuric acid, but if dropped into the concentrated acid, as shown at the left above, virtually nothing happens. This is explained by the fact that the concentrated acid acts as an oxidizing agent, quickly coating the iron with an oxide that resists further reaction, while the diluted acid reacts vigorously, liberating hydrogen and forming iron sulphate in solution. Because of this property, the concentrated acid can be transported in steel tank cars, and cast iron or steel vessels are used in the final stages of its manufacture.

**METALS EXPAND** unequally. This may be shown by cutting a strip from a tin can (this is really tin-coated iron or steel) and riveting it face to face to a similar strip cut from copper, brass, zinc, or aluminum. When grasped with tongs and held in a candle flame as shown below, this compound strip gradually curls inward toward the side faced with the tin plate. Why? Because the thermal expansion of iron or steel is less than that of the other metals. The second metal, expanding more, forces the bar to bend.

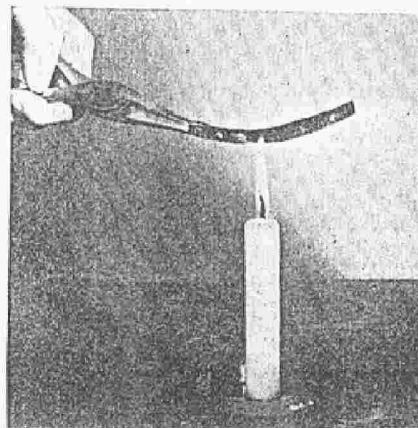



## FACTS ABOUT METALS

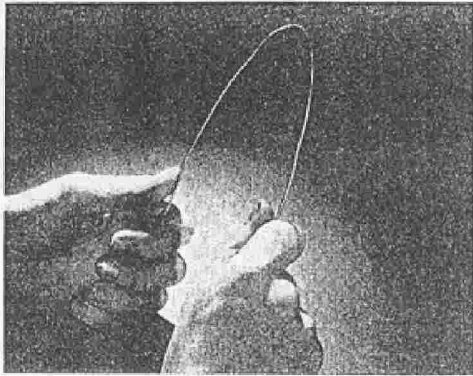

**COPPER HARDENS** when it is hammered. It might seem that this soft metal would become softer still if subjected to pressure, but such is not the case—as this simple experiment will show. First, anneal a piece of stout copper wire by heating to redness and letting it cool slowly. If you now grasp the ends and pull them together, the wire will bend sharply in the middle. There is

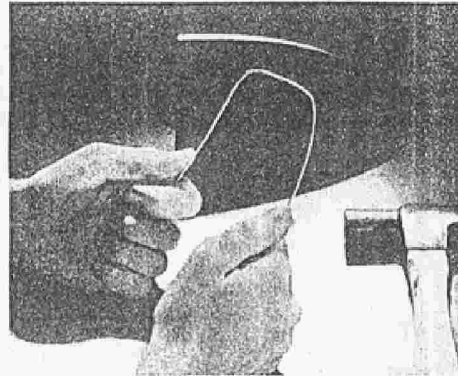

an entirely different result, however, if the wire is straightened and several inches of the center hammered on a flatiron or an anvil. This time the wire doesn't bend in the middle—but at the two ends of the hammered portion. This part has now become too hard and stiff to bend with ease. When copper must be hardened commercially it is subjected both to hammering and rolling.

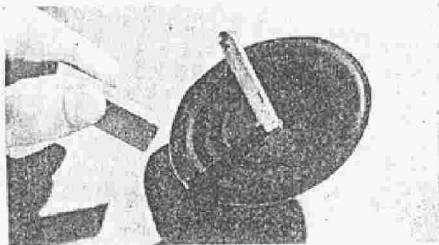

**PARADOXICAL TOP.** Made by thrusting a pointed stick or pencil through a hole in the center of a tin can cover, the top at the left doesn't always react in the way you might expect when a magnet is placed near it. Actually tin-plated iron or steel rather than tin, the cover is attracted by the magnet while at rest. But set it to spinning—and it is sharply repelled. This repulsion is caused by a countermagnetic force produced by eddy currents set up in the top.

**MAGNETIC LIQUID.** Everyone is familiar with the way magnets attract iron, steel, and, to a lesser degree, nickel and a few other metals. But few realize that certain liquids also react the same way. You can easily prove that they do by using a strong solution of iron chloride. Ordinarily crystalline, this chemical has a tendency to deliquesce—melt away in water drawn from the air. Allow a small crystal to remain in the open until this happens. Then tie a tiny loop on the end of a piece of thread and use it to pick up the drop of concentrated iron chloride solution. If you now hold one of the poles of a strong bar or horseshoe magnet close to this drop as it dangles at the end of the thread, you will find that a prompt and definite attraction occurs.

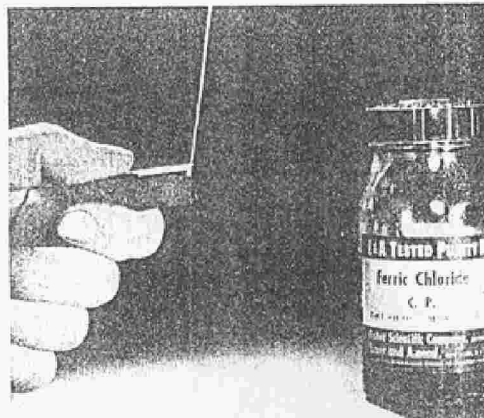



**TASTE AND SMELL** frequently play us false. Grandmother knew exactly what she was doing in holding her children's noses while they swallowed the castor oil, and science now recognizes the fact that the taste of many things is attributable largely to their smell. For example, if a pear is held close to the nose while an apple is being eaten, the apple will seem to taste like a pear.

POPULAR SCIENCE JANUARY, 1946

**SIGHT** often may be unreliable because of optical illusions. Arrange three toothpicks in a line as below. Then ask someone to place a fourth so it forms part of the opposite side of an imaginary square. A ruler will show that most persons misjudge it by a good deal. The usual error is to underestimate the distance and drop the toothpick too close.

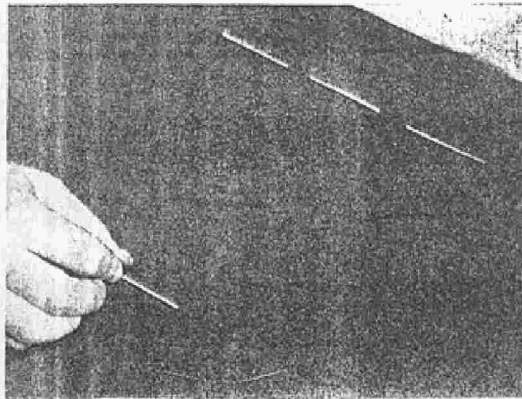

## YOU CAN'T HOME EXPERIMENTS WITH

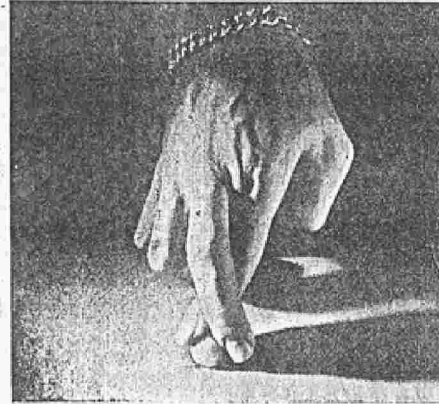

**TOUCH** a marble with crossed fingers as above, close your eyes—and confusion begins. Although you know there's only one marble at your fingertips, your senses try desperately to convince you there are two. This illusion, which incidentally was noted by Aristotle, results because in everyday experience pressure on the outer sides of adjoining fingers indicates two objects.

**SOUND** sometimes gets mixed up with the sense of touch, as this experiment will show. Rub your fingers lightly over the back of a friend's coat while vigorously brushing your own—and your friend will give you sincere thanks for brushing *him* off! The feel of your fingers combined with the sound of the brush conveys to the friend the perfect illusion that he's the one getting the brush-off.

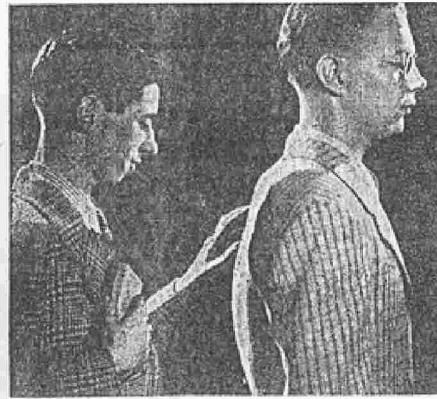

# TRUST YOUR SENSES!

SENSORY PERCEPTION SHOW WE MAY OFTEN BE FOOLED

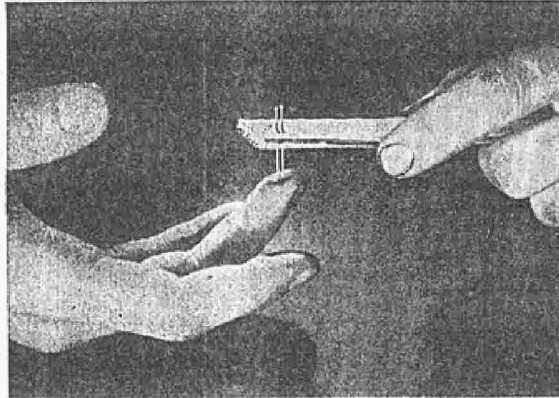
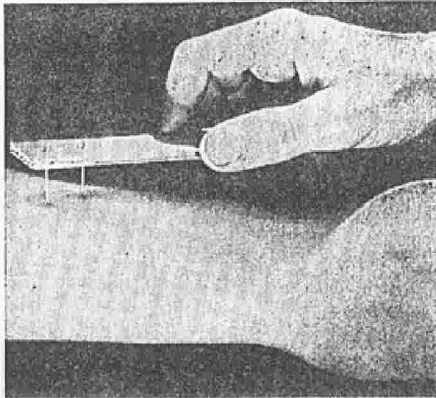

**TOUCH SENSITIVITY** varies on different parts of the body's surface because nerve endings are distributed in varying concentration. On the fingertips the nerve endings are closely packed, and on the lips and tongue they are still more concentrated. But on parts of the body where great sensitivity is not needed, the nerves are comparatively scattered. If you thrust two pins through a

strip of heavy cardboard about 1" apart and touch a blindfolded person on the arm, as at the left, he will say that the point of only one pin touched him. But move the pins close together as at the right and touch his fingertip and he will note immediately that there are two. On some parts of the body, the thigh for instance, pin pricks as much as 2" apart may be interpreted as one.

**HOT OR COLD?** What we think we feel often is governed by what we see. For instance, without the help of our eyes we may not know whether an object is hot or cold. If you are not convinced, touch a piece of ice to the back of someone's neck while in a group of smokers. The victim's angry expostulations that he was burned with a cigarette should be sufficient proof.

**SOUND DIRECTION** usually can be determined because the ear nearest the source receives a louder impression. But when sound reaches both ears with equal intensity from a point above, in front, or behind, the directional sense is poor. A blindfold test will show this. Snap your fingers above, in front, or back of the blindfolded person. Often he won't know the right direction.



# HOME EXPERIMENTS

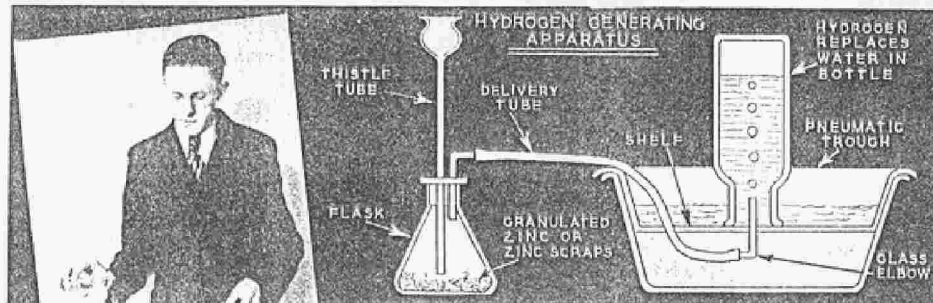

This simple generating apparatus is all the equipment you need to produce Hydrogen gas. Scraps of zinc are placed in flask containing dilute sulphuric acid. Rubber stopper, thistle tube and tubing to pneumatic trough are connected as shown.

*Modern Mechanix* October, 1936  
by VERNON TRACEY

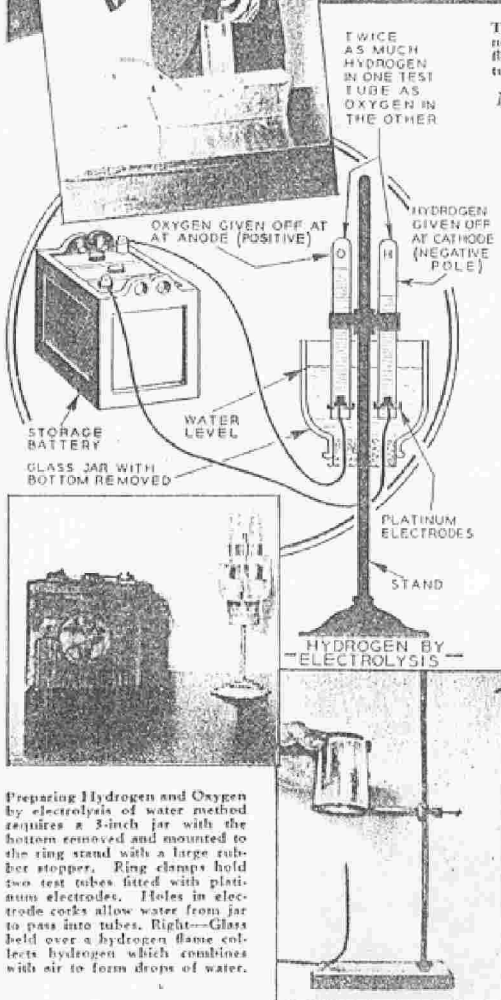

Preparing Hydrogen and Oxygen by electrolysis of water method requires a 3-inch jar with the bottom removed and mounted to the ring stand with a large rubber stopper. Ring clamps hold two test tubes fitted with platinum electrodes. Holes in electrode corks allow water from jar to pass into tubes. Right—Glass held over a hydrogen flame collects hydrogen which combines with air to form drops of water.

**H**YDROGEN, the lightest of chemical elements forms a very interesting field of experiment for the home chemist. It can be produced easily in several ways for experimental purposes; one of the most common of which consists of the action of sulphuric acid on zinc.

A flask into which is dropped a few grams of zinc scraps is fitted with a rubber stopper, thistle-tube and delivery-tube as shown in the photo. The thistle-tube is fitted into the stopper so the end will be about  $\frac{1}{8}$ " from the bottom of the flask. The end of the delivery-tube is near the top of the flask. Dilute sulphuric acid is poured down the thistle-funnel and hydrogen is produced when it comes in contact with the zinc. The top of the thistle-funnel is covered with a piece of glass to prevent the hydrogen from escaping. The hydrogen flows out through the delivery-tube and is collected in a bottle over the pneumatic trough.

If, after some hydrogen has been collected the action slows down, remove the glass from the thistle-tube and add more dilute acid. In diluting the acid, use equal volumes of acid and water and pour the acid slowly into the water while it is being stirred with a glass stirring-rod, for if the water is poured into the acid, steam will be generated and the acid splattered in all directions.

Another even more interesting way of

# WITH HYDROGEN



Hydrogen Peroxide, a common household antiseptic, can be prepared by mixing dilute sulphuric acid with barium dioxide. The resulting milky liquid is cleared by filtering. Before using test the solution to determine whether or not it will successfully bleach cloth.

producing hydrogen is by the electrolysis of water—that is using electricity to break water up into its elements—hydrogen and oxygen. Hydrogen and oxygen are both produced by this experiment and are collected separately.

Fit up a glass vessel on a metal stand as shown in the drawing, fill vessel and test-tubes with acidulated water and support the test-tubes in an inverted position so their open ends will be under water and over the electrodes. Connect the battery and the hydrogen will collect at the cathode, rise up and displace the water in the test-tube. Oxygen will collect in a similar manner over the anode. Because water is composed of two parts of hydrogen to two parts of oxygen, there will be twice as much hydrogen in one tube as there is oxygen in the other. After the hydrogen tube is full, remove it and place it upright in a test-tube rack with a piece of glass over its mouth to keep the gas from escaping. Collect another tube of hydrogen, and by this time the other test-tube will be full of oxygen.

Wrap a towel around a test-tube of hydrogen and holding it mouth down, bring a lighted match up to it. The hydrogen will burn with a pale-blue flame as it leaves the test-tube. Thrust the match up into the test-tube and it will appear to go out, but as soon as it is removed it will flame up again.

Hydrogen burns to form water. This can



Many experiments can be performed with the Hydrogen gas generator described on opposite page. Above is shown model airship constructed of light rubber being inflated with the gas. Pipe connected to generator will blow floating soap bubbles.



A screw cap jet provided with wick and filled with alcohol provides a handy lamp for bending glass tubing into the various shapes required for performing these and other experiments.



be demonstrated by burning a jet of hydrogen and collecting the water-vapor given off. To do this—make a right-angle bend in a piece of copper tubing and mount it on a ringstand.

Loosely pack the top end of the tube with steel-wool to prevent the flame from following the tube back to the generator. Connect the rubber tube from the generator onto the bottom end of the copper pipe and light the hydrogen issuing from the top. If a cold dry glass is supported over the flame, the vapor will condense forming water droplets on the inside of the glass.

Hydrogen and oxygen combine in the proportion of two parts of the former to one part of the latter to form water. They combine however in equal proportions to form hydrogen peroxide—a

well known disinfectant. Oxygen is responsible for the disinfecting properties of this compound. Hydrogen peroxide being a very unstable compound breaks down into water and oxygen when applied to a wound, or even exposed to bright light; thus the necessity for keeping it in dark colored bottles. One oxygen atom remains in combination with the two hydrogens (water), the liberated oxygen atom is very active and destroys bacteria. The amateur can have fair results in preparing hydrogen peroxide by treating barium dioxide with dilute sulphuric acid. A dilute acid composed of three parts of water to one part of acid is added to the manganese dioxide. The milky liquid is then filtered and collected in a flask as shown in the photo.

### Simple Hydrogen Sulphide Generator Is an Aid to Amateur Chemists

INEXPENSIVE apparatus for the generation of hydrogen sulphide in the home laboratory can be constructed in short order by duplicating the arrangement shown in the diagram. On a small scale, this setup will serve the purposes of a Kipp generator, and should provide enough hydrogen sulphide to fill all the needs of the amateur delver in analytical chemistry.

The apparatus consists principally of a 125-ml. distilling flask and a 3" funnel with a long stem. As in the drawing, the stem of the funnel is fitted through two stoppers in the neck of the flask, the lower stopper having a central hole and also two auxiliary holes through which acid passes as it rises from the bulb of the flask. On top of this stopper, around the stem of the funnel, are placed small lumps of ferrous sulphide. The distilling arm of the flask is extended by a stopcock fitted between rubber tubing further extended by a glass tube.

Warm hydrochloric acid is then poured down the funnel until it rises in the flask sufficiently to pass through the three-holed stopper and reach the sulphide. Gas from the reaction will pass the open stopcock and bubble through the solution to be tested. When the stopcock is closed, gas pressure will keep the acid from rising, and stop the action until the cock is reopened.—RICHARD BECK.

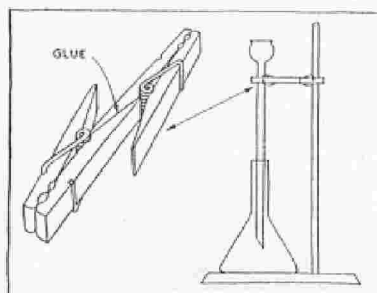
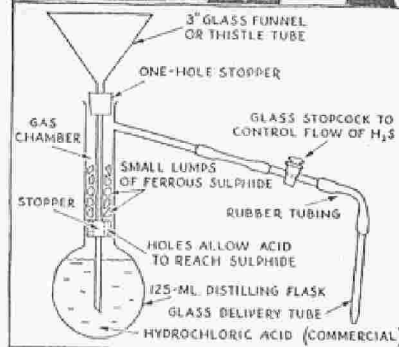

### Two Clothespins Form a Lab Clamp

GLUING two spring clothespins together, as indicated in the drawing, will provide a clamp that will come in handy for many purposes in a laboratory, such as holding glass tubing, funnels, and thistle tubes. It will also do much to reduce the breakage of fragile parts. The pins should be joined with a good grade of waterproof glue. If a C-clamp is not available, a third pin can be used to hold the legs of the other two pins together under pressure as the glue dries. When properly joined, homemade clamps of this kind will last a long time and prove themselves to be highly useful.—ANDREW LEE PECKEM, JR.

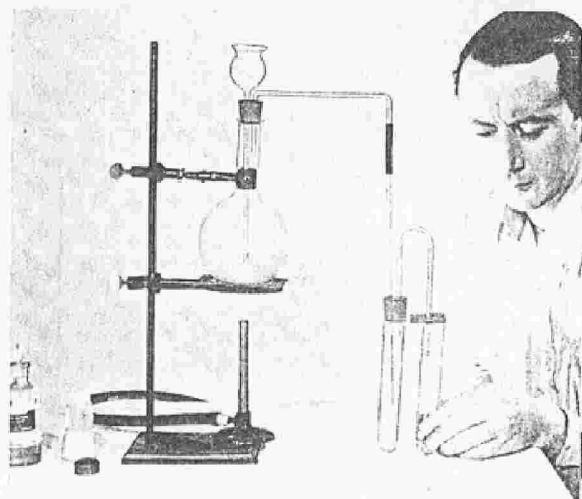

Generating hydrogen chloride gas by gently heating a mixture of salt and sulphuric acid. Bubbling through water in the test tube, the gas produces hydrochloric acid. What remains of the salt is crude sodium sulphate, or "salt cake"

In addition to making other sodium compounds from common salt, you can reverse the process and make sodium chloride from washing soda [sodium carbonate]. Saturate the soda with hydrochloric acid and then allow the acid to evaporate

HOME TESTS WITH  
COMMON SALT  
INTRODUCE VALUABLE  
SODIUM FAMILY



POPULAR SCIENCE NOVEMBER, 1944

**D**ID you know that by passing a current of electricity through a saturated solution of common table salt in water, you could change this vital food element into deadly biting lye; that by heating it with sulphuric acid, and leading the acrid gas evolved through water, you could make your own hydrochloric acid; and that by other chemical manipulations, mostly simple, you could transform salt into washing soda, baking soda, borax, Glauber's salt, and a long list of other valuable sodium compounds?

This is one of the fascinating features of chemistry—that compounds within a single chemical family, no matter how different in individual appearance and reaction, are intimately related, and that with the right magic touch from the chemist they may be changed endlessly from one to the other and back again.

In the case of salt and sodium compounds,

the possibility of transformation is fortunate. Salt, or sodium chloride, is one of the most abundant compounds in nature. Beds of rock salt are frequent. In the seas of the earth, alone, experts estimate that there are 36 million billion tons of salt. Salt is obtained from this source by running sea water into shallow basins and allowing it to evaporate.

Besides being an important mineral food, a preservative for meat and fish, and an element in freezing mixtures, common salt is the starting point for the manufacture of practically all sodium and chlorine compounds used today. Many of these manufacturing processes may be duplicated easily, on a small scale, in the home laboratory.

With only a glass U tube and a battery of several dry cells, for instance, you can demonstrate how a strong salt solution may be changed to a solution of sodium hydrox-



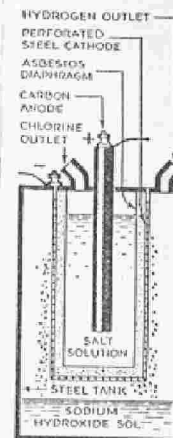
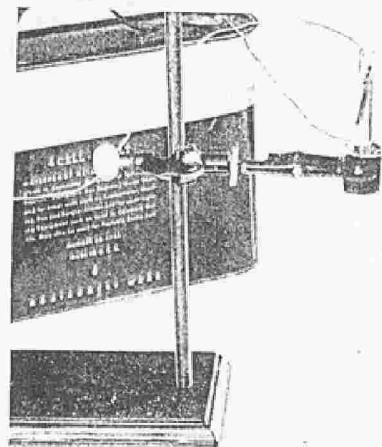

ide, known popularly as caustic soda or lye. Set up the tube as shown in the photograph, connecting the battery terminals to the brine through electrodes made of several magazine-pencil "leads" bound together. If you now place a few drops of red litmus solution in each branch of the tube, you can trace more readily what happens.

As soon as the battery wires are connected, the solution about the anode, or electrode connected to the positive pole of the battery, will begin to turn blue. This indicates the formation of sodium hydroxide, which is a strong alkali. At the same time, the solution about the other electrode, or cathode, will bleach out, owing to the formation of chlorine gas at that pole. Continued application of the current will finally change the salt completely to hydroxide.

Commercial production of this chemical is carried out by means of a Vorce or Nelson cell, an apparatus illustrated by the diagram. In this cell, the sodium hydroxide, the chlorine, and the hydrogen which is liberated at the anode, are kept separate to prevent complicated reactions. The gases are also collected for other industrial uses.

In many chemical changes, this is true: by-products are formed which are often as valuable as the chief chemical desired. When we mix salt with sulphuric acid, for example, and gently heat the

Experimental set-up for extracting chlorine, hydrogen, and sodium hydroxide (lye) from brine. Drawing shows the Nelson cell used commercially

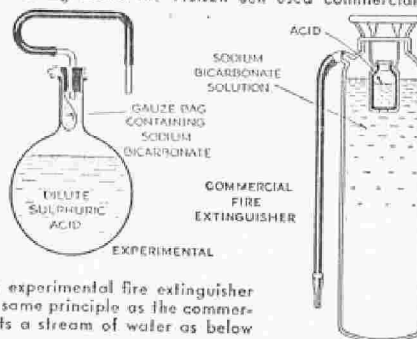

You can make an experimental fire extinguisher that works on the same principle as the commercial type. It squirts a stream of water as below



mixture, the gas hydrogen chloride is given off. Bubble this gas through plain water and we produce hydrochloric acid. What remains of the salt, after all the gas has been given up, and the remaining sulphuric acid evaporated, is no longer plain salt, but sodium sulphate. In its crude form this chemical is known as "salt cake," and when recrystallized and refined, as Glauber's salt, a cathartic.

The set-up for generating hydrogen chloride gas, making hydrochloric acid, and leaving sodium sulphate as a by-product, is clearly shown. Put the salt in the flask, and drop the sulphuric acid slowly through the thistle tube. To prevent too vigorous a reaction, use a very mild heat.

Next to salt itself, sodium carbonate is one of the most valuable sodium compounds. It is used in making glass, soap, and soap powders, and in refining petroleum; for softening water, cleaning and dyeing, and as a basis for other sodium compounds. It is found to only a limited extent in nature, but is manufactured in enormous quantities by a process invented by a Belgian chemist, Solvay.

One of the world's greatest chemical processes, the Solvay process is an amazing instance of complex chemical transformation in which nearly a dozen by-products are completely utilized. Its essence is this: carbon dioxide under pressure is forced through a saturated water solution of salt and ammonia gas. A number of complex reactions take place, producing finally a nearly insoluble sodium bicarbonate in a solution of ammonium chloride. The bicarbonate is separated from the solution by filtering, purified by washing, and changed to carbonate by heating.

The outstanding characteristic of sodium bicarbonate, known commonly as "baking soda," is its ability to liberate carbon dioxide when mixed with acid substances. Mixed with sour milk, or with powdered acids in baking powder, it generates gas that "raises" cake and bread dough. Mixed with sulphuric acid, it produces the pressure in chemical fire extinguishers.

In commercial fire extinguishers, a tank nearly filled with sodium bicarbonate solution has at its top a bottle of sulphuric acid. The bottle is so arranged that it will spill its contents, mixing them with the bicarbonate, when the tank is inverted.

An experimental extinguisher may be

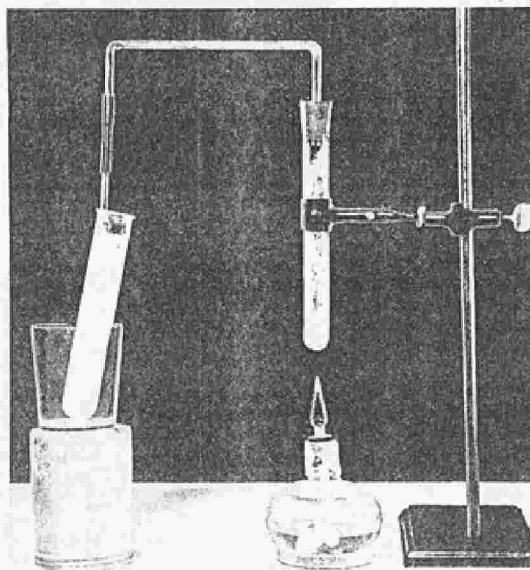

Sodium bicarbonate (baking soda) is changed into sodium carbonate by heating it. That the gas driven off is carbon dioxide is proved by its turning limewater cloudy

made from a flask and several pieces of tubing, as shown. To simplify construction, the solution in this case is dilute sulphuric acid, while the bicarbonate is placed in a small bag suspended above the solution when the flask is upright. By inverting the flask the chemicals mix, gas is formed, and the solution is forced out in a powerful stream.

Bicarbonate of soda is changed into sodium carbonate merely by heating it. Put a little in a test tube having a bent glass tube leading from it into a second test tube containing limewater. Apply heat to the first tube and bubbles of gas will come up through the limewater. They turn it milky, proving that the gas is carbon dioxide. When the gas stops bubbling, your baking soda has been changed into "soda ash," a dry form of sodium carbonate. Dissolve this dry powder in water, let the water evaporate slowly, and you finally find large crystals of "washing soda," sodium carbonate incorporating water in its structure.

Maybe you would now like to start reversing things! Dissolve sodium carbonate in water, and bubble carbon dioxide through it, and you change it to bicarbonate. Dissolve sodium carbonate in hydrochloric acid, let the acid evaporate, and you are back where you started, with common salt!



The drawing at the left illustrates an experiment for producing vacuum by rusting iron. Center, a solution of hypo becomes milky when cigarette smoke is blown upon it. Sal ammoniac will produce a very gentle, pretty snowstorm if the directions given in Mr. Wailes' article are followed.

## FASCINATING EXPERIMENTS in CHEMISTRY

by RAYMOND B. WAILES

**M**OST of the chemicals mentioned in these little experiments can be had at the corner drug store. By performing them many of the fundamental relationships of one kind of matter toward another can be gained.

It is commonly thought that only a flame or a red hot body can cause a substance to burn.



This shows how to make a fire without much heat. Ant powder, carbon bisulphide, will ignite from the heat of a curling iron held close.

phide, which is used to rid ants from lawns, and to keep them out of museum cases, will take fire at 250 C, which is about twice as hot as boiling water. A hot rod held over the substance will cause it to take fire.

When iron rusts, it combines with the oxygen of the air. An olive bottle containing steel wool or other ferrous substance, when inverted in a bottle of water, will soon have a partial vacuum inside it due to the combination of the oxygen in the water with the iron.

It all depends upon the kindling point, as one can determine for himself. Carbon bisul-

phide, One would believe that lampblack or charcoal could not be separated from sand, but this feat is easily done. Water wets sand very readily, but the air which is adsorbed (not absorbed) or encompassed by the charcoal causes the water to be shed as though the stuff were greased. Sieve the mixture of sand and lampblack through a screen into water. The sand will at once sink to the bottom. The charcoal will float away on the surface. This process is used a lot in recovery of carbonaceous by-products. Ores are sometimes finely pulverized and the metal in them reclaimed in this manner. The process is the same as ore flotation.

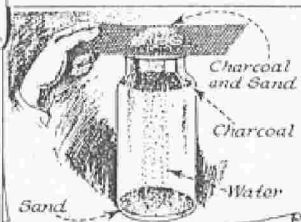

This shows an experiment comparable to modern filtration of dry solids. Charcoal and sand can easily be separated by adsorption of air as text explains.

Tincture of iodine heated in a test tube soon loses the alcohol which keeps it in solution. If a drop of mercury is now added and the heating continued, the mercury will unite with the iodine with a vivid flash of light.

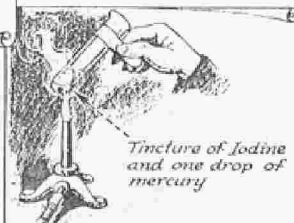

By driving off alcohol from iodine by evaporation, mercury and iodine will combine with a vivid flash.

# SIMPLE CHEMICAL EXPERIMENTS

## ILLUSTRATE INDUSTRIAL PROCESSES

*Mechanix Illustrated* December, 1943



To make alcohol, boil some mashed corn or potato for several minutes to extract starch. Change starch to sugar by adding dilute sulphuric acid and heating solution for ten minutes longer. When cool, add yeast cake and let stand for several days. Yeast changes sugar to alcohol by a very mysterious process, liberating carbon dioxide which causes foam (right).

ALCOHOL from potatoes, corn and surplus grain; bromine from the sea; sweet-smelling flavors from alcohol and acid; formaldehyde from wood alcohol,—these are just a few of the amazing transformations being accomplished by our modern chemists. With only a few test tubes, an alcohol lamp or Bunsen burner, and several simple chemicals, you can demonstrate the fundamentals of these processes in your home.

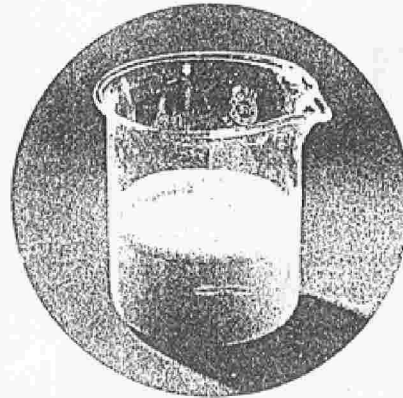

Dissolve some potassium dichromate in water and add a few drops of sulphuric acid and some of the fermented solution. Change of color from orange to light green is proof that alcohol is present (above).

Bromine is used in making tetraethyl lead. To show how chlorine separates it from sea water, add chlorine water to weak potassium bromide solution (below). Brown color indicates the presence of free bromine.



Next add a little carbon tetrachloride to this bromine solution and shake thoroughly. Free bromine will be dissolved in the carbon tetrachloride which will concentrate it into a dark brown solution and separate it from the water solution as shown in photo (right).



You can make oil of wintergreen by adding some sulphuric acid to  $\frac{1}{2}$ " of wood alcohol in a test tube and shaking up a powdered aspirin tablet in the mixture (above). Stopper tube tightly with cotton plug and let stand in warm water for fifteen minutes. Upon smelling the tube you will notice odor of wintergreen (right).



Formaldehyde can be obtained by heating a coil of copper wire to red heat and plunging it into the vapor of warm wood alcohol. Strong pungent odor of formaldehyde will be evident. Copper wire is a catalyst.

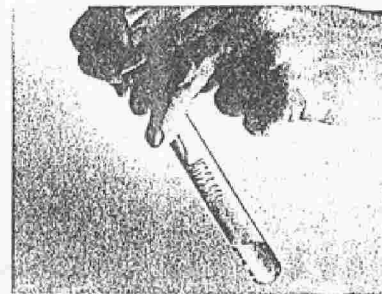

## INDEX

- Acid Burn Remedy.....164  
 Air Pistol.....28  
 Air Rifle Grip.....421  
 Best King Ever.....20  
 Blow Gun.....77  
 Bomb Disposal Guide.....317  
 Bomb Hitler Game.....75  
 Bunsen Burner.....191  
 Cannon, Electric.....30  
 Cannon, Model.....422  
 Cannon, Steam.....416  
 Chemical Stunts.....187  
 Chemical Tricks.....414  
 Chemistry Experiments..461,462  
 Clarence Stories.....95  
 Condenser.....444  
 Crazy World.....33  
 Crime Almanac.....100  
 Crime, increase.....164  
 Criminal's descendants.....164  
 Crossbow, Modern.....8  
 Crossbow, Repeating.....1  
 Crossbow, Notes.....4  
 Debunking Debunkers.....81  
 Detective, Army Course.....224  
 Feather Trimmer.....12  
 Fire Hazards, Chemical.....434  
 Fire Starters.....90  
 Fourth of July Display.....199  
 Grenade, German.....50  
 Gun, Siege, Model.....417  
 Guns Not To Buy.....312  
 Gun Tools.....13  
 Gym, Outdoor.....56  
 Gyroscope.....69  
 Hul Che.....67  
 Hydrogen Experiments.....455  
 Hydrogen Generator.....436  
 Hydrogen Sulphide generator457  
 Hydrometer, Salt.....436  
 Interrogation Course.....200  
 Ju Jitsu, Super.....119  
 Kevlar Frag Vest.....25  
 Kill, When To.....164  
 Knife, Hunting.....43  
 Lab Clamp.....457  
 Lab Stills.....449  
 Leather From Human Skin.....17  
 Line Of Sight.....118  
 Load Your Own.....57  
 Magic Garden.....445  
 M 1 Garand.....165  
 Machinegun, Air-Powered.....79  
 Match Rocket.....114  
 Mercury Fulminate.....33  
 Metal Casting.....401  
 Metal Plating Kit.....148  
 Metals, Chemistry Of.....497  
 Metals, Experiments.....454  
 Mortar, Carbide.....415  
 Negro Insurrections.....16  
 Peroxide Raises Bread.....436  
 Pistol, Electric.....34  
 Pistol, Pneumatic.....430  
 Poisoners.....65  
 Prison Camp Ingenuity.....21  
 Quartz Solution.....114  
 Rifle, Light Beam.....148  
 Rifle Rest.....17  
 Roman G.I.....35  
 Salt, Tests With.....458  
 Scalped On The Plains.....65  
 Senses, Untrustworthy.....453  
 Shooting, Hip.....86  
 Shooting, Practice.....91  
 Shotgun, Pipe.....31  
 Sight, Peep.....181  
 Silencers.....60  
 Sky Lanterns.....118  
 Sling.....80  
 Slingshot Sight.....49  
 Soldering Block.....34  
 Soldering Metal Sheets.....133  
 Soldiers, Shoot Straight...46  
 Southern Chivalry.....47  
 Specific Gravity, Finding..438  
 Squibs.....51  
 Stove, Crankcase Oil.....444  
 Stunts.....187  
 Table-Top Factories.....439  
 Target.....29  
 Targets, Can Covers.....432  
 Targets, Throwing.....425  
 Toy, Bean Gun.....426  
   Bombs Away.....427  
   Cannon.....80  
   Catapult.....133  
   Clothespin Slingshot..100  
   Landing Barge.....435  
   Parachute Proegctile...29  
   Rubber Band gun.....  
     .....66,76,223,429  
   Slingsnot.....421  
   Spool Gun.....421  
   Submachinegun.....53  
   Submarine.....400  
   Tank.....423  
   Trapshooter.....437  
 Unscrupulous Book Dealers...18  
 Volcano.....29,33